

**Mini-Mac
Applicator**

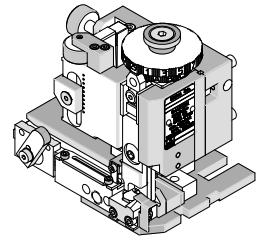

**Application Tooling
Specification Sheet**



Order No. 63892-6000

FEATURES

- Directly adapts to most automatic wire processing machines
- Applicator designed to industry standard mounting and shut height 135.80mm (5.346")
- Quick set-up time; plus the crimp height, track and feed adjustments can be set without removing the applicator from the press
- Fine adjustment allows users to achieve target with little effort by adjusting in increments of .015mm (.0006") for conductor crimp height and .063mm (.0025") for insulation height
- Independent adjustment rings allow users to quickly adjust the conductor or insulation crimp height without affecting each other.

SCOPE

Products: RAST5 High Normal Force (HNF) Female Terminals, 16-20 AWG.

Terminal Series No.	Terminal Order No.		Wire Size		Insulation Diameter		Strip Length	
			AWG	mm ²	mm	In.	mm	In.
94518	94518-0100	94518-0109	18-20	1.00-0.50	2.20-2.80	.087-.110.	5.00-5.50	.197-.216
	94518-0101	94518-0120						
	94518-0107	94518-0121						
	94518-0108							
94549	94549-0100	94549-0101	16-20	1.50-0.50	3.20 Max	.126 Max	5.00-5.50	.197-.216

DEFINITION OF TERMS

The following illustration is a generic terminal representation and not an exact image of any terminal listed in the scope.

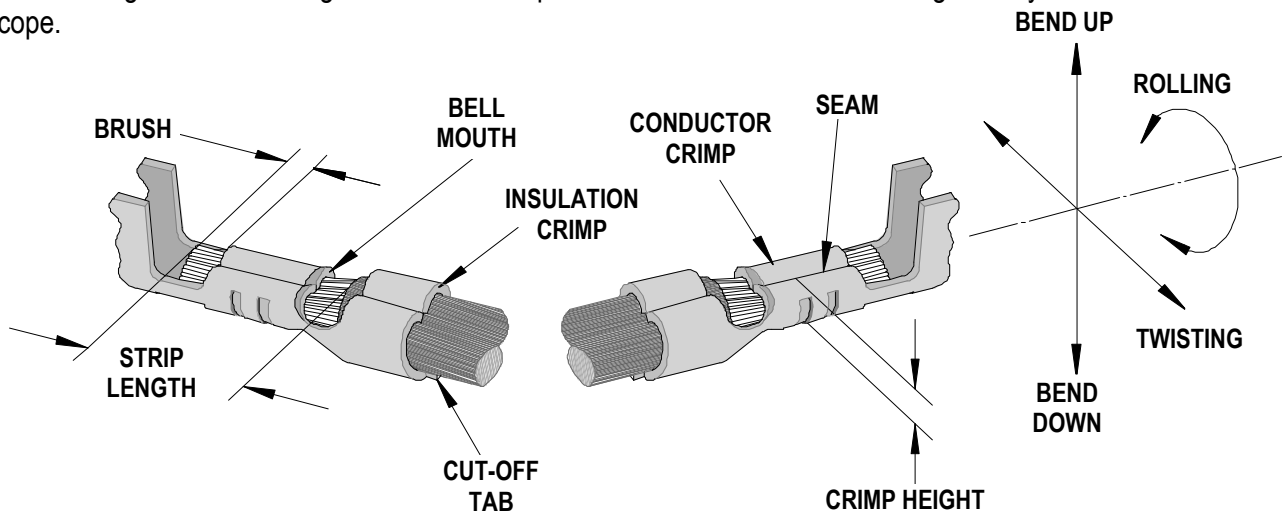

CRIMP SPECIFICATION

Terminal Series No.	Bell mouth		Cut-off Tab Max.		Conductor Brush	
	mm	In.	mm	In.	mm	In.
94518	0.20-0.40	.008-.016	0.60	.024	0.50-1.50	.020-.059
94549	0.20-.040	.008-.016	0.60	.024	0.50-1.50	.020-.059

Terminal Series No.	Bend up Bend down		Twist Roll		Punch Width (Ref)				Seam Seam shall not be open and no wire allowed out of the crimping area.
	Degree		Degree		Conductor		Insulation		
	mm	In	mm	In	mm	In	mm	In	
94518	3	3	4	8	2.15	.085	3.50	.138	
94549	3	3	4	8	2.15	.085	3.50	.138	

After crimping, the crimp profiles should measure the following:

Terminal Series No.	Wire Size		Crimp Height				Crimp Width (Ref.)				Pull Force Minimum	
			Conductor		Insulation (Ref.)		Conductor (Ref.)		Insulation (Ref.)			
	AWG	mm ²	mm	In.	mm	In.	mm	In.	mm	In.	N	Lb.
94518	18	0.75	1.50-1.57	.059-.062	3.00-3.10	.118-.122	2.20-2.30	.087-.091	3.60-3.70	.142-.146	117.7	26.5
	20	0.50	1.45-1.50	.057-.059	2.90-3.00	.114-.118	2.20-2.30	.087-.091	3.60-3.70	.142-.146	78.2	17.6
	-	1.00	1.57-1.67	.062-.066	3.10-3.20	.122-.126	2.20-2.30	.087-.091	3.60-3.70	.142-.146	157.0	35.3
94549	16	1.50	1.45-1.55	.057-.061	3.15-3.25	.124-.128	2.20-2.30	.087-.091	3.60-3.70	.142-.146	166.6	37.5
	18	0.75	1.35-1.45	.053-.057	3.05-3.15	.120-.124	2.20-2.30	.087-.091	3.60-3.70	.142-.146	107.8	24.3
	20	0.50	1.30-1.40	.051-.055	3.00-3.10	.118-.122	2.20-2.30	.087-.091	3.60-3.70	.142-.146	68.6	15.4
	-	1.00	1.40-1.50	.055-.059	3.10-3.20	.122-.126	2.20-2.30	.087-.091	3.60-3.70	.142-.146	147.0	33.1
	20 (2)	.50 (2)	1.40-1.50	.055-.059	3.45-3.55	.136-.140	2.20-2.30	.087-.091	3.60-3.70	.142-.146	68.6	15.4

Pull Force should be measured with no influence from the insulation crimp.
The above specifications are guidelines to an optimum crimp.

PARTS LIST

Mini-Mac Applicator 63892-6000				
Item	Order No	Engineering No.	Description	Quantity
Perishable Tooling				
	63892-6070	63892-6070	Tool Kit (All "Y" Items)	REF
1	63470-0001	63470-0001	Conductor Punch	1 Y
2	63832-0102	63832-0102	Conductor Anvil	1 Y
3	63471-0001	63471-0001	Insulation Punch	1 Y
4	63832-0104	63832-0104	Insulation Anvil	1 Y
5	63443-0035	63443-0035	Front Cut-off Plunger	1 Y
6	63443-0036	63443-0036	Front Cut-off Plunger Retainer	1 Y
Other Components				
7	11-18-4083	60707-8	Feed Cover	1
8	63443-0009	63443-0009	Scrap Chute Front	1
9	63443-0025	63443-0025	Key Dual Carrier	1
10	63443-0062	63443-0062	Collar-8.0mm Long	1
11	63443-0090	63443-0090	Wire Stop	1
12	63443-1700	63443-1700	Z Spacer	1
13	63443-2214	63443-2214	14.0mm Spacer	1
14	63443-2310	63443-2310	3.50mm Spacer	1
15	63443-6123	63443-6123	Rear Cover	1
16	63700-0539	63700-0539	Cut-Off Plunger Spring	1
17	63830-3001	63830-3001	Front Plunger Striker	1
Frame				
18	63801-3201	63801-3201	Top	1
19	63801-3281	63801-3281	Base	1
20	63801-4650	63801-4650	Track	1
Hardware				
21	N/A	N/A	M3 by 6 Long FHCS	1**
22	N/A	N/A	M3 by 6 Long SHCS	2**
23	N/A	N/A	M4 by 6 Long SHCS	2**
24	N/A	N/A	M4 by 12 Long BHCS	2**
25	N/A	N/A	M4 by 50 Long SHCS	2**
26	N/A	N/A	M5 by 12 Long SHCS	1**
27	N/A	N/A	M8 by 20 Long BHCS	1**
** Available from an industrial supply company such as MSC (1-800-645-7270).				

Assembly Drawing

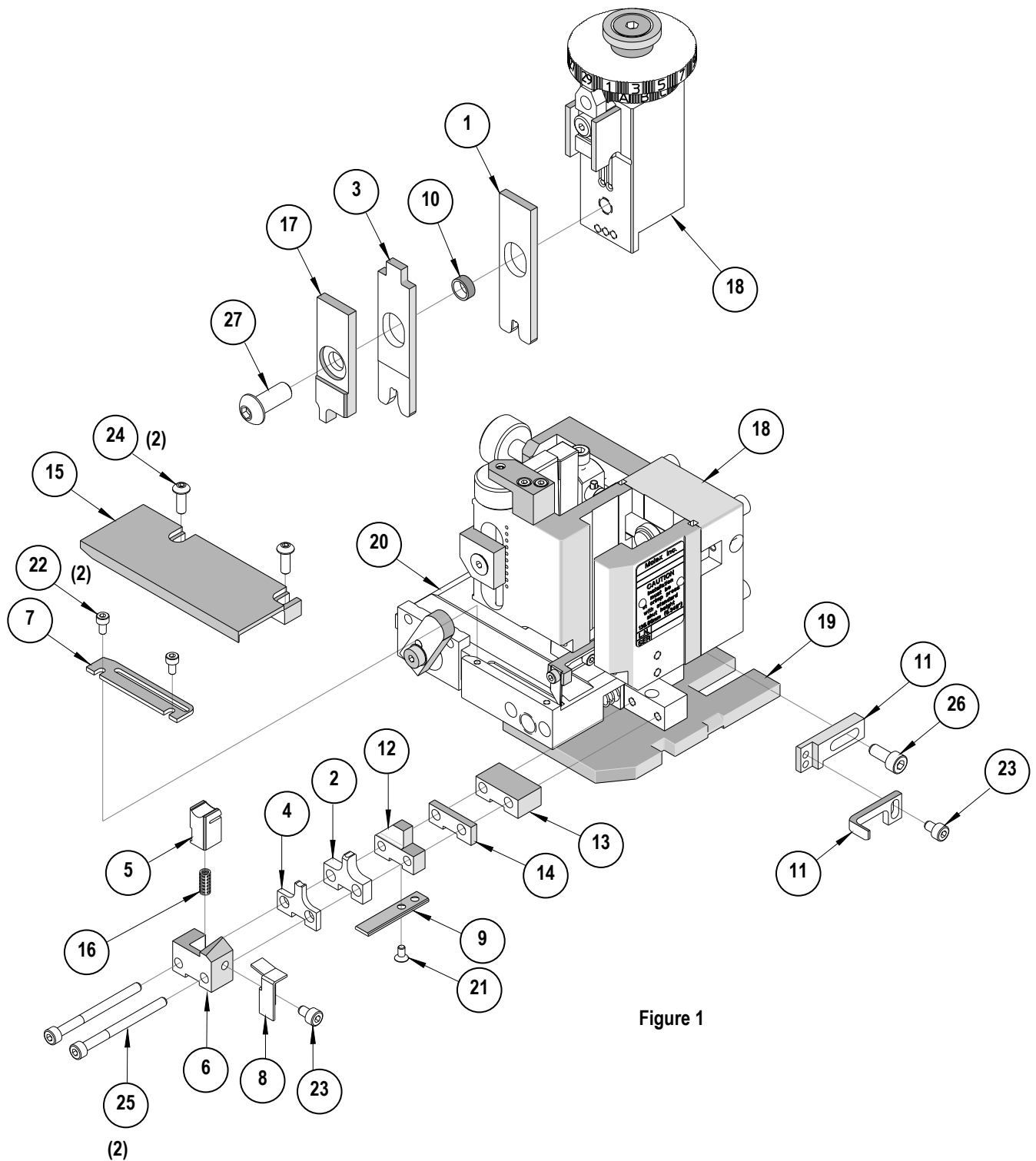

Figure 1

NOTES

1. Molex recommends an extra perishable tooling kit be maintained at your facility.
2. Verify tooling alignment by manually cycling the press and applicator before crimping under power. Check that all screws are tight.
3. Slugs, terminals, dirt, and oil should be kept clear of work area.
4. Wear safety glasses at all times.
5. For recommended maintenance refer to the Mini-Mac Manual.

CAUTION: This applicator should only be used in a press with a shut height of 135.80 mm (5.346"). Tooling damage could result at a lower setting

CAUTION: To prevent injury, never operate this applicator without the guards supplied with the press or wire-processing machine in place. Reference the press or wire processing manufacturer's instruction manual.

CAUTION: Molex crimp specifications are valid only when used with Molex terminals, applicators and tooling.

Contact Information

For more information on Molex application tooling please contact Molex at 1-800-786-6539.

<http://www.molex.com>



Компания «ЭлектроПласт» предлагает заключение долгосрочных отношений при поставках импортных электронных компонентов на взаимовыгодных условиях!

Наши преимущества:

- Оперативные поставки широкого спектра электронных компонентов отечественного и импортного производства напрямую от производителей и с крупнейших мировых складов;
- Поставка более 17-ти миллионов наименований электронных компонентов;
- Поставка сложных, дефицитных, либо снятых с производства позиций;
- Оперативные сроки поставки под заказ (от 5 рабочих дней);
- Экспресс доставка в любую точку России;
- Техническая поддержка проекта, помощь в подборе аналогов, поставка прототипов;
- Система менеджмента качества сертифицирована по Международному стандарту ISO 9001;
- Лицензия ФСБ на осуществление работ с использованием сведений, составляющих государственную тайну;
- Поставка специализированных компонентов (Xilinx, Altera, Analog Devices, Intersil, Interpoint, Microsemi, Aeroflex, Peregrine, Syfer, Eurofarad, Texas Instrument, Miteq, Cobham, E2V, MA-COM, Hittite, Mini-Circuits, General Dynamics и др.);

Помимо этого, одним из направлений компании «ЭлектроПласт» является направление «Источники питания». Мы предлагаем Вам помощь Конструкторского отдела:

- Подбор оптимального решения, техническое обоснование при выборе компонента;
- Подбор аналогов;
- Консультации по применению компонента;
- Поставка образцов и прототипов;
- Техническая поддержка проекта;
- Защита от снятия компонента с производства.



Как с нами связаться

Телефон: 8 (812) 309 58 32 (многоканальный)

Факс: 8 (812) 320-02-42

Электронная почта: org@eplast1.ru

Адрес: 198099, г. Санкт-Петербург, ул. Калинина, дом 2, корпус 4, литера А.