PRELIMINARY Product Specification

10Gb/s 10km XFP Optical Transceiver

FTLX1413M3BCL

PRODUCT FEATURES

- Supports 8.5Gb/s to 11.3Gb/s bit rates
- Power dissipation <1.5W
- Commercial temperature range: -5°C to 70°C
- RoHS-6 Compliant (lead-free)
- Hot-pluggable XFP footprint
- Single Power supply: 3.3V
- Maximum link length of 10km
- Uncooled 1310nm DFB laser
- No Reference Clock required
- Built-in digital diagnostic functions



APPLICATIONS

- SONET OC-192 SR-1
SDH STM I-64.1
- 10GBASE-LR/LW 10G Ethernet
- 1200-SM-LL-L 10G Fibre Channel
- 10GBASE-LR/LW with FEC
- 800-SM-LC-L 8.5G Fibre Channel

Finisar's FTLX1413M3BCL Small Form Factor 10Gb/s (XFP) transceivers are compliant with the current XFP Multi-Source Agreement (MSA) Specification¹. They comply with SONET OC-192 SR-1, SDH STM I-64.1, 10-Gigabit Ethernet 10GBASE-LR/LW per IEEE 802.3ae, 10G Fibre Channel 1200-SM-LL-L, and 8G Fibre Channel 800-SM-LC-L. Digital diagnostics functions are available via a 2-wire serial interface, as specified in the XFP MSA. The transceiver is RoHS compliant and lead free per Directive 2002/95/EC³, and Finisar Application Note AN-2038⁴.

PRODUCT SELECTION

FTLX1413M3BCL

I. Pin Descriptions

Pin	Logic	Symbol	Name/Description	Ref.
1		GND	Module Ground	1
2		VEE5	Optional –5.2 Power Supply – Not required	
3	LVTTL-I	Mod-Desel	Module De-select; When held low allows the module to respond to 2-wire serial interface commands	
4	LVTTL-O	Interrupt	Interrupt (bar); Indicates presence of an important condition which can be read over the serial 2-wire interface	2
5	LVTTL-I	TX_DIS	Transmitter Disable; Transmitter laser source turned off	
6		VCC5	+5 Power Supply– Not required	
7		GND	Module Ground	1
8		VCC3	+3.3V Power Supply	
9		VCC3	+3.3V Power Supply	
10	LVTTL-I	SCL	Serial 2-wire interface clock	2
11	LVTTL-I/O	SDA	Serial 2-wire interface data line	2
12	LVTTL-O	Mod_Abs	Module Absent; Indicates module is not present. Grounded in the module.	2
13	LVTTL-O	Mod_NR	Module Not Ready; Finisar defines it as a logical OR between RX_LOS and Loss of Lock in TX/RX.	2
14	LVTTL-O	RX_LOS	Receiver Loss of Signal indicator	2
15		GND	Module Ground	1
16		GND	Module Ground	1
17	CML-O	RD-	Receiver inverted data output	
18	CML-O	RD+	Receiver non-inverted data output	
19		GND	Module Ground	1
20		VCC2	+1.8V Power Supply – Not required	
21	LVTTL-I	P_Down/RST	Power Down; When high, places the module in the low power stand-by mode and on the falling edge of P_Down initiates a module reset Reset; The falling edge initiates a complete reset of the module including the 2-wire serial interface, equivalent to a power cycle.	
22		VCC2	+1.8V Power Supply – Not required	
23		GND	Module Ground	1
24	PECL-I	RefCLK+	Reference Clock non-inverted input, AC coupled on the host board – Not required	3
25	PECL-I	RefCLK-	Reference Clock inverted input, AC coupled on the host board – Not required	3
26		GND	Module Ground	1
27		GND	Module Ground	1
28	CML-I	TD-	Transmitter inverted data input	
29	CML-I	TD+	Transmitter non-inverted data input	
30		GND	Module Ground	1

Notes:

1. Module circuit ground is isolated from module chassis ground within the module.
2. Open collector; should be pulled up with 4.7k – 10kohms on host board to a voltage between 3.15V and 3.6V.
3. A Reference Clock input is not required by the FTLX1413M3BCL. If present, it will be ignored.

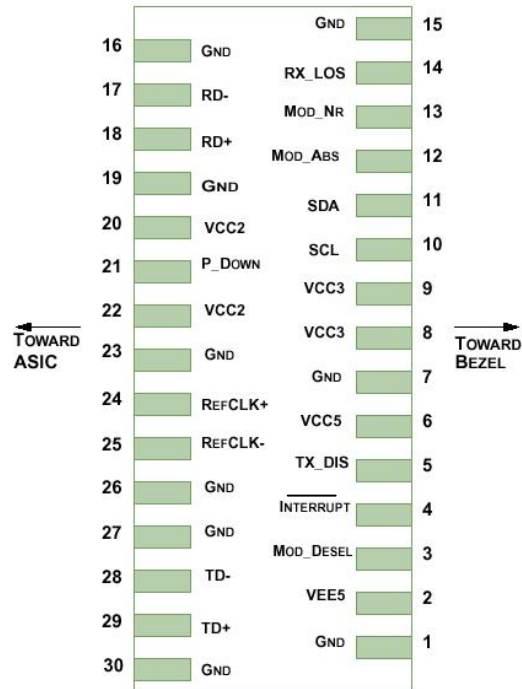

Diagram of Host Board Connector Block Pin Numbers and Name

II. Absolute Maximum Ratings

Parameter	Symbol	Min	Typ	Max	Unit	Ref.
Maximum Supply Voltage	V _{cc3}	-0.5		4.0	V	
Storage Temperature	T _S	-40		85	°C	
Case Operating Temperature	T _{OP}	-5		70	°C	

III. Electrical Characteristics ($T_{OP} = -5$ to 70 °C, $V_{CC3} = 3.13$ to 3.45 Volts)

Parameter	Symbol	Min	Typ	Max	Unit	Ref.	
Supply Voltage	V _{cc3}	3.13		3.45	V		
Supply Current	I _{cc3}			600	mA		
Module total power	P			1.5	W	1	
Transmitter							
Input differential impedance	R _{in}		100		Ω	2	
Differential data input swing	V _{in,pp}	120		820	mV	3	
Transmit Disable Voltage	V _D	2.0		V _{cc}	V	4	
Transmit Enable Voltage	V _{EN}	GND		GND+ 0.8	V		
Transmit Disable Assert Time				10	us		
Receiver							
Differential data output swing	V _{out,pp}	340	650	850	mV	5	
Data output rise time	t _r			38	ps	6	
Data output fall time	t _f			38	ps	6	
LOS Fault	V _{LOS fault}	V _{cc} – 0.5		V _{ccHOST}	V	7	
LOS Normal	V _{LOS norm}	GND		GND+0.5	V	7	
Power Supply Rejection	PSR	See Note 8 below					8

Notes:

1. Maximum total power value is specified across the full temperature and voltage range.
2. After internal AC coupling.
3. SONET/SDH jitter generation requirements are guaranteed with a minimum differential data input swing of 500mV peak-to-peak.
4. Or open circuit.
5. Into 100 ohms differential termination.
6. 20 – 80 %
7. Loss Of Signal is open collector to be pulled up with a 4.7k – 10kohm resistor to 3.15 – 3.6V. Logic 0 indicates normal operation; logic 1 indicates no signal detected.
8. Per Section 2.7.1. in the XFP MSA Specification¹.

IV. Optical Characteristics ($T_{OP} = -5$ to 70°C , $V_{CC3} = 3.13$ to 3.45 Volts)

Parameter	Symbol	Min	Typ	Max	Unit	Ref.
Transmitter						
Output Opt. Pwr: 9/125 SMF	P_{OUT}	-6		-1	dBm	1
Optical Wavelength	λ	1290		1330	nm	
Optical Extinction Ratio	ER	6			dB	1
Sidemode Supression ratio	SSR_{min}	30			dB	
Tx Jitter (SONET/SDH) 20kHz-80MHz	Tx_{j1}			0.3	UI	
Tx Jitter (SONET/SDH) 4MHz – 80MHz	Tx_{j2}			0.1	UI	
Relative Intensity Noise	RIN			-130	dB/Hz	
Receiver						
Receiver Sensitivity @ 10.5Gb/s	R_{SENS1}			-14.4	dBm	2
Receiver Sensitivity @ 11.3Gb/s	R_{SENS2}			-13.4	dBm	2
Stressed Receiver Sensitivity (OMA) @ 10.5Gb/s	R_{SENS3}			-10.3	dBm	3
Maximum Input Power	P_{MAX}	+0.5			dBm	
Optical Center Wavelength	λ_C	1270		1600	nm	
Receiver Reflectance	R_{rx}			-14	dB	
LOS De-Assert	LOS_D			-18	dBm	
LOS Assert	LOS_A	-32			dBm	
LOS Hysteresis		0.5			dB	

Notes:

1. Having ER = 6 dB guarantees that the -6 dBm minimum output power meets IEEE 802.3ae requirement of OMA=-5.2dBm.
2. Measured with worst ER; BER<10⁻¹²; 2³¹ – 1 PRBS. Complies with -12.6 dBm OMA at ER = 6 dB.
3. Per IEEE 802.3ae. Equivalent to -13.3 dBm average power at Infinite ER, -11.08 dBm at ER = 6 dB.

8.5Gb/s Fibre-Channel:

To operate the FTLX1413D3BCL at 8.5Gb/s Fibre-Channel, the EEPROM-Table 0, Byte TBD, Bit TBD must be set as follows; .

- EEPROM Byte TBD, Bit TBD value for 8GFC:
- EEPROM Byte TBD, Bit TBD value for 10Gb/s rates:
(If CDRs Bypassed → Byte 111, Bit 0)

By default, a power cycling the transceiver will return the transceiver to normal 10Gb/s operation

V. General Specifications

Parameter	Symbol	Min	Typ	Max	Units	Ref.
Bit Rate	BR	8.5		11.3	Gb/s	1
Bit Error Ratio	BER			10 ⁻¹²		2
Max. Supported Link Length	L _{MAX}		10		km	1

Notes:

- SONET OC-192 SR-1, SDH STM I-64.1, 10GBASE-LR/LW, 1200-SM-LL-L, 800-SM-LC-L, SONET OC-192 with FEC, 10GBASE-LR/LW + FEC, 1200-SM-LL-L + FEC.
- Tested with a 2³¹ – 1 PRBS

VI. Environmental Specifications

Finisar FTLX1413M3BCL transceivers have a commercial operating case temperature range of -5°C to +70°C.

Parameter	Symbol	Min	Typ	Max	Units	Ref.
Case Operating Temperature	T _{op}	-5		70	°C	
Storage Temperature	T _{sto}	-40		85	°C	

VII. Regulatory Compliance

Finisar XFP transceivers are Class 1 Laser Products. They are certified per the following standards:

Feature	Agency	Standard	Certificate Number
Laser Eye Safety	FDA/CDRH	CDRH 21 CFR 1040 and Laser Notice 50	TBD
Laser Eye Safety	TÜV	EN 60825-1: 2007, EN60825-2:2004+A1 IEC 60825-1: 2007 (2 nd Edition) IEC 60825-2: 2010 (3 rd Edition)	TBD
Electrical Safety	TÜV	EN 60950:2006+A11	TBD
Electrical Safety	UL/CSA	CLASS 3862.07 CLASS 3862.87	TBD

Copies of the referenced certificates are available at Finisar Corporation upon request.

VIII. Digital Diagnostic Functions

As defined by the XFP MSA¹, Finisar XFP transceivers provide digital diagnostic functions via a 2-wire serial interface, which allows real-time access to the following operating parameters:

- Transceiver temperature
- Laser bias current
- Transmitted optical power
- Received optical power
- Transceiver supply voltage

It also provides a sophisticated system of alarm and warning flags, which may be used to alert end-users when particular operating parameters are outside of a factory-set normal range.

The operating and diagnostics information is monitored and reported by a Digital Diagnostics Transceiver Controller (DDTC) inside the transceiver, which is accessed through the 2-wire serial interface. When the serial protocol is activated, the serial clock signal (SCL pin) is generated by the host. The positive edge clocks data into the XFP transceiver into those segments of its memory map that are not write-protected. The negative edge clocks data from the XFP transceiver. The serial data signal (SDA pin) is bi-directional for serial data transfer. The host uses SDA in conjunction with SCL to mark the start and end of serial protocol activation. The memories are organized as a series of 8-bit data words that can be addressed individually or sequentially. The 2-wire serial interface provides sequential or random access to the 8 bit parameters, addressed from 000h to the maximum address of the memory.

For more detailed information including memory map definitions, please see Finisar Application Note AN-2035 “Digital Diagnostic Monitoring Interface for XFP Optical Transceivers”, or the XFP MSA Specification¹.

IX. Mechanical Specifications

Finisar’s XFP transceivers are compliant with the dimensions defined by the XFP Multi-Sourcing Agreement (MSA).

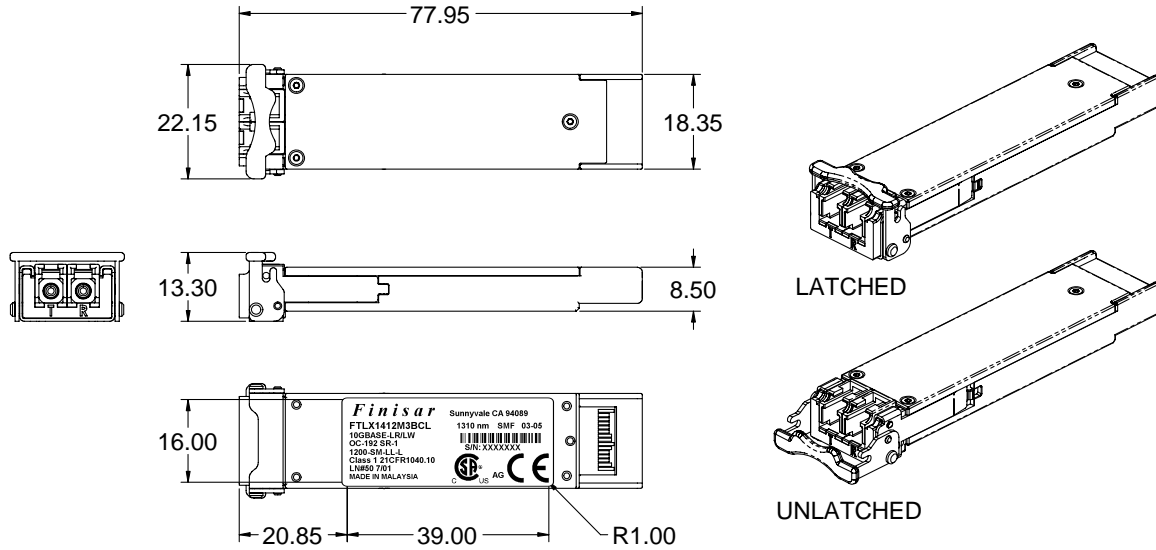

XFP Transceiver (dimensions are in mm)

X. PCB Layout and Bezel Recommendations

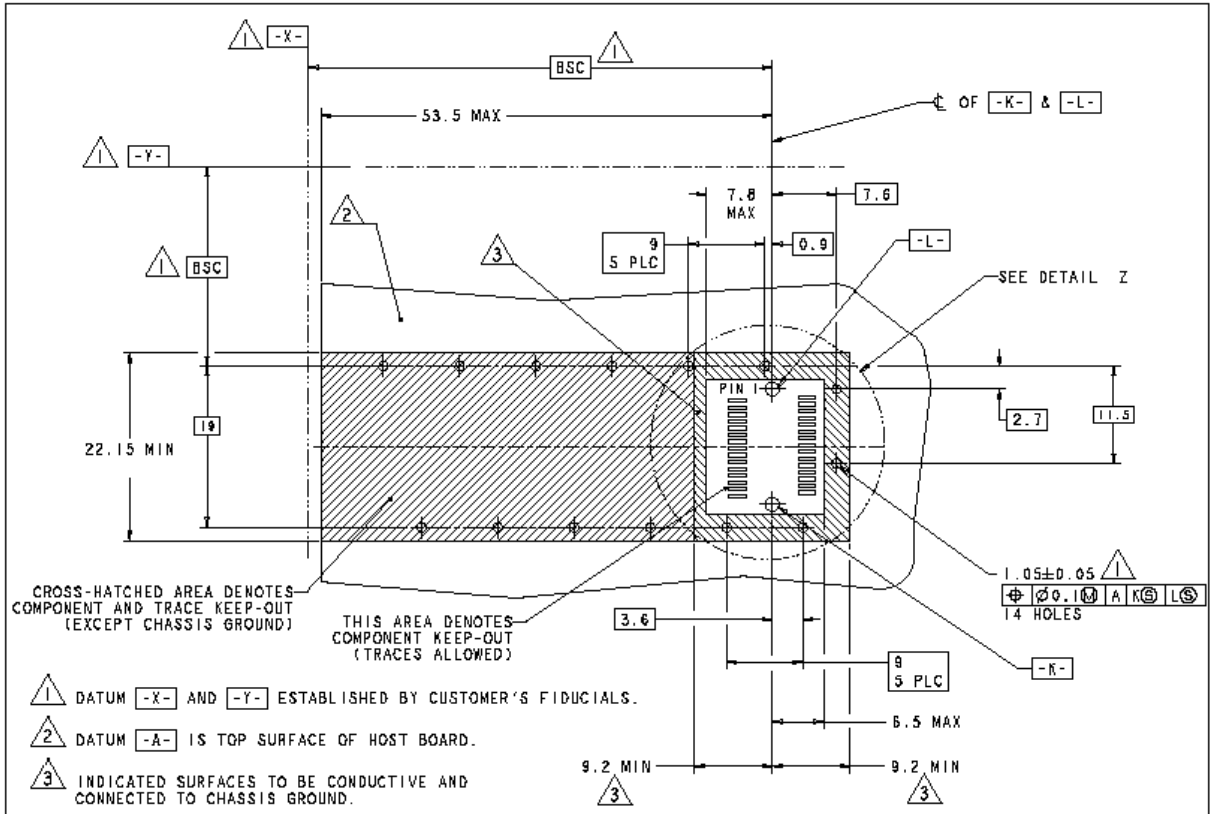

XFP Host Board Mechanical Layout (dimensions are in mm)

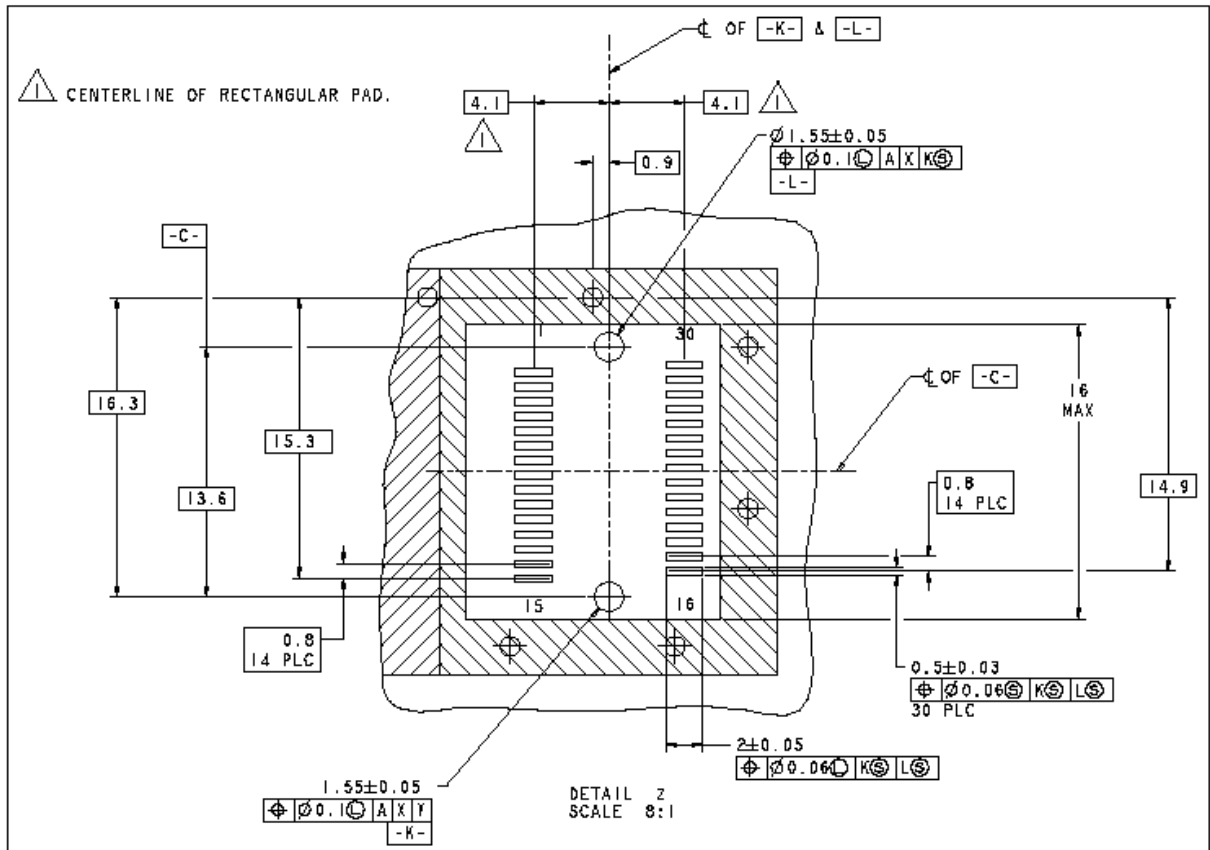

XFP Detail Host Board Mechanical Layout (dimensions are in mm)

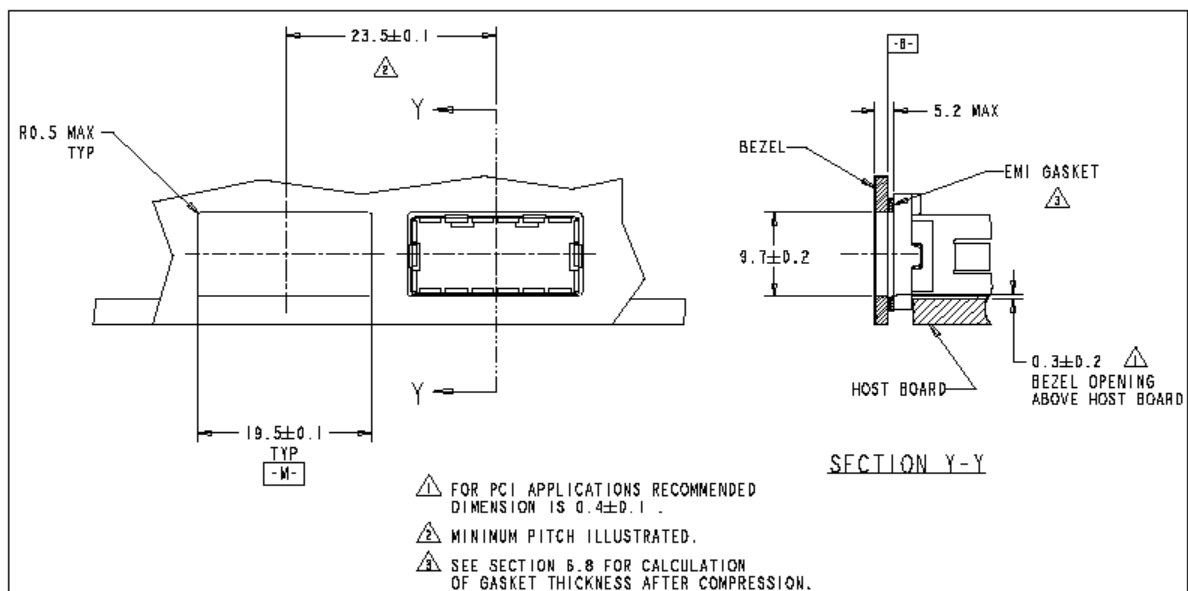

XFP Recommended Bezel Design (dimensions are in mm)

XI. References

1. 10 Gigabit Small Form Factor Pluggable Module (XFP) Multi-Source Agreement (MSA), Rev 4.5 – August 2005. Documentation is currently available at <http://www.xfpmsa.org/>
2. Application Note AN-2035: “Digital Diagnostic Monitoring Interface for XFP Optical Transceivers” – Finisar Corporation, December 2003
3. Directive 2002/95/EC of the European Council Parliament and of the Council, “on the restriction of the use of certain hazardous substances in electrical and electronic equipment”. January 27, 2003.
4. “Application Note AN-2038: Finisar Implementation Of RoHS Compliant Transceivers”, Finisar Corporation, January 21, 2005.

XII. Revision History

Revision	Date	Description
A1	3/1/2011	<ul style="list-style-type: none"> • Document created.

XIII. For More Information

Finisar Corporation
 1389 Moffett Park Drive
 Sunnyvale, CA 94089-1133
 Tel. 1-408-548-1000
 Fax 1-408-541-6138
sales@finisar.com
www.finisar.com



Компания «ЭлектроПласт» предлагает заключение долгосрочных отношений при поставках импортных электронных компонентов на взаимовыгодных условиях!

Наши преимущества:

- Оперативные поставки широкого спектра электронных компонентов отечественного и импортного производства напрямую от производителей и с крупнейших мировых складов;
- Поставка более 17-ти миллионов наименований электронных компонентов;
- Поставка сложных, дефицитных, либо снятых с производства позиций;
- Оперативные сроки поставки под заказ (от 5 рабочих дней);
- Экспресс доставка в любую точку России;
- Техническая поддержка проекта, помощь в подборе аналогов, поставка прототипов;
- Система менеджмента качества сертифицирована по Международному стандарту ISO 9001;
- Лицензия ФСБ на осуществление работ с использованием сведений, составляющих государственную тайну;
- Поставка специализированных компонентов (Xilinx, Altera, Analog Devices, Intersil, Interpoint, Microsemi, Aeroflex, Peregrine, Syfer, Eurofarad, Texas Instrument, Miteq, Cobham, E2V, MA-COM, Hittite, Mini-Circuits, General Dynamics и др.);

Помимо этого, одним из направлений компании «ЭлектроПласт» является направление «Источники питания». Мы предлагаем Вам помощь Конструкторского отдела:

- Подбор оптимального решения, техническое обоснование при выборе компонента;
- Подбор аналогов;
- Консультации по применению компонента;
- Поставка образцов и прототипов;
- Техническая поддержка проекта;
- Защита от снятия компонента с производства.



Как с нами связаться

Телефон: 8 (812) 309 58 32 (многоканальный)

Факс: 8 (812) 320-02-42

Электронная почта: org@eplast1.ru

Адрес: 198099, г. Санкт-Петербург, ул. Калинина, дом 2, корпус 4, литера А.