

LC75843UGAGEVB

LC75843UGA LCD Driver IC Evaluation Board User's Manual



ON Semiconductor®

<http://onsemi.com>

EVAL BOARD USER'S MANUAL

Overview

The LC75843UGAGEVB is an evaluation board for operation check of 1/1 to 1/4 duty general-purpose LCD driver IC (LC75843UGA). This evaluation board has a power supply circuit, a controller circuit, an LCD driver IC circuit, an LCD panel circuit, an LED circuit. Therefore, this evaluation board can facilitate the operation check (state setting and waveform monitor, etc.) of the LCD driver IC. In addition, this evaluation board can automatically demonstrate.

Features

- This Evaluation Board is Equipped with a Controller, and the Control of the LCD Driver IC is Possible by Serial Communication (CCB* Format)
- The 1/4 Duty LCD Panel is Implemented
- Capable of the LED Control by the General-purpose Port of the LCD Driver IC (Capable of the LED Brightness Adjustment by the PWM Control)

- Capable of Waveform Monitor of All Common Outputs, All Segment Outputs and All General-purpose Port Outputs
- This Evaluation Board can Separate the Signal between Each Circuit Block. Therefore the External Input to an LCD Driver IC is Possible
- This Evaluation Board has the Demonstration Mode which Automatically Performs LCD Display and LED Control by Controller Control
- This Evaluation Board is Pb-free and RoHS Compliant

*CCB® is ON Semiconductor's original format. All addresses are managed by ON Semiconductor for this format.

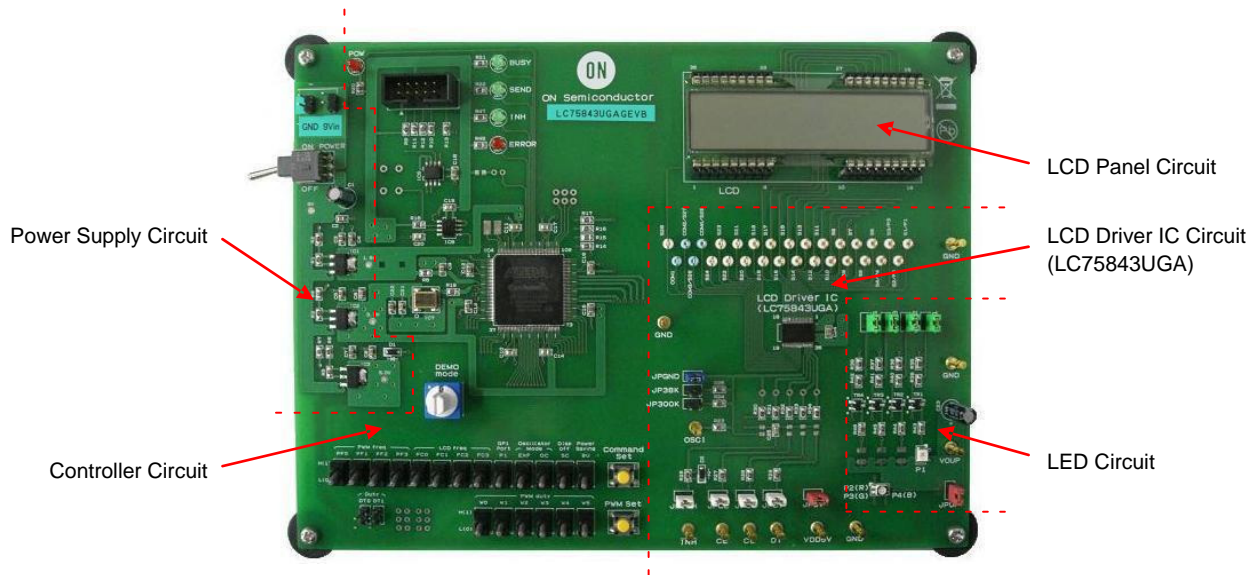

Figure 1. Appearance of LCD Driver IC Evaluation Board (LC75843UGAGEVB)

LC75843UGAGEVB

SPECIFICATIONS

Table 1. RECOMMENDED OPERATING CONDITIONS

Parameter	Symbol	Conditions	Value/Ratings			Unit
			Min	Typ	Max	
Specifications of LCD Driver IC Evaluation Board (LC75843UGAGEVB)						
Main Power Supply Voltage	9Vin		7.0	9.0	12.0	V
Pull-up Power Supply Voltage for LED	VOUP	When the jump socket of the JPUP is removed and an external power supply is inputted from VOUP pin.	4.5	5.0	6.3	V
Main Power Supply Current	IDD9V	9Vin = 9.0 V, When the switch of the P1 is set to H(1) and moving the "All ON test (DEMO mode = "1")" mode. (This condition is a maximum current flow)	–	125	–	mA
Board Size			200 mm × 150 mm, t = 1.6 mm			
Board Material			Glass Epoxy (FR4), 2-levels, Copper Foil 35 μm			

Specifications of LCD Driver IC (LC75843UGA)

Power Supply Voltage	V _{DD}	When the jump socket of the JP5V is removed and an external power supply is inputted from VDD5V pin.	4.5	–	6.3	V
Input High Level Voltage	V _{IH1}	When the jump sockets of the JPINH, JPCE, JPCL and JPDI are removed and an external signal is inputted from CE, CL, DI and IINH pins.	0.4 V _{DD}	–	6.3	V
	V _{IH2}	When the jump sockets of the JPGND, JP38K and JP300K are removed and an external clock is inputted from OSCI pin.	0.4 V _{DD}	–	6.3	V
Input Low Level Voltage	V _{IL1}	When the jump sockets of the JPINH, JPCE, JPCL and JPDI are removed and an external signal is inputted from CE, CL, DI and IINH pins.	0	–	0.2 V _{DD}	V
	V _{IL2}	When the jump sockets of the JPGND, JP38K and JP300K are removed and an external clock is inputted from OSCI pin.	0	–	0.2 V _{DD}	V
CCB Serial Clock Operating Frequency	f _{CL}	When the jump socket of the JPCL is removed and an external signal is inputted from CL pin.	–	–	3.125	MHz
External Clock Operating Frequency	f _{CK}	When the jump sockets of the JPGND, JP38K and JP300K are removed and an external clock is inputted from OSCI pin.	10	300	600	kHz
External Clock Duty Cycle	D _{CK}	When the jump sockets of the JPGND, JP38K and JP300K are removed and an external clock is inputted from OSCI pin.	30	50	70	%

Functional operation above the stresses listed in the Recommended Operating Ranges is not implied. Extended exposure to stresses beyond the Recommended Operating Ranges limits may affect device reliability.

NOTE: We have a case to change these specifications without a notice for improvement.

LC75843UGAGEVB

BLOCK DIAGRAM

The following figure shows the block diagram of the LC75843UGAGEVB.

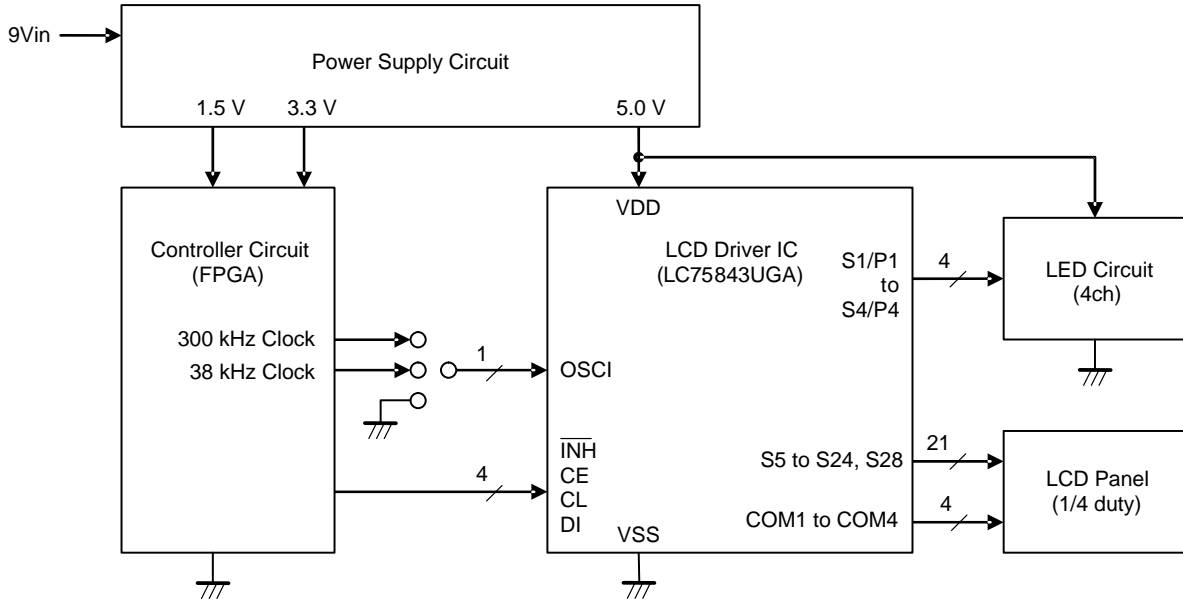

Figure 2. Block Diagram of LCD Driver IC Evaluation Board (LC75843UGAGEVB)

TEST PROCEDURE

When the All Circuits in the LC75843UGAGEVB Board Are Used

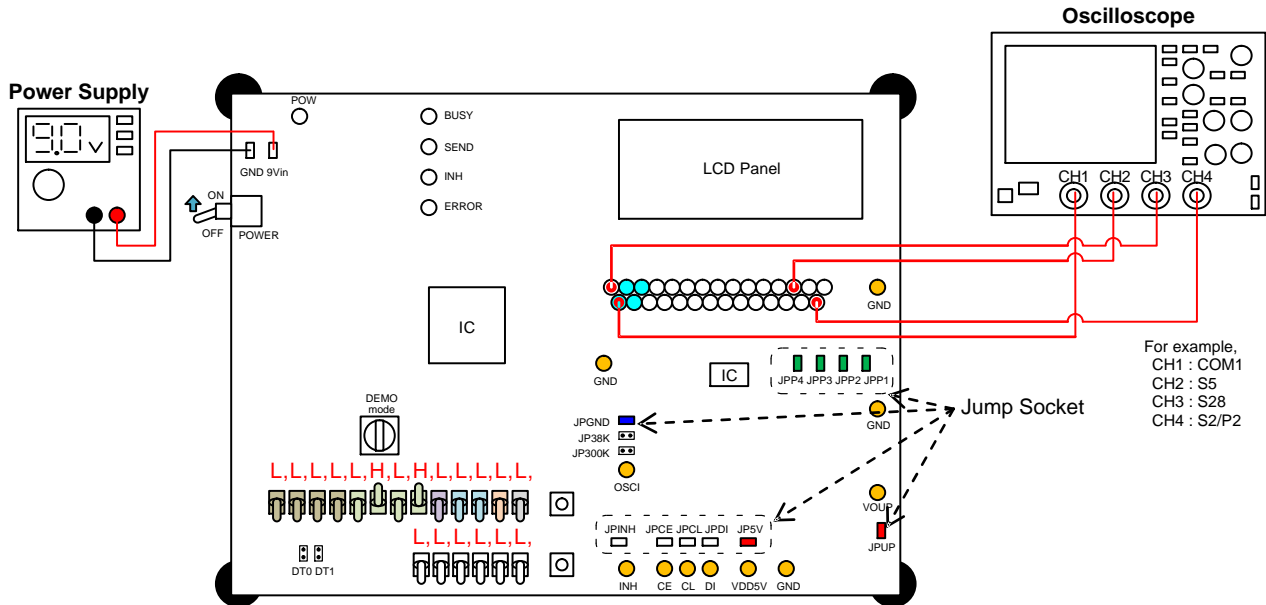

Figure 3. The Test Constitution when the All Circuits in the LC75843UGAGEVB Board Are Used

LC75843UGAGEVB

1. Connect the test setup as shown in Figure 3.
2. Insert the jump sockets of the JP5V, JPGND, JPINH, JPCE, JPCL, JPDI, JPUP, JPP1, JPP2, JPP3 and JPP4, and remove the jump sockets of the DT0, DT1, JP38K and JP300K.
3. The power supply of the evaluation board is turned on by moving “POWER” switch to the “ON” position. (The red LED monitor of the “POW” is turned on)
4. An automatic demonstration mode is selected by moving “DEMO mode” switch to the “9” position.
5. Set the following switches. About the setting contents details of the switch, refer to “Explanation of the Switches of Setting the Control Data”.

Switches	Functions	Contents Which Are Set
PF0 to PF3	PWM output waveform frame frequency select.	The PWM output waveform frame frequency is 195 [Hz] by moving “PF0, PF1, PF2, PF3” switch to the “L(0), L(0), L(0), L(0)” position.
FC0 to FC3	Common/Segment output waveform frame frequency select.	The common/segment output waveform frame frequency is 97 [Hz] by moving “FC0, FC1, FC2, FC3” switch to the “L(0), H(1), L(0), H(1)” position.
P1	General-purpose output port (S1/P1) function select.	L(0) : Low level output mode
EXF	External clock operating frequency mode select at OC = H(1).	L(0) : 300 kHz input operating mode
OC	Fundamental clock operating mode select.	L(0) : Internal oscillator clock operating mode
SC	Display on/off select.	L(0) : Normal display mode
BU	Power saving mode select.	L(0) : Normal mode
W0 to W5	PWM output waveform duty select.	When switch of the “DEMO mode” is set to “9”, duty of the PWM output waveform is automatically set, therefore switches of the “W0 to W5” are set to “L(0), L(0), L(0), L(0), L(0), L(0)” position.

6. The CCB serial data are transferred from a controller circuit to LCD driver IC by pushing the “Command Set” switch. (The green LED monitor of the “BUSY” and “INH” are turned on)
7. The customer can confirm the movement of the LCD display and LED brightness adjustment by the automatic demonstration. Then, the customer can confirm the waveform of the common outputs (COM1 to COM4), segment outputs (S5 to S24, S28) and general-purpose port outputs (P1 to P4).

- The customer can confirm that LEDs from P1 to P4 change brightly gradually.

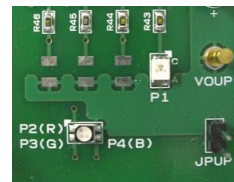

For example, when the DEMO mode is “9”

- The green LED monitor of the “SEND” flashes quickly.
- The customer can confirm that a “AUTO” characters and a PWM duty value are displayed to LCD.

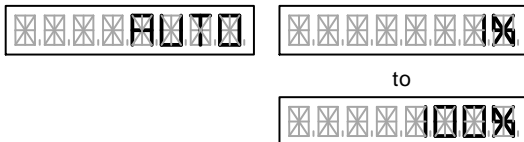

LC75843UGAGEVB

When the External Power Supply Is Used

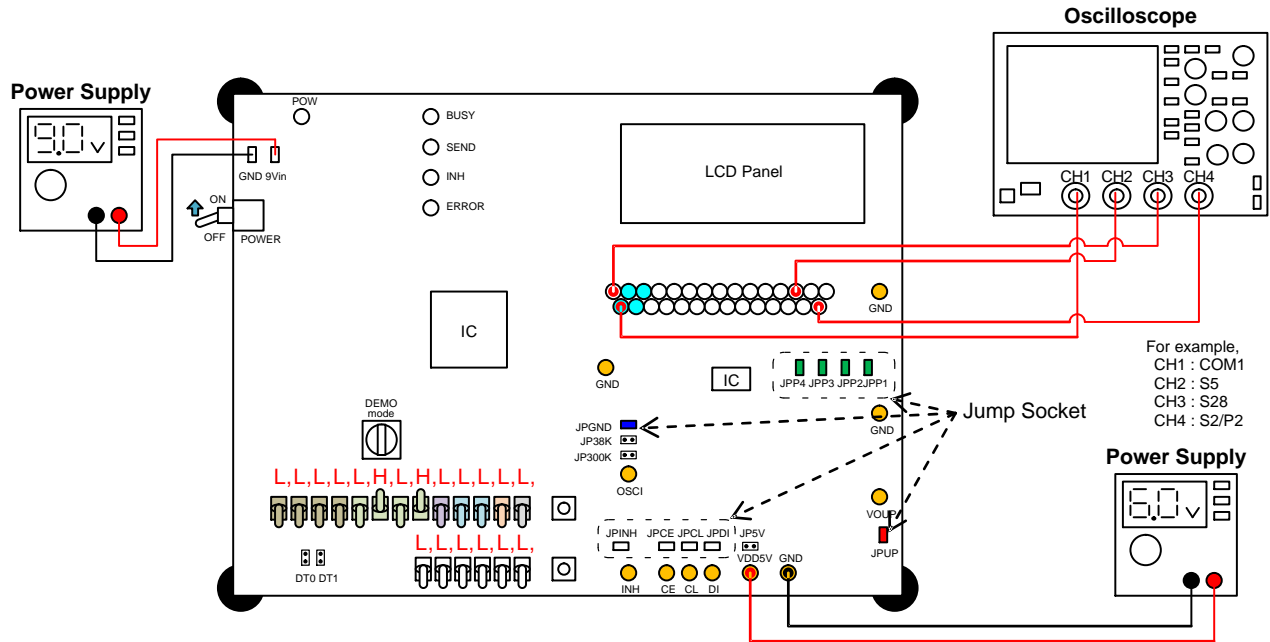

Figure 4. The Test Constitution when the External Power Supply Is Used

1. Connect the test setup as shown in Figure 4.
2. Insert the jump sockets of the JPGND, JPINH, JPCE, JPCL, JPDI, JPUP, JPP1, JPP2, JPP3 and JPP4, and remove the jump sockets of the DT0, DT1, JP38K, JP300K and JP5V.
3. The power supply of the evaluation board is turned on by moving “POWER” switch to the “ON” position. (The red LED monitor of the “POW” is turned on)
4. Supply the voltage of the external power supply to “VDD5V” pin. The following specification shows the allowable operating ranges of LC75843UGA.

Parameter	Symbol	Min	Typ	Max	Unit
Power Supply Voltage for LC75843UGA	V_{DD}	4.5	–	6.3	V

5. An automatic demonstration mode is selected by moving “DEMO mode” switch to the “9” position.
6. Set the following switches. About the setting contents details of the switch, refer to

“Explanation of the Switches of Setting the Control Data”.

LC75843UGAGEVB

Switches	Functions	Contents Which Are Set
PF0 to PF3	PWM output waveform frame frequency select.	The PWM output waveform frame frequency is 195 [Hz] by moving "PF0, PF1, PF2, PF3" switch to the "L(0), L(0), L(0), L(0)" position.
FC0 to FC3	Common/Segment output waveform frame frequency select.	The common/segment output waveform frame frequency is 97 [Hz] by moving "FC0, FC1, FC2, FC3" switch to the "L(0), H(1), L(0), H(1)" position.
P1	General-purpose output port (S1/P1) function select.	L(0) : Low level output mode
EXF	External clock operating frequency mode select at OC = H(1).	L(0) : 300kHz input operating mode
OC	Fundamental clock operating mode select.	L(0) : Internal oscillator clock operating mode
SC	Display on/off select.	L(0) : Normal display mode
BU	Power saving mode select.	L(0) : Normal mode
W0 to W5	PWM output waveform duty select.	When switch of the "DEMO mode" is set to "9", duty of the PWM output waveform is automatically set, therefore switches of the "W0 to W5" are set to "L(0), L(0), L(0), L(0), L(0), L(0)" position.

- The CCB serial data are transferred from a controller circuit to LCD driver IC by pushing the "Command Set" switch. (The green LED monitor of the "BUSY" and "INH" are turned on)
- The customer can confirm the movement of the LCD display and LED brightness adjustment by

the automatic demonstration. Then, the customer can confirm the waveform of the common outputs (COM1 to COM4), segment outputs (S5 to S24, S28) and general-purpose port outputs (P1 to P4). (The green LED monitor of the "SEND" flashes quickly)

When the Customer's Original Controller Board Is Used

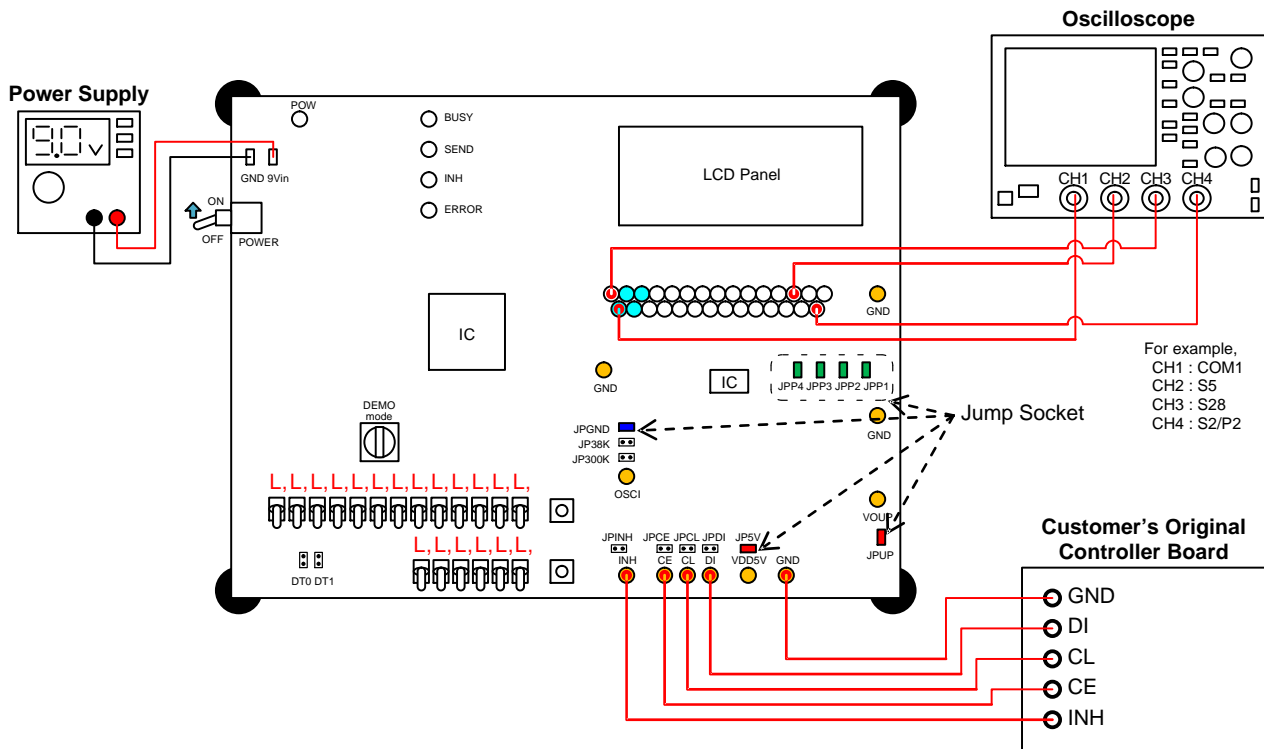

Figure 5. The Test Constitution when the Customer's Original Controller Board Is Used

LC75843UGAGEVB

1. Connect the test setup as shown in Figure 5.
2. Insert the jump sockets of the JP5V, JPGND, JPUP, JPP1, JPP2, JPP3 and JPP4, and remove the jump sockets of the DT0, DT1, JP38K, JP300K, JPINH, JPCE, JPCL and JPDI.
3. The switch does not need to set because the switch on the evaluation board are not used.

4. The power supply of the evaluation board is turned on by moving “POWER” switch to the “ON” position. (The red LED monitor of the “POW” is turned on)
5. The CCB serial data are transferred from a customer’s original controller board to LCD driver IC. The following specification shows the allowable operating ranges of LC75843UGA.

Parameter	Symbol	Min	Typ	Max	Unit
Input High Level Voltage	V_{IH1}	0.4 V_{DD}	–	6.3	V
Input Low Level Voltage	V_{IL1}	0	–	0.2 V_{DD}	V
CCB Serial Clock Operating Frequency	f_{CL}	–	–	3.125	MHz

6. Confirm a result of LCD display and the LED display controlled by the customer’s original controller board. Then, the customer can confirm

the waveform of the common outputs (COM1 to COM4), segment outputs (S5 to S24, S28) and general-purpose port outputs (P1 to P4).

When the LCD Display Is Driven by the External Clock Input

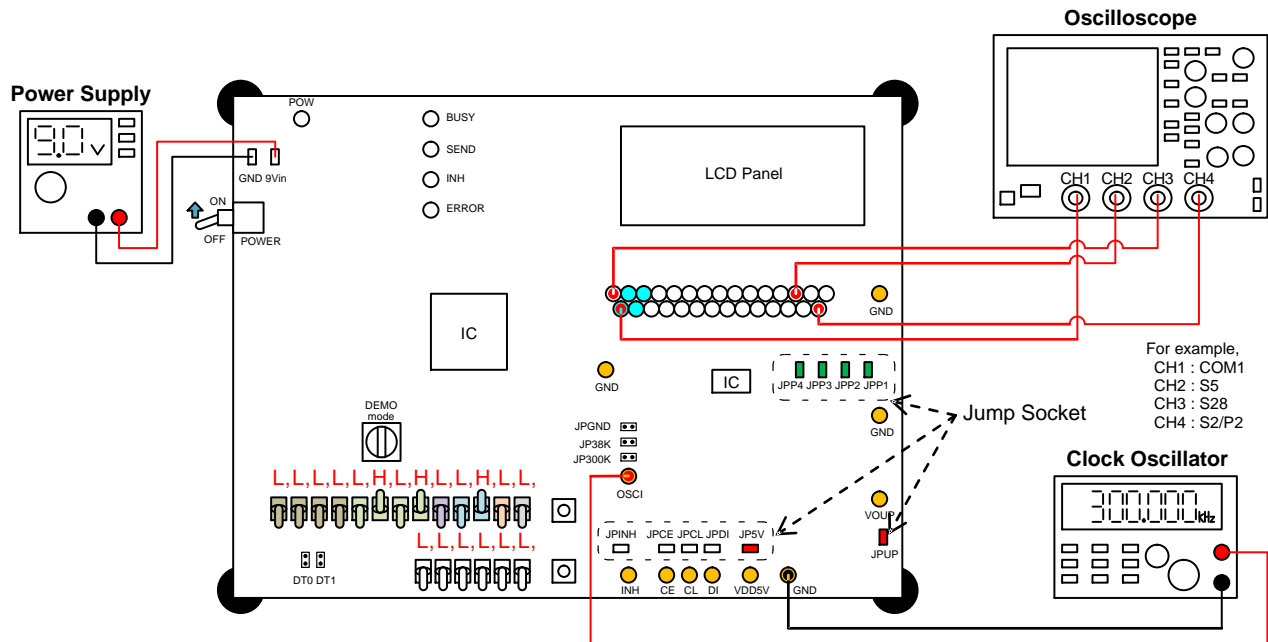

Figure 6. The Test Constitution when the LCD Display Is Driven by the External Clock Input

When the LCD Display Is Driven by the Clock Oscillator

1. Connect the test setup as shown in Figure 6.
2. Insert the jump sockets of the JP5V, JPINH, JPCE, JPCL, JPDI, JPUP, JPP1, JPP2, JPP3 and JPP4, and remove the jump sockets of the DT0, DT1, JPGND, JP38K and JP300K.
3. The power supply of the evaluation board is turned on by moving “POWER” switch to the “ON”

- position. (The red LED monitor of the “POW” is turned on)
4. An automatic demonstration mode is selected by moving “DEMO mode” switch to the “9” position.
5. Set the following switches. About the setting contents details of the switch, refer to “Explanation of the Switches of Setting the Control Data”.

LC75843UGAGEVB

Switches	Functions	Contents Which Are Set
PF0 to PF3	PWM output waveform frame frequency select.	The PWM output waveform frame frequency is 195 [Hz] by moving “PF0, PF1, PF2, PF3” switch to the “L(0), L(0), L(0), L(0)” position.
FC0 to FC3	Common/Segment output waveform frame frequency select.	The common/segment output waveform frame frequency is 97 [Hz] by moving “FC0, FC1, FC2, FC3” switch to the “L(0), H(1), L(0), H(1)” position.
P1	General-purpose output port (S1/P1) function select.	L(0) : Low level output mode
EXF	External clock operating frequency mode select at OC = H(1).	L(0) : 300kHz input operating mode
OC	Fundamental clock operating mode select.	H(1) : External clock operating mode
SC	Display on/off select.	L(0) : Normal display mode
BU	Power saving mode select.	L(0) : Normal mode
W0 to W5	PWM output waveform duty select.	When switch of the “DEMO mode” is set to “9”, duty of the PWM output waveform is automatically set, therefore switches of the “W0 to W5” are set to “L(0), L(0), L(0), L(0), L(0), L(0)” position.

6. Supply the external clock to “OSCI” pin.
The following specification shows the allowable operating ranges of LC75843UGA.

Parameter	Symbol	Min	Typ	Max	Unit
Input High Level Voltage	V_{IH2}	0.4 V_{DD}	–	6.3	V
Input Low Level Voltage	V_{IL2}	0	–	0.2 V_{DD}	V
External Clock Operating Frequency	f_{CK}	10	300	600	kHz
External Clock Duty Cycle	D_{CK}	30	50	70	%

7. The CCB serial data are transferred from a controller circuit to LCD driver IC by pushing the “Command Set” switch. (The green LED monitor of the “BUSY” and “INH” are turned on)
8. The customer can confirm the movement of the LCD display and LED brightness adjustment by the automatic demonstration. Then, the customer can confirm the waveform of the common outputs (COM1 to COM4), segment outputs (S5 to S24, S28) and general-purpose port outputs (P1 to P4).

4. The CCB serial data are transferred from a controller circuit to LCD driver IC by pushing the “Command Set” switch. (The green LED monitor of the “BUSY” and “INH” are turned on)
5. The customer can confirm the movement of the LCD display and LED brightness adjustment by the automatic demonstration. Then, the customer can confirm the waveform of the common outputs (COM1 to COM4), segment outputs (S5 to S24, S28) and general-purpose port outputs (P1 to P4).

When the LCD Display Is Driven by the 300 [kHz] External Clock Input

- The LCD display is turned off by pushing the switch of “Command Set” and “PWM Set” at the same time more than two seconds. (The green LED monitor of the “BUSY” and “INH” are turned off)
- Insert the jump socket of the JP300K, and remove the jump sockets of the JPGND and JP38K. The 301.205 [MHz] (50 MHz × 166 clock) clock output by the controller is input into an LCD driver IC by inserting a jump socket of the JP300K.
- Move “OC” switch to the “H(1)” position and “EXF” switch to the “L(0)” position.

When the LCD Display Is Driven by the 38 [kHz] External Clock Input

- The LCD display is turned off by pushing the switch of “Command Set” and “PWM Set” at the same time more than two seconds. (The green LED monitor of the “BUSY” and “INH” are turned off)
- Insert the jump socket of the JP38K, and remove the jump sockets of the JPGND and JP300K. The 37.994 [MHz] (50 MHz × 1316 clock) clock output by the controller is input into an LCD driver IC by inserting a jump socket of the JP38K.
- Move “OC” switch to the “H(1)” position and “EXF” switch to the “H(1)” position.

LC75843UGAGEVB

- The CCB serial data are transferred from a controller circuit to LCD driver IC by pushing the “Command Set” switch. (The green LED monitor of the “BUSY” and “INH” are turned on)
- The customer can confirm the movement of the LCD display and LED brightness adjustment by

the automatic demonstration. Then, the customer can confirm the waveform of the common outputs (COM1 to COM4), segment outputs (S5 to S24, S28) and general-purpose port outputs (P1 to P4).

When the LCD Display Is Driven Using the LCD Driver IC in All Customer Original Environment

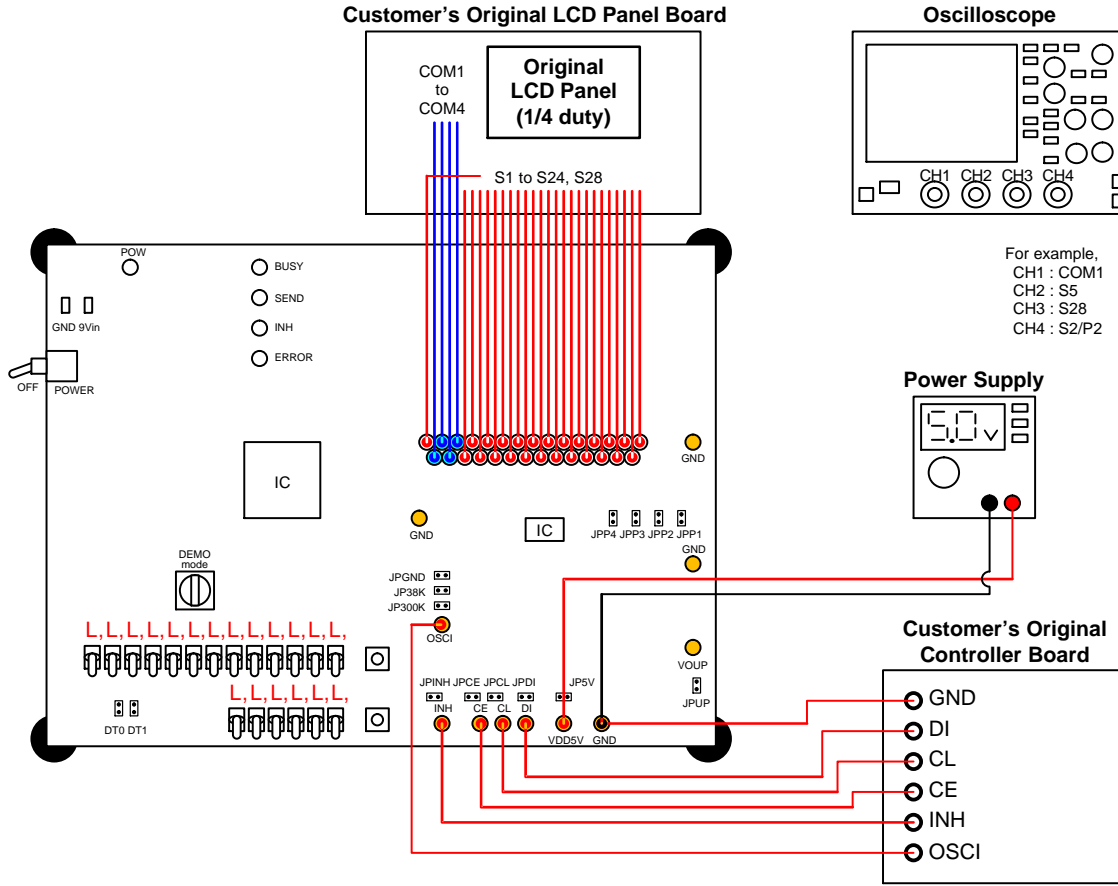
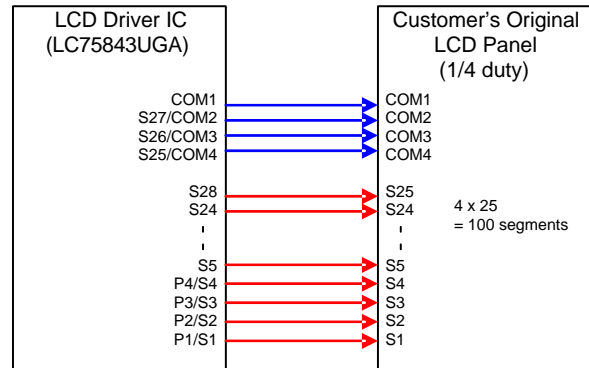

Figure 7. The Test Constitution when the LCD Display Is Driven Using the LCD Driver IC in All Customer Original Environment.

When the Customer's Original LCD Panel of the 1/4 Duty Is Used

When a customer uses the “Customer's original LCD panel”, because the segment allotments of the LCD panel are different the control by the “Customer's original controller board” is necessary. When 1/4 duty drive mode, LC75843UGA can drive the LCD up to 100 segments.



LC75843UGAGEVB

1. Connect the test setup shown in Figure 7.
2. Remove the all jump sockets of the JP5V, JPGND, JP38K, JP300K, DT0, DT1, JPINH, JPCE, JPCL, JPDI, JPUP, JPP1, JPP2, JPP3 and JPP4. However, when the controller circuit in the evaluation board is used, remove the jump sockets of the DT0 and

- DT1. The switch does not need to set because the switch on the evaluation board are not used.
3. Supply the voltage of the external power supply to “VDD5V” pin.

The following specification shows the allowable operating ranges of LC75843UGA.

Parameter	Symbol	Min	Typ	Max	Unit
Power Supply Voltage for LC75843UGA	V _{DD}	4.5	–	6.3	V

4. Supply the external clock to “OSCI” pin, and the CCB serial data are transferred from a customer’s original controller board to LCD driver IC.

The following specification shows the allowable operating ranges of LC75843UGA.

Parameter	Symbol	Min	Typ	Max	Unit
Input High Level Voltage	V _{IH1}	0.4 V _{DD}	–	6.3	V
Input High Level Voltage	V _{IH2}	0.4 V _{DD}	–	6.3	V
Input Low Level Voltage	V _{IL1}	0	–	0.2 V _{DD}	V
Input Low Level Voltage	V _{IL2}	0	–	0.2 V _{DD}	V
CCB Serial Clock Operating Frequency	f _{CL}	–	–	3.125	MHz
External Clock Operating Frequency	f _{CK}	10	300	600	kHz
External Clock Duty Cycle	D _{CK}	30	50	70	%

5. Confirm a result of LCD display and the LED display controlled by the customer’s original controller board. Then, the customer can confirm the waveform of the common outputs (COM1 to COM4), segment outputs (S5 to S24, S28) and general-purpose port and segment outputs (S1/P1 to S4/P4).

JPDI, JPUP and JPP1 to JPP4). However, when the controller circuit in the evaluation board is used, insert the “DT0” jump socket and remove the “DT1” jump socket. The switch does not need to set because the switch on the evaluation board are not used.

When the Customer’s Original LCD Panel of the 1/3 Duty Is Used

When a customer uses the “Customer’s original LCD panel”, because the segment allotments of the LCD panel are different the control by the “Customer’s original controller board” is necessary. When 1/3 duty drive mode, LC75843UGA can drive the LCD up to 78 segments.

When the Customer’s Original LCD Panel of the 1/2 Duty Is Used

When a customer uses the “Customer’s original LCD panel”, because the segment allotments of the LCD panel are different the control by the “Customer’s original controller board” is necessary. When 1/2 duty drive mode, LC75843UGA can drive the LCD up to 54 segments.

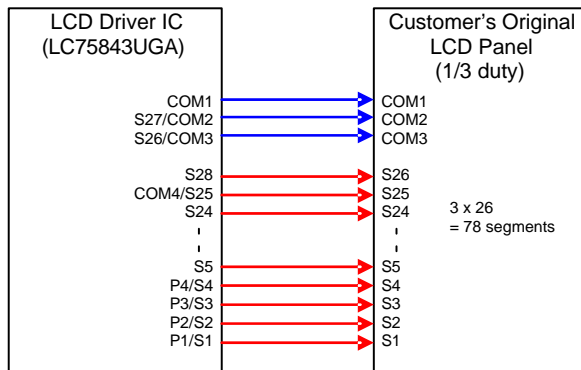

1. Connect the test setup shown in Figure 7. However, an LCD panel of the 1/3 duty is used.
2. Remove the all jump sockets (JP5V, JPGND, JP38K, JP300K, DT0, DT1, JPINH, JPCE, JPCL,

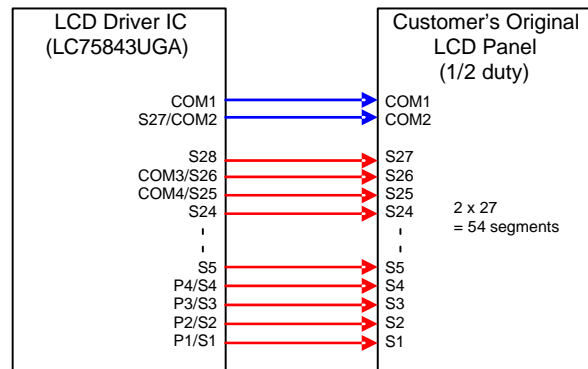

1. Connect the test setup shown in Figure 7. However, an LCD panel of the 1/2 duty is used.
2. Remove the all jump sockets of the JP5V, JPGND, JP38K, JP300K, DT0, DT1, JPINH, JPCE, JPCL, JPDI, JPUP, JPP1, JPP2, JPP3 and JPP4. However,

LC75843UGAGEVB

when the controller circuit in the evaluation board is used, insert the jump socket of the DT1 and remove the jump socket of the DT0. The switch does not need to be set because the switch on the evaluation board are not used.

When the Customer's Original LCD Panel of the Static (1/1 Duty) Is Used

When a customer uses the "Customer's original LCD panel", because the segment allotments of the LCD panel are different the control by the "Customer's original controller board" is necessary. When static (1/1 duty) drive mode, LC75843UGA can drive the LCD up to 28 segments.

1. Connect the test setup shown in Figure 7.
However, an LCD panel of the static (1/1 duty) is used.
2. Remove the all jump sockets of the JP5V, JPGND, JP38K, JP300K, DT0, DT1, JPINH, JPCE, JPCL, JPDI, JPUP, JPP1, JPP2, JPP3 and JPP4. However, when the controller circuit in the evaluation board is used, insert the jump sockets of the DT0 and DT1. The switch does not need to be set because the switch on the evaluation board are not used.

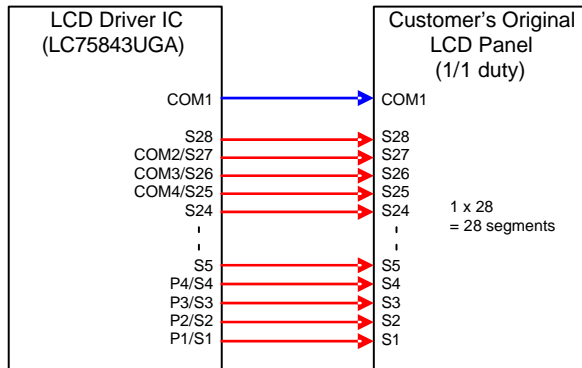

LC75843UGAGEVB

SCHEMATIC

Power Supply Circuit

The power supply circuit of this evaluation board generates three kinds of voltage by a linear regulator IC (LM317) from the power supply voltage of 9 V inputted. The +1.5 V power supply circuit is a power supply for FPGA core, the +3.3 V power supply circuit is a power supply for FPGA I/O and peripheral IC circuits, and the +5.0 V power supply circuit is a power supply for LCD driver IC. The linear regulator IC (LM317) can adjust the output voltage from 1.2 V to 37 V by an external resistor.

The calculating formula of the output voltage:

$$V_{OUT} = 1.25 \times (1 + R_2 / R_1) + I_{ADJ} \times R_2 \text{ [V]}$$

For example,

+1.5 V Power Supply Circuit:

$$V_{OUT1} = 1.25 \times (1 + 51 / 240) + 50 \mu\text{A} \times 51 = 1.518 \text{ V}$$

+3.3 V Power Supply Circuit:

$$V_{OUT2} = 1.25 \times (1 + 390 / 240) + 50 \mu\text{A} \times 390 = 3.301 \text{ V}$$

+5.0 V Power Supply Circuit:

$$V_{OUT3} = 1.25 \times (1 + (360+620) / 330) + 50 \mu\text{A} \times (360 + 620) = 5.011 \text{ V}$$

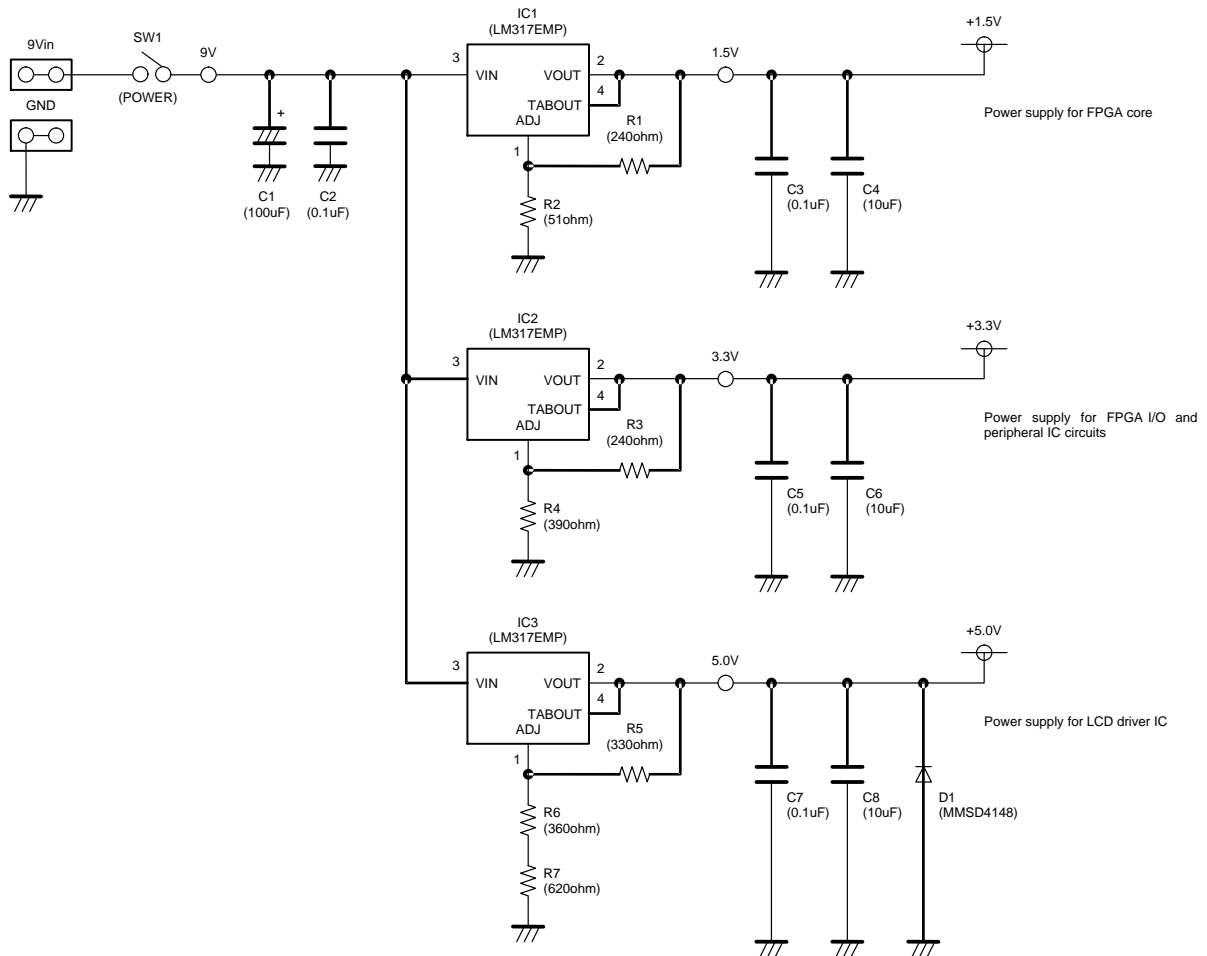

Figure 8. Schematic of Power Supply Circuit

LC75843UGAGEVB

Controller Circuit

The controller circuit of this evaluation board controls LCD driver IC (LC75843UGA) by CCB format serial data (3 V interface) using FPGA. The crystal oscillator circuit (50 [MHz]), power-on reset circuit, configuration ROM circuit, connector for configuration, switch for condition setting, LED monitor circuit and LCD driver IC interface are connected to FPGA.

The LCD driver IC (LC75843UGA) has various control data for condition setting. Serial data are transferred when push SW4 (Command Set) after having set toggle switches

from SW5 to SW23. In addition, PWM data from SW18 to SW23 are set by pushing SW3 (PWM Set) depending on a demonstration mode. Furthermore, the LCD display data for various display and the general-purpose port data for LED control are generated by a demonstration mode chosen by SW2 (DEMO mode). The internal pull-up resistor function of the input pins of FPGA are set to active.

The customer can confirm the operating conditions of the internal circuit of an FPGA by an LED monitor (POW, BUSY, SEND, INH, ERROR).

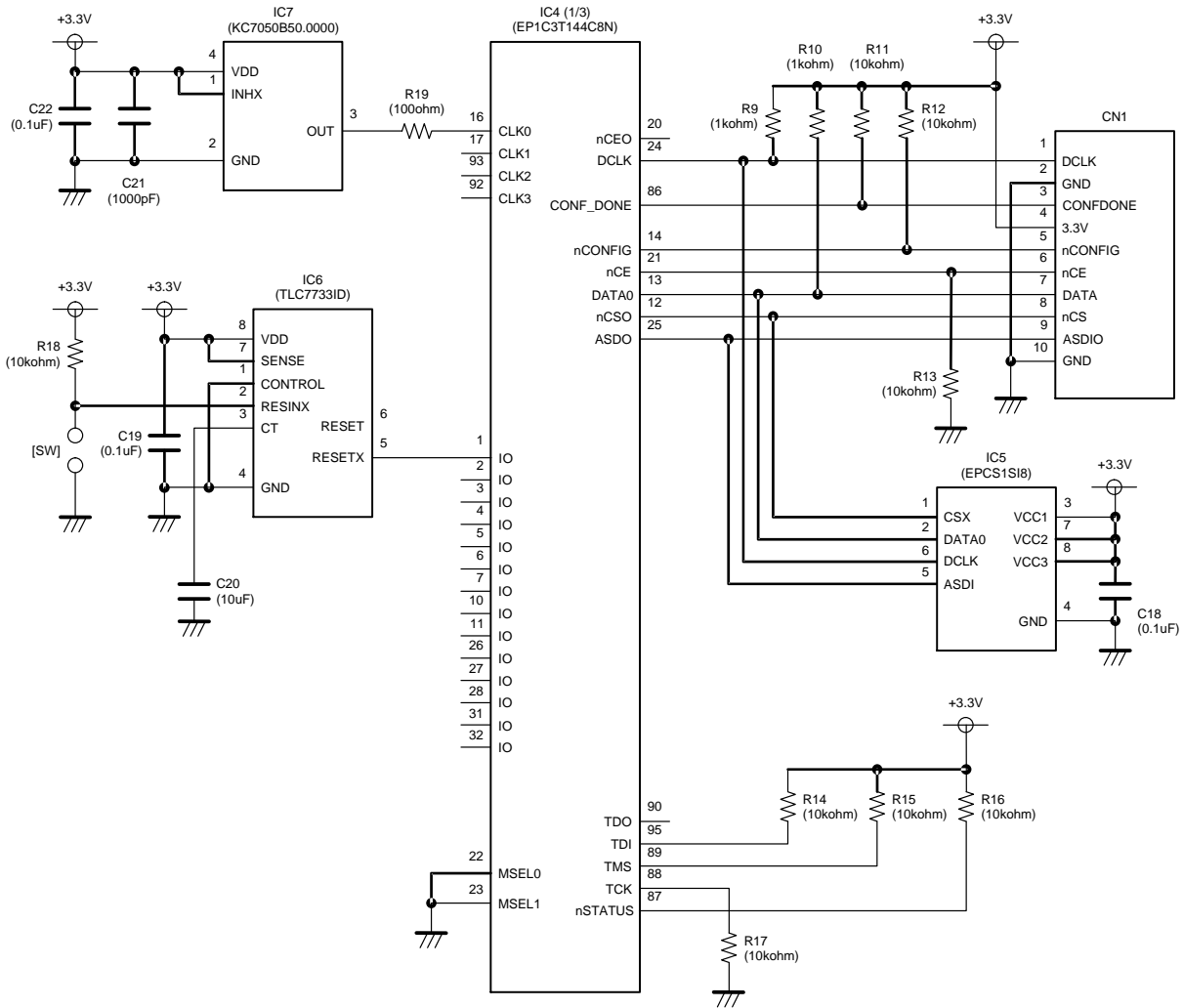

NOTE: The part with a square bracket is not implemented on a board. ([SW])

Figure 9. Schematic of Controller Circuit (1/2)

LC75843UGAGEVB

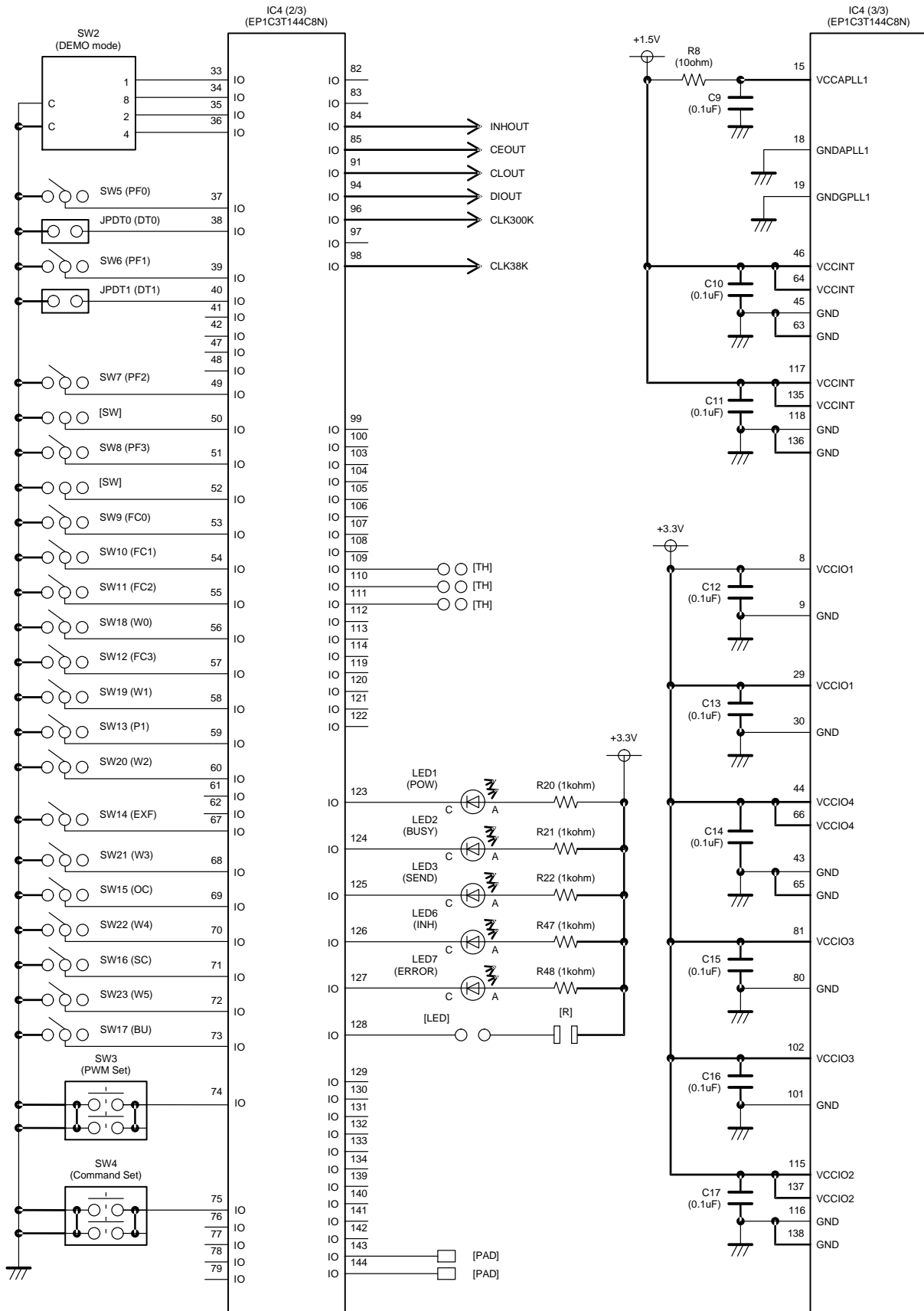

NOTE: The part with a square bracket is not implemented on a board. ([SW], [LED], [R], [TH], [PAD])

Figure 10. Schematic of Controller Circuit (2/2)

LC75843UGAGEVB

LCD Driver IC Circuit

The LCD driver circuit of this evaluation board uses LC75843UGA. The power supply and the control signal supplied from the controller circuit can separate it by removing a jump socket. Thereby, the customer can supply a power supply and a control signal from the external.

The power supply of the LCD driver IC is supplied +5 V voltage by the power supply circuit of this evaluation board. When customer evaluate the voltage other than +5 V, remove the jump socket of the JP5V, and supply power supply to “VDD5V” pin. Insert only one jump socket in a socket pin of the JPGND, JP38K or JP300K for OSCI

signal by setting of control data of the LCD driver IC. When OC is set to L(0), insert the jump socket of the JPGND. When OC is set to H(1) and EXF is set to L(0), insert the jump socket of the JP300K. When OC is set to H(1) and EXF is set to H(1), insert the jump socket of the JP38K.

The resistors from R23 to R29 are the dumping resistance for waveform shaping. In addition, when waveform shaping is more necessary, connect a condenser (for example, from 100 to 1000 pF) to [C]. The resistors from R30 to R34 are pull-down resistor to protect a circuit when a jump socket was removed.

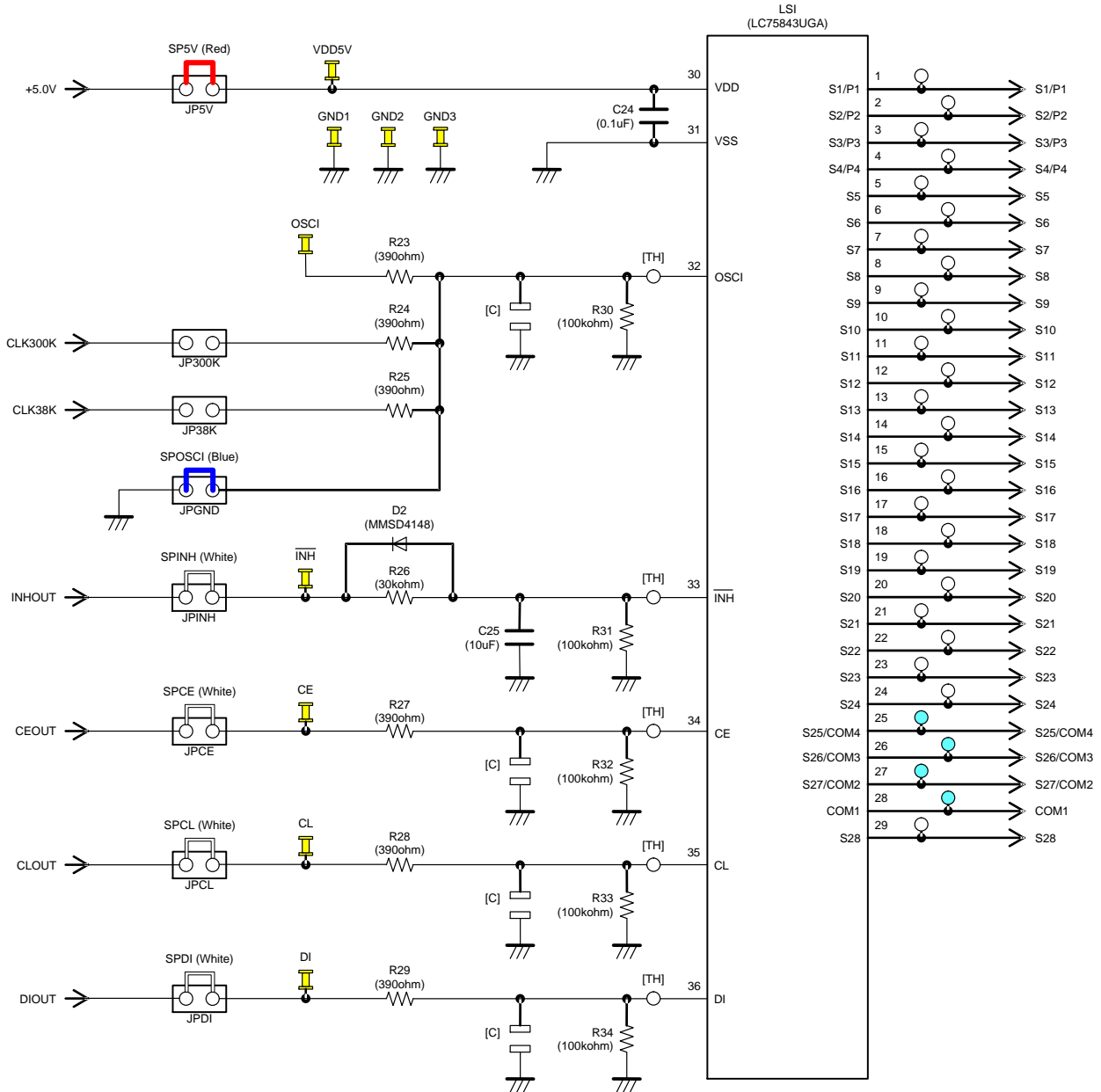

NOTE: The part with a square bracket is not implemented on a board. ([C], [TH])

Figure 11. Schematic of LCD Driver IC Circuit

LC75843UGAGEVB

LCD Panel Circuit

The LCD panel circuit of this evaluation board uses a socket pin, and LCD panel made in varitronix is inserted there. The specifications of the LCD panel are four common pins, 32 segment pins, twisted nematic (TN) type, reflection type, alphanumeric character display and 70.00 mm × 25.00 mm × 2.80 mm.

Four common output signals and 21 segment output signals of the LCD driver IC are connected to an LCD panel.

Because S28 output is connected to twelve segments of the LCD panel, the customer can confirm the waveform of big load. About the segment allotment of the LCD panel, refer to "LCD Panel Segment Allotment".

When customer evaluate the display system using the customer's original LCD panel, remove an inserted LCD panel, and connect a customer's original LCD panel.

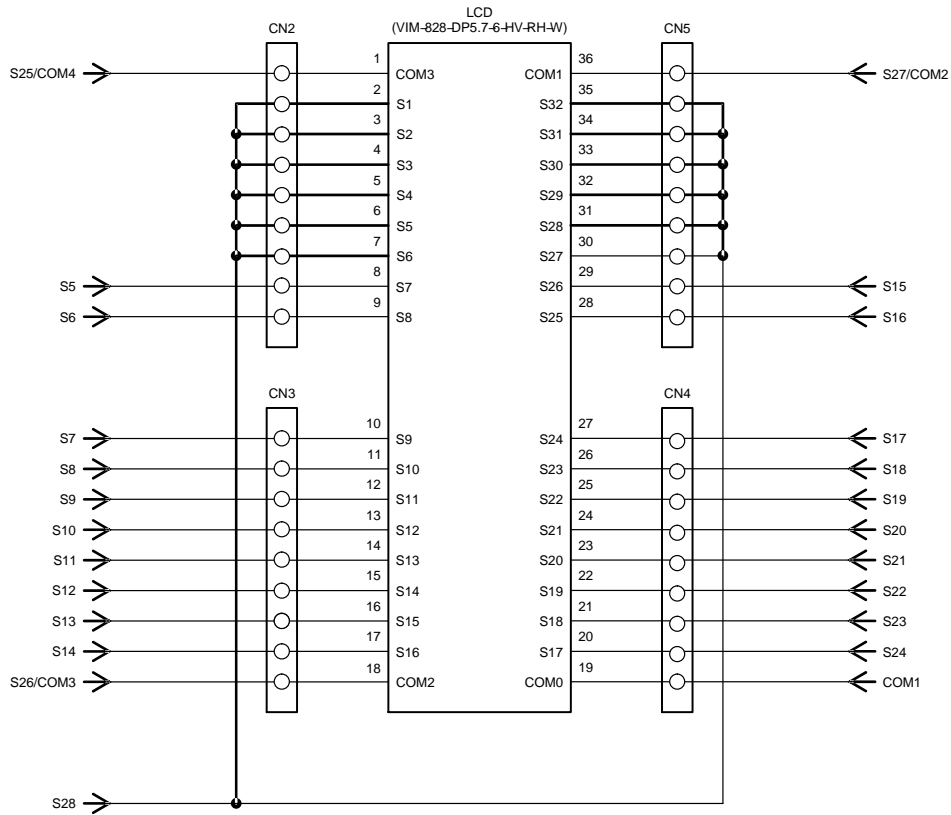

Figure 12. Schematic of LCD Panel Circuit

LC75843UGAGEVB

LED Circuit

The LED circuit of this evaluation board uses a single color LED and three color (RGB) LED. The LED is controlled by the general-purpose port output of LCD driver IC (LC75843UGA). The general-purpose port output has up to four, and brightness adjustment (64 steps) is possible by PWM output function of up to 3-channel.

The pull-up power supply of the LED is supplied +5 V voltage by the power supply circuit of this evaluation board. When customer evaluate the voltage other than +5 V, remove the jump socket of the JPUP, and supply pull-up power supply to “VOUP” pin.

When customer uses general-purpose port outputs (S1/P1 to S4/P4) of LCD driver IC (LC75843UGA) as a segment

output, remove the jump sockets from JPP1 to JPP4. The resistors from R35 to R38 are pull-down resistor to protect a circuit when a jump socket was removed.

The calculating formula of the LED current:

$$IF = (VOUP - VF - V_{sat}) / R [A]$$

For example,

LED5 (P1): $IF1 = (5 - 1.9 - 0.1) / 200 = 15.0 \text{ mA}$

LED4 (P2(R)): $IF2 = (5 - 2.0 - 0.1) / 200 = 14.5 \text{ mA}$

LED4 (P3(G)): $IF3 = (5 - 3.5 - 0.1) / 91 = 15.4 \text{ mA}$

LED4 (P4(B)): $IF4 = (5 - 3.6 - 0.1) / 82 = 15.8 \text{ mA}$

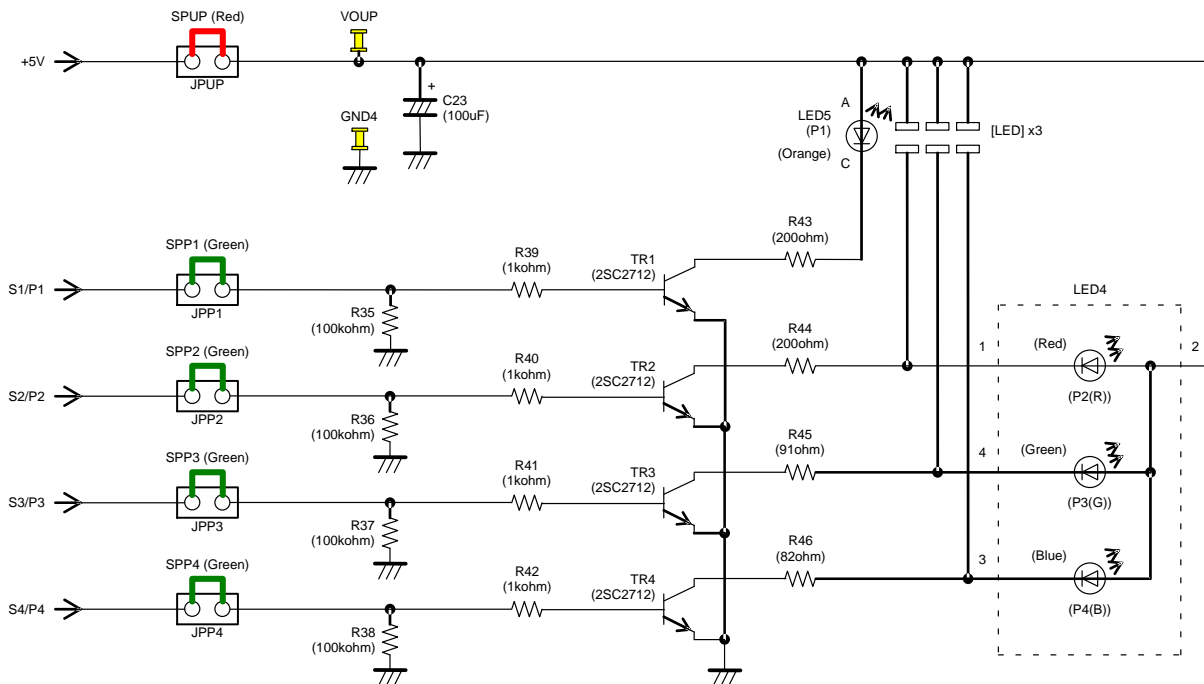









NOTE: The part with a square bracket is not implemented on a board. ([LED])

Figure 13. Schematic of LED Circuit

LC75843UGAGEVB

PIN FUNCTIONS

Table 2. PIN FUNCTIONS OF LC75843UGA EVALUATION BOARD (LC75843UGAGEVB)

Pin Name	Functions	I/O	Control Jump Socket
VDD5V	Power supply pin for LCD driver IC (LC75843UGA). When supply the power supply voltage from the external, remove the jump socket of the JP5V. When the power supply circuit in the evaluation board is used, the +5.0 [V] voltage is outputted.	I/O	JP5V 
VOUP	Pull-up power supply pin for LED. When supply the pull-up power supply voltage from the external, remove the jump socket of the JPUP. When the power supply circuit in the evaluation board is used, the +5.0 [V] voltage is outputted.	I/O	JPUP 
GND	Ground pin. Must be connected to ground of all external equipments.	—	GND 
OSCI	External clock input pin. When OC is set to L(0), insert the jump socket of the JPGND. When OC is set to H(1) and EXF is set to L(0), insert the jump socket of the JP300K. When OC is set to H(1) and EXF is set to H(1), insert the jump socket of the JP38K.	I/O	JPGND, JP38K, JP300K 
$\overline{\text{INH}}$	Display forced off control input pin. When input the $\overline{\text{INH}}$ signal from the external, remove the jump socket of the JPINH.	I/O	JPINH 
CE	Chip enable signal input pin of the CCB format. When input the CE signal from the external, remove the jump socket of the JPCE.	I/O	JPCE 
CL	Synchronization clock signal input pin of the CCB format. When input the CL signal from the external, remove the jump socket of the JPCL.	I/O	JPCL 
DI	Serial data signal input pin of the CCB format. When input the DI signal from the external, remove the jump socket of the JPD1.	I/O	JPD1 
S1/P1 to S4/P4	Segment outputs or general-purpose port outputs pin. The pins from S1/P1 to S4/P4 can be used as a general-purpose port output by setting of CCB serial data. When the general-purpose port output is used for a segment function in the evaluation environment of the customer's original, remove the jump sockets from JPP1 to JPP4.	O	JPP1 to JPP4 
S5 to S24, S28	Segment output pins.	O	—
COM1	Common output pin.	O	—
COM2/S27, COM3/S26, COM4/S25	Common output or segment output pins. The pins from COM2/S27 to COM4/S25 can be used as a segment output by setting of CCB serial data.	O	—

LC75843UGAGEVB

SETTING METHOD OF THE SWITCH

“DEMO Mode” Rotary Switch







This evaluation board has the demonstration mode which automatically performs LCD display and LED control by

controller control. The customer can select various demonstration contents by the “DEMO mode” rotary switch. The following tables shows the setting contents of the “DEMO mode” rotary switch.

When the jump sockets of the DT0 and DT1 were set for the setting that was not 1/4 duty drive, the “DEMO mode” can use only a mode of “0”, “1”, “4” and “5”. In addition, when “DEMO mode” was set to “2”, “3”, “6”, “7”, “8” and “9”, the controller is ignored without operating.

Table 3. SETTING CONTENTS OF THE “DEMO MODE” ROTARY SWITCH

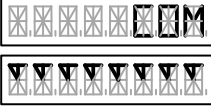
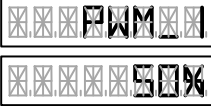
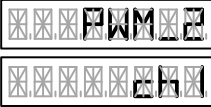
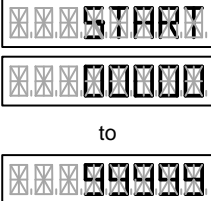
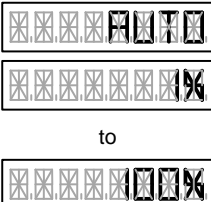
“DEMO Mode” Rotary Switch	Demonstration Item	LCD Display Contents	LED Control Contents
0	All OFF Test	All segments are off. 	All LED turn off the light.
1	All ON Test	All segments are on. 	All LED turn on the light. (100% brightness)
2	LCD Display Test (1)	The LCD displays a “01234”. 	All LED turn off the light.
3	LCD Display Test (2)	The LCD displays a “AbcdE”. 	All LED turn off the light.
4	Segment Test	The segment of the LCD displays on in turn. 	LED does on in turn.
5	Common Test	LCD segment corresponding to same COM are all on. 	When COM1 is on, LED turn on the light.
6	LED (PWM) Test (1)	The LCD displays a “PWM_1” and a PWM duty value. 	Any PWM duty are selected by the switches from W0 to W5. (LED1 to LED3 can set same duty)
7	LED (PWM) Test (2)	The LCD displays a “PWM_2” and a PWM channel number. 	Any PWM duty are selected by the switches from W0 to W5. (LED1 to LED3 can set each duty)
8	Demonstration (1)	LCD number display count ups every second. 	LED does on in turn every second.
9	Demonstration (2)	The LCD displays a “AUTO” and a PWM duty value. 	PWM duty changes every 100 ms

LC75843UGAGEVB

Toggle Switch and Push Switch Allotment



The LCD driver IC (LC75843UGA) has various control data for condition setting. Serial data are transferred when push SW4 (Command Set) after having set toggle switches from SW5 (PF0) to SW23 (W5). In addition, PWM data from SW18 (W0) to SW23 (W5) are set by pushing SW3 (PWM Set) depending on a demonstration mode.

Table 4. SETTING CONTENTS OF THE TOGGLE SWITCH

Parts Symbol	Silk Characters	Functions	Control Data of the LCD Driver IC (LC75843UGA)
SW5	PF0	The switches for setting of the PWM output waveform frame frequency	PF0
SW6	PF1		PF1
SW7	PF2		PF2
SW8	PF3		PF3
SW9	FC0	The switches for setting of the common/segment output waveform frame frequency	FC0
SW10	FC1		FC1
SW11	FC2		FC2
SW12	FC3		FC3
SW13	P1	The switch for setting of the general-purpose output port (S1/P1) function	D1, PS10, PS11
SW14	EXF	The switch for setting of the external clock operating frequency	EXF
SW15	OC	The switch for setting of the internal oscillator operating mode/external clock operating mode	OC
SW16	SC	The switch for setting of the on/off state of the segments	SC
SW17	BU	The switch for setting of the normal mode/power-saving mode	BU
SW18 to SW23	W0 to W5	The switches for setting of the PWM data of the PWM output	W0 to W5
JPDT0, JPDT1	DT0, DT1	The sockets for setting of the LCD drive scheme (1/1 to 1/4 duty drive)	DT0, DT1

LC75843UGAGEVB

EXPLANATION OF THE SWITCHES OF SETTING THE CONTROL DATA

The Switches for Setting of the PWM Output Waveform Frame Frequency (PF0 to PF3)

Table 5. EXPLANATION OF THE PF0 TO PF3 TOGGLE SWITCH

Switches				Internal Oscillator Operating Mode ($f_{osc} = 300$ [kHz] typ.) (OC = "L(0)")	300 [kHz] External Clock Operating Mode (OC = "H(1)", EXF = "L(0)")	38 [kHz] External Clock Operating Mode (OC = "H(1)", EXF = "H(1)")
PF0	PF1	PF2	PF3			
L(0)	L(0)	L(0)	L(0)	195 [Hz]	195 [Hz]	When OC = "1" and EXF = "1" were set to the LCD driver IC, because the LCD driver IC cannot use PWM output function, this setting is ignored.
H(1)	L(0)	L(0)	L(0)	213 [Hz]	213 [Hz]	
L(0)	H(1)	L(0)	L(0)	234 [Hz]	234 [Hz]	
H(1)	H(1)	L(0)	L(0)	260 [Hz]	260 [Hz]	
L(0)	L(0)	H(1)	L(0)	293 [Hz]	293 [Hz]	
H(1)	L(0)	H(1)	L(0)	335 [Hz]	335 [Hz]	
L(0)	H(1)	H(1)	L(0)	390 [Hz]	390 [Hz]	
H(1)	H(1)	H(1)	L(0)	469 [Hz]	469 [Hz]	
L(0)	L(0)	L(0)	H(1)	586 [Hz]	586 [Hz]	
H(1)	L(0)	L(0)	H(1)	781 [Hz]	781 [Hz]	
L(0)	H(1)	L(0)	H(1)	1171 [Hz]	1171 [Hz]	
H(1)	H(1)	L(0)	H(1)	335 [Hz]	335 [Hz]	
L(0)	L(0)	H(1)	H(1)			
H(1)	L(0)	H(1)	H(1)			
L(0)	H(1)	H(1)	H(1)			
H(1)	H(1)	H(1)	H(1)			

The Switches for Setting of the Common/Segment Output Waveform Frame Frequency (FC0 to FC3)

Table 6. EXPLANATION OF THE FC0 TO FC3 TOGGLE SWITCH

Switches				Internal Oscillator Operating Mode ($f_{osc} = 300$ [kHz] typ.) (OC = "L(0)")	300 [kHz] External Clock Operating Mode (OC = "H(1)", EXF = "L(0)")	38 [kHz] External Clock Operating Mode (OC = "H(1)", EXF = "H(1)")
FC0	FC1	FC2	FC3			
L(0)	L(0)	L(0)	L(0)	49 [Hz]	49 [Hz]	49 [Hz]
L(0)	L(0)	L(0)	H(1)	56 [Hz]	56 [Hz]	56 [Hz]
L(0)	L(0)	H(1)	L(0)	65 [Hz]	65 [Hz]	66 [Hz]
L(0)	L(0)	H(1)	H(1)	78 [Hz]	78 [Hz]	79 [Hz]
L(0)	H(1)	L(0)	L(0)	87 [Hz]	87 [Hz]	88 [Hz]
L(0)	H(1)	L(0)	H(1)	97 [Hz]	97 [Hz]	99 [Hz]
L(0)	H(1)	H(1)	L(0)	111 [Hz]	111 [Hz]	113 [Hz]
L(0)	H(1)	H(1)	H(1)	130 [Hz]	130 [Hz]	132 [Hz]
H(1)	L(0)	L(0)	L(0)	142 [Hz]	142 [Hz]	144 [Hz]
H(1)	L(0)	L(0)	H(1)	156 [Hz]	156 [Hz]	158 [Hz]
H(1)	L(0)	H(1)	L(0)	173 [Hz]	173 [Hz]	176 [Hz]
H(1)	L(0)	H(1)	H(1)	195 [Hz]	195 [Hz]	198 [Hz]
H(1)	H(1)	L(0)	L(0)	223 [Hz]	223 [Hz]	226 [Hz]
H(1)	H(1)	L(0)	H(1)	260 [Hz]	260 [Hz]	264 [Hz]
H(1)	H(1)	H(1)	L(0)	312 [Hz]	312 [Hz]	316 [Hz]
H(1)	H(1)	H(1)	H(1)	390 [Hz]	390 [Hz]	396 [Hz]

LC75843UGAGEVB

The Switch for Setting of the General-purpose Output Port (S1/P1) Function (P1)

Table 7. EXPLANATION OF THE P1 TOGGLE SWITCH

Switch	Control Data of the LCD Driver IC (LC75843UGA)			Operating Contents
	D1	PS10	PS10	
P1				
L(0)	0	0	0	The LED(P1) is Turned Off
H(1)	1	0	0	The LED(P1) is Turned On

The Switch for Setting of the Internal Oscillator Operating Mode/External Clock Operating Mode (OC and EXF)

Table 8. EXPLANATION OF THE OC AND EXF TOGGLE SWITCH

Switches		Clock Operating Mode	Control Jump Socket
OC	EXF		
L(0)	L(0)	Internal Oscillator Operating Mode	Insert the Jump Socket of the JPGND
L(0)	H(1)		
H(1)	L(0)	300 [kHz] External Clock Operating Mode	Insert the Jump Socket of the JP300K
H(1)	H(1)	38 [kHz] External Clock Operating Mode	insert the Jump Socket of the JP38K

The Switch for Setting of the On/Off State of the Segments (SC)

Table 9. EXPLANATION OF THE SC TOGGLE SWITCH

Switch	Operating Contents
SC	
L(0)	Normal Display
H(1)	All Segments are OFF Waveform Drive

The Switch for Setting of the Normal Mode/Power-saving Mode (BU)

Table 10. EXPLANATION OF THE BU TOGGLE SWITCH

Switch	Operating Contents
BU	
L(0)	Normal Mode
H(1)	Power Saving Mode

LC75843UGAGEVB

The Switches for Setting of the PWM Data of the PWM Output (W0 to W5)

Table 11. EXPLANATION OF THE W0 TO W5 TOGGLE SWITCH

Switches						PWM Duty of the General-purpose Port Output
W0	W1	W2	W3	W4	W5	
L(0)	L(0)	L(0)	L(0)	L(0)	L(0)	1/64 (1.56%)
H(1)	L(0)	L(0)	L(0)	L(0)	L(0)	2/64 (3.12%)
L(0)	H(1)	L(0)	L(0)	L(0)	L(0)	3/64 (4.69%)
H(1)	H(1)	L(0)	L(0)	L(0)	L(0)	4/64 (6.25%)
L(0)	L(0)	H(1)	L(0)	L(0)	L(0)	5/64 (7.81%)
H(1)	L(0)	H(1)	L(0)	L(0)	L(0)	6/64 (9.38%)
L(0)	H(1)	H(1)	L(0)	L(0)	L(0)	7/64 (10.94%)
H(1)	H(1)	H(1)	L(0)	L(0)	L(0)	8/64 (12.50%)
L(0)	L(0)	L(0)	H(1)	L(0)	L(0)	9/64 (14.06%)
H(1)	L(0)	L(0)	H(1)	L(0)	L(0)	10/64 (15.62%)
L(0)	H(1)	L(0)	H(1)	L(0)	L(0)	11/64 (17.19%)
H(1)	H(1)	L(0)	H(1)	L(0)	L(0)	12/64 (18.75%)
L(0)	L(0)	H(1)	H(1)	L(0)	L(0)	13/64 (20.31%)
H(1)	L(0)	H(1)	H(1)	L(0)	L(0)	14/64 (21.87%)
L(0)	H(1)	H(1)	H(1)	L(0)	L(0)	15/64 (23.44%)
H(1)	H(1)	H(1)	H(1)	L(0)	L(0)	16/64 (25.00%)
L(0)	L(0)	L(0)	L(0)	H(1)	L(0)	17/64 (26.56%)
H(1)	L(0)	L(0)	L(0)	H(1)	L(0)	18/64 (28.12%)
L(0)	H(1)	L(0)	L(0)	H(1)	L(0)	19/64 (29.69%)
H(1)	H(1)	L(0)	L(0)	H(1)	L(0)	20/64 (31.25%)
L(0)	L(0)	H(1)	L(0)	H(1)	L(0)	21/64 (32.81%)
H(1)	L(0)	H(1)	L(0)	H(1)	L(0)	22/64 (34.37%)
L(0)	H(1)	H(1)	L(0)	H(1)	L(0)	23/64 (35.94%)
H(1)	H(1)	H(1)	L(0)	H(1)	L(0)	24/64 (37.50%)
L(0)	L(0)	L(0)	H(1)	H(1)	L(0)	25/64 (39.06%)
H(1)	L(0)	L(0)	H(1)	H(1)	L(0)	26/64 (40.62%)
L(0)	H(1)	L(0)	H(1)	H(1)	L(0)	27/64 (42.19%)
H(1)	H(1)	L(0)	H(1)	H(1)	L(0)	28/64 (43.75%)
L(0)	L(0)	H(1)	H(1)	H(1)	L(0)	29/64 (45.31%)
H(1)	L(0)	H(1)	H(1)	H(1)	L(0)	30/64 (46.87%)
L(0)	H(1)	H(1)	H(1)	H(1)	L(0)	31/64 (48.44%)
H(1)	H(1)	H(1)	H(1)	H(1)	L(0)	32/64 (50.00%)
L(0)	L(0)	L(0)	L(0)	L(0)	H(1)	33/64 (51.56%)
H(1)	L(0)	L(0)	L(0)	L(0)	H(1)	34/64 (53.12%)
L(0)	H(1)	L(0)	L(0)	L(0)	H(1)	35/64 (54.69%)
H(1)	H(1)	L(0)	L(0)	L(0)	H(1)	36/64 (56.25%)
L(0)	L(0)	H(1)	L(0)	L(0)	H(1)	37/64 (57.81%)
H(1)	L(0)	H(1)	L(0)	L(0)	H(1)	38/64 (59.37%)
L(0)	H(1)	H(1)	L(0)	L(0)	H(1)	39/64 (60.94%)
H(1)	H(1)	H(1)	L(0)	L(0)	H(1)	40/64 (62.50%)

LC75843UGAGEVB

Table 11. EXPLANATION OF THE W0 TO W5 TOGGLE SWITCH (continued)

Switches						PWM Duty of the General-purpose Port Output
W0	W1	W2	W3	W4	W5	
L(0)	L(0)	L(0)	H(1)	L(0)	H(1)	41/64 (64.06%)
H(1)	L(0)	L(0)	H(1)	L(0)	H(1)	42/64 (65.62%)
L(0)	H(1)	L(0)	H(1)	L(0)	H(1)	43/64 (67.19%)
H(1)	H(1)	L(0)	H(1)	L(0)	H(1)	44/64 (68.75%)
L(0)	L(0)	H(1)	H(1)	L(0)	H(1)	45/64 (70.31%)
H(1)	L(0)	H(1)	H(1)	L(0)	H(1)	46/64 (71.87%)
L(0)	H(1)	H(1)	H(1)	L(0)	H(1)	47/64 (73.44%)
H(1)	H(1)	H(1)	H(1)	L(0)	H(1)	48/64 (75.00%)
L(0)	L(0)	L(0)	L(0)	H(1)	H(1)	49/64 (76.56%)
H(1)	L(0)	L(0)	L(0)	H(1)	H(1)	50/64 (78.12%)
L(0)	H(1)	L(0)	L(0)	H(1)	H(1)	51/64 (79.69%)
H(1)	H(1)	L(0)	L(0)	H(1)	H(1)	52/64 (81.25%)
L(0)	L(0)	H(1)	L(0)	H(1)	H(1)	53/64 (82.81%)
H(1)	L(0)	H(1)	L(0)	H(1)	H(1)	54/64 (84.37%)
L(0)	H(1)	H(1)	L(0)	H(1)	H(1)	55/64 (85.94%)
H(1)	H(1)	H(1)	L(0)	H(1)	H(1)	56/64 (87.50%)
L(0)	L(0)	L(0)	H(1)	H(1)	H(1)	57/64 (89.06%)
H(1)	L(0)	L(0)	H(1)	H(1)	H(1)	58/64 (90.62%)
L(0)	H(1)	L(0)	H(1)	H(1)	H(1)	59/64 (92.19%)
H(1)	H(1)	L(0)	H(1)	H(1)	H(1)	60/64 (93.75%)
L(0)	L(0)	H(1)	H(1)	H(1)	H(1)	61/64 (95.31%)
H(1)	L(0)	H(1)	H(1)	H(1)	H(1)	62/64 (96.87%)
L(0)	H(1)	H(1)	H(1)	H(1)	H(1)	63/64 (98.44%)
H(1)	H(1)	H(1)	H(1)	H(1)	H(1)	64/64 (100.00%)

LC75843UGAGEVB

EXPLANATION OF THE JUMP SOCKETS OF SETTING THE CONTROL DATA

The Sockets for Setting of the LCD Drive Scheme (1/1 to 1/4 Duty Drive) (DT0 and DT1)



When a customer uses the “Customer’s original LCD panel”, because the segment allotments of the LCD panel are different the control by the “Customer’s original controller board” is necessary.

When the controller circuit in the evaluation board and the 1/4 duty LCD panel are used, remove the jump sockets of the DT0 and DT1.

When the controller circuit in the evaluation board and the 1/3 duty LCD panel are used, insert the jump socket of the DT0 and remove the jump socket of the DT1.

When the controller circuit in the evaluation board and the 1/2 duty LCD panel are used, insert the jump socket of the DT1 and remove the jump socket of the DT0.

When the controller circuit in the evaluation board and the static (1/1 duty) LCD panel are used, insert the jump sockets of the DT0 and DT1.

When the jump sockets of the DT0 and DT1 were set for the setting that was not 1/4 duty drive, the “DEMO mode” can use only a mode of “0”, “1”, “4” and “5”. In addition, when “DEMO mode” was set to “2”, “3”, “6”, “7”, “8” and “9”, the controller is ignored without operating, and the LED of the “ERROR” is turned on.

Table 12. EXPLANATION OF THE DT0 AND DT1 JUMP SOCKETS





Jump Sockets		Control Data of the LCD Driver IC (LC75843UGA)		Operating Contents
DT0	DT1	DT0	DT1	
Remove	Remove	0	0	1/4 Duty Drive Scheme
Insert	Remove	1	0	1/3 Duty Drive Scheme
Remove	Insert	0	1	1/2 Duty Drive Scheme
Insert	Insert	1	1	Static (1/1 Duty) Drive Scheme

EXPLANATION OF THE LED MONITOR OF THE CONTROLLER CIRCUIT

The LED monitor circuit is connected to FPGA. The customer can confirm the operating conditions of the

internal circuit of an FPGA by an LED monitor of the POW, BUSY, SEND, INH and ERROR.

Table 13. EXPLANATION OF THE LED MONITOR

Symbol	Functions
POW 	LED monitor for main power supply ON/OFF. The power supply is supplied by moving “POWER” switch to the “ON” position, and the LED of the “POW” is turned on when FPGA operated normally.
BUSY 	LED monitor for during the demonstration. The automatic demonstration mode is selected by moving “DEMO mode” switch to the “8” or “9” positions, and the LED of the “BUSY” is turned on when a demonstration is started.
SEND 	LED monitor for CCB serial data transfer. The LED of the “SEND” is turned on when the CCB serial data are transferred by a demonstration or pushing the switches of the “Command Set” or “PWM Set”.
INH 	LED monitor for INH signal state. The LED of the “INH” is turned on when INH output is outputted to high level.
ERROR 	LED monitor for the setting state error of the switches. The LED of the “ERROR” is turned on, when the setting of the switch of the “DEMO mode” and the setting of the jump socket of the “Duty” included an error. At the time of error, the CCB serial data are not transferred even if pushing the switches of the “Command Set” or “PWM Set”.

ABOUT THE PERIPHERAL CIRCUITS OF THE $\overline{\text{INH}}$ SIGNAL

The $\overline{\text{INH}}$ signal after turning on the power supply is outputted to low level. After having pushed the first “Command Set” switch at the time of state that the $\overline{\text{INH}}$ signal is low level, the CCB serial data is transferred. Afterwards, the $\overline{\text{INH}}$ signal is outputted to high level. In

addition, the $\overline{\text{INH}}$ signal is outputted to low level when pushes the switch of “Command Set” and the switch of “PWM Set” at the same time more than two seconds. At this time, the setting of CCB serial data is kept.

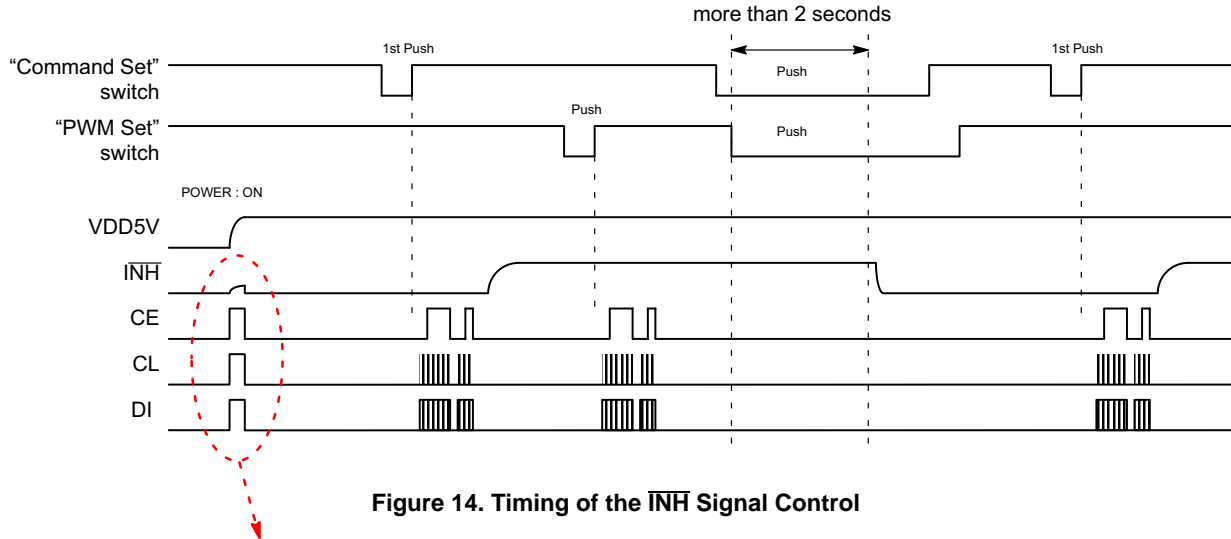

Figure 14. Timing of the $\overline{\text{INH}}$ Signal Control

However, when during execution of the reset just after the power supply (Before execution of the configuration) and during execution of the configuration, the user I/O pin of FPGA used by the controller circuit of this evaluation board is the specifications that high level is outputted (the user I/O pin are used for CE, CL, DI, $\overline{\text{INH}}$ and the OSCI output).

When the $\overline{\text{INH}}$ signal is high level, the LCD driver IC becomes the display ON state. This may cause false display of the LCD.

This evaluation board constitutes CR filter circuit by resistor (R26) and capacitor (C25), and the $\overline{\text{INH}}$ signal pulse just after power supply on is removed. When falling of the $\overline{\text{INH}}$ signal or falling of the power supply, diode (D2) is used to rapidly discharge the electric charge of the capacitor. The resistor (R31) is pull-down resistor to protect a circuit when a jump socket was removed.

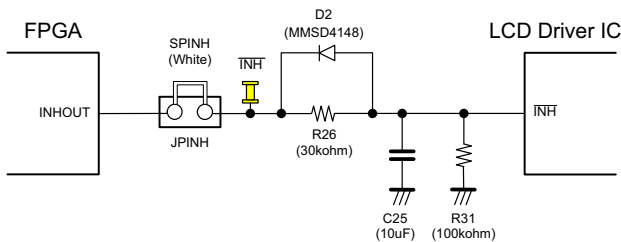

Figure 15. Peripheral Circuit of the $\overline{\text{INH}}$ Signal

Pulse width just after the power supply on
: $t_1 = \text{about } 100 \text{ [ms]}$

The specifications of the input low level of the INH signal
: $V_{\text{IL}} = 0.2 V_{\text{DD}} \text{ [V]}(\text{max})$

Output signal level of FPGA
: $V_{\text{OFFPGA}} = 3.3 \text{ [V]}$

Power supply voltage of the LCD driver IC
: $V_{\text{DD}} = 5.0 \text{ [V]}$

The calculation example of CR filter circuit using resistance value and capacitance value is shown in the following equations.

$$V_{\text{IL}} = V_{\text{OFFPGA}} \times (1 - e^{-(1/RC) \times t}) \text{ [V]}$$

$$R \times C = - \left[\frac{t_1}{\ln\left(\frac{V_{\text{OFFPGA}} - V_{\text{IL}}}{V_{\text{OFFPGA}}}\right)} \right] = - \left[\frac{0.1}{\ln\left(\frac{3.3 - 0.2 \times 5}{3.3}\right)} \right] = 0.277$$

For example, when capacitor (C25) is 10 μF , resistor (R26) is 27.7 $\text{k}\Omega$... Consequently, 30 $\text{k}\Omega$ choice.

LC75843UGAGEVB

The rise time to the input High level of the $\overline{\text{INH}}$ signal is shown in the following equations.

$$V_{IL} = V_{\text{OFFPGA}} \times (1 - \epsilon^{-(1/RC) \times t}) [V]$$

$$t_1 = - \left(R \times C \times \ln \left(\frac{V_{\text{OFFPGA}} - V_{IL}}{V_{\text{OFFPGA}}} \right) \right) =$$

$$= - \left(30 \times 10^3 \times 10 \times 10^{-6} \times \ln \left(\frac{3.3 - 0.4 \times 5}{3.3} \right) \right) =$$

$$= 279.5 \text{ ms}$$

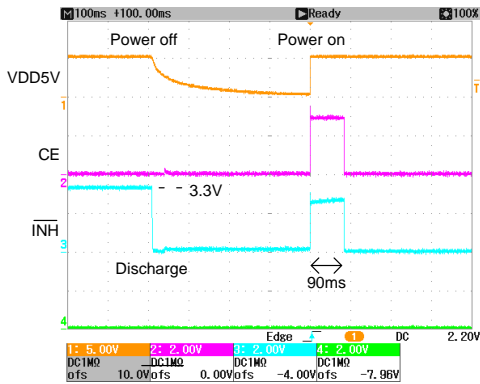

Figure 16. $\overline{\text{INH}}$ Signal Pulse Just After the Power Supply (FPGA Output)

The input high level of the $\overline{\text{INH}}$ signal input into an LCD driver IC is shown in the following equations.

$$V_{IH} = \frac{R_{31}}{R_{26} + R_{31}} \times V_{\text{OFFPGA}} = \frac{100}{30 + 100} \times 3.3 = 2.54 \text{ V}$$

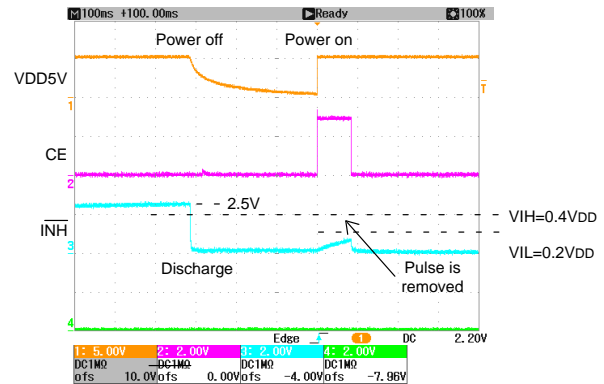

Figure 17. $\overline{\text{INH}}$ Signal Pulse Just After the Power Supply (LCD Driver IC Input)

ABOUT THE PERIPHERAL CIRCUITS OF THE CCB SERIAL DATA SIGNALS (CE, CL, DI)

The resistors from R27 to R29 are the dumping resistance for waveform shaping. In addition, when waveform shaping is more necessary, connect a condenser (for example, from

100 to 1000 pF) to [C]. The resistors from R32 to R34 are pull-down resistor to protect a circuit when a jump socket was removed.

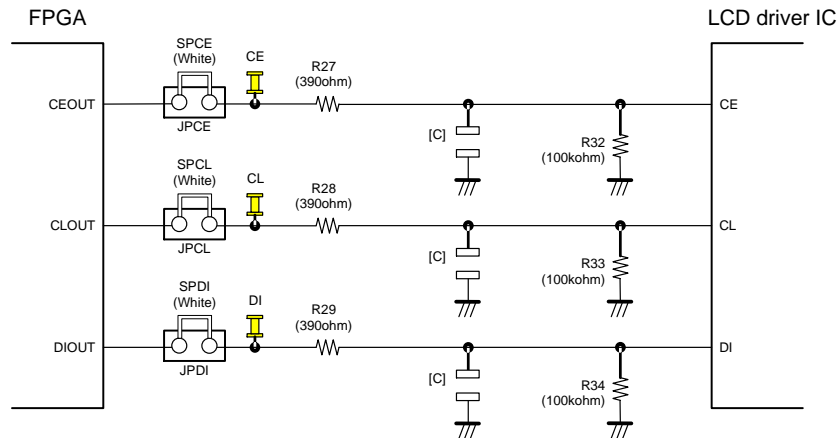

Figure 18. Peripheral Circuit of the CCB Serial Data Transfer Signal

LC75843UGAGEVB

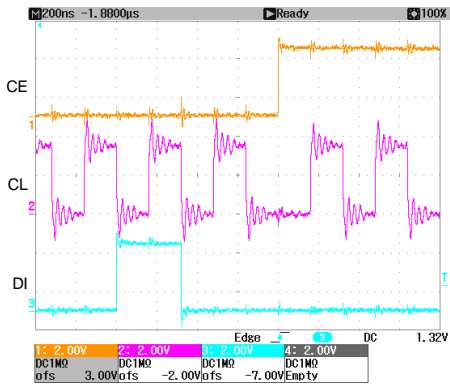

Figure 19. CCB Serial Data Signal (FPGA Output)

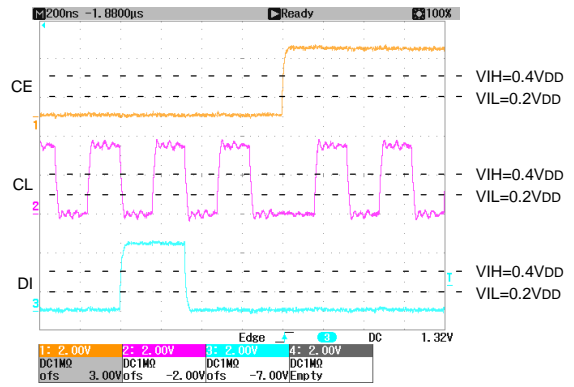

Figure 20. CCB Serial Data Signal (LCD Driver IC Input)

LCD PANEL SEGMENT ALLOTMENT

The LCD panel circuit of this evaluation board uses a socket pin, and LCD panel made in varitronix is inserted there. The specifications of the LCD panel are four common pins, 32 segment pins, twisted nematic (TN) type, reflection type, alphanumeric character display and 70.00 mm × 25.00 mm × 2.80 mm.

Four common output signals and 21 segment output signals of the LCD driver IC are connected to an LCD panel.

Because S28 output is connected to twelve segments of the LCD panel, the customer can confirm the waveform of big load.

The following figure and table shows the segment allotment of the 1/4 duty drive LCD panel.

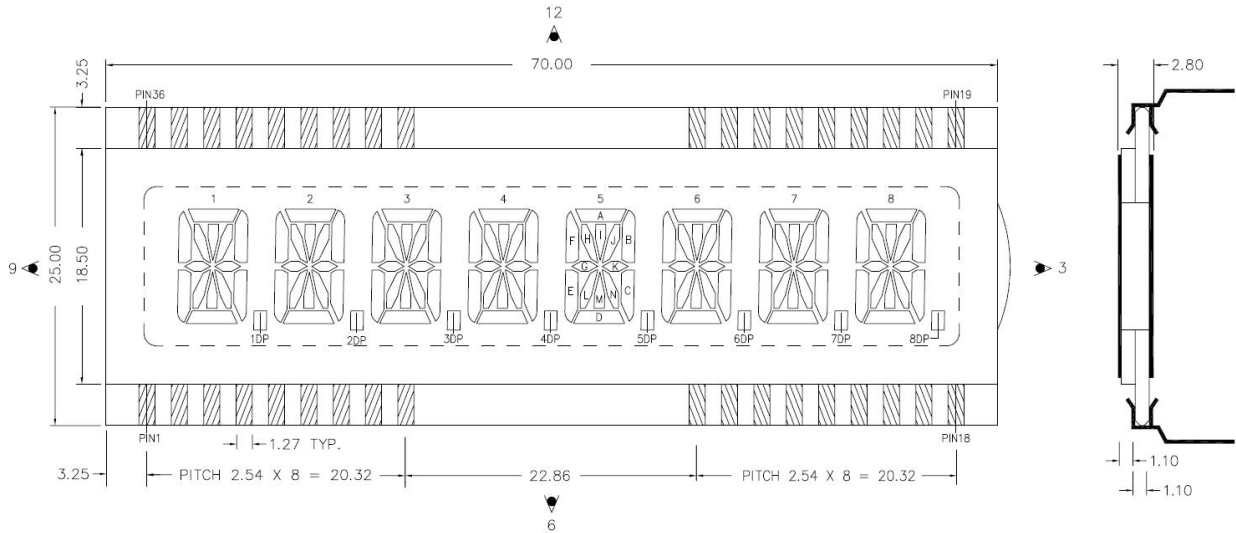

Figure 21. Segment Allotment of the LCD Panel

LC75843UGAGEVB

Table 14. RELATIONS BETWEEN THE LCD PANEL AND THE LCD DRIVER IC

Pin No.	LCD Panel				LCD Driver IC (When the 1/4 Duty Drive Is Set)				
	COM3	COM2	COM1	COM0	Connection Pin	COM4	COM3	COM2	COM1
1	COM3	-	-	-	COM4/S25	-	-	-	-
2	1D	1E	1F	-	S28	D100	D99	D98	D97
3	1N	1K	1J	1I	S28	D100	D99	D98	D97
4	2D	2E	2F	-	S28	D100	D99	D98	D97
5	2N	2K	2J	2I	S28	D100	D99	D98	D97
6	3D	3E	3F	-	S28	D100	D99	D98	D97
7	3N	3K	3J	3I	S28	D100	D99	D98	D97
8	4D	4E	4F	-	S5	D20	D19	D18	D17
9	4N	4K	4J	4I	S6	D24	D23	D22	D21
10	5D	5E	5F	-	S7	D28	D27	D26	D25
11	5N	5K	5J	5I	S8	D32	D31	D30	D29
12	6D	6E	6F	-	S9	D36	D35	D34	D33
13	6N	6K	6J	6I	S10	D40	D39	D38	D37
14	7D	7E	7F	-	S11	D44	D43	D42	D41
15	7N	7K	7J	7I	S12	D48	D47	D46	D45
16	8D	8E	8F	-	S13	D52	D51	D50	D49
17	8N	8K	8J	8I	S14	D56	D55	D54	D53
18	-	COM2	-	-	COM3/S26	-	-	-	-
19	-	-	-	COM0	COM1	-	-	-	-
20	8DP	8C	8B	8A	S24	D96	D95	D94	D93
21	8M	8L	8G	8H	S23	D92	D91	D90	D89
22	7DP	7C	7B	7A	S22	D88	D87	D86	D85
23	7M	7L	7G	7H	S21	D84	D83	D82	D81
24	6DP	6C	6B	6A	S20	D80	D79	D78	D77
25	6M	6L	6G	6H	S19	D76	D75	D74	D73
26	5DP	5C	5B	5A	S18	D72	D71	D70	D69
27	5M	5L	5G	5H	S17	D68	D67	D66	D65
28	4DP	4C	4B	4A	S16	D64	D63	D62	D61
29	4M	4L	4G	4H	S15	D60	D59	D58	D57
30	3DP	3C	3B	3A	S28	D100	D99	D98	D97
31	3M	3L	3G	3H	S28	D100	D99	D98	D97
32	2DP	2C	2B	2A	S28	D100	D99	D98	D97
33	2M	2L	2G	2H	S28	D100	D99	D98	D97
34	1DP	1C	1B	1A	S28	D100	D99	D98	D97
35	1M	1L	1G	1H	S28	D100	D99	D98	D97
36	-	-	COM1	-	COM2/S27	-	-	-	-

LC75843UGAGEVB

TIMING OF THE CCB SERIAL DATA TRANSFER

When the 1/4 Duty Drive Mode Is Set

When the controller circuit in the evaluation board and the 1/4 duty LCD panel are used, remove the jump sockets of the

DT0 and DT1. The command transfer is the form that 1/4 duty drive mode and CL stop at low level.

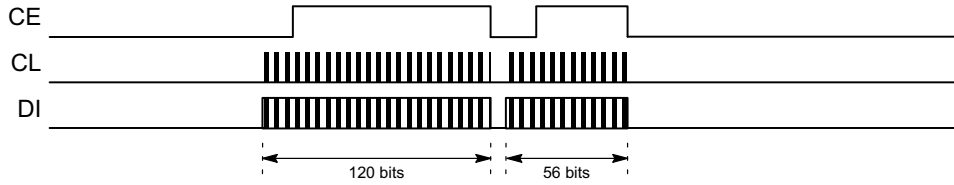

The following figure shows the allotment of each bit.

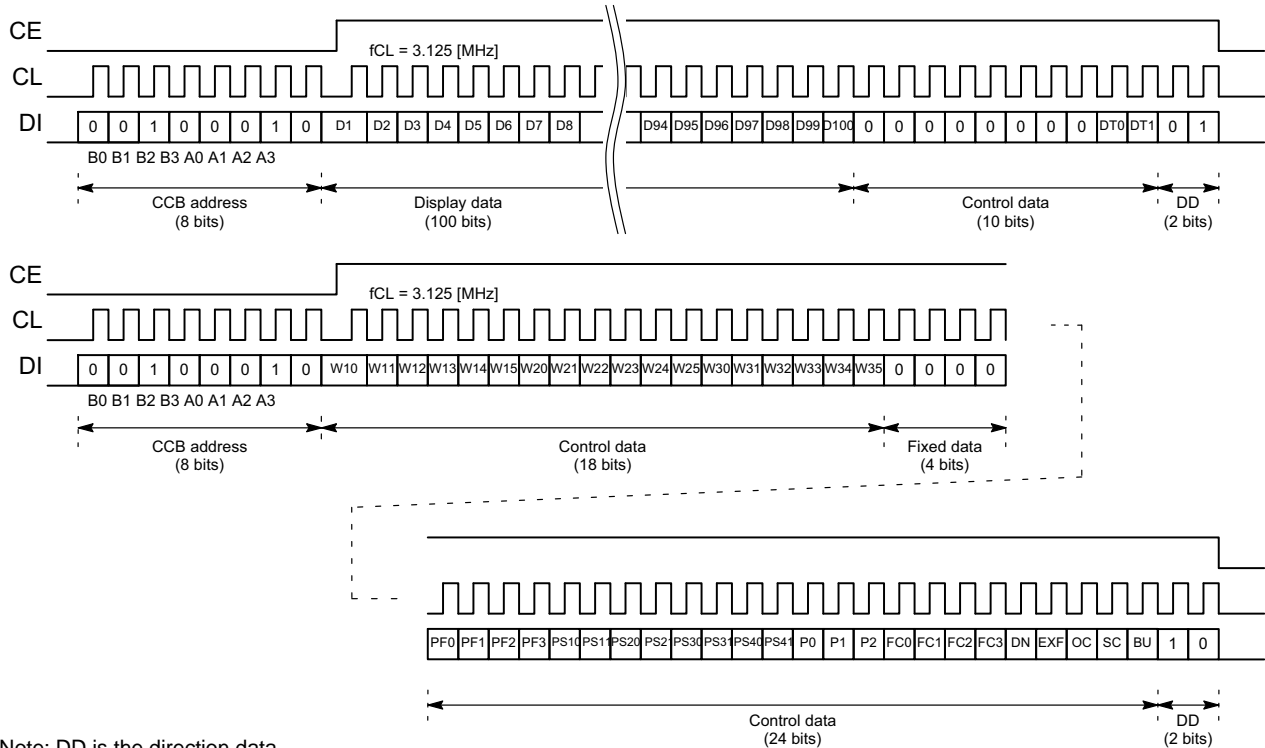

Note: DD is the direction data.

- CCB address : "44H"
- D1 to D100 : Display data.
- DT0, DT1 : LCD drive scheme (1/1 to 1/4 duty drive) setting control data. set by DT0 and DT1 jump sockets.
- W10 to W15 : PWM duty data for S2/P2(ch1). set by W0 to W5 switches.
- W20 to W25 : PWM duty data for S3/P3(ch2). set by W0 to W5 switches.
- W30 to W35 : PWM duty data for S4/P4(ch3). set by W0 to W5 switches.
- PF0 to PF3 : PWM output waveform frame frequency setting control data. set by PF0 to PF3 switches.
- PS10, PS11 : General-purpose output port (S1/P1) function setting control data. set by P1 switch.
- PS20, PS21 : General-purpose output port (S2/P2) function setting control data.
- PS30, PS31 : General-purpose output port (S3/P3) function setting control data.
- PS40, PS41 : General-purpose output port (S4/P4) function setting control data.
- P0 to P2 : Segment output port/general-purpose output port switching control data.
- FC0 to FC3 : Common/segment output waveform frame frequency setting control data. set by FC0 to FC3 switches.
- DN : The S28 pin state setting control data.
- EXF : External clock operating frequency setting control data. set by EXF switch.
- OC : Internal oscillator operating mode/external clock operating mode switching control data. set by OC switch.
- SC : On/off state of the segments control data. set by SC switch.
- BU : Normal mode/power-saving mode switching control data. set by BU switch.

LC75843UGAGEVB

When the 1/3 Duty Drive Mode Is Set

When the controller circuit in the evaluation board and the 1/3 duty LCD panel are used, insert the jump socket of the DT0 and remove the jump socket of the DT1. When the jump sockets of the DT0 and DT1 were set for the setting that was not 1/4 duty drive, the “DEMO mode” can use only a mode

of “0”, “1”, “4” and “5”. In addition, when “DEMO mode” was set to “2”, “3”, “6”, “7”, “8” and “9”, the controller is ignored without operating. The command transfer is the form that 1/3 duty drive mode and CL stop at low level.

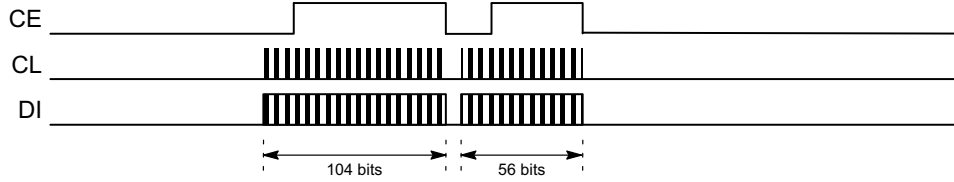

The following figure shows the allotment of each bit.

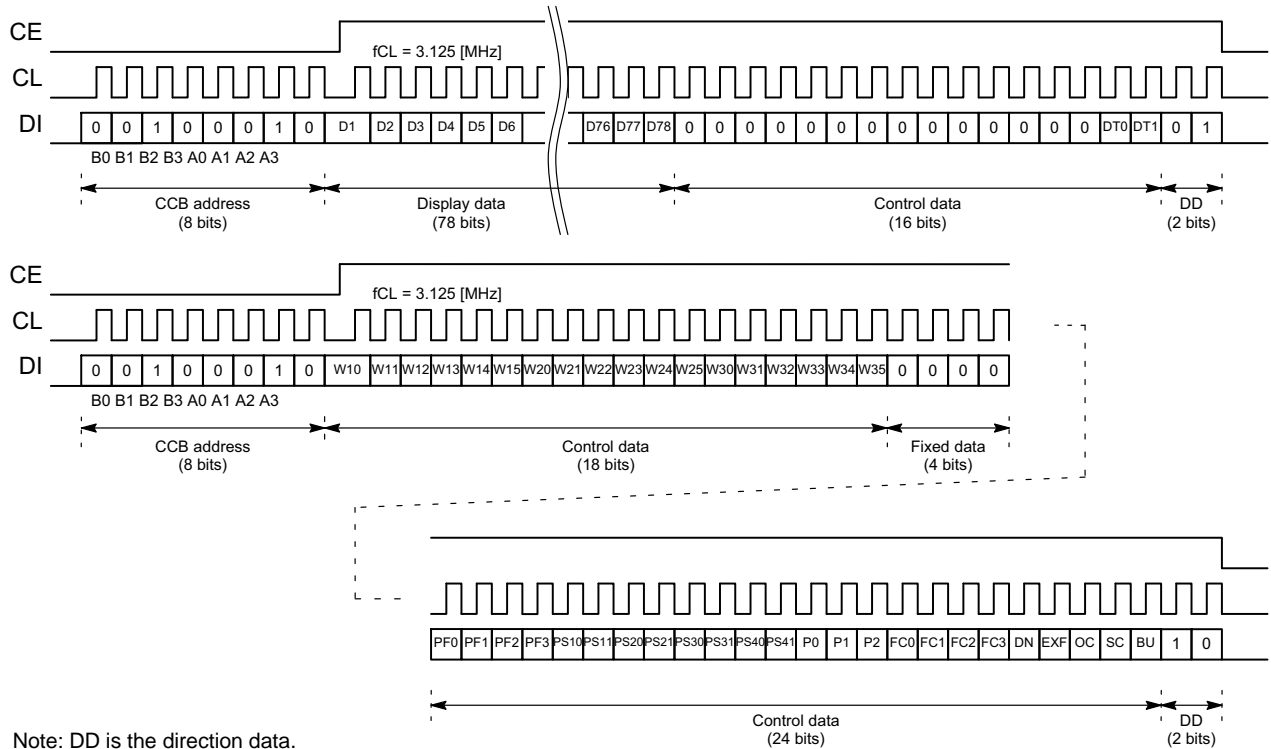

Note: DD is the direction data.

- CCB address : “44H”
- D1 to D78 : Display data.
- DT0, DT1 : LCD drive scheme (1/1 to 1/4 duty drive) setting control data. set by DT0 and DT1 jump sockets.
- W10 to W15 : PWM duty data for S2/P2(ch1). set by W0 to W5 switches.
- W20 to W25 : PWM duty data for S3/P3(ch2). set by W0 to W5 switches.
- W30 to W35 : PWM duty data for S4/P4(ch3). set by W0 to W5 switches.
- PF0 to PF3 : PWM output waveform frame frequency setting control data. set by PF0 to PF3 switches.
- PS10, PS11 : General-purpose output port (S1/P1) function setting control data. set by P1 switch.
- PS20, PS21 : General-purpose output port (S2/P2) function setting control data.
- PS30, PS31 : General-purpose output port (S3/P3) function setting control data.
- PS40, PS41 : General-purpose output port (S4/P4) function setting control data.
- P0 to P2 : Segment output port/general-purpose output port switching control data.
- FC0 to FC3 : Common/segment output waveform frame frequency setting control data. set by FC0 to FC3 switches.
- DN : The S28 pin state setting control data.
- EXF : External clock operating frequency setting control data. set by EXF switch.
- OC : Internal oscillator operating mode/external clock operating mode switching control data. set by OC switch.
- SC : On/off state of the segments control data. set by SC switch.
- BU : Normal mode/power-saving mode switching control data. set by BU switch.

LC75843UGAGEVB

When the 1/2 Duty Drive Mode Is Set

When the controller circuit in the evaluation board and the 1/2 duty LCD panel are used, insert the jump socket of the DT1 and remove the jump socket of the DT0. When the jump sockets of the DT0 and DT1 were set for the setting that was not 1/4 duty drive, the “DEMO mode” can use only a mode

of “0”, “1”, “4” and “5”. In addition, when “DEMO mode” was set to “2”, “3”, “6”, “7”, “8” and “9”, the controller is ignored without operating. The command transfer is the form that 1/2 duty drive mode and CL stop at low level.

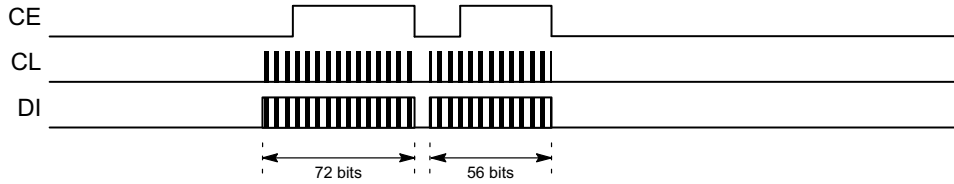

The following figure shows the allotment of each bit.

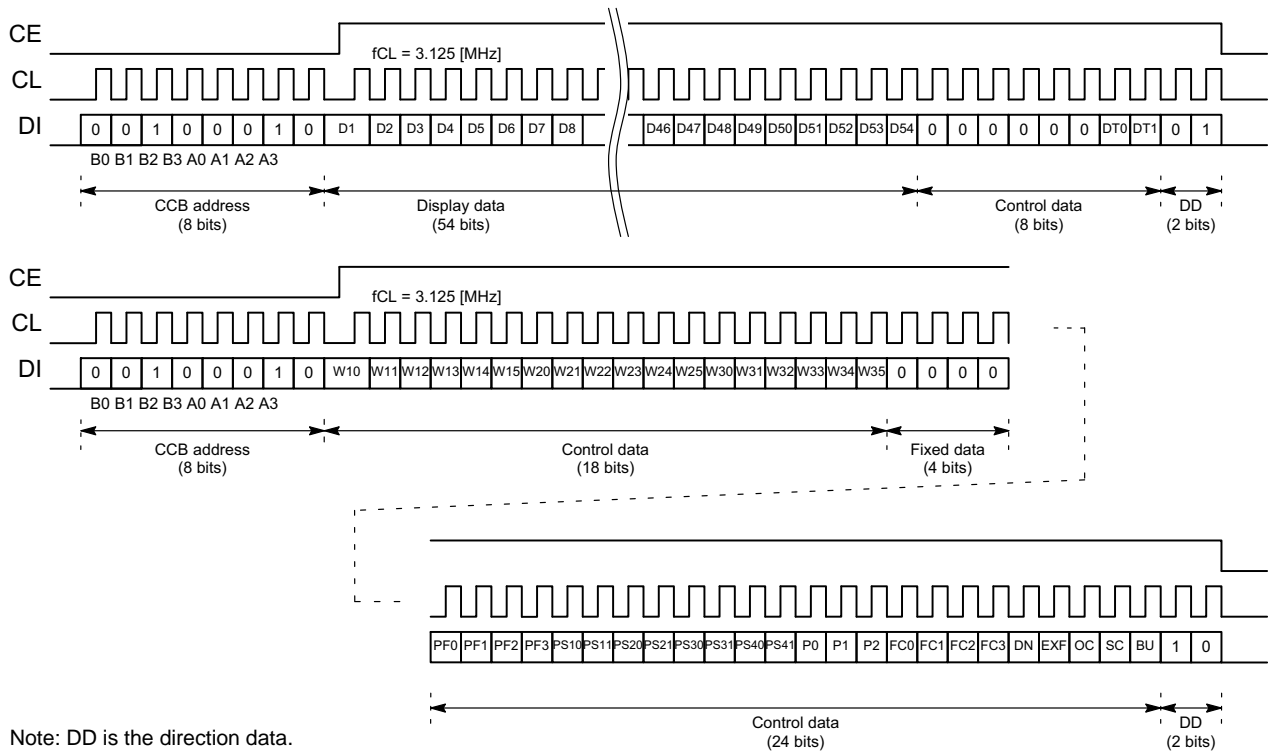

- CCB address : “44H”
- D1 to D54 : Display data.
- DT0, DT1 : LCD drive scheme (1/1 to 1/4 duty drive) setting control data. set by DT0 and DT1 jump sockets.
- W10 to W15 : PWM duty data for S2/P2(ch1). set by W0 to W5 switches.
- W20 to W25 : PWM duty data for S3/P3(ch2). set by W0 to W5 switches.
- W30 to W35 : PWM duty data for S4/P4(ch3). set by W0 to W5 switches.
- PF0 to PF3 : PWM output waveform frame frequency setting control data. set by PF0 to PF3 switches.
- PS10, PS11 : General-purpose output port (S1/P1) function setting control data. set by P1 switch.
- PS20, PS21 : General-purpose output port (S2/P2) function setting control data.
- PS30, PS31 : General-purpose output port (S3/P3) function setting control data.
- PS40, PS41 : General-purpose output port (S4/P4) function setting control data.
- P0 to P2 : Segment output port/general-purpose output port switching control data.
- FC0 to FC3 : Common/segment output waveform frame frequency setting control data. set by FC0 to FC3 switches.
- DN : The S28 pin state setting control data.
- EXF : External clock operating frequency setting control data. set by EXF switch.
- OC : Internal oscillator operating mode/external clock operating mode switching control data. set by OC switch.
- SC : On/off state of the segments control data. set by SC switch.
- BU : Normal mode/power-saving mode switching control data. set by BU switch.

LC75843UGAGEVB

When the Static (1/1 Duty) Drive Mode Is Set

When the controller circuit in the evaluation board and the static (1/1 duty) LCD panel are used, insert the jump sockets of the DT0 and DT1. When the jump sockets of the DT0 and DT1 were set for the setting that was not 1/4 duty drive, the “DEMO mode” can use only a mode of “0”, “1”, “4” and “5”.

In addition, when “DEMO mode” was set to “2”, “3”, “6”, “7”, “8” and “9”, the controller is ignored without operating. The command transfer is the form that static (1/1 duty) drive mode and CL stop at low level.

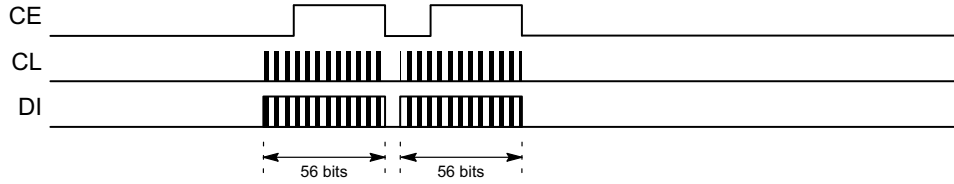

The following figure shows the allotment of each bit.

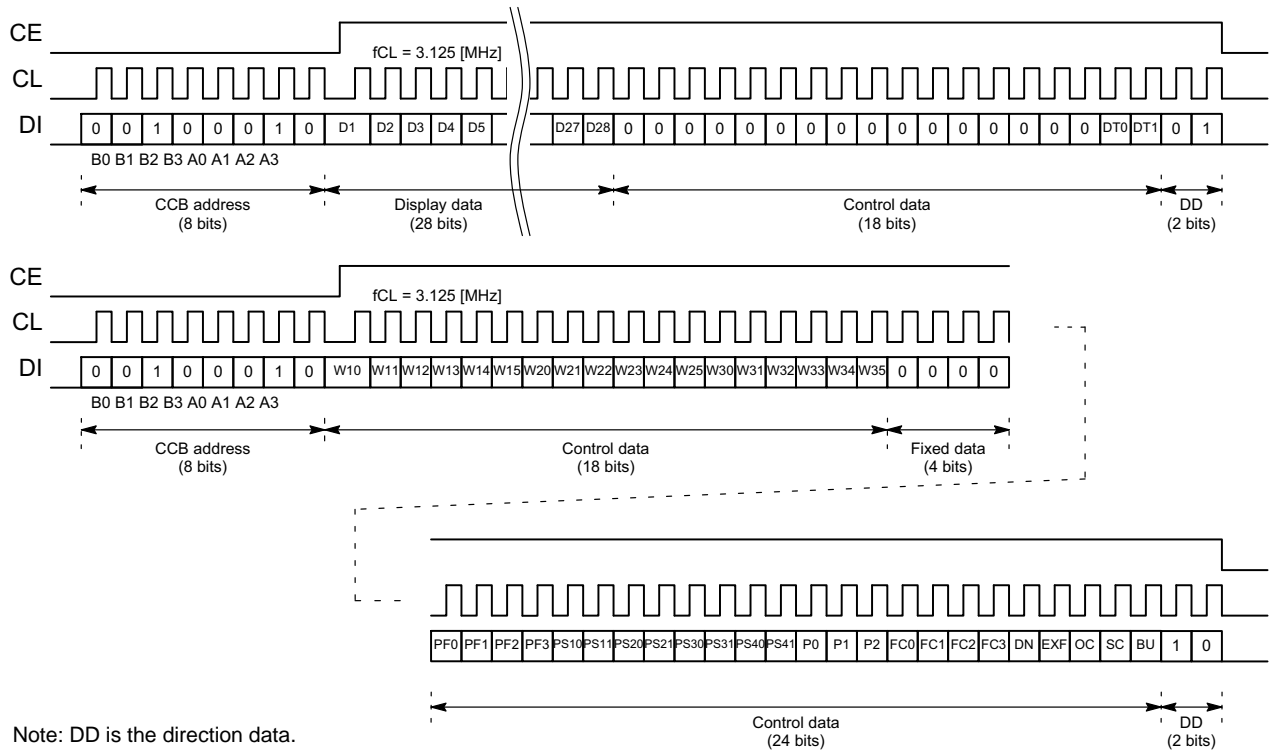

- CCB address : “44H”
- D1 to D28 : Display data.
- DT0, DT1 : LCD drive scheme (1/1 to 1/4 duty drive) setting control data. set by DT0 and DT1 jump sockets.
- W10 to W15 : PWM duty data for S2/P2(ch1). set by W0 to W5 switches.
- W20 to W25 : PWM duty data for S3/P3(ch2). set by W0 to W5 switches.
- W30 to W35 : PWM duty data for S4/P4(ch3). set by W0 to W5 switches.
- PF0 to PF3 : PWM output waveform frame frequency setting control data. set by PF0 to PF3 switches.
- PS10, PS11 : General-purpose output port (S1/P1) function setting control data. set by P1 switch.
- PS20, PS21 : General-purpose output port (S2/P2) function setting control data.
- PS30, PS31 : General-purpose output port (S3/P3) function setting control data.
- PS40, PS41 : General-purpose output port (S4/P4) function setting control data.
- P0 to P2 : Segment output port/general-purpose output port switching control data.
- FC0 to FC3 : Common/segment output waveform frame frequency setting control data. set by FC0 to FC3 switches.
- DN : The S28 pin state setting control data.
- EXF : External clock operating frequency setting control data. set by EXF switch.
- OC : Internal oscillator operating mode/external clock operating mode switching control data. set by OC switch.
- SC : On/off state of the segments control data. set by SC switch.
- BU : Normal mode/power-saving mode switching control data. set by BU switch.

LC75843UGAGEVB

DEMONSTRATION TIMING CHART

All OFF Test Mode Timing (DEMO Mode = "0")

When demonstration mode is "0", all LCD segments and all LED are off. The customer can confirm off drive waveform outputting from the LCD driver IC. About the

example of the waveform which can confirm, refer to "Oscilloscope Observation Waveform".

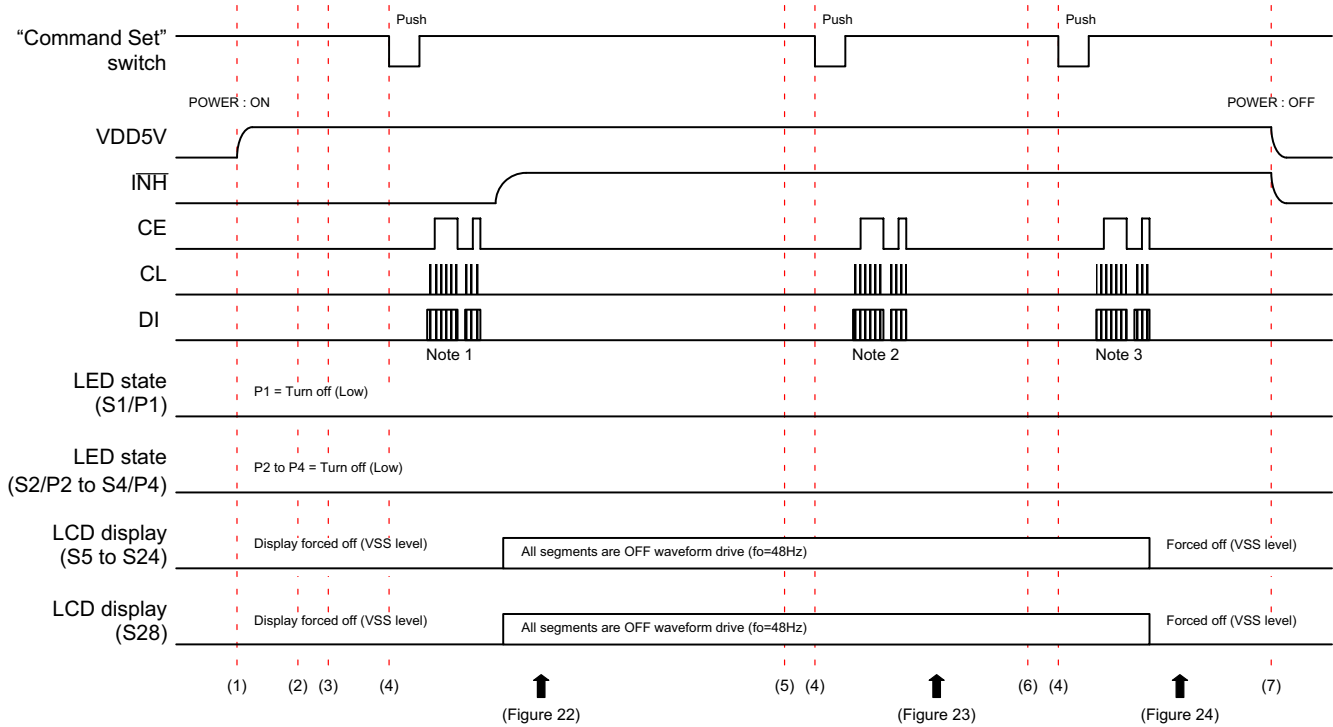

Operation Sequence

1. The power supply of the evaluation board is turned on by moving "POWER" switch to the "ON" position.
2. The evaluation mode is selected by moving "DEMO mode" switch to the "0" position.
3. Set the switches (PF0 to PF3, FC0 to FC3, P1, EXF, OC, SC and BU) to set control data. For example, when the PF0 to PF3="L(0), L(0), L(0), L(0)", FC0 to FC3="L(0), L(0), L(0), L(0)", P1="L(0)", EXF="L(0)", OC="L(0)", SC="L(0)" and BU="L(0)" are set.
4. The CCB serial data are transferred from a controller circuit to LCD driver IC by pushing the switch of "Command Set".
5. Set the switches of SC="H(1)" and BU="L(0)".
6. Set the switches of SC="L(0)" and BU="H(1)".
7. The power supply of the evaluation board is turned off by moving "POWER" switch to the "OFF" position.

Transfer Command Data

Note 1: D1=set by the switch of P1 to "0", D2 to D100= all "0" data, DT0="0", DT1="0", PF0 to PF3="0,0,0,0", FC0 to FC3="0,0,0,0", W10 to W15="0,0,0,0,0,0", W20 to W25="0,0,0,0,0,0", W30 to W35="0,0,0,0,0,0", PS10="0", PS11="0", PS20="0", PS21="0", PS30="0", PS31="0", PS40="0", PS41="0", P0 to P2="1,0,0", DN="1", EXF="0", OC="0", SC="0", BU="0". The following figure shows the LCD display contents.

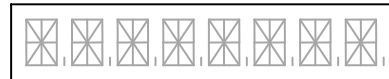

Note 2: SC="1", BU="0", others is set the same value.

Note 3: SC="0", BU="1", others is set the same value.

LC75843UGAGEVB

All ON Test Mode Timing (DEMO Mode = "1")

When demonstration mode is "1", all LCD segments and all LED are on. The customer can confirm off drive waveform outputting from the LCD driver IC. About the

example of the waveform which can confirm, refer to "Oscilloscope Observation Waveform".

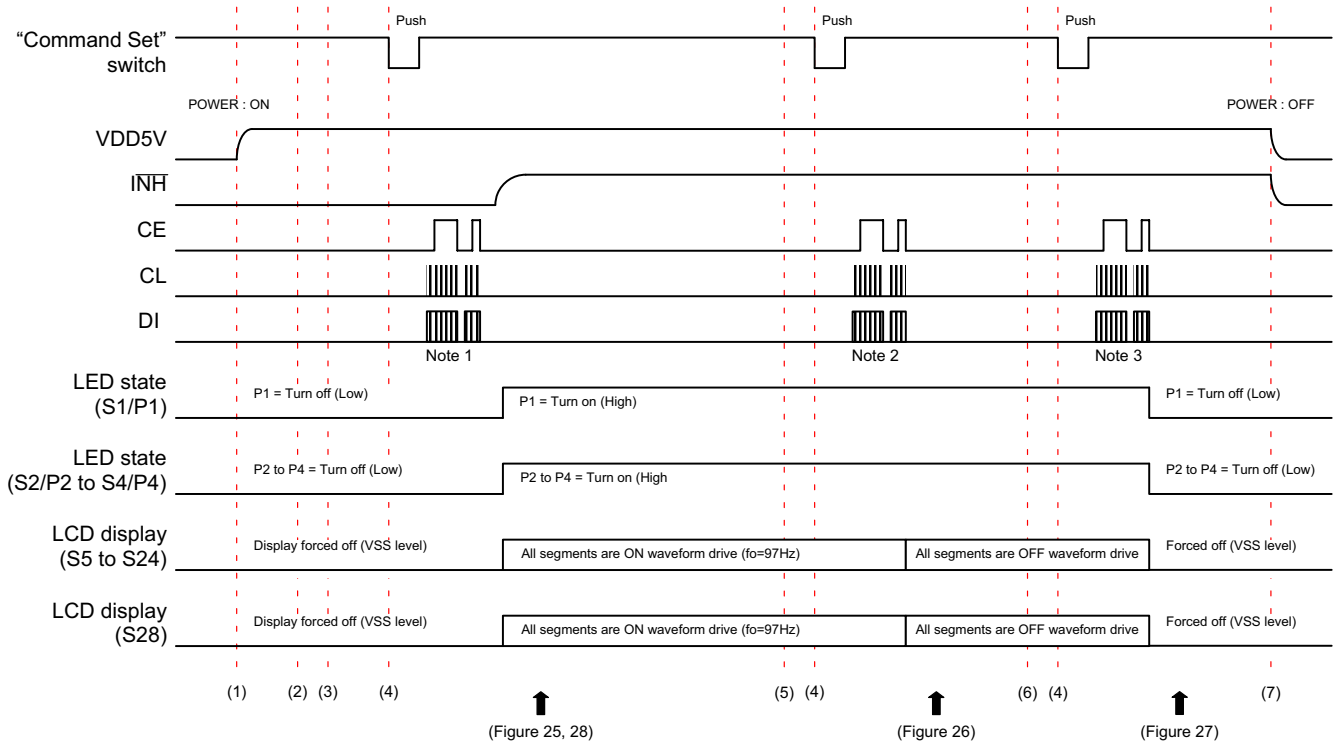

Operation Sequence

1. The power supply of the evaluation board is turned on by moving "POWER" switch to the "ON" position.
2. The evaluation mode is selected by moving "DEMO mode" switch to the "1" position.
3. Set the switches (PF0 to PF3, FC0 to FC3, P1, EXF, OC, SC and BU) to set control data. For example, when the PF0 to PF3="L(0), L(0), L(0), L(0)", FC0 to FC3="L(0), H(1), L(0), H(1)", P1="H(1)", EXF="L(0)", OC="L(0)", SC="L(0)" and BU="L(0)" are set.
4. The CCB serial data are transferred from a controller circuit to LCD driver IC by pushing the switch of "Command Set".
5. Set the switches of SC="H(1)" and BU="L(0)".
6. Set the switches of SC="L(0)" and BU="H(1)".
7. The power supply of the evaluation board is turned off by moving "POWER" switch to the "OFF" position.

Transfer Command Data

Note 1: D1=set by the switch of P1 to "1", D2 to D100= all "1" data, DT0="0", DT1="0", PF0 to PF3="0,0,0,0", FC0 to FC3="0,0,0,0", W10 to W15="0,0,0,0,0,0", W20 to W25="0,0,0,0,0,0", W30 to W35="0,0,0,0,0,0", PS10="0", PS11="0", PS20="0", PS21="0", PS30="0", PS31="0", PS40="0", PS41="0", P0 to P2="1,0,0", DN="1", EXF="0", OC="0", SC="0", BU="0". The following figure shows the LCD display contents.



- Note 2: SC="1", BU="0", others is set the same value.
 Note 3: SC="0", BU="1", others is set the same value.

LC75843UGAGEVB

LCD Display Test (1) Mode Timing (DEMO Mode = "2")

When demonstration mode is "2", LCD number display and the LED are all off. The customer can confirm on/off drive waveform outputting from the LCD driver IC. Because S28 output is connected to twelve segments, the

customer can confirm the waveform of big load. About the example of the waveform which can confirm, refer to "Oscilloscope Observation Waveform".

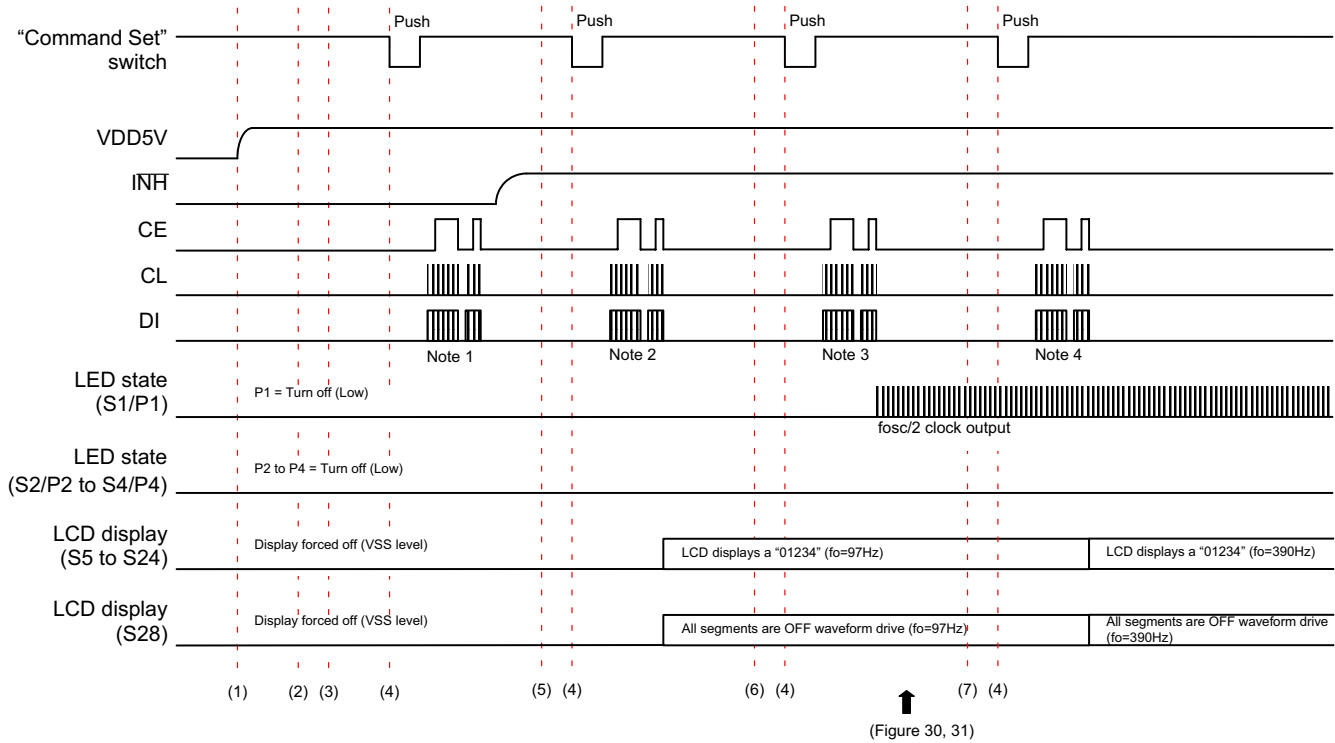

(Figure 30, 31)

Operation Sequence

1. The power supply of the evaluation board is turned on by moving "POWER" switch to the "ON" position.
2. The evaluation mode is selected by moving "DEMO mode" switch to the "2" position.
3. Set the switches (PF0 to PF3, FC0 to FC3, P1, EXF, OC, SC and BU) to set control data. For example, when the PF0 to PF3="L(0), L(0), L(0), L(0)", FC0 to FC3="L(0), H(1), L(0), H(1)", P1="L(0)", EXF="L(0)", OC="L(0)", SC="L(0)" and BU="H(1)" are set.
4. The CCB serial data are transferred from a controller circuit to LCD driver IC by pushing the switch of "Command Set".
5. Set the switches of SC="L(0)" and BU="L(0)".
6. Set the switch of P1="H(1)".
7. Set the switches of FC0 to FC3="H(1), H(1), H(1), H(1)".

Transfer Command Data

Note 1: D1="0", D2 to D16= all "0" data, D17 to D96= "01234" display data, D97 to D100= all "0" data, DT0="0", DT1="0", PF0 to PF3="0,0,0,0", FC0 to FC3="0,1,0,1", W10 to W15="0,0,0,0,0,0", W20 to W25="0,0,0,0,0,0", W30 to W35="0,0,0,0,0,0", PS10="0", PS11="0", PS20="0", PS21="0", PS30="0", PS31="0", PS40="0", PS41="0", P0 to P2="1,0,0", DN="1", EXF="0", OC="0", SC="0", BU="1".

Note 2: BU="0", others is set the same value. "01234" display data is D[96:17] = 0110 0010 0111 0010 0011 0010 0110 0000 0111 0000 0100 0010 0100 1000 0100 1100 0000 0000 0000 1110.

The following figure shows the LCD display contents.

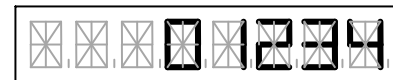

Note 3: D1="0", PS10 and PS11=set by the switch of P1 to "1,0", others is set the same value.

Note 4: FC0 to FC3="1,1,1,1", others is set the same value.

LC75843UGAGEVB

LCD Display Test (2) Mode Timing (DEMO Mode = "3")

When demonstration mode is "3", LCD alphabet display and the LED are all off. The customer can confirm on/off drive waveform outputting from the LCD driver IC. Because S28 output is connected to twelve segments, the

customer can confirm the waveform of big load. About the example of the waveform which can confirm, refer to "Oscilloscope Observation Waveform".

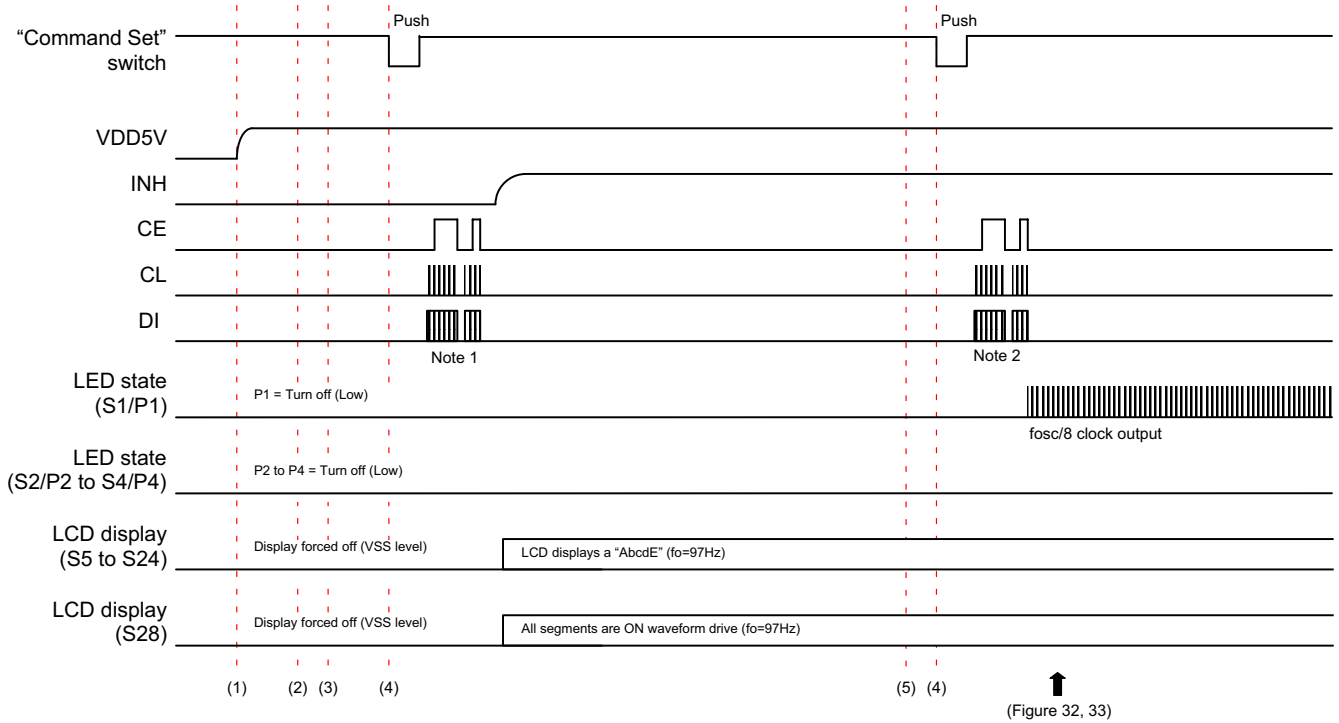

Operation Sequence

1. The power supply of the evaluation board is turned on by moving "POWER" switch to the "ON" position.
2. The evaluation mode is selected by moving "DEMO mode" switch to the "3" position.
3. Set the switches (PF0 to PF3, FC0 to FC3, P1, EXF, OC, SC and BU) to set control data. For example, when the PF0 to PF3="L(0), L(0), L(0), L(0)", FC0 to FC3="L(0), H(1), L(0), H(1)", P1="L(0)", EXF="L(0)", OC="L(0)", SC="L(0)" and BU="L(0)" are set.
4. The CCB serial data are transferred from a controller circuit to LCD driver IC by pushing the switch of "Command Set".
5. Set the switch of P1="H(1)".

Transfer Command Data

Note 1: D1="0", D2 to D16= all "0" data, D17 to D96= "AbcdE" display data, D97 to D100= all "1" data, DT0="0", DT1="0", PF0 to PF3="0,0,0,0", FC0 to FC3="0,1,0,1", W10 to W15="0,0,0,0,0,0", W20 to W25="0,0,0,0,0,0", W30 to W35="0,0,0,0,0,0", PS10="0", PS11="0", PS20="0", PS21="0", PS30="0", PS31="0", PS40="0", PS41="0", P0 to P2="1,0,0", DN="1", EXF="0", OC="0", SC="0", BU="0".

"AbcdE" display data is D[96:17] = 0001 0010 0110 0010 0000 0010 0100 0010 0111 0010 0100 1110 0100 1100 0100 1100 0100 1110 0100 0110. The following figure shows the LCD display contents.

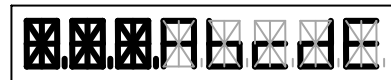

Note 2: D1="0", PS10 and PS11= set by the switch of P1 to "0,1", others is set the same value.

LC75843UGAGEVB

Segment Test Mode Timing (DEMO Mode = "4")

When demonstration mode is "4", the segment of the LCD displays on in turn whenever the customer pushes the switch

of "Command Set". The customer can confirm on/off drive waveform outputting from the LCD driver IC.

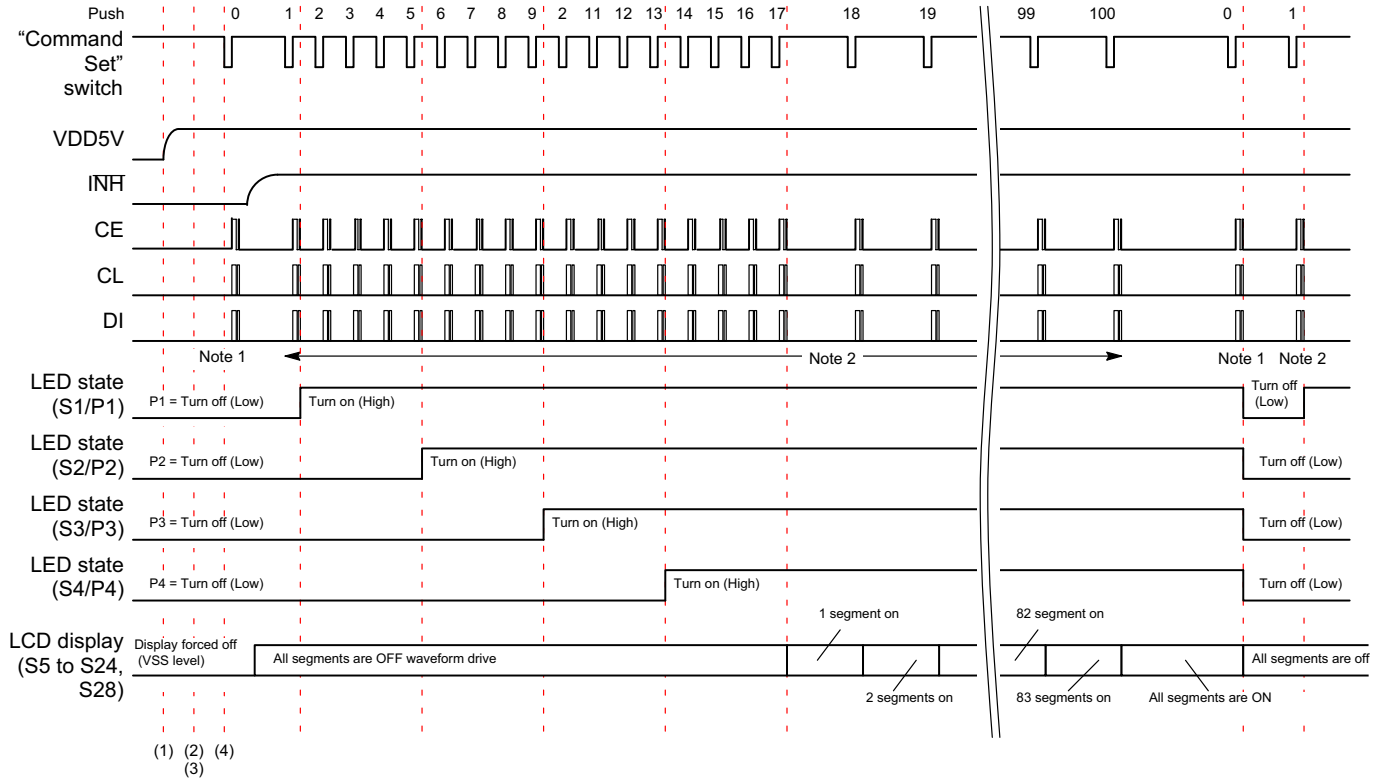

Operation Sequence

1. The power supply of the evaluation board is turned on by moving "POWER" switch to the "ON" position.
2. The evaluation mode is selected by moving "DEMO mode" switch to the "4" position.
3. Set the switches (PF0 to PF3, FC0 to FC3, P1, EXF, OC, SC and BU) to set control data. For example, when the PF0 to PF3="L(0), L(0), L(0), L(0)", FC0 to FC3="L(0), H(1), L(0), H(1)", P1="L(0)", EXF="L(0)", OC="L(0)", SC="L(0)" and BU="L(0)" are set.
4. The CCB serial data are transferred from a controller circuit to LCD driver IC by pushing the switch of "Command Set".

Transfer Command Data

- Note 1: D1 to D100= all "0" data,
 DT0="0", DT1="0", PF0 to PF3="0,0,0,0",
 FC0 to FC3="0,1,0,1",
 W10 to W15="0,0,0,0,0,0", W20 to
 W25="0,0,0,0,0,0", W30 to W35="0,0,0,0,0,0",
 PS10="0", PS11="0", PS20="0", PS21="0",
 PS30="0", PS31="0", PS40="0", PS41="0",
 P0 to P2="1,0,0",
 DN="1", EXF="0", OC="0", SC="0", BU="0".
- Note 2: The display data which made "1" in turn from D1 to D100 are transferred whenever the customer pushes the switch of "Command Set".
- When "Push 1": D1="1", D2 to D100= all "0" data.
 - When "Push 2": D1,D2="1,1", D3 to D100= all "0" data.
 - When "Push 3": D1,D2,D3="1,1,1", D4 to D100= all "0" data.
 - :
 - When "Push 17": D1 to D17= all "1" data, D18 to D100= all "0" data.
 - :
 - When "Push 99": D1 to D99= all "1" data, D100="0".
 - When "Push 100": D1 to D100= all "1" data.

LC75843UGAGEVB

Common Test Mode Timing (DEMO Mode = "5")

When demonstration mode is "5", LCD segment corresponding to same COM are all ON. Therefore, when COM1 is on, LED turn on the light. The customer can

confirm on/off drive waveform outputting from the LCD driver IC.

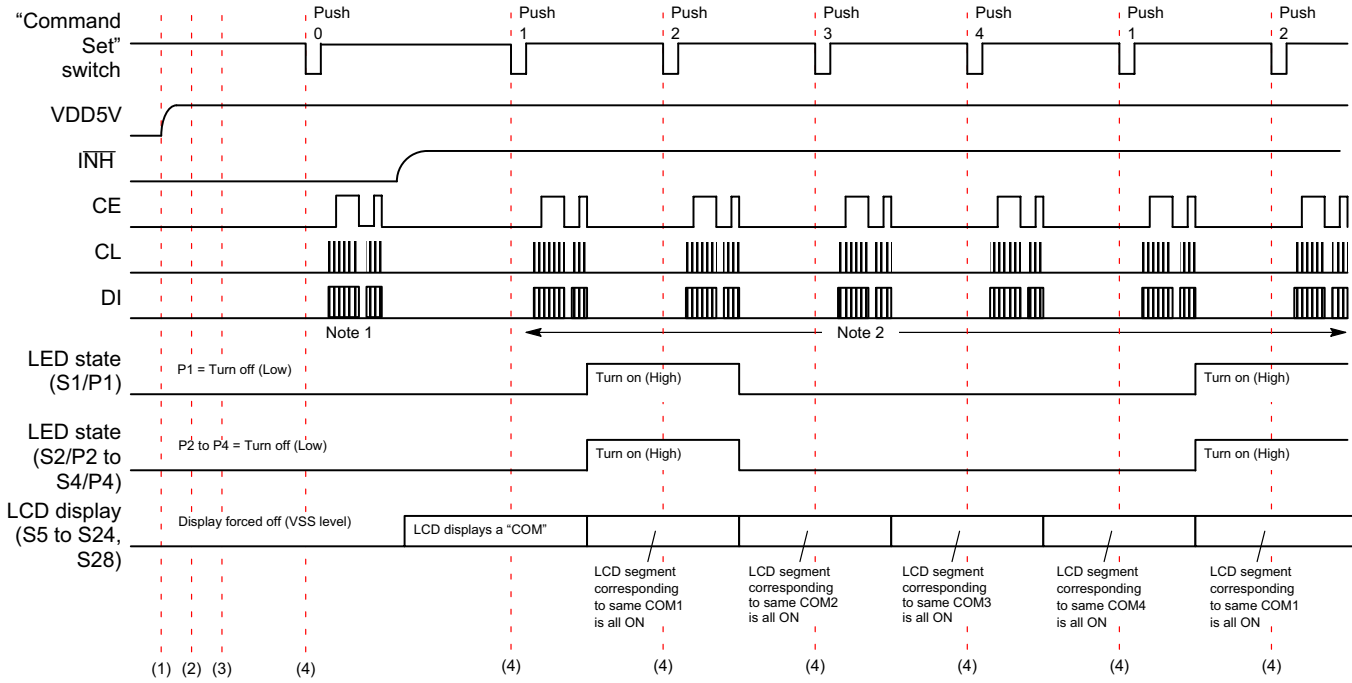

Operation Sequence

1. The power supply of the evaluation board is turned on by moving "POWER" switch to the "ON" position.
2. The evaluation mode is selected by moving "DEMO mode" switch to the "5" position.
3. Set the switches (PF0 to PF3, FC0 to FC3, P1, EXF, OC, SC and BU) to set control data. For example, when the PF0 to PF3="L(0), L(0), L(0), L(0)", FC0 to FC3="L(0), H(1), L(0), H(1)", P1="L(0)", EXF="L(0)", OC="L(0)", SC="L(0)" and BU="L(0)" are set.
4. The CCB serial data are transferred from a controller circuit to LCD driver IC by pushing the switch of "Command Set".

Transfer Command Data

Note 1: D1 to D16= all "0" data, D17 to D96= "COM" display data, D97 to D100= all "0" data, DT0="0", DT1="0", PF0 to PF3="0,0,0,0", FC0 to FC3="0,1,0,1", W10 to W15="0,0,0,0,0,0", W20 to W25="0,0,0,0,0,0", W30 to W35="0,0,0,0,0,0", PS10="0", PS11="0", PS20="0", PS21="0", PS30="0", PS31="0", PS40="0", PS41="0", P0 to P2="1,0,0", DN="1", EXF="0", OC="0", SC="0", BU="0".

"COM" display data is D[96:17] = 0110 0001 0111 0000 0001 0000 0000 0000 0000 0000 0010 0110 0000 1110 0000 1110 0000 0000 0000 0000. The following figure shows the LCD display contents.



Note 2: The display data from D1 to D100 which turned on all the LCD segments according with same COM are transferred whenever the customer pushes the switch of "Command Send".

- When "Push 1": D1, D5, D9, D13, D17, D21, D25, D29, D33, D37, D41, D45, D49, D53, D57, D61, D65, D69, D73, D77, D81, D85, D89, D93, D97 = all "1" data, Other display data= all "0" data



- When "Push 2": D2, D6, D10, D14, D18, D22, D26, D30, D34, D38, D42, D46, D50, D54, D58, D62, D66, D70, D74, D78, D82, D86, D90, D94, D98 = all "1" data, Other display data = all "0" data



LC75843UGAGEVB

- When "Push 3": D3, D7, D11, D15, D19, D23, D27, D31, D35, D39, D43, D47, D51, D55, D59, D63, D67, D71, D75, D79, D83, D87, D91, D95, D99= all "1" data, Other display data = all "0" data



- When "Push 4": D4, D8, D12, D16, D20, D24, D28, D32, D36, D40, D44, D48, D52, D56, D60, D64, D68, D72, D76, D80, D84, D88, D92, D96, D100= all "1" data, Other display data = all "0" data



LED (PWM) Test (1) Mode Timing (DEMO Mode = "6")

When demonstration mode is "6", the PWM duty is selected by switches from W0 to W5. Then, S2/P2(ch1), S3/P3(ch2) and S4/P4(ch3) can set same duty. The customer

can confirm LED drive waveform outputting from the LCD driver IC. About the example of the waveform which can confirm, refer to "Oscilloscope Observation Waveform".

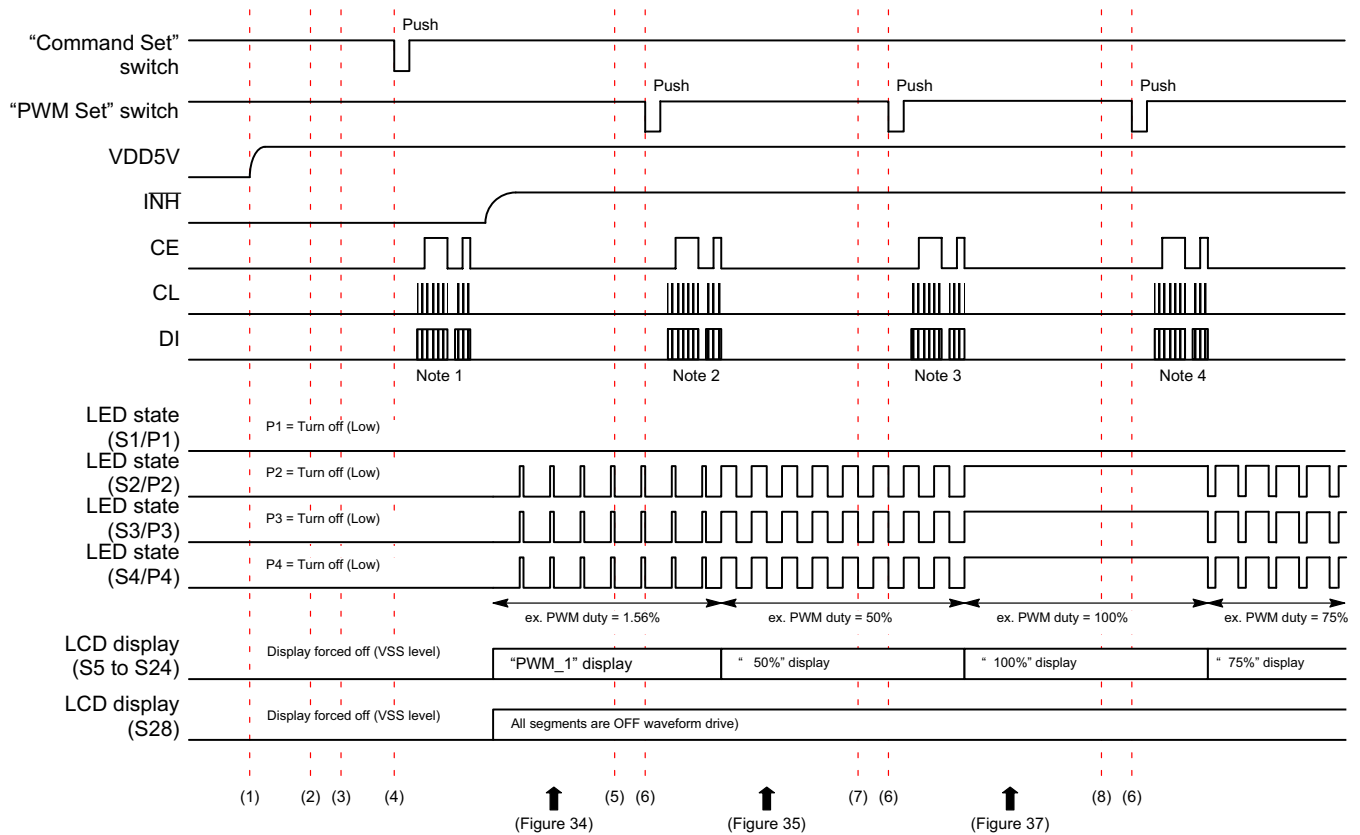

Operation Sequence

1. The power supply of the evaluation board is turned on by moving "POWER" switch to the "ON" position.
2. The evaluation mode is selected by moving "DEMO mode" switch to the "6" position.
3. Set the switches (PF0 to PF3, FC0 to FC3, P1, EXF, OC, SC, BU and W0 to W5) to set control data.
For example, when the PF0 to PF3="L(0), H(1), L(0), L(0)", FC0 to FC3="L(0), H(1), L(0), H(1)", P1="L(0)", EXF="L(0)", OC="L(0)", SC="L(0)", BU="L(0)" and W0 to W5="L(0), L(0), L(0), L(0), L(0), L(0)", are set.
4. The CCB serial data are transferred from a controller circuit to LCD driver IC by pushing the switch of "Command Set".
5. Set the switches of W0 to W5="H(1), H(1), H(1), H(1), H(1), L(0)".
6. The CCB serial data are transferred from a controller circuit to LCD driver IC by pushing the switch of "PWM Set".
7. Set the switches of W0 to W5="H(1), H(1), H(1), H(1), H(1), H(1)".
8. Set the switches of W0 to W5="H(1), H(1), H(1), H(1), L(0), H(1)".

LC75843UGAGEVB

Transfer Command Data

Note 1: D1 to D16= all "0" data,
 D17 to D96= "PWM_1" display data,
 D97 to D100= all "0" data, DT0="0", DT1="0",
 PF0 to PF3="0,1,0,0", FC0 to FC3="0,1,0,1",
 W10 to W15="0,0,0,0,0,0", W20 to
 W25="0,0,0,0,0,0", W30 to W35="0,0,0,0,0,0",
 PS10="1", PS11="1", PS20="1", PS21="0",
 PS30="0", PS31="1", PS40="1", PS41="1",
 P0 to P2="1,0,0",
 DN="1", EXF="0", OC="0", SC="0", BU="0".

"PWM_1" display data is D[96:17] = 0110 0000
 0000 0000 0110 0001 0110 0100 0011 0010
 0000 0000 0000 1000 0010 0110 1000 0110
 0100 0110.

The following figure shows the LCD display contents.



Note 2: D17 to D96= " 50%" display data,
 W10 to W15="1,1,1,1,1,0", W20 to
 W25="1,1,1,1,1,0", W30 to W35="1,1,1,1,1,0",
 others is set the same.
 The following figure shows the LCD display contents.



The PWM duty is
 displayed there.
 (1 to 100) Percent

Note 3: D17 to D96= "100%" display data,
 W10 to W15="1,1,1,1,1,1", W20 to
 W25="1,1,1,1,1,1", W30 to W35="1,1,1,1,1,1",
 others is set the same.

Note 4: D17 to D96= "75%" display data,
 W10 to W15="1,1,1,1,0,1", W20 to
 W25="1,1,1,1,0,1", W30 to W35="1,1,1,1,0,1",
 others is set the same.

LC75843UGAGEVB

LED (PWM) Test (2) Mode Timing (DEMO Mode = "7")

When demonstration mode is "7", the PWM duty is selected by switches from W0 to W5. The LCD driver IC (LC75843UGA) can control the PWM function of up to three channels separately. Therefore this evaluation board

divides RGB color LED into three groups. The customer can set duty of each group whenever the customer pushes the switch of "Command Set". The customer can confirm LED drive waveform outputting from the LCD driver IC.

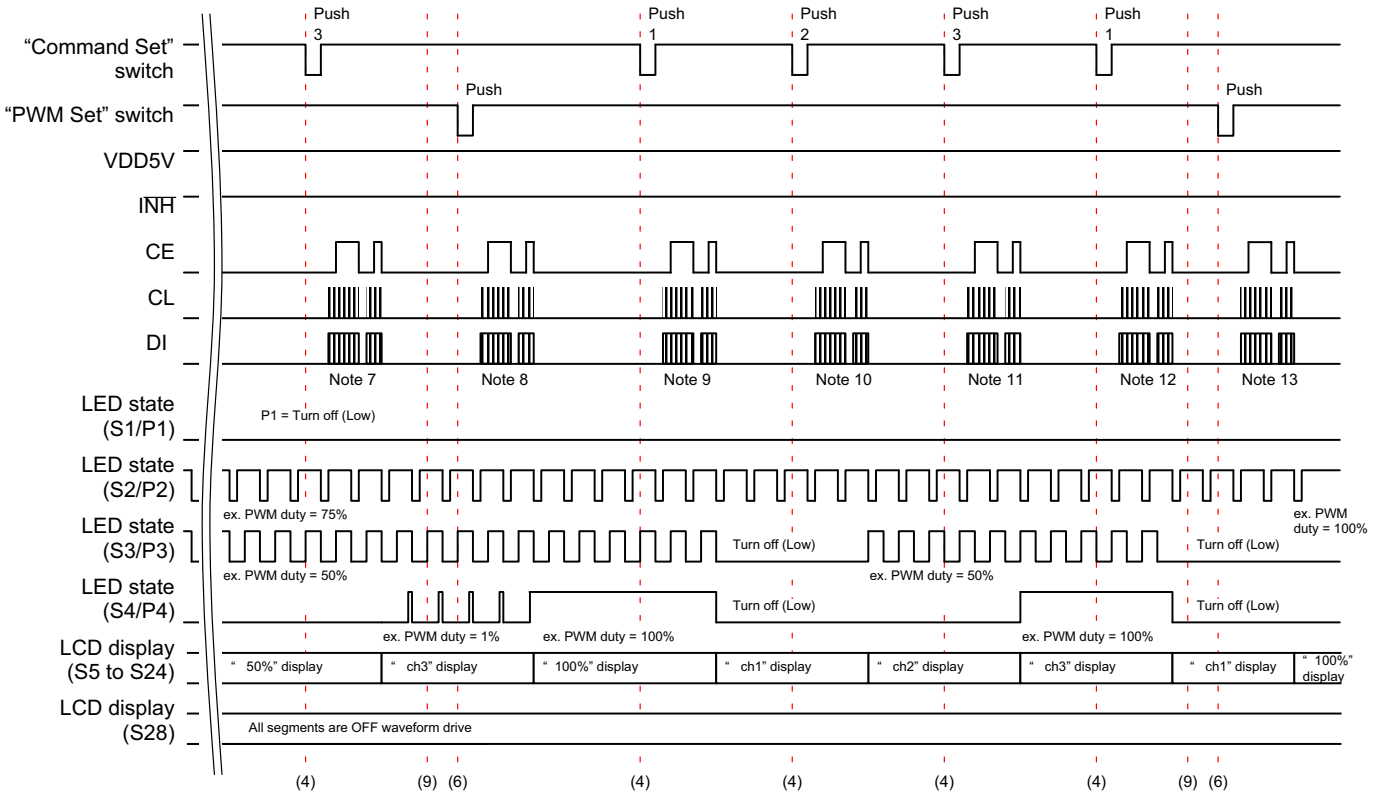
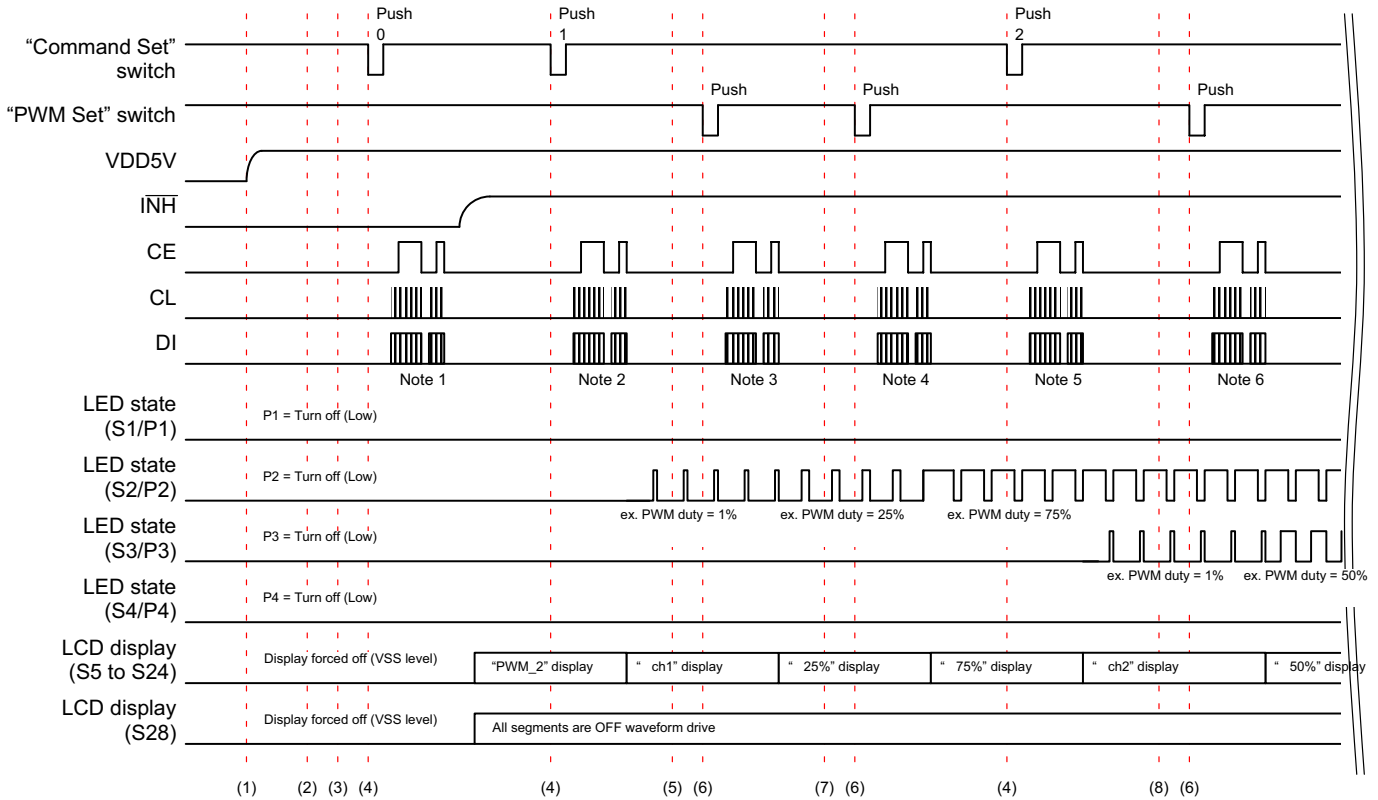

LC75843UGAGEVB

Operation Sequence

1. The power supply of the evaluation board is turned on by moving "POWER" switch to the "ON" position.
2. The evaluation mode is selected by moving "DEMO mode" switch to the "7" position.
3. Set the switches (PF0 to PF3, FC0 to FC3, P1, EXF, OC, SC, BU and W0 to W5) to set control data.

For example, when the PF0 to PF3="L(0), H(1), H(1), L(0)", FC0 to FC3="L(0), H(1), L(0), H(1)", P1="L(0)", EXF="L(0)", OC="L(0)", SC="L(0)", BU="L(0)" and W0 to W5="L(0), L(0), L(0), L(0), L(0), L(0)", are set.

4. The CCB serial data are transferred from a controller circuit to LCD driver IC by pushing the switch of "Command Set".
5. Set the switches of W0 to W5="H(1), H(1), H(1), H(1), L(0), L(0)".
6. The CCB serial data are transferred from a controller circuit to LCD driver IC by pushing the switch of "PWM Set".
7. Set the switches of W0 to W5="H(1), H(1), H(1), H(1), L(0), H(1)".
8. Set the switches of W0 to W5="H(1), H(1), H(1), H(1), L(0), L(0)".
9. Set the switches of W0 to W5="H(1), H(1), H(1), H(1), H(1), H(1)".

Transfer Command Data

Note 1: D1 to D16= all "0" data,
 D17 to D96= "PWM_2" display data,
 D97 to D100= all "0" data, DT0="0", DT1="0",
 DT0="0", DT1="0", PF0 to PF3="0,1,1,0",
 FC0 to FC3="0,1,0,1",
 W10 to W15="0,0,0,0,0,0",
 W20 to W25="0,0,0,0,0,0",
 W30 to W35="0,0,0,0,0,0",
 PS10="0", PS11="0", PS20="0", PS21="0",
 PS30="0", PS31="0", PS40="0", PS41="0",
 P0 to P2="1,0,0",
 DN="1", EXF="0", OC="0", SC="0", BU="0".

"PWM_2" display data is D[96:17] = 0011 0010
 0000 0000 0110 0001 0110 0100 0011 0010
 0100 1100 0000 1000 0010 0110 1000 0110
 0100 0110.

The following figure shows the LCD display contents.

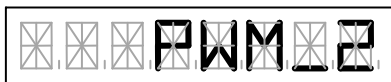

Note 2: D1 to D16= all "0" data, D17 to D96= " ch1"
 display data, W10 to W15="0,0,0,0,0,0",
 W20 to W25="0,0,0,0,0,0",
 W30 to W35="0,0,0,0,0,0",
 PS10="0", PS11="0", PS20="1", PS21="0",
 PS30="0", PS31="0", PS40="0", PS41="0",
 others is set the same.

The following figure shows the LCD display contents.



The PWM channel
 is displayed there.

Note 3: D1 to D16= all "0" data, D17 to D96= " 25%"
 display data, W10 to W15="1,1,1,1,0,0",
 W20 to W25="0,0,0,0,0,0",
 W30 to W35="0,0,0,0,0,0",
 PS10="0", PS11="0", PS20="1", PS21="0",
 PS30="0", PS31="0", PS40="0", PS41="0",
 others is set the same.

The following figure shows the LCD display contents.



The PWM duty is
 displayed there.
 (1 to 100)

Note 4: D1 to D16= all "0" data, D17 to D96= " 75%"
 display data, W10 to W15="1,1,1,1,0,1",
 W20 to W25="0,0,0,0,0,0",
 W30 to W35="0,0,0,0,0,0",
 PS10="0", PS11="0", PS20="1", PS21="0",
 PS30="0", PS31="0", PS40="0", PS41="0",
 others is set the same.

Note 5: D1 to D16= all "0" data, D17 to D96= " ch2"
 display data, W10 to W15="1,1,1,1,0,1",
 W20 to W25="0,0,0,0,0,0",
 W30 to W35="0,0,0,0,0,0",
 PS10="0", PS11="0", PS20="1", PS21="0",
 PS30="0", PS31="1", PS40="0", PS41="0",
 others is set the same.

Note 6: D1 to D16= all "0" data, D17 to D96= " 50%"
 display data, W10 to W15="1,1,1,1,0,1",
 W20 to W25="1,1,1,1,1,0",
 W30 to W35="0,0,0,0,0,0",
 PS10="0", PS11="0", PS20="1", PS21="0",
 PS30="0", PS31="1", PS40="0", PS41="0",
 others is set the same.

LC75843UGAGEVB

Note 7: D1 to D16= all "0" data, D17 to D96= " ch3"
display data, W10 to W15="1,1,1,1,0,1",
W20 to W25="1,1,1,1,1,0",
W30 to W35="0,0,0,0,0,0",
PS10="0", PS11="0", PS20="1", PS21="0",
PS30="0", PS31="1", PS40="1", PS41="1",
others is set the same.

Note 8: D1 to D16= all "0" data, D17 to D96= " 100%"
display data, W10 to W15="1,1,1,1,0,1",
W20 to W25="1,1,1,1,1,0",
W30 to W35="1,1,1,1,1,1",
PS10="0", PS11="0", PS20="1", PS21="0",
PS30="0", PS31="1", PS40="1", PS41="1",
others is set the same.

Note 9: D1 to D16= all "0" data, D17 to D96= " ch1"
display data, W10 to W15="1,1,1,1,0,1",
W20 to W25="1,1,1,1,1,0",
W30 to W35="1,1,1,1,1,1",
PS10="0", PS11="0", PS20="1", PS21="0",
PS30="0", PS31="0", PS40="0", PS41="0",
others is set the same.

Note 10: D1 to D16= all "0" data, D17 to D96= " ch2"
display data, W10 to W15="1,1,1,1,0,1",
W20 to W25="1,1,1,1,1,0",
W30 to W35="1,1,1,1,1,1",
PS10="0", PS11="0", PS20="1", PS21="0",
PS30="0", PS31="1", PS40="0", PS41="0",
others is set the same.

Note 11: D1 to D16= all "0" data, D17 to D96= " ch3"
display data, W10 to W15="1,1,1,1,0,1",
W20 to W25="1,1,1,1,1,0",
W30 to W35="1,1,1,1,1,1",
PS10="0", PS11="0", PS20="1", PS21="0",
PS30="0", PS31="1", PS40="1", PS41="1",
others is set the same.

Note 12: D1 to D16= all "0" data, D17 to D96= " ch1"
display data, W10 to W15="1,1,1,1,0,1",
W20 to W25="1,1,1,1,1,0",
W30 to W35="1,1,1,1,1,1",
PS10="0", PS11="0", PS20="1", PS21="0",
PS30="0", PS31="0", PS40="0", PS41="0",
others is set the same.

Note 13: D1 to D16= all "0" data, D17 to D96= " 100%"
display data, W10 to W15="1,1,1,1,1,1",
W20 to W25="1,1,1,1,1,0",
W30 to W35="1,1,1,1,1,1",
PS10="0", PS11="0", PS20="1", PS21="0",
PS30="0", PS31="0", PS40="0", PS41="0",
others is set the same.

Flowchart

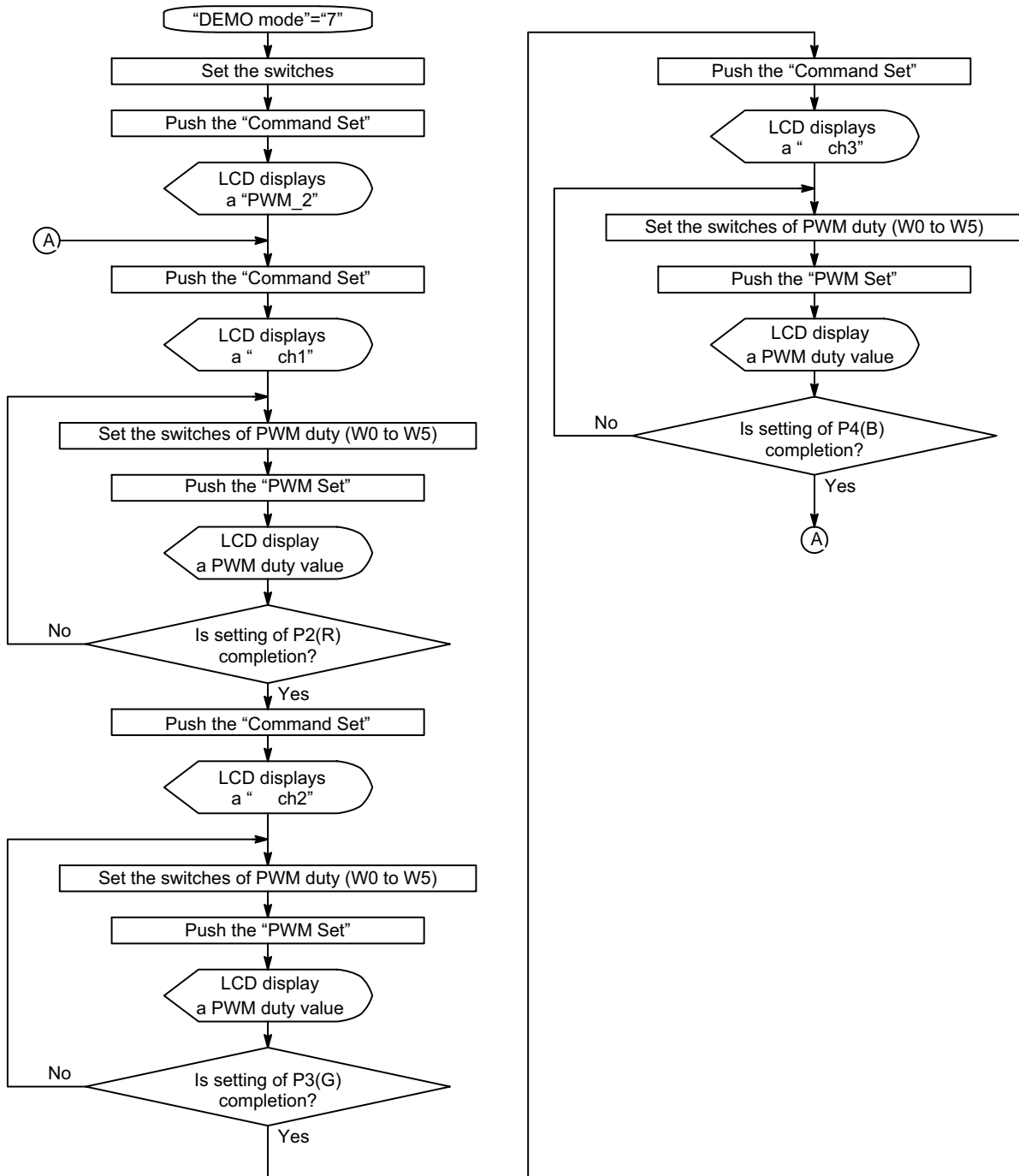

LC75843UGAGEVB

Demonstration (1) Mode Timing (DEMO Mode = "8")

When demonstration mode is "8", LCD number display count ups every second and the LED is eight colors of

lighting. The customer can confirm display of LCD and LED by an automatic demonstration.

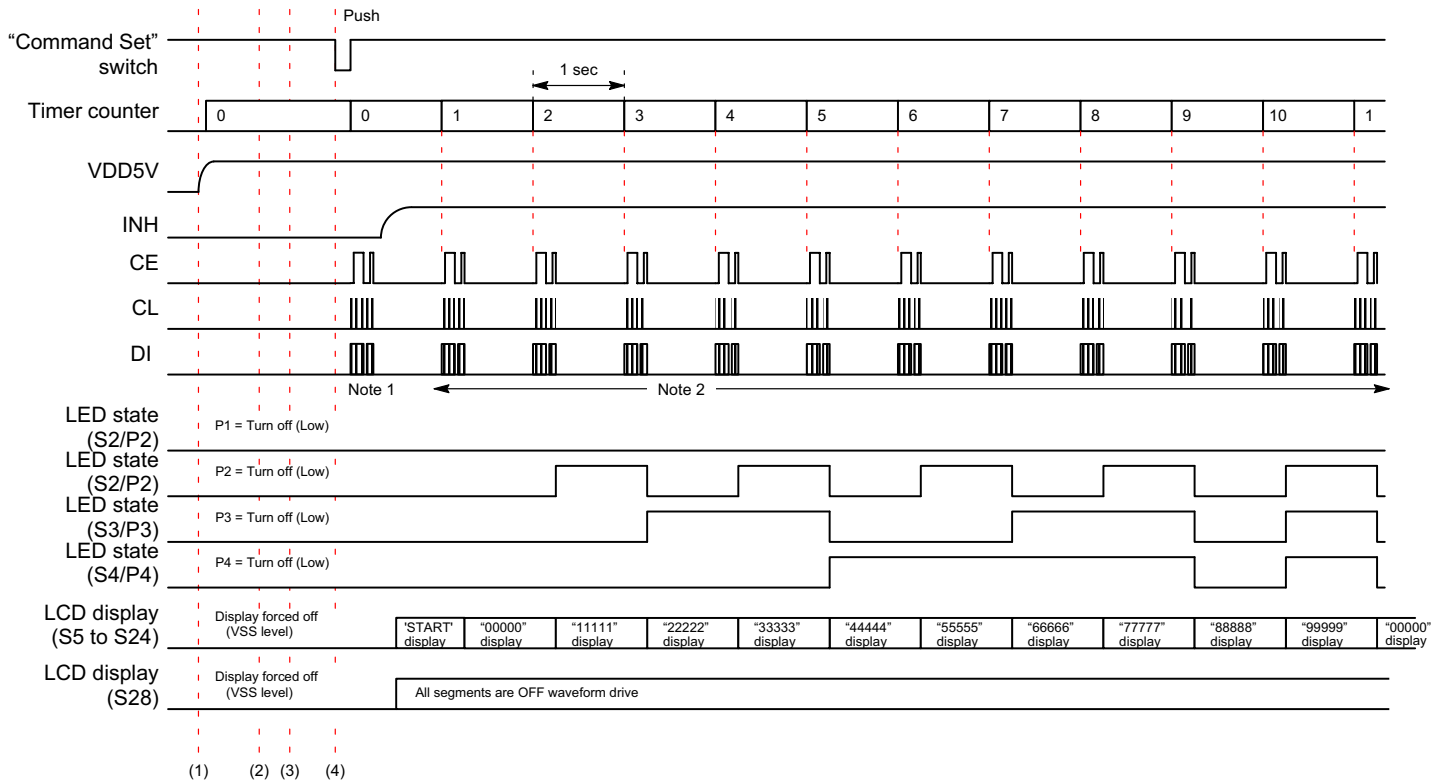

Operation Sequence

1. The power supply of the evaluation board is turned on by moving "POWER" switch to the "ON" position.
2. The automatic demonstration mode is selected by moving "DEMO mode" switch to the "8" position.
3. Set the switches (PF0 to PF3, FC0 to FC3, P1, EXF, OC, SC, BU and W0 to W5) to set control data.
For example, when the PF0 to PF3="L(0), H(1), H(1), L(0)", FC0 to FC3="L(0), H(1), L(0), H(1)", P1="L(0)", EXF="L(0)", OC="L(0)", SC="L(0)", BU="L(0)" and W0 to W5="L(0), L(0), L(0), L(0), L(0), L(0)", are set.
4. The CCB serial data are transferred from a controller circuit to LCD driver IC by pushing the switch of "Command Set".

Transfer Command Data

Note 1: D1 to D16= all "0" data, D17 to D96= "START" display data, D97 to D100= all "0" data, DT0="0", DT1="0", PF0 to PF3="0,1,1,0", FC0 to FC3="0,1,0,1", W10 to W15="0,0,0,0,0,0", W20 to W25="0,0,0,0,0,0", W30 to W35="0,0,0,0,0,0", PS10="0", PS11="0", PS20="0", PS21="0",

PS30="0", PS31="0", PS40="0", PS41="0", P0 to P2="1,0,0", DN="1", EXF="0", OC="0", SC="0", BU="0".

"START" display data is D[96:17] = 0001 1000 0011 0010 0111 0010 0001 1000 0101 0010 0001 0000 1100 0110 0100 0110 0001 0000 0100 1010.

The following figure shows the LCD display contents.

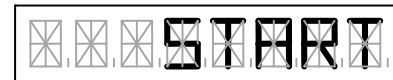

Note 2: The display data by the timer counter value are transferred.

- When "1" : D5,D9,D13="0,0,0", D17 to D96= "00000" display data, Other display data = all "0" data
- When "2" : D5,D9,D13="1,0,0", D17 to D96= "11111" display data, Other display data = all "0" data
- When "3" : D5,D9,D13="0,1,0", D17 to D96= "22222" display data, Other display data = all "0" data
- When "4" : D5,D9,D13="1,1,0", D17 to D96= "33333" display data,

LC75843UGAGEVB

- Other display data = all "0" data
- When "5" : D5,D9,D13="0,0,1", D17 to D96= "44444" display data, Other display data = all "0" data
- When "6" : D5,D9,D13="1,0,1", D17 to D96= "55555" display data, Other display data = all "0" data
- When "7" : D5,D9,D13="0,1,1", D17 to D96= "66666" display data, Other display data = all "0" data
- When "8" : D5,D9,D13="1,1,1", D17 to D96= "77777" display data, Other display data = all "0" data
- When "9" : D5,D9,D13="0,0,0", D17 to D96= "88888" display data,

- Other display data = all "0" data
- When "10" : D5,D9,D13="1,1,1", D17 to D96= "99999" display data, Other display data = all "0" data

"99999" display data is D[96:17] = 0111 0010 0111 0010 0111 0010 0111 0010 0100 1010 0100 1010 0100 1010 0100 1010.

The following figure shows the LCD display contents.

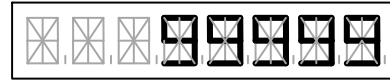

Demonstration (2) Mode Timing (DEMO Mode = "9")

When demonstration mode is "9", PWM duty of the LED drive changes every 100 ms. The customer can confirm

LED brightness adjustment function using PWM duty by an automatic demonstration.

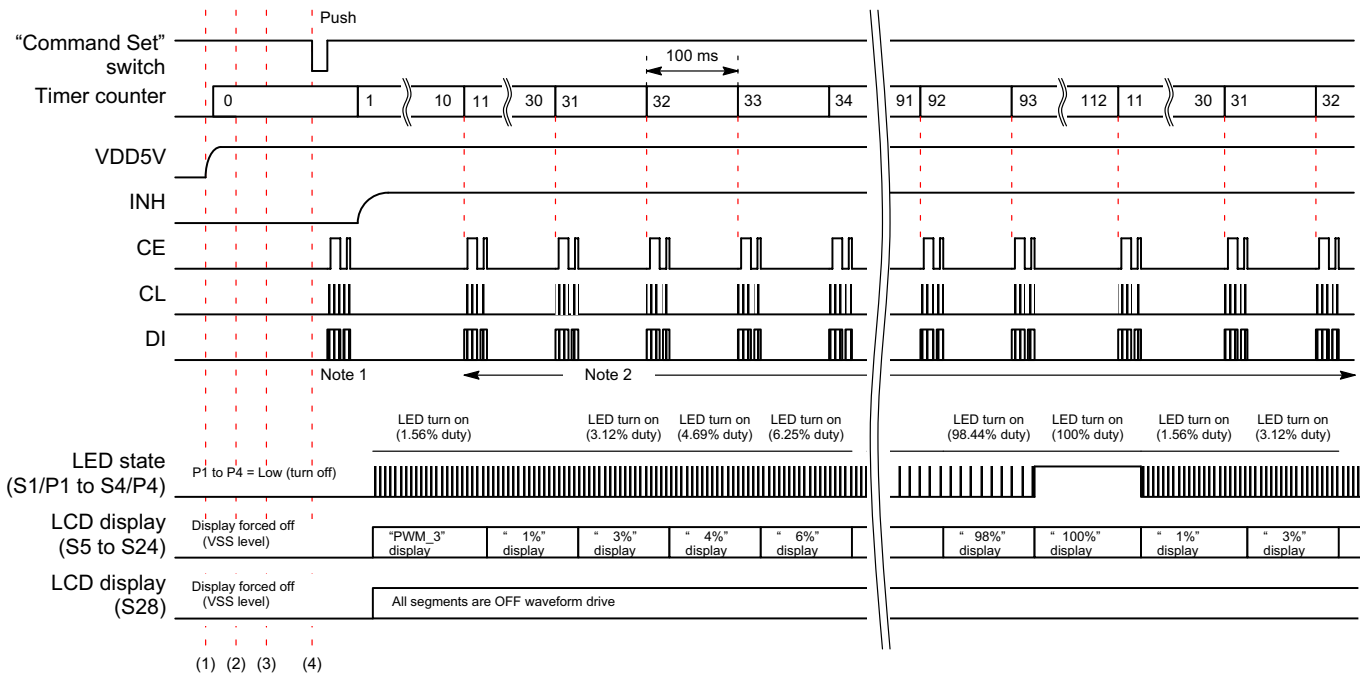

Operation Sequence

1. The power supply of the evaluation board is turned on by moving "POWER" switch to the "ON" position.
2. The automatic demonstration mode is selected by moving "DEMO mode" switch to the "9" position.
3. Set the switches (PF0 to PF3, FC0 to FC3, P1, EXF, OC, SC, BU and W0 to W5) to set control data.
For example, when the PF0 to PF3="L(0), H(1), H(1), L(0)", FC0 to FC3="L(0), H(1), L(0), H(1)", P1="L(0)", EXF="L(0)", OC="L(0)", SC="L(0)", BU="L(0)" and W0 to W5="L(0), L(0), L(0), L(0), L(0), L(0)", are set.

4. The CCB serial data are transferred from a controller circuit to LCD driver IC by pushing the switch of "Command Set".

Transfer Command Data

Note 1: D1 to D16= all "0" data, D17 to D96= "AUTO" display data, D97 to D100= all "0" data, DT0="0", DT1="0", PF0 to PF3="0,1,1,0", FC0 to FC3="0,1,0,1", W10 to W15="0,0,0,0,0,0", W20 to W25="0,0,0,0,0,0", W30 to W35="0,0,0,0,0,0", PS10="1", PS11="1", PS20="1", PS21="0", PS30="0", PS31="1", PS40="1", PS41="1",

LC75843UGAGEVB

P0 to P2="1,0,0",
 DN="1", EXF="0", OC="0", SC="0", BU="0".

"AUTO" display data is D[96:17] = 0111 0010
 0000 0000 0110 0001 0110 0100 0011 0010
 0100 1000 0000 1000 0010 0110 1000 0110
 0100 0110.

The following figure shows the LCD display contents.

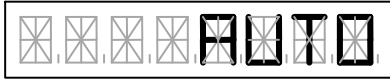

Note 2: D17 to D96= " %" display data,
 W10 to W15, W20 to W25 and W30 to W35 are
 set by the timer counter value. others is set the
 same value.

The following figure shows the LCD display
 contents.



The PWM duty is
 displayed there.
 (1 to 100)

DEMO Mode Change Timing

The following figure shows the timing example when the customer changes the switch of "DEMO mode" successively. The update of the control data and display data in the LCD driver IC does not change only by having changed the switch of "DEMO mode". When the customer

pushed the switch of "Command Set" after having changed the switch of "DEMO mode", command is transferred. The LCD panel display is cleared when the customer pushes the switch of "Command Set" after having set the switch of "DEMO mode" to "0".

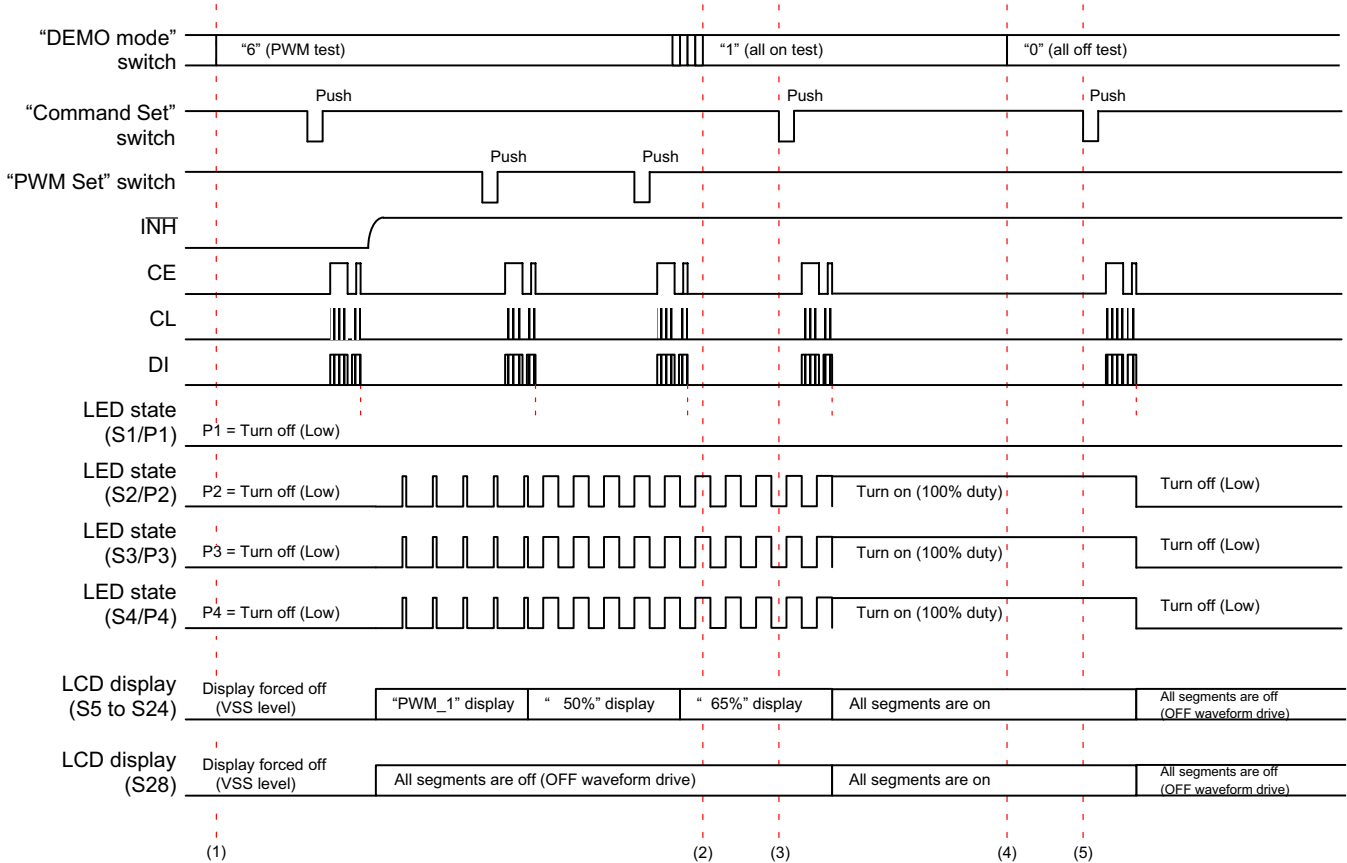

Operation Sequence

1. The evaluation mode can be selected by moving the switch of "DEMO mode".
2. The evaluation mode can be changed by moving the switch of "DEMO mode".
3. The CCB serial data are transferred from a controller circuit to LCD driver IC by pushing the switch of "Command Set".
4. The All OFF test mode is selected by moving "DEMO mode" switch to the "0" position.
5. The CCB serial data are transferred from a controller circuit to LCD driver IC by pushing the switch of "Command Set". Thereby, the LCD panel display is cleared.

LC75843UGAGEVB

OSCILLOSCOPE OBSERVATION WAVEFORM

Waveform of All OFF Test Mode (DEMO Mode = "0")

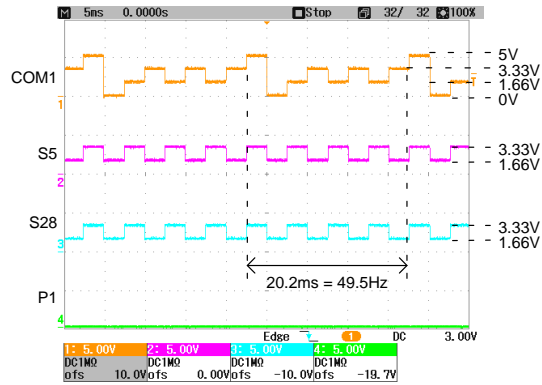

Figure 22. LCD Drive Waveform (SC = 0, BU = 0)

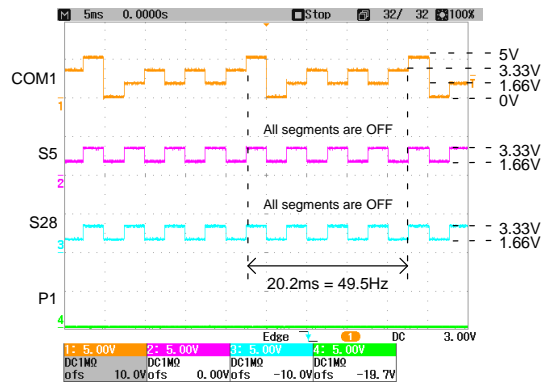

Figure 23. LCD Drive Waveform (SC = 1, BU = 0)

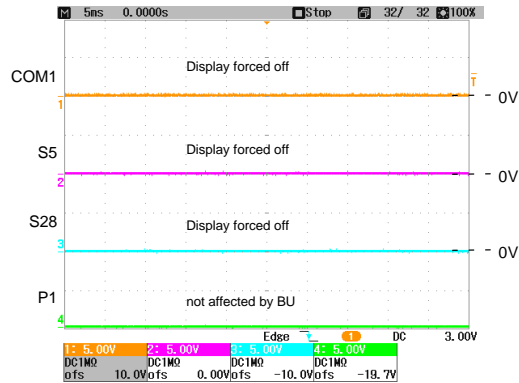

Figure 24. LCD Drive Waveform (SC = 0, BU = 1)

LC75843UGAGEVB

Waveform of All ON Test Mode (DEMO Mode = "1")

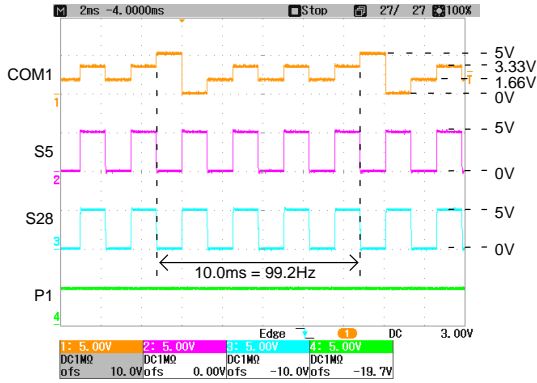

Figure 25. LCD Drive Waveform (SC = 0, BU = 0)

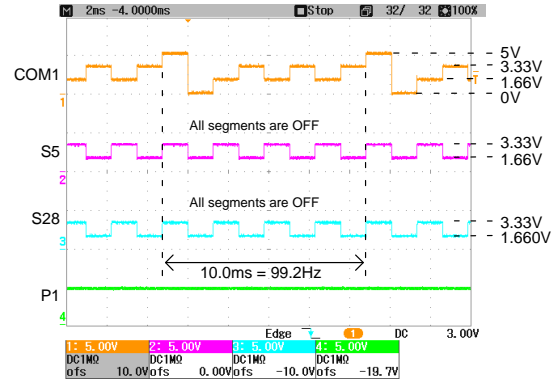

Figure 26. LCD Drive Waveform (SC = 1, BU = 0)

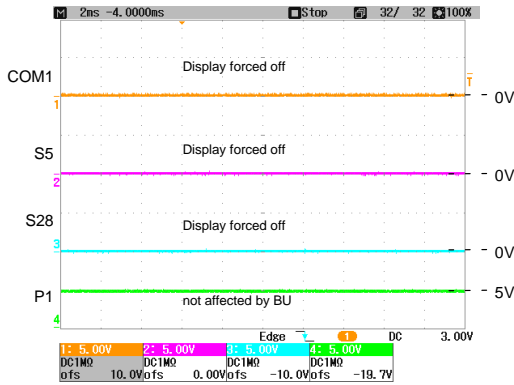

Figure 27. LCD Drive Waveform (SC = 0, BU = 1)

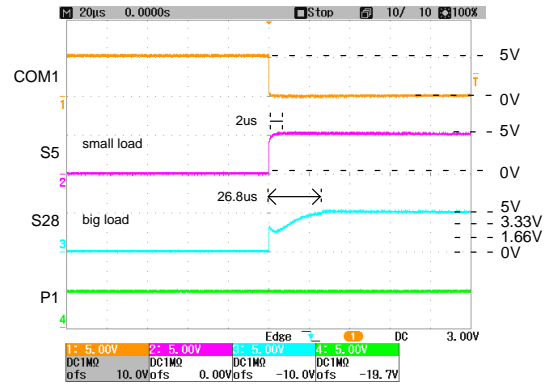

Figure 28. LCD Drive Rising Waveform of Big Load (SC = 0, BU = 0, P1 = 1)

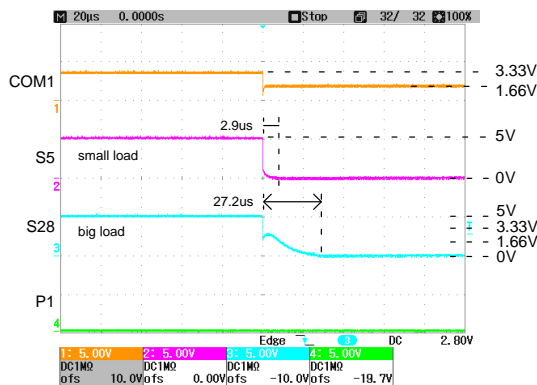

Figure 29. LCD Drive Falling Waveform of Big Load (SC = 0, BU = 0, P1 = 0)

LC75843UGAGEVB

Waveform of LCD Display Test (1) Mode (DEMO Mode = "2")

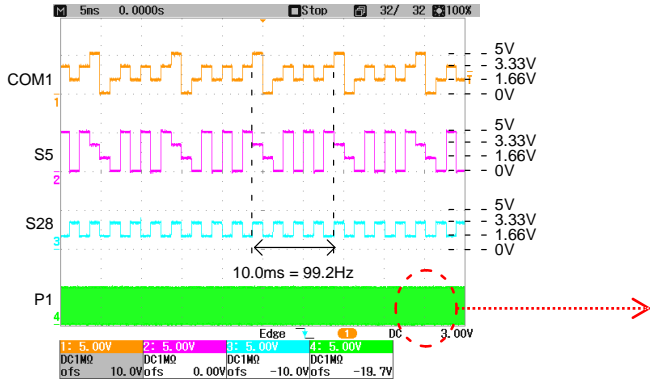

Figure 30. Monitor Clock Output from a General-Purpose Port

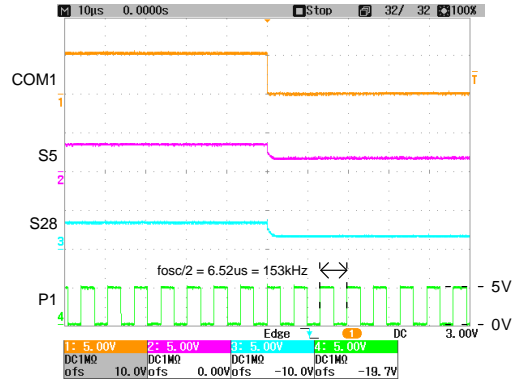

Figure 31. Monitor Clock Output from a General-Purpose Port (Zoom In)

Waveform of LCD Display Test (2) Mode (DEMO Mode = "3")

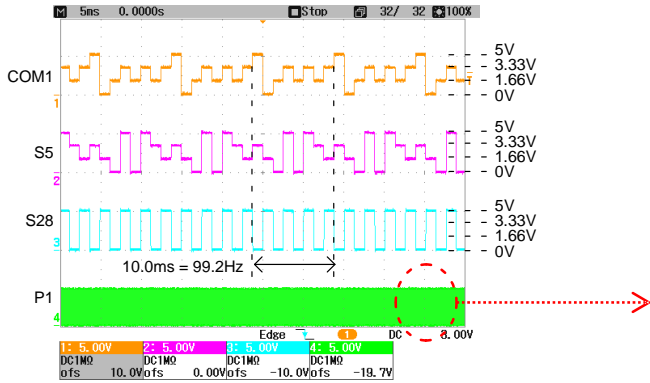

Figure 32. Monitor Clock Output from a General-Purpose Port

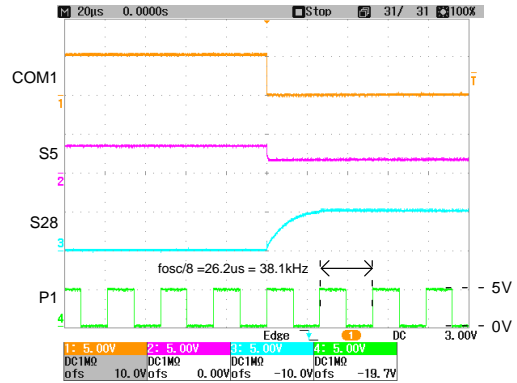

Figure 33. Monitor Clock Output from a General-Purpose Port (Zoom In)

LC75843UGAGEVB

Waveform of LED (PWM) Test (1) Mode (DEMO Mode = "6")

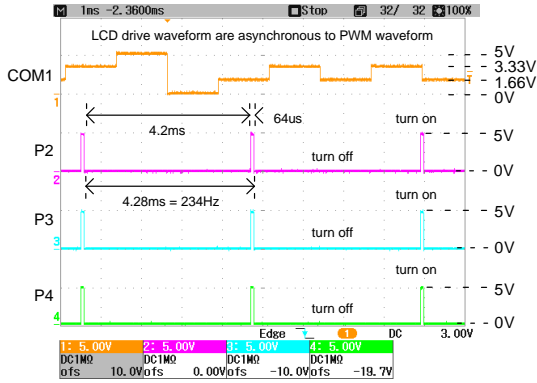

Figure 34. 1%-duty PWM Drive Waveform (PF0 to PF3 = 0100, W0 to W5 = 000000)

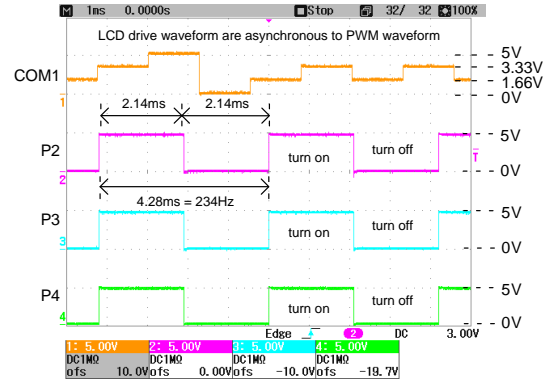

Figure 35. 50%-duty PWM Drive Waveform (PF0 to PF3 = 0100, W0 to W5 = 111110)

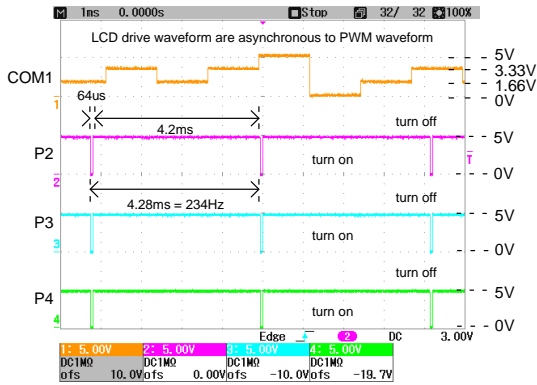

Figure 36. 98%-duty PWM Drive Waveform (PF0 to PF3 = 0100, W0 to W5 = 011111)

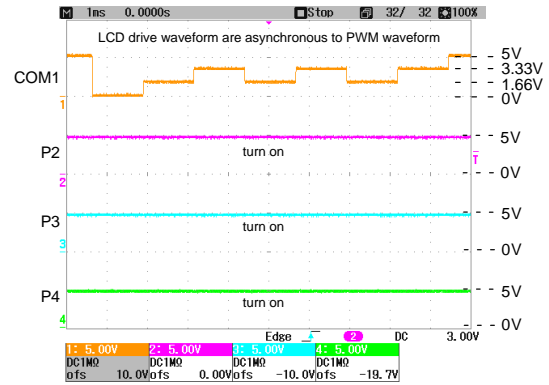

Figure 37. 100%-duty PWM Drive Waveform (PF0 to PF3 = 0100, W0 to W5 = 111111)

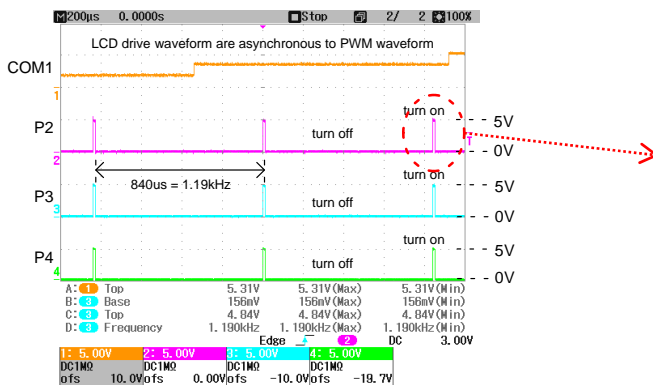

Figure 38. 1%-duty PWM Drive Waveform (PF0 to PF3 = 0101, W0 to W5 = 000000)

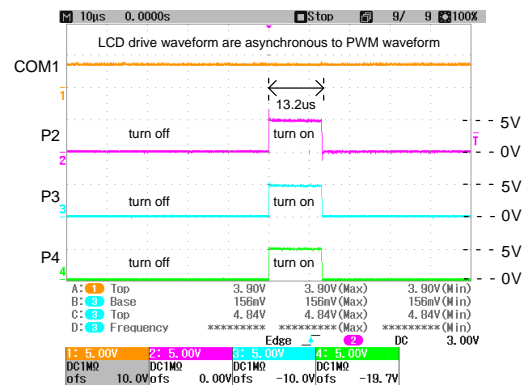

Figure 39. 1%-duty PWM Drive Waveform (Zoom In)

LC75843UGAGEVB

Waveform of LCD Drive Output

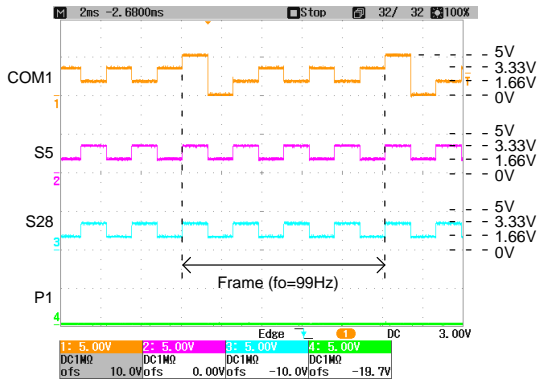

Figure 40. 1/4 Duty LCD Drive Scheme
(JPDT0 = Remove, JPDT1 = Remove)

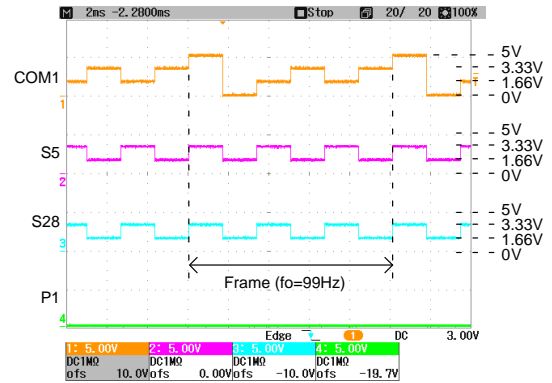

Figure 41. 1/3 Duty LCD Drive Scheme
(JPDT0 = Insert, JPDT1 = Remove)

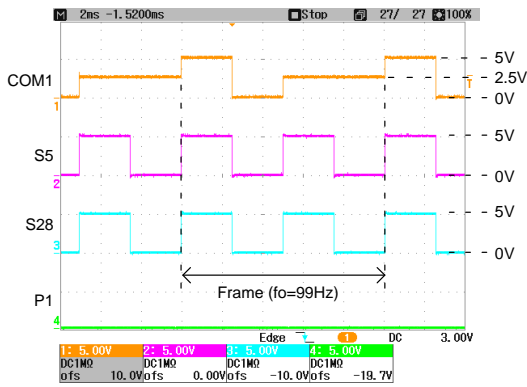

Figure 42. 1/2 Duty LCD Drive Scheme
(JPDT0 = Remove, JPDT1 = Insert)

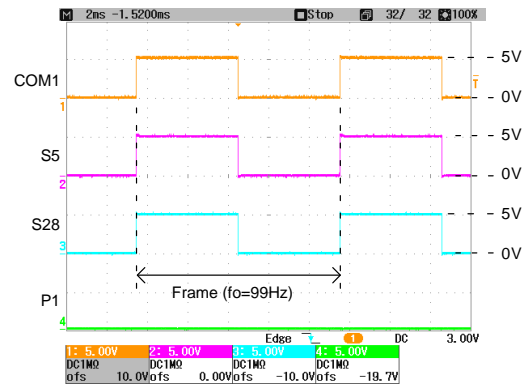

Figure 43. 1/1 Duty LCD Drive Scheme
(JPDT0 = Insert, JPDT1 = Insert)

LC75843UGAGEVB

PRINTED CIRCUIT BOARD LAYOUT

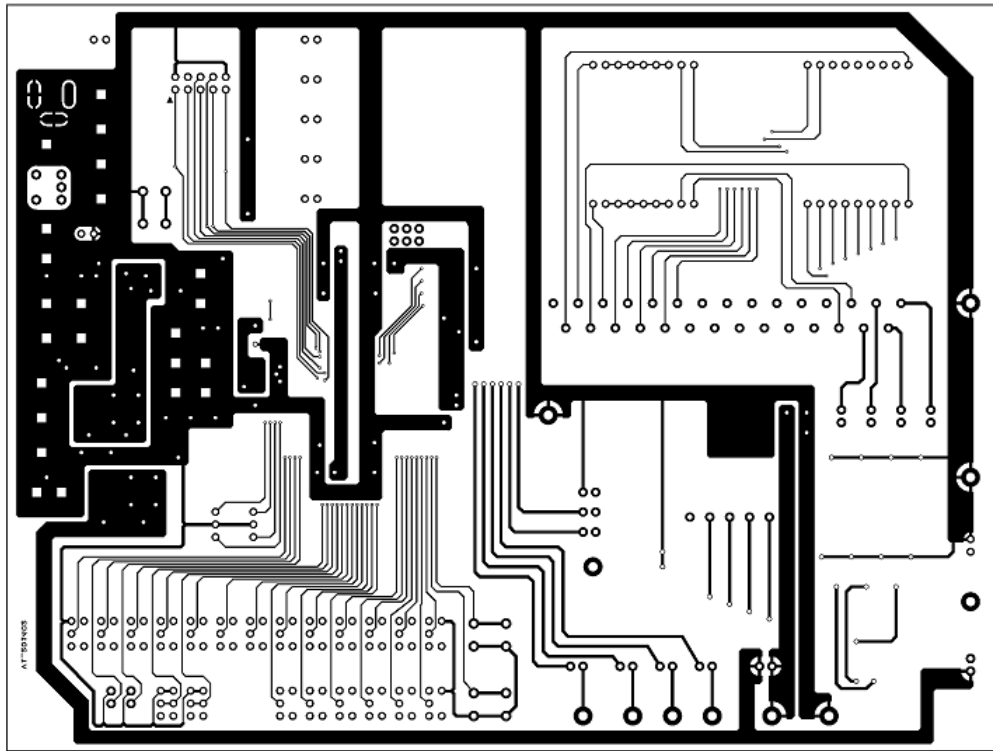

Figure 44. Pattern1 Layer of LC75843UGAGEVB Reference Design

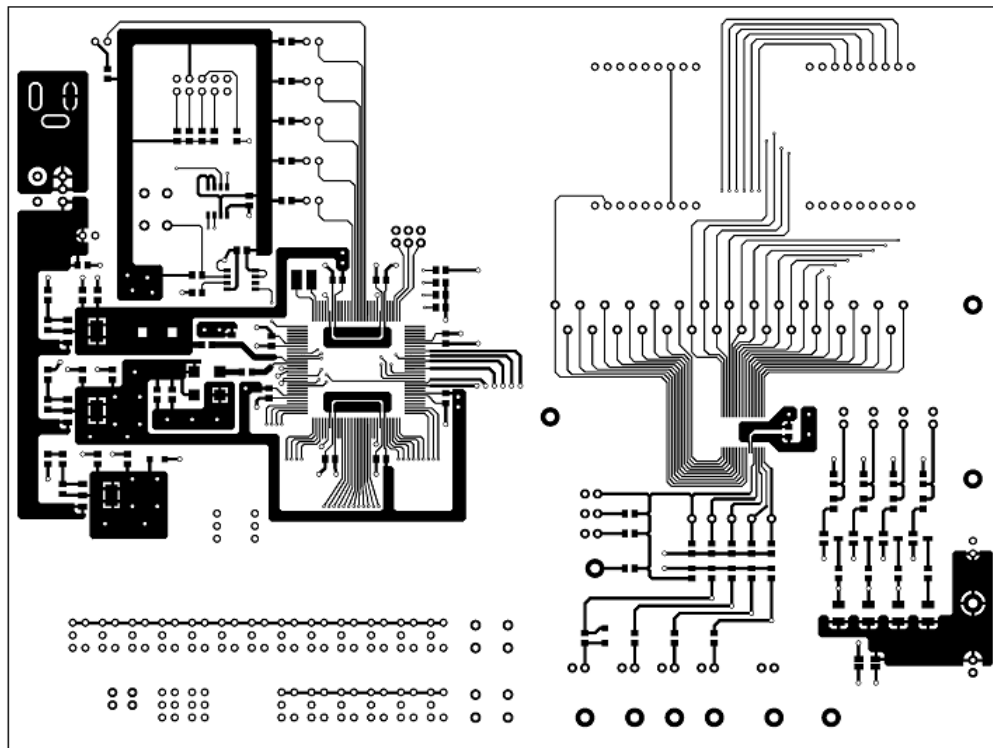

Figure 45. Pattern2 Layer of LC75843UGAGEVB Reference Design

LC75843UGAGEVB

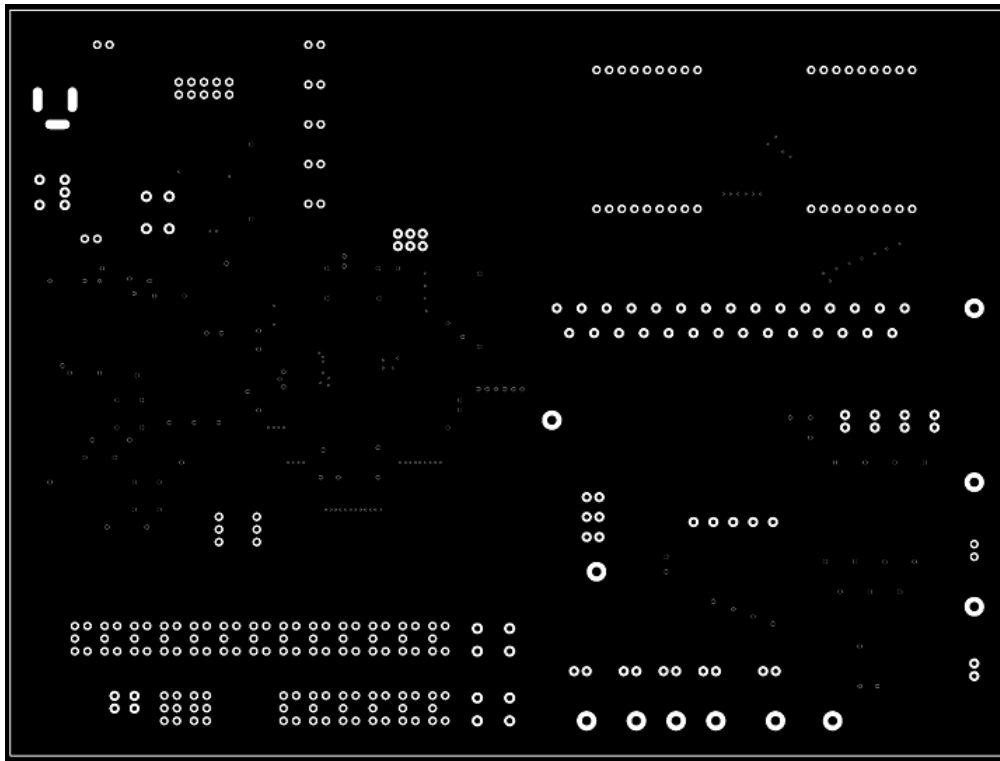

Figure 46. Regist1 Layer of LC75843UGAGEVB Reference Design

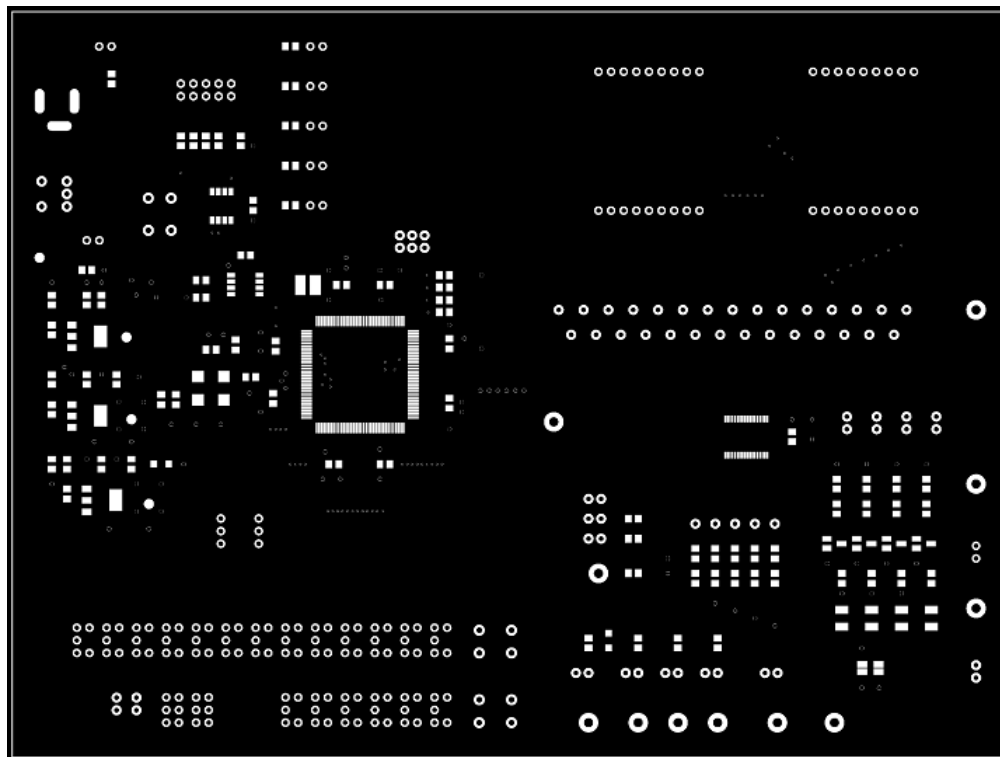

Figure 47. Regist2 Layer of LC75843UGAGEVB Reference Design

LC75843UGAGEVB

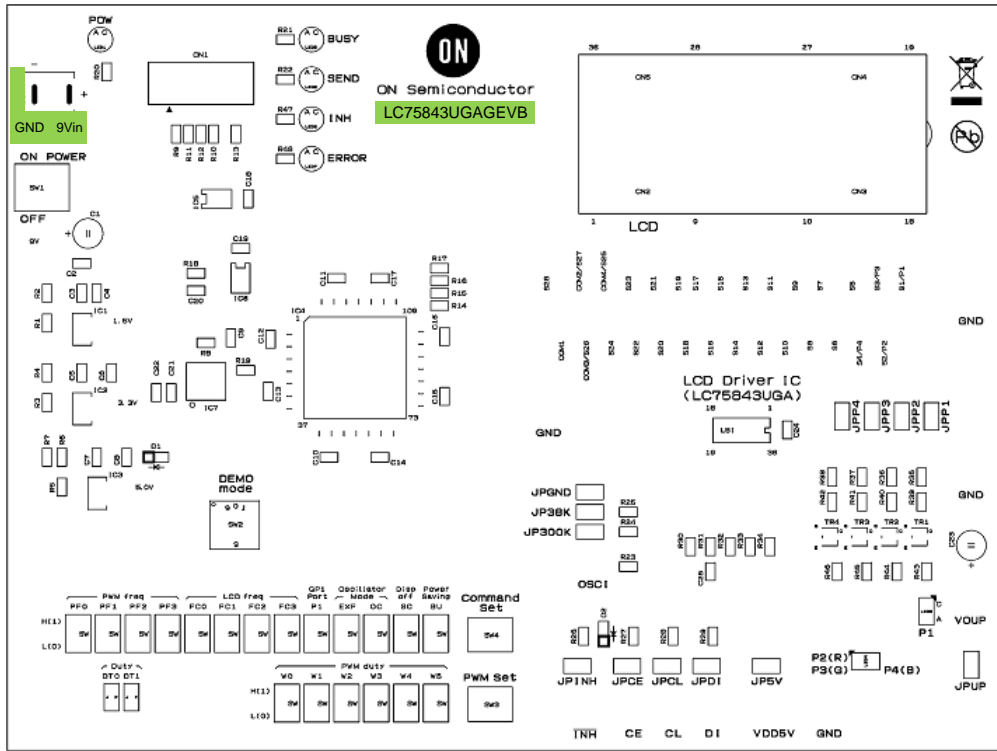

Figure 48. Silk2 Layer of LC75843UGAGEVB Reference Design

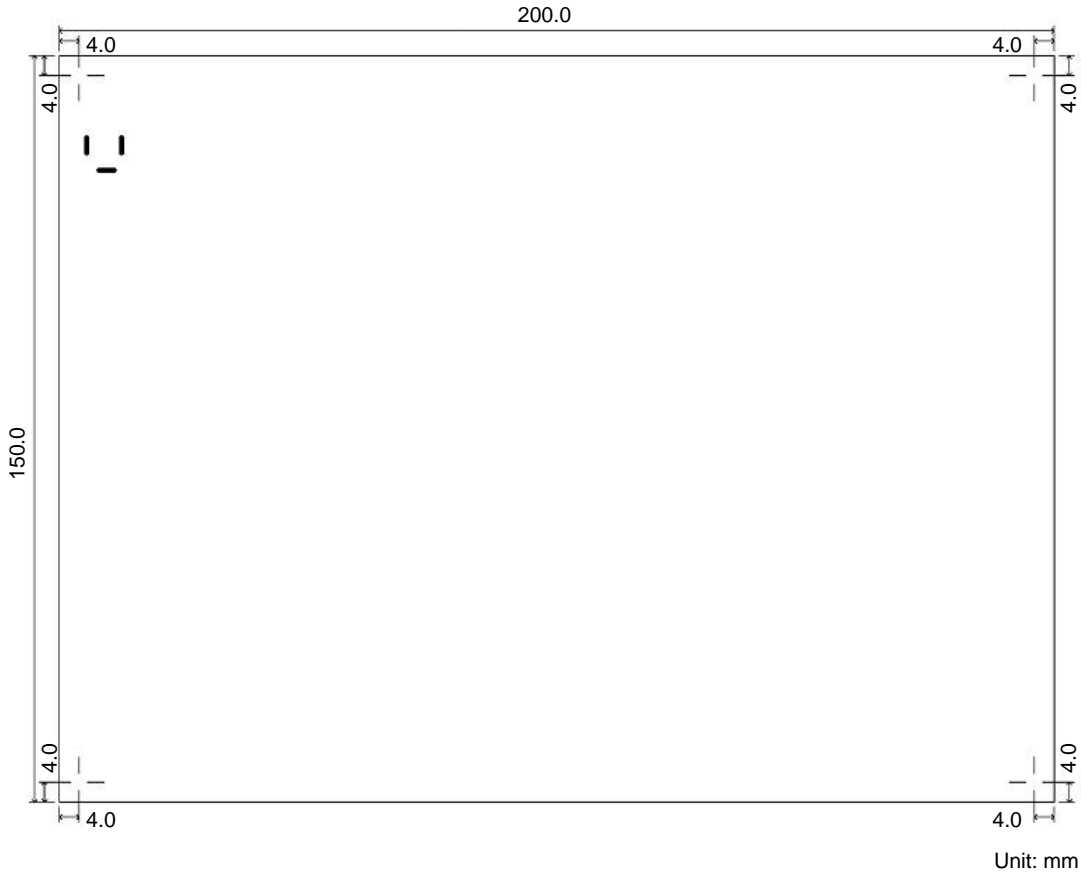

Figure 49. Outside Dimension of LC75843UGAGEVB Reference Design

LC75843UGAGEVB

ABOUT THE USE OF THE AC ADAPTER

If the customer prepares parts and remodels it by soldering, the customer can change a main power supply into an evaluation board supplied from an AC adapter. In this

case, please be careful about polarity enough. When the AC adapter of the wrong polarity was used, the evaluation board may be damaged.

Table 15. RECOMMENDATION PARTS

Description	Manufacturer	Manufacturer Part Number	Explanation	Lead Free
DC power jack	Marushin Electric Mfg	MJ-179PH	Mate Plug 2.1 mm	Yes
AC adapter	Go Forward Enterprise	GF12-US0913	DC9V, Center Plus	Yes

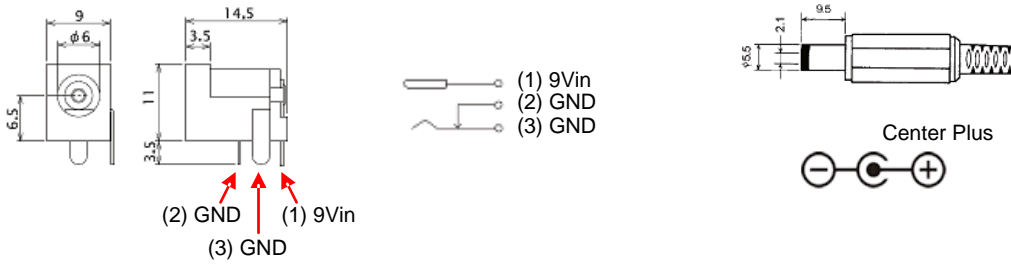

Contents of Alteration Work

- (1) Remove the Socket Pins (“9Vin”, “GND”).
- (2) Take Off a Label.
- (3) Soldering the DC Power Jack.

(1) Remove the Socket Pins



(2) Take Off a Label



(3) Soldering the DC Power Jack



LC75843UGAGEVB

BILL OF MATERIALS

Table 16. BILL OF MATERIALS OF LC75843UGA EVALUATION BOARD (LC75843UGAGEVB)

Designator	Qty.	Description	Part Number	Value	Manufacturer
IC1-IC3	3	Linear Regulator (LDO)	LM317EMP	1.2 V to 37 V, 1 Amax	National Semiconductors
IC4	1	FPGA (Cyclone)	EP1C3T144C8N	TQFP144	ALTERA
IC5	1	Configuration ROM (EEPROM)	EPCS1SI8N	1 Mbit	ALTERA
IC6	1	Power Supply Voltage Supervisors	TLC7733ID	VTH = 2.93 V	TI
IC7	1	Crystal Oscillator	KC7050B50.0000C31B00	50.0000 MHz	KYOCERA
LSI	1	LCD Driver IC	LC75843UGA	1/1 to 1/4 Duty, 100 Segments(max)	ON Semiconductor
LCD	1	LCD Panel	VIM-828-DP5.7-6-HV-RH-W	14SEGx8DIGIT, 1/4 Duty	Varitronix
TR1-TR4	4	NPN Transistor	2SC2712-GR(F)	VCEO = 50 V, Ic = 150 mA	Toshiba
D1, D2	2	Diode	MMSD4148T	VR = 100 V, IF = 0.2 A	ON Semiconductor
LED1, LED7	1	LED	L-934ID	Red, D = 3 mm	Kingbright
LED2, LED3, LED6	3	LED	L-934SGD	Green, D = 3 mm	Kingbright
LED4	1	LED	LATBT66B	RGB-color, Anode Common	Siemens AG (OSRAM)
LED5	1	LED	MSML-A101-S00J1	Orange	Avago TECHNOLOGIES
R8	1	Resistor	MCR10EZPF10R0	10 Ω ±1%, 1/8 W	ROHM
R2	1	Resistor	MCR10EZPF51R0	51 Ω ±1%, 1/8 W	ROHM
R46	1	Resistor	MCR10EZPF82R0	82 Ω ±1%, 1/8 W	ROHM
R45	1	Resistor	MCR10EZPF91R0	91 Ω ±1%, 1/8 W	ROHM
R19	1	Resistor	MCR10EZPF1000	100 Ω ±1%, 1/8 W	ROHM
R43, R44	2	Resistor	MCR10EZPF2000	200 Ω ±1%, 1/8 W	ROHM
R1, R3	2	Resistor	MCR10EZPF2400	240 Ω ±1%, 1/8 W	ROHM
R5	1	Resistor	MCR10EZPF3300	330 Ω ±1%, 1/8 W	ROHM
R6	1	Resistor	MCR10EZPF3600	360 Ω ±1%, 1/8 W	ROHM
R4, R23-R25, R27-R29	7	Resistor	MCR10EZPF3900	390 Ω ±1%, 1/8 W	ROHM
R7	1	Resistor	MCR10EZPF6200	620 Ω ±1%, 1/8 W	ROHM
R9, R10, R20-R22, R39-R42, R47, R48	11	Resistor	MCR10EZPF1001	1 kΩ ±1%, 1/8 W	ROHM
R11-R18	8	Resistor	MCR10EZPF1002	10 kΩ ±1%, 1/8 W	ROHM
R26	1	Resistor	MCR10EZPF3002	30 kΩ ±1%, 1/8 W	ROHM
R30-R38	9	Resistor	MCR10EZPF1003	100 kΩ ±1%, 1/8 W	ROHM
C21	1	Multilayer Ceramic Capacitor	C2012JB2E102K	1000 pF ±10%, 250 V	TDK
C2, C3, C5, C7, C9-C19, C22, C24	17	Multilayer Ceramic Capacitor	GRM21BB11H104KA01L	0.1 μF ±10%, 50 V	Murata
C4, C6, C8, C20, C25	5	Multilayer Ceramic Capacitor	GRM21BB31A106KE18L	10 μF ±10%, 10 V	Murata
C1, C23	2	Aluminum Electrolytic Capacitor	25PK100MEFC5X11	100 μF ±20%, 25 V	Rubycon
SW1	1	Toggle Switch	A-12AH	ON-ON, Right Angle, 0.4 VA MAX 28 V	NIKKAI
SW5-SW23	19	Toggle Switch	G-12AP	ON-ON, Straight, 0.4 VA MAX 28 V	NIKKAI
SW3, SW4	2	Push Button Switch	B3F-1002	H = 5 mm, 150 g	OMRON
SW2	1	Rotary Code Switch	ERD210RSZ	Shift Type, 0 to 9, BCD, Real Code	Excel Cell Electronic
CN1	1	Connector	HIF3FC-10PA-2.54DSA(71)	10pin, Straight, Polarity Slot 1	HIROSE
CN2-CN5	4	Socket Terminal	FHU-1x42SG	9pin	Useconn Electronics

LC75843UGAGEVB

Table 16. BILL OF MATERIALS OF LC75843UGA EVALUATION BOARD (LC75843UGAGEVB) (continued)

Designator	Qty.	Description	Part Number	Value	Manufacturer
VDD5V, VOUP, GND1–GND4, OSCI, INH, CE, CL, DI	11	Check Terminal	WT-2-1	D = 3 mm, H = 10 mm	MAC8
S1–S24, S28	25	Check Terminal	LC-2-G-White	White	MAC8
COM1–COM4	4	Check Terminal	LC-2-G-Skyblue	Skyblue	MAC8
JPDT0, JPDT1, JP5V, JP300K, JP38K, JPGND, JPINH, JPCE, JPCL, JPDI, JPUP, JPP1–JPP4, 9Vin, GND	17	Socket Pin	W81102T3825RC	2pin	RS Components
SP5V, SPUP	2	Jump Socket	MJ254-6RD	Red	Useconn Electronics
SPOSCI	1	Jump Socket	MJ254-6BU	Blue	Useconn Electronics
SPINH, SPCE, SPCL, SPDI	4	Jump Socket	MJ254-6WH	White	Useconn Electronics
SPP1–SPP4	4	Jump Socket	MJ254-6GN	Green	Useconn Electronics
	1	Printed Board	LC75843UGAGEVBPCB	200 × 150 mm, t = 1.6 mm, 2-levels, FR-4	ON Semiconductor
	4	Screw		M3	
	4	Nut		M3	
	4	Natural Rubber Foot	BU-692-A	Black, M15 × 7.5 mm	SATO PARTS

CCB is a registered trademark of Semiconductor Components Industries, LLC.

ON Semiconductor and  are registered trademarks of Semiconductor Components Industries, LLC (SCILLC). SCILLC owns the rights to a number of patents, trademarks, copyrights, trade secrets, and other intellectual property. A listing of SCILLC's product/patent coverage may be accessed at www.onsemi.com/site/pdf/Patent-Marking.pdf. SCILLC reserves the right to make changes without further notice to any products herein. SCILLC makes no warranty, representation or guarantee regarding the suitability of its products for any particular purpose, nor does SCILLC assume any liability arising out of the application or use of any product or circuit, and specifically disclaims any and all liability, including without limitation special, consequential or incidental damages. "Typical" parameters which may be provided in SCILLC data sheets and/or specifications can and do vary in different applications and actual performance may vary over time. All operating parameters, including "Typicals" must be validated for each customer application by customer's technical experts. SCILLC does not convey any license under its patent rights nor the rights of others. SCILLC products are not designed, intended, or authorized for use as components in systems intended for surgical implant into the body, or other applications intended to support or sustain life, or for any other application in which the failure of the SCILLC product could create a situation where personal injury or death may occur. Should Buyer purchase or use SCILLC products for any such unintended or unauthorized application, Buyer shall indemnify and hold SCILLC and its officers, employees, subsidiaries, affiliates, and distributors harmless against all claims, costs, damages, and expenses, and reasonable attorney fees arising out of, directly or indirectly, any claim of personal injury or death associated with such unintended or unauthorized use, even if such claim alleges that SCILLC was negligent regarding the design or manufacture of the part. SCILLC is an Equal Opportunity/Affirmative Action Employer. This literature is subject to all applicable copyright laws and is not for resale in any manner.

PUBLICATION ORDERING INFORMATION

LITERATURE FULFILLMENT:

Literature Distribution Center for ON Semiconductor
P.O. Box 5163, Denver, Colorado 80217 USA
Phone: 303-675-2175 or 800-344-3860 Toll Free USA/Canada
Fax: 303-675-2176 or 800-344-3867 Toll Free USA/Canada
Email: orderlit@onsemi.com

N. American Technical Support: 800-282-9855 Toll Free
USA/Canada
Europe, Middle East and Africa Technical Support:
Phone: 421 33 790 2910
Japan Customer Focus Center
Phone: 81-3-5817-1050

ON Semiconductor Website: www.onsemi.com
Order Literature: <http://www.onsemi.com/orderlit>
For additional information, please contact your local Sales Representative



Компания «ЭлектроПласт» предлагает заключение долгосрочных отношений при поставках импортных электронных компонентов на взаимовыгодных условиях!

Наши преимущества:

- Оперативные поставки широкого спектра электронных компонентов отечественного и импортного производства напрямую от производителей и с крупнейших мировых складов;
- Поставка более 17-ти миллионов наименований электронных компонентов;
- Поставка сложных, дефицитных, либо снятых с производства позиций;
- Оперативные сроки поставки под заказ (от 5 рабочих дней);
- Экспресс доставка в любую точку России;
- Техническая поддержка проекта, помощь в подборе аналогов, поставка прототипов;
- Система менеджмента качества сертифицирована по Международному стандарту ISO 9001;
- Лицензия ФСБ на осуществление работ с использованием сведений, составляющих государственную тайну;
- Поставка специализированных компонентов (Xilinx, Altera, Analog Devices, Intersil, Interpoint, Microsemi, Aeroflex, Peregrine, Syfer, Eurofarad, Texas Instrument, Miteq, Cobham, E2V, MA-COM, Hittite, Mini-Circuits, General Dynamics и др.);

Помимо этого, одним из направлений компании «ЭлектроПласт» является направление «Источники питания». Мы предлагаем Вам помощь Конструкторского отдела:

- Подбор оптимального решения, техническое обоснование при выборе компонента;
- Подбор аналогов;
- Консультации по применению компонента;
- Поставка образцов и прототипов;
- Техническая поддержка проекта;
- Защита от снятия компонента с производства.



Как с нами связаться

Телефон: 8 (812) 309 58 32 (многоканальный)

Факс: 8 (812) 320-02-42

Электронная почта: org@eplast1.ru

Адрес: 198099, г. Санкт-Петербург, ул. Калинина, дом 2, корпус 4, литера А.