

### General Description

The RFFM4227 is a low noise amplifier (LNA) designed for Wi-Fi 802.11b/g/n systems. The integrated input and output 50Ω match minimizes layout area in the customer's application, reduces the bill of materials and manufacturability cost. Performance is focused on a balance of low noise and gain that increases the receive sensitivity.

The RFFM4227 integrates a bypass path that enables a defined gain step. The device is provided in a 1.6mm x 1.6mm x 0.5mm, 6-pin DFN package.



6 Pad 1.6 x 1.6 mm DFN Package

### Product Features

- 2400 – 2500 MHz
- 15 dB LNA Gain
- 1.3 dB Noise Figure
- 6 dB Bypass Loss
- Input and Output Matched to 50 Ω
- Integrated 5 GHz Rejection Filter
- 1.6 x 1.6 mm DFN Package

### Functional Block Diagram

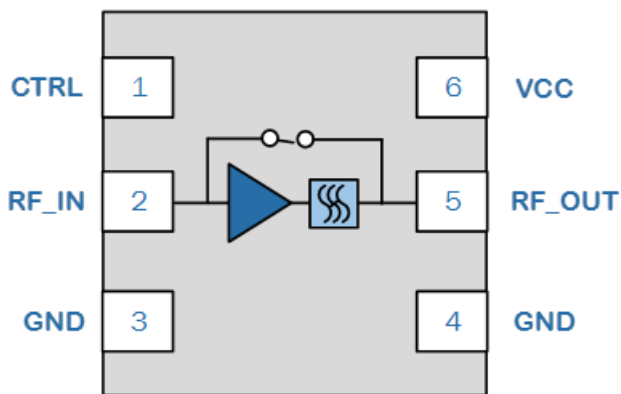

Top View

### Applications

- Wireless Routers
- Access Points
- Residential Gateways
- Customer Premise Equipment
- Internet of Things

### Ordering Information

Part No.	Description
RFFM4227SB	Sample Bag with 5 pcs
RFFM4227SQ	Sample Bag with 25 pcs
RFFM4227SR	7" Reel with 100 pcs
RFFM4227TR7	7" Reel with 2,500 pcs
RFFM4227TR13-10k	13" Reel with 10,000 pcs
RFFM4227PCK-410	Assembled Evaluation Board + 5 pcs

### Absolute Maximum Ratings

Parameter	Rating
DC Supply Voltage (No RF Applied)	-0.3 to +5.5 V <sub>DC</sub>
Control Voltage	-0.5 to +4 V <sub>DC</sub>
Storage Temperature	-40 to +150 °C
RF Input Power into 50 Ω Load for 802.11b/g/ in LNA On Mode (No Damage)	+20 dBm
RF Input Power into 50 Ω Load for 802.11b/g/ in <u>Bypass</u> Mode (No Damage)	+30 dBm

Exceeding any one or a combination of the Absolute Maximum Rating conditions may cause permanent damage to the device. Extended application of Absolute Maximum Rating conditions to the device may reduce device reliability.

### Recommended Operating Conditions

Parameter	Min	Typ	Max	Units
Operating Frequency	2400		2500	MHz
Operating Temperature	-40		+85	°C
Power Supply Voltage V <sub>CC</sub>	3	5	6	V
Control Voltage - High	2.8	3.1	3.3	V
Control Voltage - Low	0		0.2	V

Electrical specifications are measured at specified test conditions. Specifications are not guaranteed over all recommended operating conditions.

### Electrical Specifications

Parameter	Conditions	Min	Typ	Max	Units
<b>LNA MODE</b>					
Unless otherwise noted: V <sub>CC</sub> = 3.3V, T = +25 °C, CTRL = High					
Noise Figure			1.3	1.6	dB
Small Signal Gain		14	15		dB
Gain Flatness Across any 40 MHz Channel		-0.2		0.2	dB
RF_IN Port Return Loss			8	6	dB
RF_OUT Port Return Loss			15	10	dB
Input P <sup>1dB</sup>		-7	-5		dBm
Input IP3	P <sub>IN</sub> = -20 dBm		+3		dBm
RX Operating Current			9	20	mA
I <sub>CTRL</sub> Current			500		μA
<b>BYPASS MODE</b>					
Unless otherwise noted: V <sub>CC</sub> = 3.3V, T = +25 °C, CTRL = High					
Bypass Loss			6		dB
Loss Flatness Across any 40 MHz Channel		-0.2		0.2	dB
RF_IN Port Return Loss			8	7	dB
RF_OUT Port Return Loss			8	7	dB
Input P <sup>1dB</sup>		+18	+20		dBm
Input IP3	P <sub>IN</sub> = -5 dBm		+29		dBm
RX Operating Current			20	50	μA
<b>GENERAL SPECIFICATIONS</b>					
Gain Switch Time – 50 to 90% RF Output	Switching from Bypass to LNA Mode		325		nS
Gain Switch Time – 50 to 10% RF Output	Switching from LNA to Bypass Mode		100		nS

### Control Logic Truth Table

OPERATING MODE	CTRL
LNA Mode	High
Bypass Mode	Low

### Evaluation Board Schematic

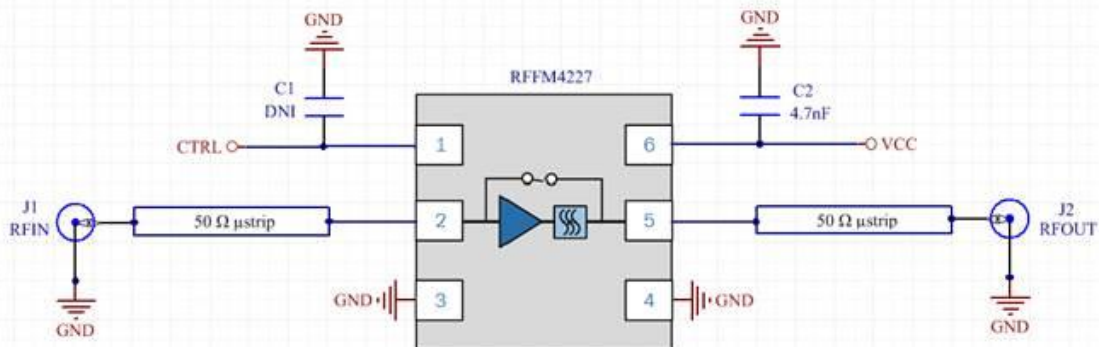

### Pin Configuration and Description

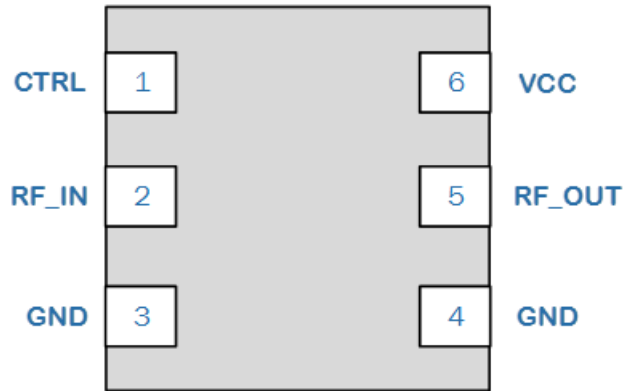

Top View

Pad No.	Label	Description
1	CTRL	Control voltage
2	RF_IN	RF input. This port is matched to 50 $\Omega$ and DC blocked
3	GND	Ground connection
4	GND	Ground connection
5	RF_OUT	RF output. This port is matched to 50 $\Omega$ and DC blocked .
6	VCC	Supply voltage
Package Base	GND	RF/DC ground. Use recommended via pattern to minimize inductance and thermal resistance. See PCB Mounting Pattern for suggested footprint.

### Package Dimensions

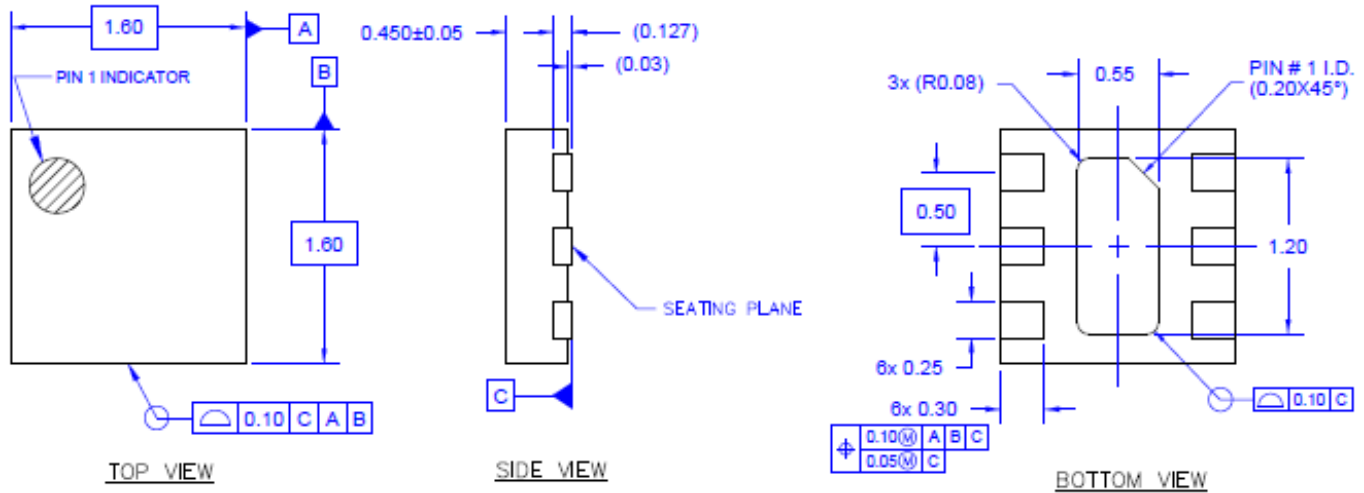

- Notes:
1. All dimensions are in millimeters. Angles are in degrees.
  2. The terminal #1 identifier and terminal numbering conform to JESD 95-1 SPP-012.
  3. Contact plating: NiPdAu

### PCB Mounting Pattern

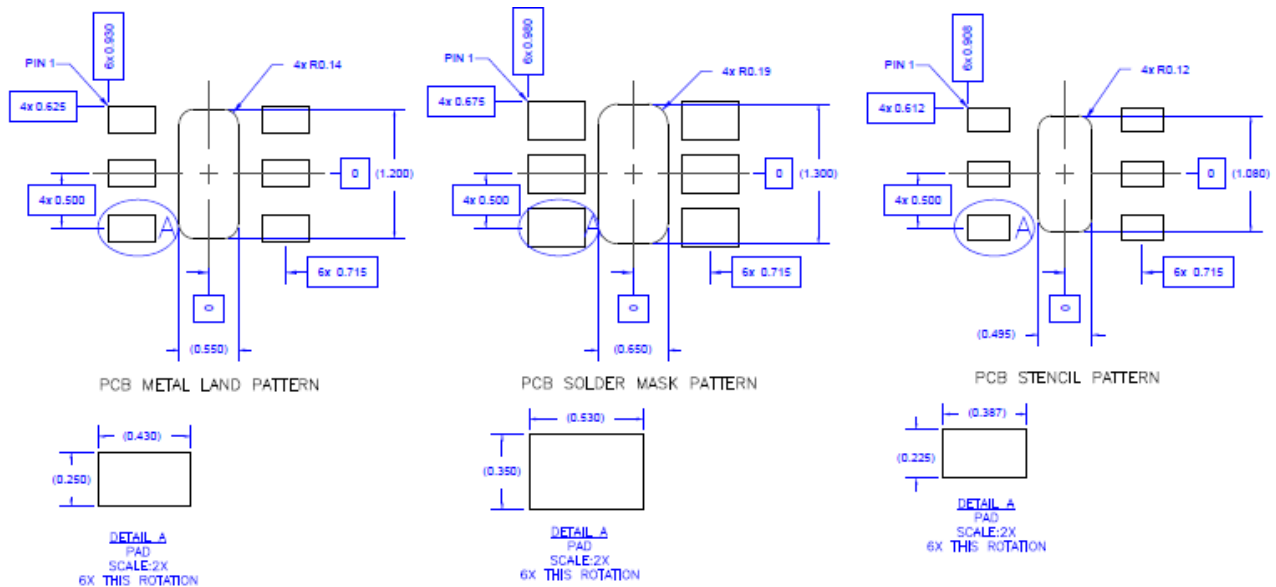

Thermal vias for center slug should be incorporated into the PCB design. The number and size of thermal vias will depend on the application, the power dissipation, and the electrical requirements. Example of the number and size of vias can be found on the evaluation board layout.

- Notes:
1. All dimensions are in millimeters. Angles are in degrees.
  2. Ensure good package backside paddle solder attach for reliable operation and best electrical performance.

### Handling Precautions

Parameter	Rating	Standard
ESD – Human Body Model (HBM)	Class 1C	ESDA / JEDEC JS-001-2012
ESD – Charged Device Model (CDM)	Class C3	JEDEC JESD22-C101F
MSL – Moisture Sensitivity Level	Level 2	IPC/JEDEC J-STD-020



Caution!  
ESD-Sensitive Device

### Solderability

Compatible with both lead-free (260°C max. reflow temp.) and tin/lead (245°C max. reflow temp.) soldering processes. Solder profiles available upon request.

Contact plating: NiPdAu

### RoHS Compliance

This part is compliant with EU 2002/95/EC RoHS directive (Restrictions on the Use of Certain Hazardous Substances in Electrical and Electronic Equipment). This product also has the following attributes:

- Lead Free
- Halogen Free (Chlorine, Bromine)
- Antimony Free
- TBBP-A (C<sub>15</sub>H<sub>12</sub>Br<sub>4</sub>O<sub>2</sub>) Free
- PFOS Free
- SVHC Free
- Qorvo Green



### Contact Information

For the latest specifications, additional product information, worldwide sales and distribution locations:

Tel: 1-844-890-8163

Web: [www.qorvo.com](http://www.qorvo.com)

Email: [customer.support@qorvo.com](mailto:customer.support@qorvo.com)

For technical questions and application information: Email: [sicapplications.engineering@qorvo.com](mailto:sicapplications.engineering@qorvo.com)

### Important Notice

The information contained herein is believed to be reliable; however, Qorvo makes no warranties regarding the information contained herein and assumes no responsibility or liability whatsoever for the use of the information contained herein. All information contained herein is subject to change without notice. Customers should obtain and verify the latest relevant information before placing orders for Qorvo products. The information contained herein or any use of such information does not grant, explicitly or implicitly, to any party any patent rights, licenses, or any other intellectual property rights, whether with regard to such information itself or anything described by such information. **THIS INFORMATION DOES NOT CONSTITUTE A WARRANTY WITH RESPECT TO THE PRODUCTS DESCRIBED HEREIN, AND QORVO HEREBY DISCLAIMS ANY AND ALL WARRANTIES WITH RESPECT TO SUCH PRODUCTS WHETHER EXPRESS OR IMPLIED BY LAW, COURSE OF DEALING, COURSE OF PERFORMANCE, USAGE OF TRADE OR OTHERWISE, INCLUDING THE IMPLIED WARRANTIES OF MERCHANTABILITY AND FITNESS FOR A PARTICULAR PURPOSE.**

Without limiting the generality of the foregoing, Qorvo products are not warranted or authorized for use as critical components in medical, life-saving, or life-sustaining applications, or other applications where a failure would reasonably be expected to cause severe personal injury or death.

Copyright 2016 © Qorvo, Inc. | Qorvo is a registered trademark of Qorvo, Inc.



Компания «ЭлектроПласт» предлагает заключение долгосрочных отношений при поставках импортных электронных компонентов на взаимовыгодных условиях!

Наши преимущества:

- Оперативные поставки широкого спектра электронных компонентов отечественного и импортного производства напрямую от производителей и с крупнейших мировых складов;
- Поставка более 17-ти миллионов наименований электронных компонентов;
- Поставка сложных, дефицитных, либо снятых с производства позиций;
- Оперативные сроки поставки под заказ (от 5 рабочих дней);
- Экспресс доставка в любую точку России;
- Техническая поддержка проекта, помощь в подборе аналогов, поставка прототипов;
- Система менеджмента качества сертифицирована по Международному стандарту ISO 9001;
- Лицензия ФСБ на осуществление работ с использованием сведений, составляющих государственную тайну;
- Поставка специализированных компонентов (Xilinx, Altera, Analog Devices, Intersil, Interpoint, Microsemi, Aeroflex, Peregrine, Syfer, Eurofarad, Texas Instrument, Miteq, Cobham, E2V, MA-COM, Hittite, Mini-Circuits, General Dynamics и др.);

Помимо этого, одним из направлений компании «ЭлектроПласт» является направление «Источники питания». Мы предлагаем Вам помощь Конструкторского отдела:

- Подбор оптимального решения, техническое обоснование при выборе компонента;
- Подбор аналогов;
- Консультации по применению компонента;
- Поставка образцов и прототипов;
- Техническая поддержка проекта;
- Защита от снятия компонента с производства.



#### Как с нами связаться

**Телефон:** 8 (812) 309 58 32 (многоканальный)

**Факс:** 8 (812) 320-02-42

**Электронная почта:** [org@eplast1.ru](mailto:org@eplast1.ru)

**Адрес:** 198099, г. Санкт-Петербург, ул. Калинина, дом 2, корпус 4, литера А.