

D5V

Contact Displacement Sensor Integrated with Amplifier Enables Inline Measurement of a Wide Range of Objects at a Low Operating Force



- Works with a low operating force (0.29 N) to detect a wide variety of objects including glass, plastic, and rubber objects.
- Models with digital output for B7A Units and models with 4- to 20-mA linear output corresponding to the 0- to 5-mm measurement range are available.
- Three types of measurement head can be selected according to the object: Ball, pin, or flat.
- The XS3 Sensor I/O Connector makes Sensor connections simple.

Ordering Information

Measurement range	Output specifications	Actuator	Resolution	Model
5 mm	4 to 20 mA	Ball type	10 μm	D5VA-3B1
		Pin type		D5VA-3P1
		Flat type *1		D5VA-3F1
	B7A serial communications output *2	Ball type	1 μm	D5VM-3B1
		Pin type		D5VM-3P1
		Flat type *1		D5VM-3F1

*1. Flat-type actuators have a hole 5-mm deep for an M2.5 screw in the tip so that an actuator can be mounted externally.

*2. Use the D5VM-3□1 in combination with the B7A Link Terminal Output Unit or a C200H or CQM1 B7A Interface Unit. Use 16- or 32-point Units with a standard transmission delay time (19.2 ms). (A high-speed type cannot be used).

Approved Standard Ratings

Conformance to EN50081-1, pr50082-2

Rated current	100 mA
Rated voltage	24 VDC

Z300

Z500

Z550

Z4D-F

Z4W-V

E4PA-N

E4DA

D5V

Ratings and Specifications

Item	Model	D5VA-3□□1	D5VM-3□□1
Power Supply voltage		12 to 24 VDC±10% *1	
Current consumption		80 mA max.	
Measurement range		5 mm	
Maximum actuator travel distance		Approx. 5.7 mm	
Offset adjustment range		±0.25 mm	
Resolution		10 μm	1 μm
Linearity		0.5% FS max.	
Repeat accuracy		10 μm max.	
Response time		6 ms max.	37 ms max. (including transmission delay time)
Operating force		0.3 N max.	
Output		Linear current output: 4 to 20 mA (Allowable load resistance: 0 to 300 Ω)	B7A serial communications output (BCD and multipoint ON/OFF output modes *2)
Mounting method		Two M4 screws	
Indicators		Power and overtravel indicators	Power, overtravel, setting, and output indicators
Mechanical durability		10,000,000 operations min.	
Temperature influence		±0.04% FS/°C max.	
Operating temperature		-10 to 55 °C (with no icing or condensation)	
Storage temperature		-25 to 65 °C (with no icing or condensation)	
Humidity range		35% to 85% (with no icing or condensation)	
Insulation resistance		100 MΩ min. (at 100 VDC)	
Dielectric strength		1,000 VAC, 50/60 Hz for 1 min	
Noise resistance		Noise level: 1.5 kV with a pulse width of 100 ns to 1 μs	
Vibration resistance		10 to 55 Hz, 0.75-mm double amplitude	
Shock resistance		196 m/s ²	
Connection cable		2 m (XS3F-M421-402-R provided)	
Weight		Approx. 80 g (without cable)	
Material		ABS and PC polymer alloy	

Displacement/
Length Sensors

Sensing
Guide

Smart
Sensors

Displacement
Sensors

Length
Sensors

Other
Information

*1. If power is supplied to both the D5VM-3□□1 and B7A Output Link Terminal from a single power supply, the supply voltage must be 24 VDC±10%.
*2. BCD or multipoint output mode can be selected with the mode selector.

Dimensions (The illustration shows the D5VA-□□□□.)

(Unit: mm)

D5VA-3B1
D5VM-3B1

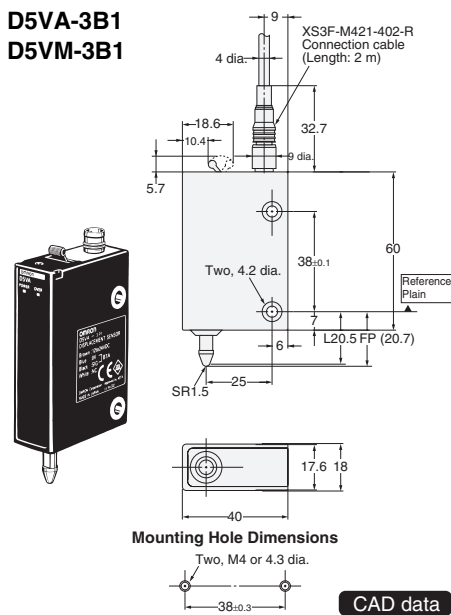

D5VA-3P1
D5VM-3P1

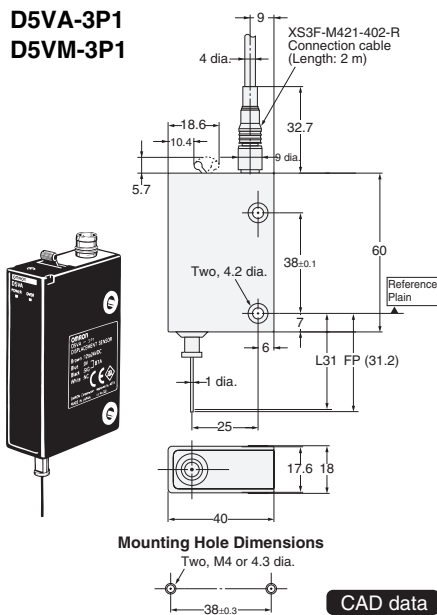

D5VA-3F1
D5VM-3F1

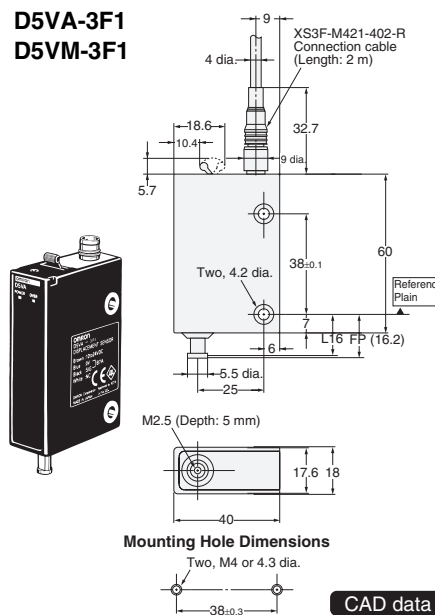

Z300
Z500
Z550
Z4D-F
Z4W-V
E4PA-N
E4DA
D5V

The output at position "L" is set at the factory to 4 mA for the D5VA, and to 0000 for the D5VM (BCD mode). In the free position (FP), EEEE is output, and when pressed in excess of the measurement range, FFFF is output.

For safety precautions and further details, refer to *Contact Displacement Sensors Series Catalog* (Cat. No. X071).

Cat. No. F802-E1-01

In the interest of product improvement, specifications are subject to change without notice.



Компания «ЭлектроПласт» предлагает заключение долгосрочных отношений при поставках импортных электронных компонентов на взаимовыгодных условиях!

Наши преимущества:

- Оперативные поставки широкого спектра электронных компонентов отечественного и импортного производства напрямую от производителей и с крупнейших мировых складов;
- Поставка более 17-ти миллионов наименований электронных компонентов;
- Поставка сложных, дефицитных, либо снятых с производства позиций;
- Оперативные сроки поставки под заказ (от 5 рабочих дней);
- Экспресс доставка в любую точку России;
- Техническая поддержка проекта, помощь в подборе аналогов, поставка прототипов;
- Система менеджмента качества сертифицирована по Международному стандарту ISO 9001;
- Лицензия ФСБ на осуществление работ с использованием сведений, составляющих государственную тайну;
- Поставка специализированных компонентов (Xilinx, Altera, Analog Devices, Intersil, Interpoint, Microsemi, Aeroflex, Peregrine, Syfer, Eurofarad, Texas Instrument, Miteq, Cobham, E2V, MA-COM, Hittite, Mini-Circuits, General Dynamics и др.);

Помимо этого, одним из направлений компании «ЭлектроПласт» является направление «Источники питания». Мы предлагаем Вам помощь Конструкторского отдела:

- Подбор оптимального решения, техническое обоснование при выборе компонента;
- Подбор аналогов;
- Консультации по применению компонента;
- Поставка образцов и прототипов;
- Техническая поддержка проекта;
- Защита от снятия компонента с производства.



Как с нами связаться

Телефон: 8 (812) 309 58 32 (многоканальный)

Факс: 8 (812) 320-02-42

Электронная почта: org@eplast1.ru

Адрес: 198099, г. Санкт-Петербург, ул. Калинина, дом 2, корпус 4, литера А.