

NCV97310MW33GEVB

NCV97310 Evaluation Board User's Manual



ON Semiconductor®

<http://onsemi.com>

EVAl BOARD USER'S MANUAL

Description

The NCV97310 is 3-output regulator consisting of a low-I_q battery-connected 3 A 2 MHz non-synchronous switcher and two low-voltage 1.5 A 2 MHz synchronous switchers; all using integrated power transistors.

The high-voltage switcher is capable of converting a 4.1 V to 18 V battery input to a 5 V or 3.3 V output at a constant 2 MHz switching frequency, delivering up to 3 A. In overvoltage conditions up to 36 V, the switching frequency folds back to 1 MHz; in load dump conditions up to 45 V the regulator shuts down.

The output of the battery-connected buck regulator serves as the low voltage input for the 2 synchronous switchers. Each downstream output is adjustable from 1.2 V to 3.3 V, with a 1.5 A current limit and a constant 2 MHz switching frequency. Each switcher has independent enable and reset pins, giving extra power management flexibility.

For low-I_q operating mode the low-voltage switchers are disabled, and the standby rail is supplied by a low-I_q LDO (up to 150 mA) with a typical I_q of 30 μA. The LDO regulator is in parallel to the high-voltage switcher, and is activated when the switcher is forced in standby mode.

All 3 SMPS outputs use peak current mode control with internal slope compensation, internally-set soft-start, battery undervoltage lockout, battery overvoltage protection, cycle-by-cycle current limiting, hiccup mode short-circuit protection and thermal shutdown. An error flag is available for diagnostics.

Key Features

- Low Quiescent Current in Standby Mode
- 2 Microcontroller Enabled Low Voltage Synchronous Buck Converters
- Large Conversion Ratio of 18 V to 3.3 V Battery Connected Switcher
- Wide Input of 4.1 to 45 V with Undervoltage Lockout (UVLO)
- Fixed Frequency Operation Adjustable from 2.0 to 2.6 MHz
- Internal 1.5 ms Soft-starts
- Cycle-by-Cycle Current Limit Protections
- Hiccup Overcurrent Protections (OCP)
- Individual Reset Pins with Adjustable Delays
- These Devices are Pb-Free, Halogen Free/BFR Free and are RoHS Compliant

Typical Applications

- Infotainment, Body Electronics, Telematics, ECU

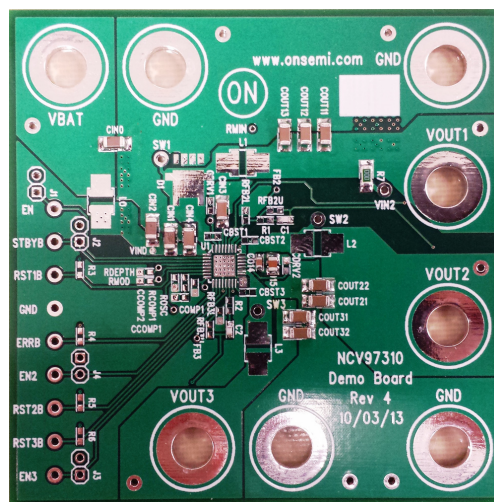

Figure 1. Evaluation Board Photo

NCV97310MW33GEVB

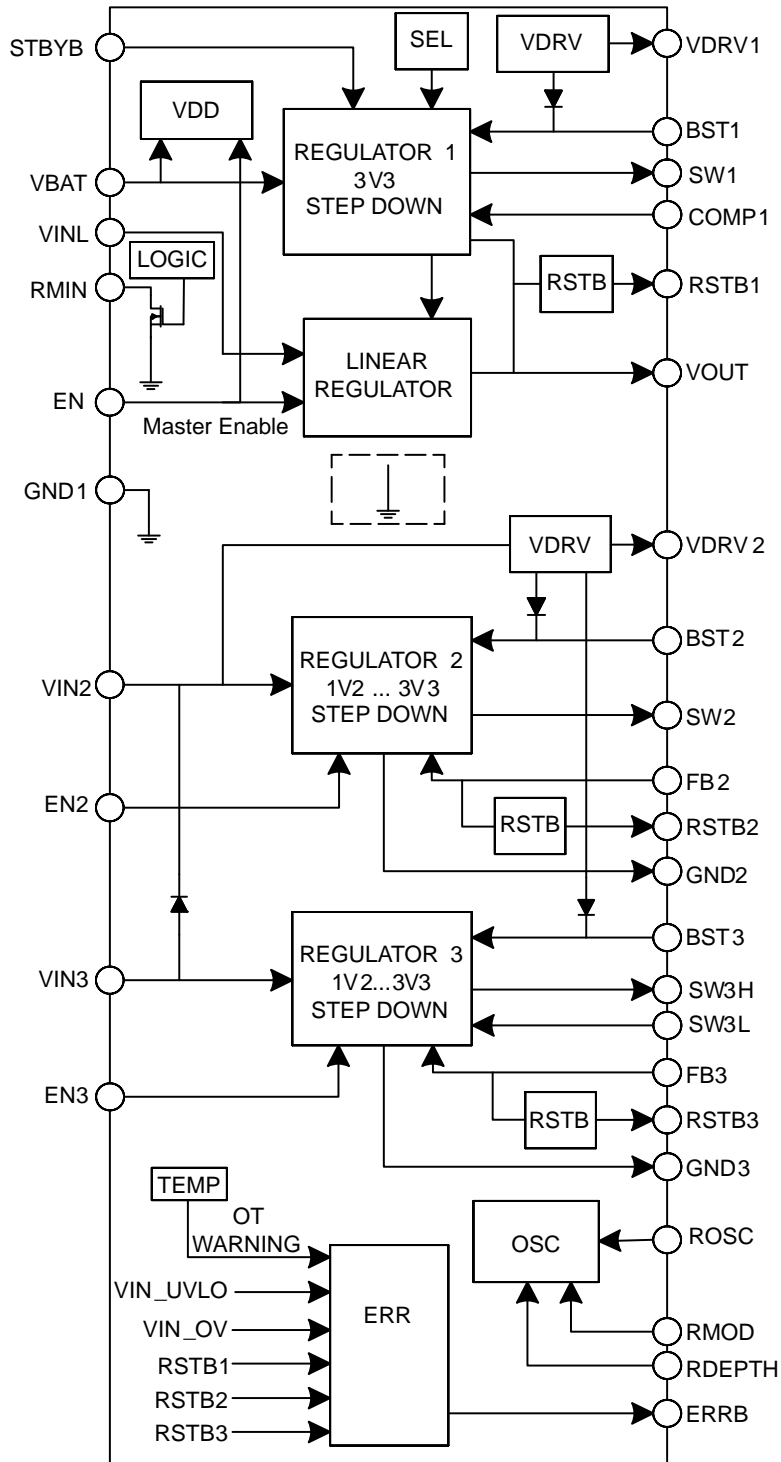

Figure 2. NCV97310 Block Diagram

NCV97310MW33GEVB

TYPICAL APPLICATION

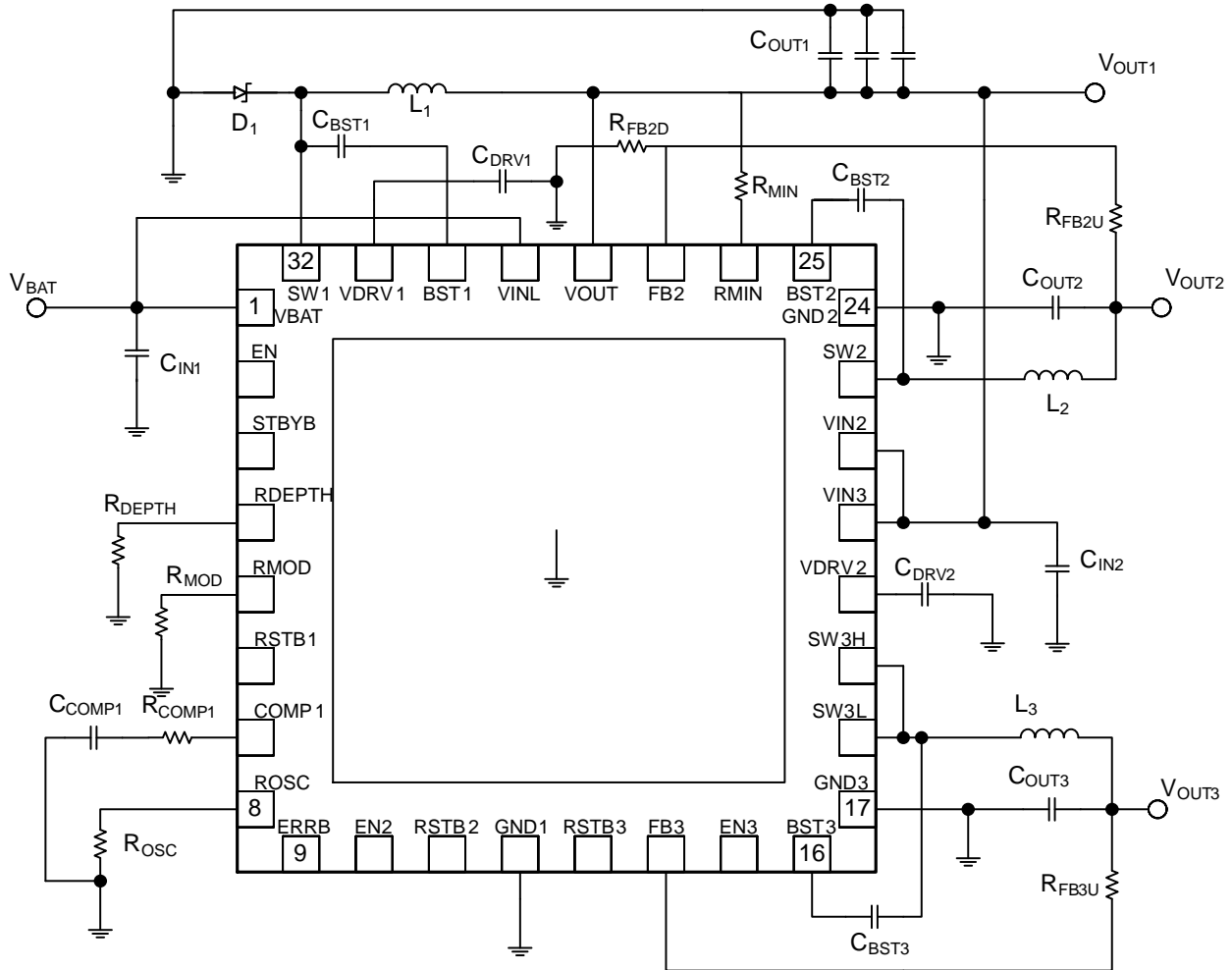

Figure 3. Typical Application

Table 1. EVALUATION BOARD TERMINALS

Pin Name	Function
VBAT	Positive dc input voltage
GND	Common dc return
VOUT1	Positive 3.3 V dc output voltage (LDO/Switcher 1)
VOUT2	Positive DC output voltage (Switcher 2)
VOUT3	Positive DC output voltage (Switcher 3)
EN	Master enable input. Includes jumper J3 to connect to VBAT.
STBYB	Standby enable input. Includes jumper J4 to connect to VBAT.
EN2	Switcher 2 enable input. Includes jumper J6 to connect to VOUT1.
EN3	Switcher 3 enable input. Includes jumper J5 to connect to VOUT1.
ERRB	Error flag combining temperature and input and output voltage sensing.
RST1B	Reset with adjustable delay. Goes low when the VOUT1 is out of regulation.
RST2B	Reset with adjustable delay. Goes low when the VOUT2 is out of regulation.
RST3B	Reset with adjustable delay. Goes low when the VOUT3 is out of regulation.

NCV97310MW33GEVB

Table 2. ABSOLUTE MAXIMUM RATINGS (Voltages are with respect to GND)

Rating	Value	Unit
Dc Supply Voltage (VBAT, EN, STBYB)	-0.3 to 36	V
Dc Supply Voltage (VIN2, VIN3)	-0.3 to 12	V
Dc Supply Voltage (RSTB1, RSTB2, RSTB3, ERRB, EN2, EN3)	-0.3 to 6	V
Storage Temperature Range	-55 to 150	°C

Stresses exceeding those listed in the Maximum Ratings table may damage the device. If any of these limits are exceeded, device functionality should not be assumed, damage may occur and reliability may be affected.

Table 3. ELECTRICAL CHARACTERISTICS (TA = 25°C, 4.5 ≤ VIN ≤ 18 V, IOU ≤ 2 A, unless otherwise specified)

Characteristic	Conditions	Typical Value	Unit
----------------	------------	---------------	------

REGULATION

Output Voltage (VOUT1)		3.3	V
Output Voltage (VOUT2)		1.8	V
Output Voltage (VOUT3)		1.2	V
Line Regulation (VOUT1)	I _{OUT1} = 1.0 A	0.03	%
Line Regulation (VOUT2)	I _{OUT2} = 1.0 A	0.01	%
Line Regulation (VOUT3)	I _{OUT3} = 1.0 A	0.001	%
Load Regulation (VOUT1)	V _{BAT} = 13.2 V	0.3	%
Load Regulation (VOUT2)	V _{BAT} = 13.2 V	0.02	%
Load Regulation (VOUT3)	V _{BAT} = 13.2 V	0.03	%

SWITCHING

Switching Frequency		2.0	MHz
Soft-start Time		1.4	ms
R _{OSC} Frequency Range	50 kΩ ≥ R _{OSC} ≥ 10 kΩ	2.0 to 2.6	MHz

CURRENT LIMIT

Peak Current Limit (VOUT1)	STBYB = 0 V	0.2	A
Peak Current Limit (VOUT1)	STBYB = 5 V	4.4	A
Peak Current Limit (VOUT2)		2.9	A
Peak Current Limit (VOUT3)		2.9	A

PROTECTION

Input Undervoltage Lockout (UVLO)	V _{BAT} Decreasing	3.9	V
Input Overvoltage Protection	V _{BAT} Increasing	36	V
Thermal Warning	T _J Rising	150	°C
Thermal Shutdown	T _J Rising	170	°C

Product parametric performance is indicated in the Electrical Characteristics for the listed test conditions, unless otherwise noted. Product performance may not be indicated by the Electrical Characteristics if operated under different conditions.

NCV97310MW33GEVB

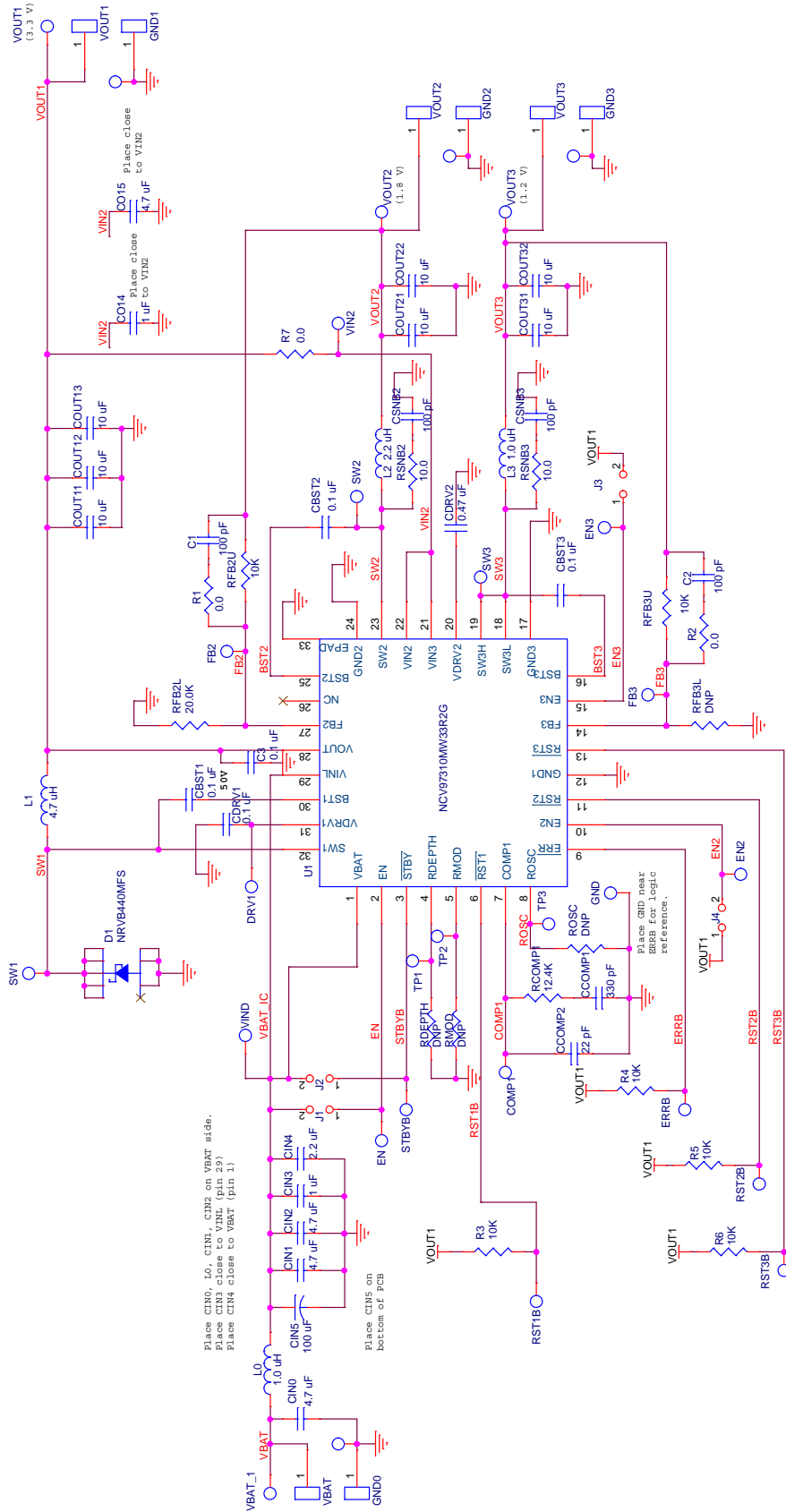

Figure 4. NCV97310GEVB 3.3 V Board Schematic

NCV97310MW33GEVB

Operational Guidelines

1. Connect a dc input voltage, within the 6.0 V to 36 V range, between VBAT and GND.
2. Connect a load (< 150 mA) between VOUT1 and GND
3. Connect a dc enable voltage, within the 2.0 V to 36 V range, between EN and GND. This will enable the internal LDO for low Iq mode. You may use jumper J1 to connect EN directly to VBAT.
 - a. The VOUT1 signal should be 3.3 V.
 - b. The VOUT2 signal should be disabled (regardless of EN2 state) and read 0 V.
 - c. The VOUT3 signal should be disabled (regardless of EN3 state) and read 0 V.
4. Connect a dc enable voltage, within the 2.0 V to 36 V range, between STBYB and GND. This will exit low Iq mode and power up switcher 1. You may use jumper J2 to connect STBYB directly to VBAT.

The VOUT1 signal should still be 3.3 V. You may now add a higher load to VOUT1.
5. Connect a dc enable voltage, within the 2.0 V to 6 V range, between EN2 and GND. This will power up switcher 2. You may use jumper J4 to connect EN2 directly to VOUT1.

The VOUT2 signal should be 1.8 V.
6. Connect a dc enable voltage, within the 2.0 V to 6 V range, between EN3 and GND. This will power up switcher 3. You may use jumper J3 to connect EN3 directly to VOUT1.

The VOUT3 signal should be 1.2 V.

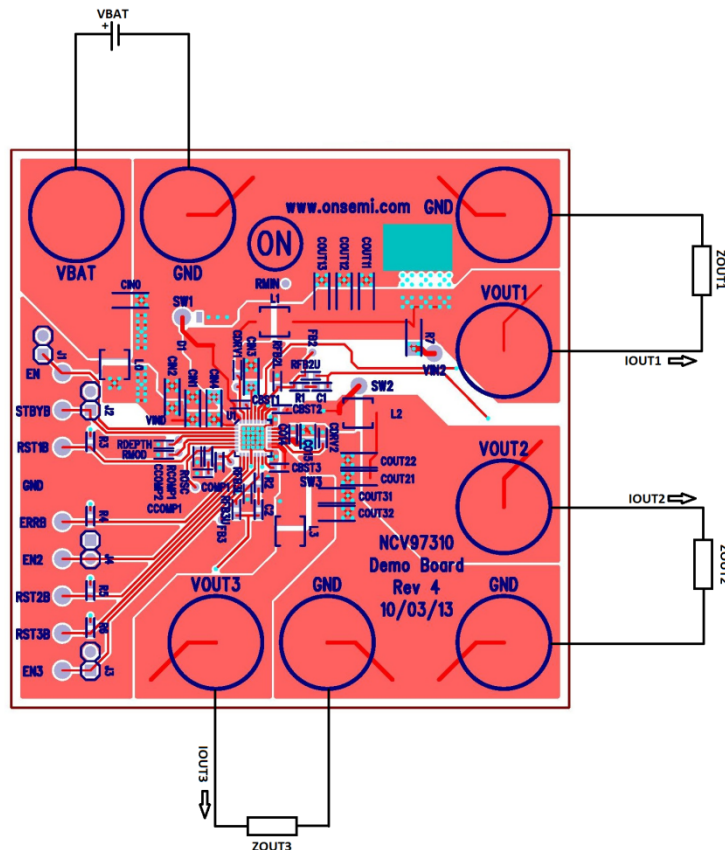
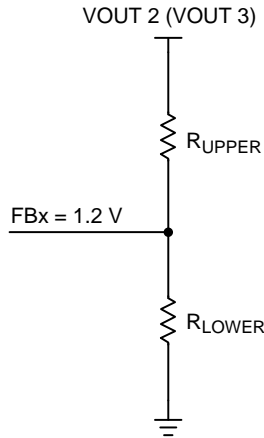

Figure 5. NCV97310 Board Connections

APPLICATION INFORMATION

Output Voltage Selection

The voltage outputs for switcher 2 and switcher 3 are adjustable and can be set with a resistor divider. The FB reference for both switchers is 1.2 V.



The upper resistor is set to 10 kΩ and is part of the feedback loop. To maintain stability over all conditions, it is recommended to change the only the lower feedback resistor to set the output voltage. Use the following equation:

$$R_{LOWER} = R_{UPPER} \frac{V_{FB}}{V_{OUT} - V_{FB}}$$

Some common setups are listed below:

Desired Output (V)	VREF (V)	R _{UPPER} (kΩ, 1%)	R _{LOWER} (kΩ, 1%)
1.2	1.2	10.0	NP
1.5	1.2	10.0	40.0
1.8	1.2	10.0	20.0
2.5	1.2	10.0	9.31
3.3	1.2	10.0	5.76

Spread Spectrum

In SMPS devices, switching translates to higher efficiency. Unfortunately, the switching leads to a much noisier EMI profile. We can greatly decrease some of the radiated emissions with some spread spectrum techniques. Spread spectrum is used to reduce the peak electromagnetic emissions of a switching regulator.

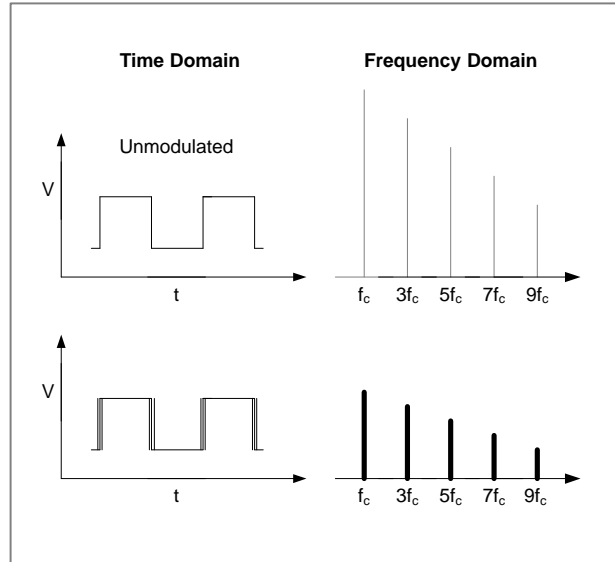

The spread spectrum used in the NCV97310 is an “up-spread” technique, meaning the switching frequency is spread upward from the 2.0 MHz base frequency. For example, a 5 % spread means that the switching frequency is swept (spread) from 2.0 MHz up to 2.1 MHz in a linear fashion – this is called the modulation depth. The rate at which this spread takes place is called the modulation frequency. For example, a 10 kHz modulation frequency means that the frequency is swept from 2.0 MHz to 2.1 MHz in 50 μs and then back down from 2.1 MHz to 2.0 MHz in 50 μs.

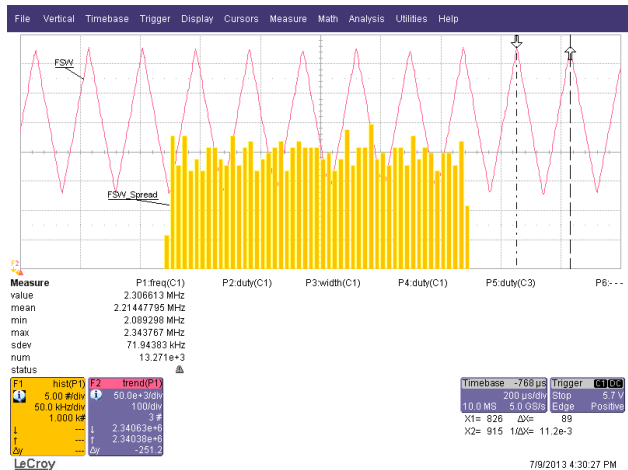

NCV97310MW33GEVB

The modulation depth and modulation frequency are each set by 2 external resistors to GND. The modulation frequency can be set from 5 kHz up to 50 kHz using a resistor from the RMOD pin to GND. The modulation depth can be set from 3% up to 30% of the nominal switching frequency using a resistor from the RDEPTH pin to GND. Please see the curves below for typical values:

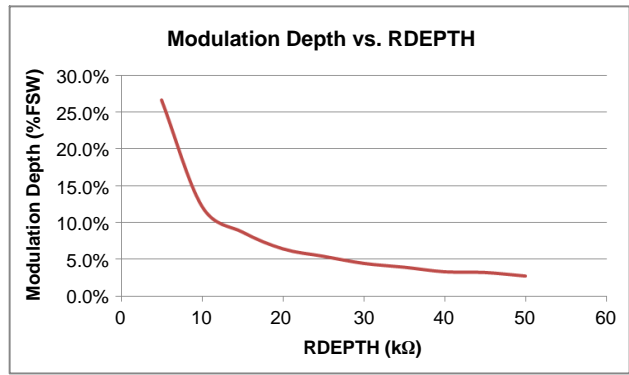
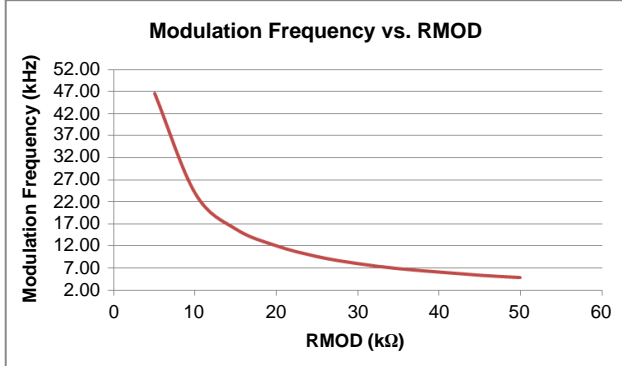

Spread spectrum is automatically turned off when there is a short to GND or an open circuit on either the RMOD pin or the RDEPTH pin. Please be sure that the ROSC pin is an open circuit when using spread spectrum.

TYPICAL PERFORMANCE

Efficiency

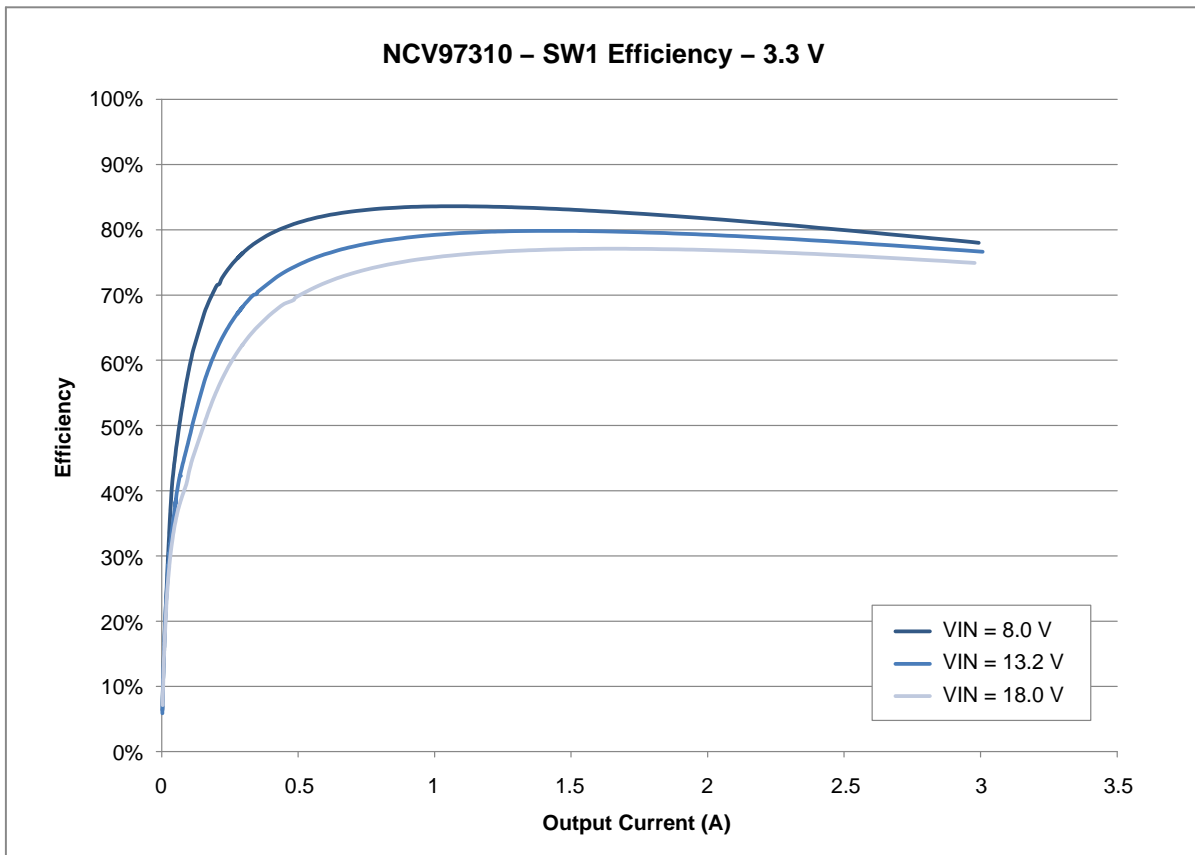

Figure 6. Efficiency for SW1 with a 3.3 V Output

NCV97310MW33GEVB

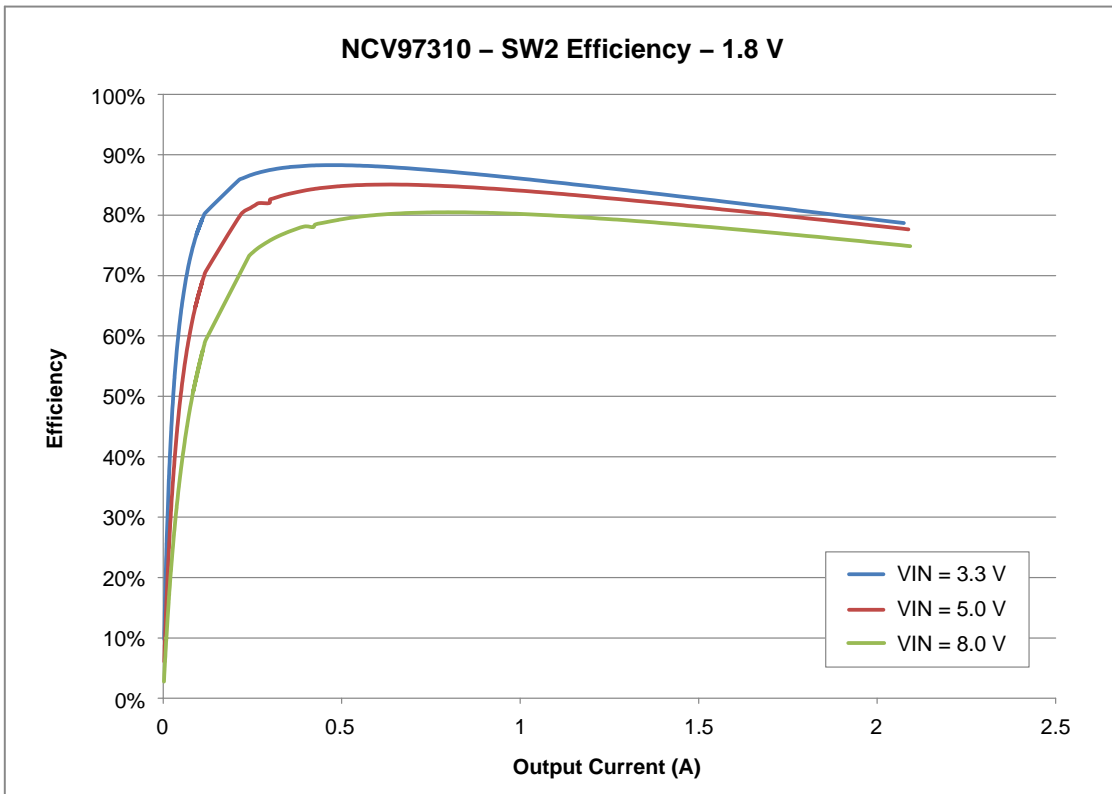

Figure 7. Efficiency for SW2 with a 1.8 V Output

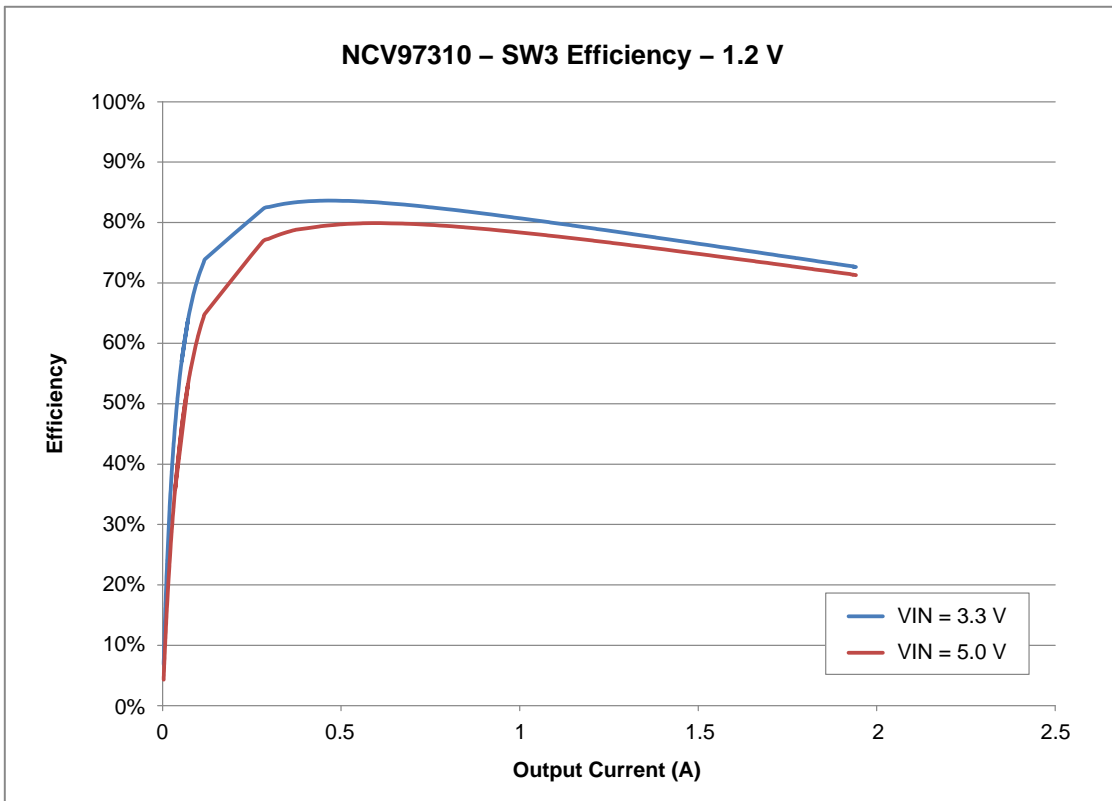

Figure 8. Efficiency for SW3 with a 1.2 V Output

NCV97310MW33GEVB

Line Regulation

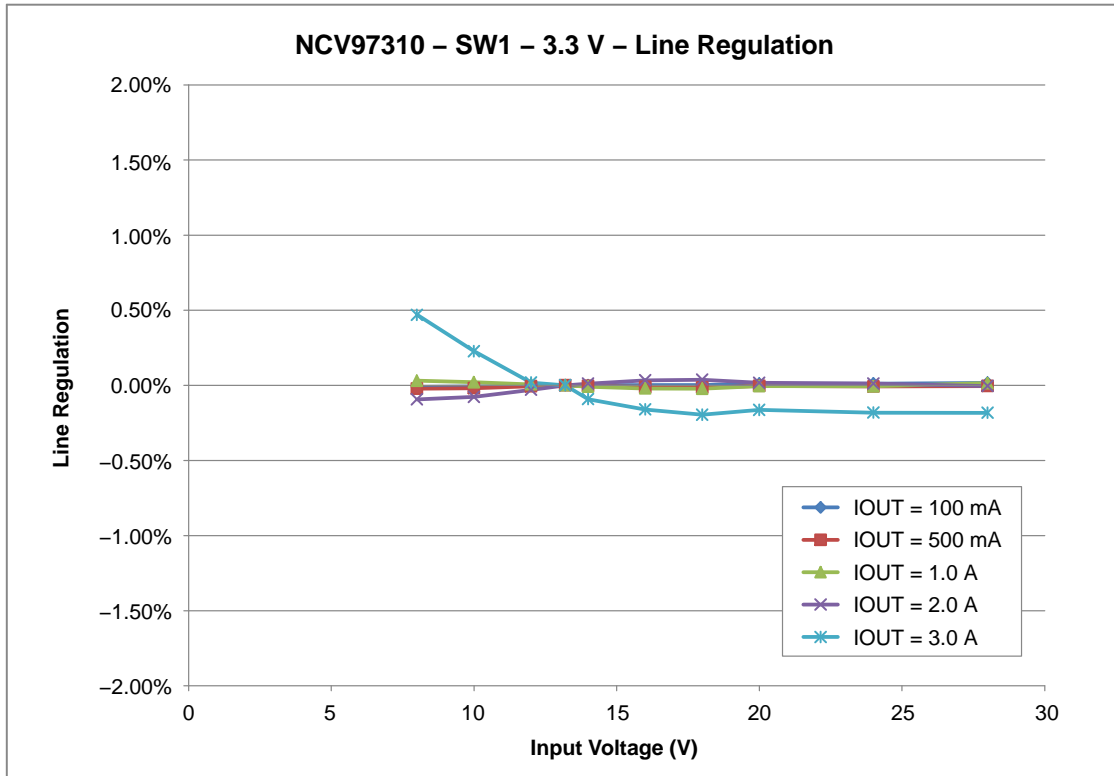

Figure 9. Line Regulation for SW1 with a 3.3 V Output

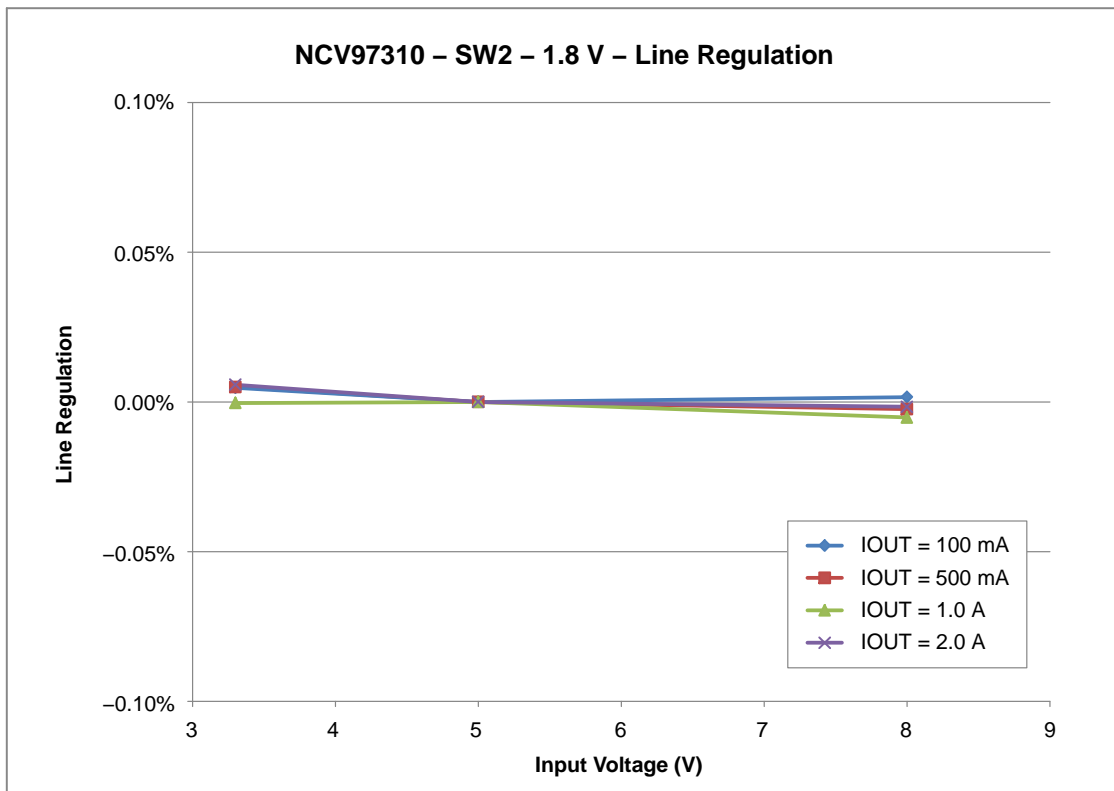

Figure 10. Line Regulation for SW2 with a 1.8 V Output

NCV97310MW33GEVB

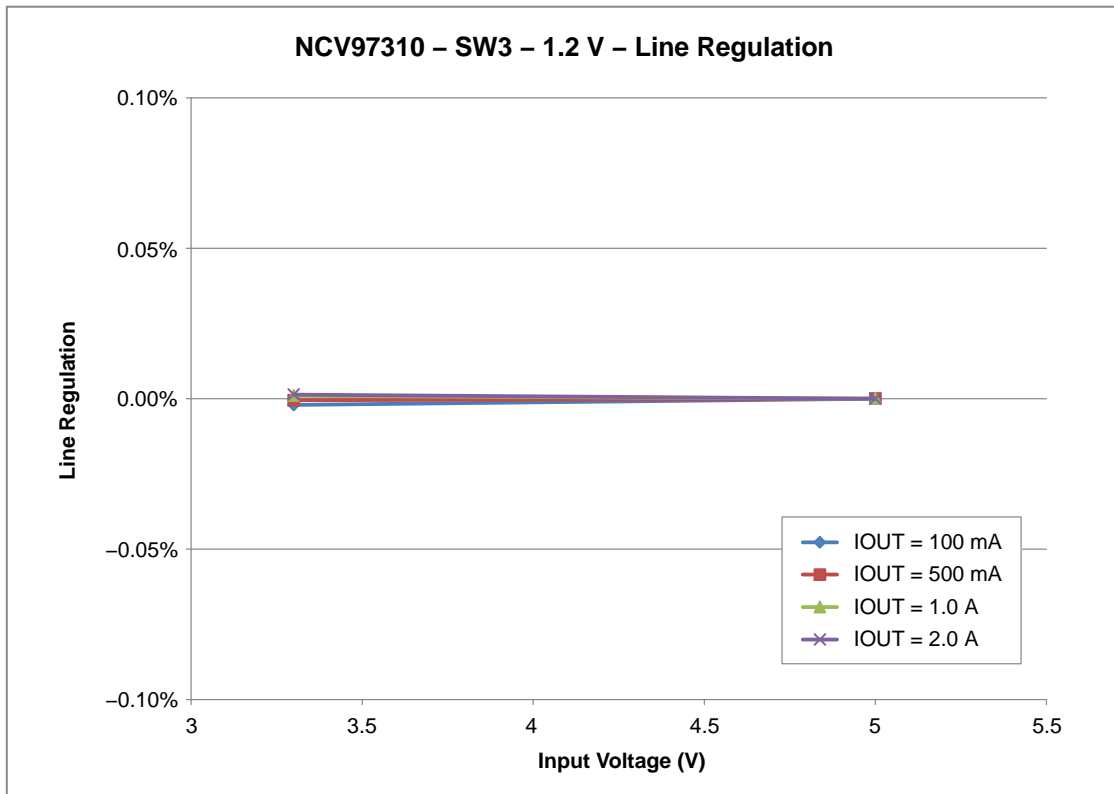

Figure 11. Line Regulation for SW3 with a 1.2 V Output

Load Regulation

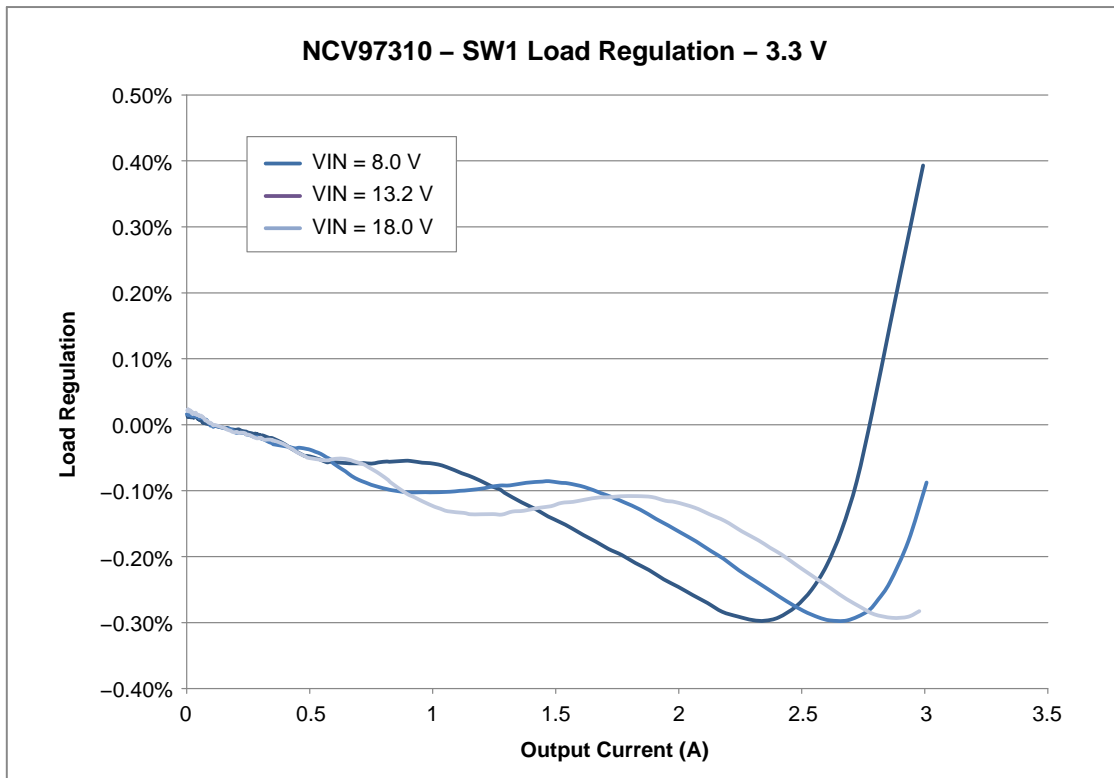

Figure 12. Load Regulation for SW1 with a 3.3 V Output

NCV97310MW33GEVB

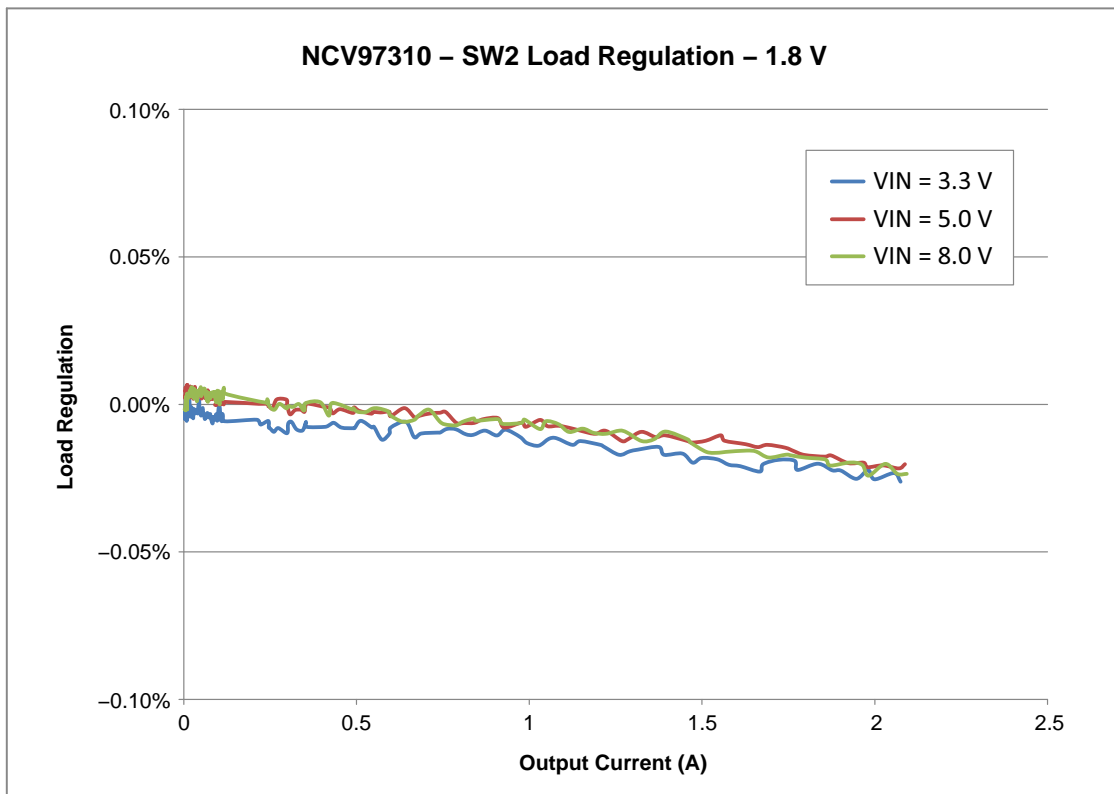

Figure 13. Load Regulation for SW2 with a 1.8 V Output

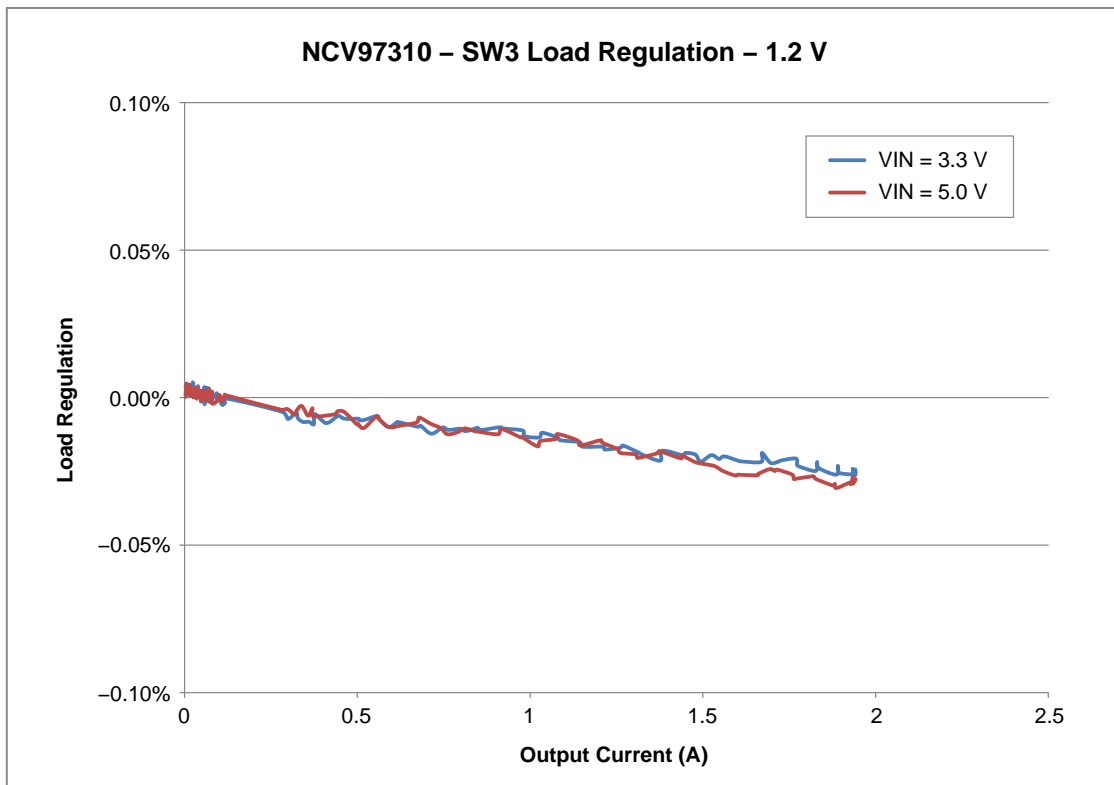
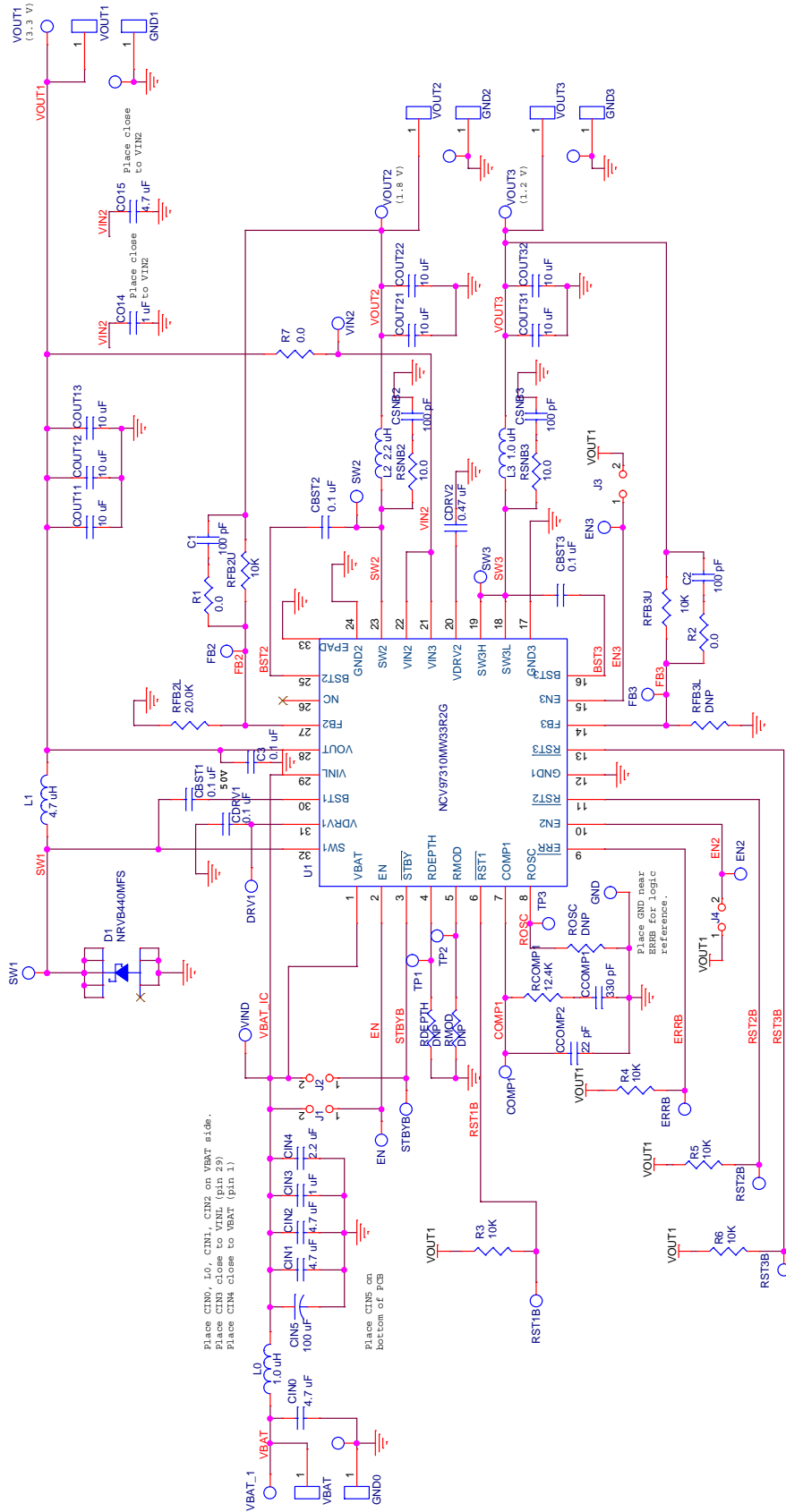

Figure 14. Load Regulation for SW3 with a 1.2 V Output

NCV97310MW33GEVB

SCHEMATIC



NCV97310MW33GEVB

PCB LAYOUT

NCV97310 Evaluation Board Rev 4 10/03/13 – TOP Layer

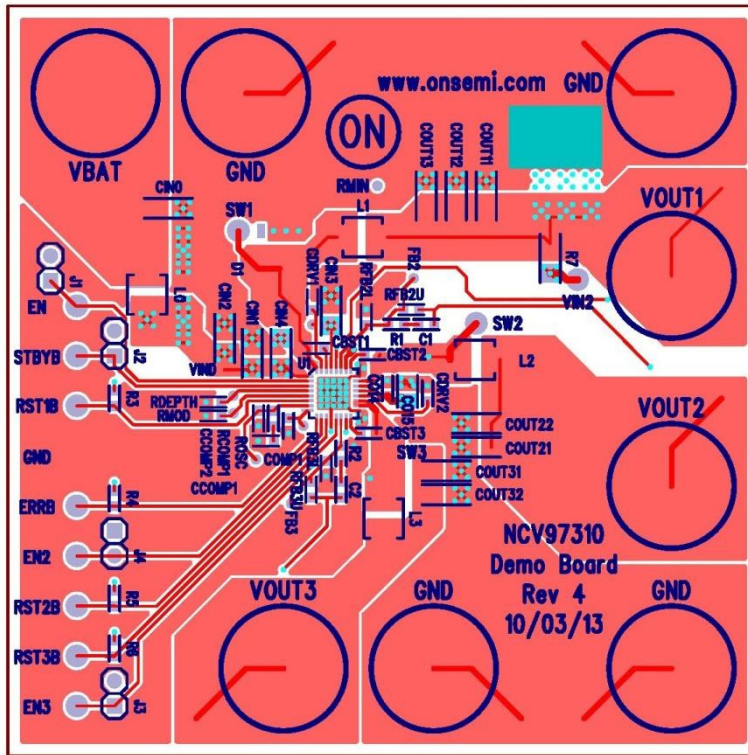

Figure 15. Top View

NCV97310 Evaluation Board Rev 4 10/03/13 – BOTTOM Layer (mirrored)

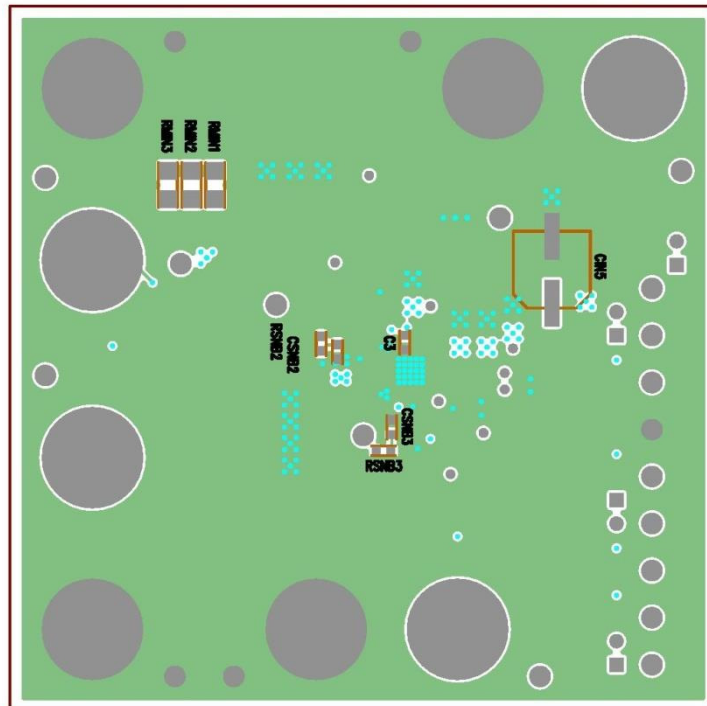

Figure 16. Bottom View

NCV97310MW33GEVB

BILL OF MATERIALS

Table 4. BILL OF MATERIALS

Reference Designator(s)	Qty.	Description	Value	Tolerance	Footprint	Manufacturer	Manufacturer's Part Number	Substitution Allowed
C1, C2, CSNB2, CSNB3	4	CAP CER 100 pF 50 V 5% NP0 0603	100 pF	5%	603	Murata Electronics North America	GCM1885C1H101JA16D	Yes
C3, CBST1, CBST2, CBST3, CDRV1	5	CAP CER 0.1 μ F 50 V 10% X7R 0603	0.1 μ F	10%	603	Murata Electronics North America	GCM188R71H104KA57D	Yes
CCOMP1	1	CAP CER 330 pF 50 V 5% NP0 0603	330 pF	5%	603	Murata Electronics North America	GCM1885C1H331JA16D	Yes
CCOMP2	1	CAP CER 22 pF 50 V 5% NP0 0603	22 pF	5%	603	Murata Electronics North America	GCM1885C1H220JA16D	Yes
CDRV2	1	CAP CER 0.47 μ F 16 V 10% X7R 0603	0.47 μ F	10%	603	Murata Electronics North America	GCM188R71C474KA55D	Yes
CIN0, CIN1, CIN2	3	CAP CER 4.7 μ F 50 V 10% X7R 1206	4.7 μ F	10%	1206	TDK Corporation	C3216X7R1H475K160AC	Yes
CIN3	1	CAP CER 1.0 μ F 50 V 10% X7R 1206	1.0 μ F	10%	1206	Murata Electronics North America	GCM31MR71H105KA55L	Yes
CIN4	1	CAP CER 2.2 μ F 50 V 10% X7R 1206	2.2 μ F	10%	1206	Murata Electronics North America	GCM31CR71H225KA55L	Yes
CIN5	1	CAP ALUM 100 μ F 50 V 20% SMD	100 μ F	20%	FK_V_E	Chemi-Con	EMZA500ADA101MHA0G	Yes
CO14	1	CAP CER 1 μ F 16 V 10% X7R 0603	1.0 μ F	10%	603	Murata Electronics North America	GCM188R71C105KA64D	Yes
CO15	1	CAP CER 4.7 μ F 16 V 10% X7R 0805	4.7 μ F	10%	805	TDK Corporation	CGA4J3X7R1C475K125AB	Yes
COUT11, COUT12, COUT13, COUT21, COUT22, COUT31, COUT32	7	CAP CER 10 μ F 10 V 10% X7R 1206	10 μ F	10%	1206	Murata Electronics North America	GCM31CR71A106KA64L	Yes
R1, R2	2	RES 0.0 Ω 1/10 W 0603 SMD	0 Ω	Jumper	603	Vishay/Dale	CRCW06030000Z0EA	Yes
R3, R4, R5, R6, RFB2U, RFB3U	6	RES 10.0 k Ω 1/10 W 1% 0603 SMD	10.0 k Ω	1%	603	Vishay/Dale	CRCW060310K0FKEA	Yes
R7	1	RES 0.0 Ω 1/4 W 1206 SMD	0 Ω	Jumper	1206	Vishay/Dale	CRCW12060000Z0EA	Yes
RCOMP1	1	RES 12.4 k Ω 1/10 W 1% 0603 SMD	12.4 k Ω	1%	603	Vishay/Dale	CRCW060312K4FKEA	Yes
RFB2L	1	RES 5.76 k Ω 1/10 W 1% 0603 SMD	5.76 k Ω	1%	603	Vishay/Dale	CRCW06035K76FKEA	Yes
RSNB2, RSNB3	2	RES 10.0 Ω 1/10 W 1% 0603 SMD	10.0 Ω	1%	603	Vishay/Dale	CRCW060310R0FKEA	Yes
D1	1	DIODE SCHOTTKY 4.0 A 40 V SMB	40 V/4.0 A	N/A	SMB_DIODE	ON Semiconductor	NRVB440MFST1G	No

NCV97310MW33GEVB

Table 4. BILL OF MATERIALS (continued)

Reference Designator(s)	Qty.	Description	Value	Tolerance	Footprint	Manufacturer	Manufacturer's Part Number	Substitution Allowed
L0, L3	2	High Current Shielded Inductor 1.0 μ H, 8.7 A SAT	1.0 μ H	20%	XAL4020-102ME	Coilcraft	XAL4020-102ME	No
L1	1	High Current Shielded Inductor 4.7 μ H, 4.5 A SAT	4.7 μ H	20%	XAL4030-472ME	Coilcraft	XAL4030-472ME	No
L2	1	High Current Shielded Inductor 2.2 μ H, 5.6 A SAT	2.2 μ H	20%	XAL4020-222ME	Coilcraft	XAL4020-222ME	No
EN, EN2, EN3, ERRB, GNDL, PGND1_1, PGND1_2, PGND2_1, PGND3_1, RST1B, RST2B, RST3B, STBYB, SW1, SW2, SW3, VIN2, VBAT, VOUT1_1, VOUT2_1, VOUT3_1	21	PIN INBOARD .042" HOLE 1000/PKG	N/A	N/A	TP	Vector Electronics	K24C/M	Yes
GND0, GND1, GND2, GND3, VBAT, VOUT1, VOUT2, VOUT3	8	CONN JACK BANANA UNINS PANEL MOU	N/A	N/A	BANANA	Emerson Network Power Connectivity Johnson	108-0740-001	No
J1, J2, J3, J4	4	CONN HEADER 2POS .100 VERT GOLD	N/A	N/A	JMP	Molex Connector Corporation	22-28-4023	Yes
	4	CONN JUMPER SHORTING GOLD	N/A	N/A	JMP	Sullins Connector Solutions	SSC02SYAN	Yes
COMP1, DRV1, FB2, FB3, RMIN, TP1, TP2, TP3, VIND	9	CIRCUIT PIN PRNTD .020"D .425"L	Do Not Populate	N/A	SMALLTP	Mill-Max Manufacturing Corp.	3128-2-00-15-00-00-08-0	Yes
RDEPTH, RFB3L, RMOD, ROSC	4		Do Not Populate		603			Yes
U1	1	Automotive Battery-Connected Low IQ Multi-Output PMU	N/A	N/A	QFN32	ON Semiconductor	NCV97310MW33R2G	No

NOTE: All devices are RoHS Compliant.

ON Semiconductor and  are registered trademarks of Semiconductor Components Industries, LLC (SCILLC). SCILLC owns the rights to a number of patents, trademarks, copyrights, trade secrets, and other intellectual property. A listing of SCILLC's product/patent coverage may be accessed at www.onsemi.com/site/pdf/Patent-Marking.pdf. SCILLC reserves the right to make changes without further notice to any products herein. SCILLC makes no warranty, representation or guarantee regarding the suitability of its products for any particular purpose, nor does SCILLC assume any liability arising out of the application or use of any product or circuit, and specifically disclaims any and all liability, including without limitation special, consequential or incidental damages. "Typical" parameters which may be provided in SCILLC data sheets and/or specifications can and do vary in different applications and actual performance may vary over time. All operating parameters, including "Typicals" must be validated for each customer application by customer's technical experts. SCILLC does not convey any license under its patent rights nor the rights of others. SCILLC products are not designed, intended, or authorized for use as components in systems intended for surgical implant into the body, or other applications intended to support or sustain life, or for any other application in which the failure of the SCILLC product could create a situation where personal injury or death may occur. Should Buyer purchase or use SCILLC products for any such unintended or unauthorized application, Buyer shall indemnify and hold SCILLC and its officers, employees, subsidiaries, affiliates, and distributors harmless against all claims, costs, damages, and expenses, and reasonable attorney fees arising out of, directly or indirectly, any claim of personal injury or death associated with such unintended or unauthorized use, even if such claim alleges that SCILLC was negligent regarding the design or manufacture of the part. SCILLC is an Equal Opportunity/Affirmative Action Employer. This literature is subject to all applicable copyright laws and is not for resale in any manner.

PUBLICATION ORDERING INFORMATION

LITERATURE FULFILLMENT:
 Literature Distribution Center for ON Semiconductor
 P.O. Box 5163, Denver, Colorado 80217 USA
Phone: 303-675-2175 or 800-344-3860 Toll Free USA/Canada
Fax: 303-675-2176 or 800-344-3867 Toll Free USA/Canada
Email: orderlit@onsemi.com

N. American Technical Support: 800-282-9855 Toll Free USA/Canada
Europe, Middle East and Africa Technical Support:
 Phone: 421 33 790 2910
Japan Customer Focus Center
 Phone: 81-3-5817-1050

ON Semiconductor Website: www.onsemi.com
Order Literature: <http://www.onsemi.com/orderlit>
 For additional information, please contact your local Sales Representative



Компания «ЭлектроПласт» предлагает заключение долгосрочных отношений при поставках импортных электронных компонентов на взаимовыгодных условиях!

Наши преимущества:

- Оперативные поставки широкого спектра электронных компонентов отечественного и импортного производства напрямую от производителей и с крупнейших мировых складов;
- Поставка более 17-ти миллионов наименований электронных компонентов;
- Поставка сложных, дефицитных, либо снятых с производства позиций;
- Оперативные сроки поставки под заказ (от 5 рабочих дней);
- Экспресс доставка в любую точку России;
- Техническая поддержка проекта, помощь в подборе аналогов, поставка прототипов;
- Система менеджмента качества сертифицирована по Международному стандарту ISO 9001;
- Лицензия ФСБ на осуществление работ с использованием сведений, составляющих государственную тайну;
- Поставка специализированных компонентов (Xilinx, Altera, Analog Devices, Intersil, Interpoint, Microsemi, Aeroflex, Peregrine, Syfer, Eurofarad, Texas Instrument, Miteq, Cobham, E2V, MA-COM, Hittite, Mini-Circuits, General Dynamics и др.);

Помимо этого, одним из направлений компании «ЭлектроПласт» является направление «Источники питания». Мы предлагаем Вам помощь Конструкторского отдела:

- Подбор оптимального решения, техническое обоснование при выборе компонента;
- Подбор аналогов;
- Консультации по применению компонента;
- Поставка образцов и прототипов;
- Техническая поддержка проекта;
- Защита от снятия компонента с производства.



Как с нами связаться

Телефон: 8 (812) 309 58 32 (многоканальный)

Факс: 8 (812) 320-02-42

Электронная почта: org@eplast1.ru

Адрес: 198099, г. Санкт-Петербург, ул. Калинина, дом 2, корпус 4, литера А.