



MICROCHIP

MCP16311/2
Synchronous Buck Converter
Evaluation Board
User's Guide

Note the following details of the code protection feature on Microchip devices:

- Microchip products meet the specification contained in their particular Microchip Data Sheet.
- Microchip believes that its family of products is one of the most secure families of its kind on the market today, when used in the intended manner and under normal conditions.
- There are dishonest and possibly illegal methods used to breach the code protection feature. All of these methods, to our knowledge, require using the Microchip products in a manner outside the operating specifications contained in Microchip's Data Sheets. Most likely, the person doing so is engaged in theft of intellectual property.
- Microchip is willing to work with the customer who is concerned about the integrity of their code.
- Neither Microchip nor any other semiconductor manufacturer can guarantee the security of their code. Code protection does not mean that we are guaranteeing the product as "unbreakable."

Code protection is constantly evolving. We at Microchip are committed to continuously improving the code protection features of our products. Attempts to break Microchip's code protection feature may be a violation of the Digital Millennium Copyright Act. If such acts allow unauthorized access to your software or other copyrighted work, you may have a right to sue for relief under that Act.

Information contained in this publication regarding device applications and the like is provided only for your convenience and may be superseded by updates. It is your responsibility to ensure that your application meets with your specifications. MICROCHIP MAKES NO REPRESENTATIONS OR WARRANTIES OF ANY KIND WHETHER EXPRESS OR IMPLIED, WRITTEN OR ORAL, STATUTORY OR OTHERWISE, RELATED TO THE INFORMATION, INCLUDING BUT NOT LIMITED TO ITS CONDITION, QUALITY, PERFORMANCE, MERCHANTABILITY OR FITNESS FOR PURPOSE. Microchip disclaims all liability arising from this information and its use. Use of Microchip devices in life support and/or safety applications is entirely at the buyer's risk, and the buyer agrees to defend, indemnify and hold harmless Microchip from any and all damages, claims, suits, or expenses resulting from such use. No licenses are conveyed, implicitly or otherwise, under any Microchip intellectual property rights.

Trademarks

The Microchip name and logo, the Microchip logo, dsPIC, FlashFlex, KEELOQ, KEELOQ logo, MPLAB, PIC, PICmicro, PICSTART, PIC³² logo, rPIC, SST, SST Logo, SuperFlash and UNI/O are registered trademarks of Microchip Technology Incorporated in the U.S.A. and other countries.

FilterLab, Hampshire, HI-TECH C, Linear Active Thermistor, MTP, SEEVAL and The Embedded Control Solutions Company are registered trademarks of Microchip Technology Incorporated in the U.S.A.

Silicon Storage Technology is a registered trademark of Microchip Technology Inc. in other countries.

Analog-for-the-Digital Age, Application Maestro, BodyCom, chipKIT, chipKIT logo, CodeGuard, dsPICDEM, dsPICDEM.net, dsPICworks, dsSPEAK, ECAN, ECONOMONITOR, FanSense, HI-TIDE, In-Circuit Serial Programming, ICSP, Mindi, MiWi, MPASM, MPF, MPLAB Certified logo, MPLIB, MPLINK, mTouch, Omniscent Code Generation, PICC, PICC-18, PICDEM, PICDEM.net, PICkit, PICtail, REAL ICE, rLAB, Select Mode, SQI, Serial Quad I/O, Total Endurance, TSHARC, UniWinDriver, WiperLock, ZENA and Z-Scale are trademarks of Microchip Technology Incorporated in the U.S.A. and other countries.

SQTP is a service mark of Microchip Technology Incorporated in the U.S.A.

GestIC and ULPP are registered trademarks of Microchip Technology Germany II GmbH & Co. KG, a subsidiary of Microchip Technology Inc., in other countries.

All other trademarks mentioned herein are property of their respective companies.

© 2013, Microchip Technology Incorporated, Printed in the U.S.A., All Rights Reserved.

 Printed on recycled paper.

ISBN: 978-1-62077-772-5

**QUALITY MANAGEMENT SYSTEM
CERTIFIED BY DNV
= ISO/TS 16949 =**

Microchip received ISO/TS-16949:2009 certification for its worldwide headquarters, design and wafer fabrication facilities in Chandler and Tempe, Arizona; Gresham, Oregon and design centers in California and India. The Company's quality system processes and procedures are for its PIC[®] MCUs and dsPIC[®] DSCs, KEELOQ[®] code hopping devices, Serial EEPROMs, microperipherals, nonvolatile memory and analog products. In addition, Microchip's quality system for the design and manufacture of development systems is ISO 9001:2000 certified.

**Object of Declaration: MCP16311/2 Synchronous Buck Converter Evaluation Board
User's Guide**

EU Declaration of Conformity

This declaration of conformity is issued by the manufacturer.

The development/evaluation tool is designed to be used for research and development in a laboratory environment. This development/evaluation tool is not a Finished Appliance, nor is it intended for incorporation into Finished Appliances that are made commercially available as single functional units to end users under EU EMC Directive 2004/108/EC and as supported by the European Commission's Guide for the EMC Directive 2004/108/EC (8th February 2010).

This development/evaluation tool complies with EU RoHS2 Directive 2011/65/EU.

For information regarding the exclusive, limited warranties applicable to Microchip products, please see Microchip's standard terms and conditions of sale, which are printed on our sales documentation and available at www.microchip.com.

Signed for and on behalf of Microchip Technology Inc. at Chandler, Arizona, USA

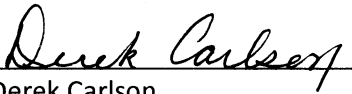

Derek Carlson

VP Development Tools

16-July-2013

Date

NOTES:



MCP16311/2 SYNCHRONOUS BUCK CONVERTER EVALUATION BOARD USER'S GUIDE

Table of Contents

Preface	7
Introduction.....	7
Document Layout	7
Conventions Used in this Guide	8
Recommended Reading.....	9
The Microchip Web Site	9
Customer Support	9
Document Revision History	9
Chapter 1. Product Overview	
1.1 Introduction	11
1.2 What is the MCP16311/2 Synchronous Buck Converter Evaluation Board?	12
1.3 What the MCP16311/2 Synchronous Buck Converter Evaluation Board Contains	12
Chapter 2. Installation and Operation	
2.1 Introduction	13
2.2 Board Features	14
2.3 Getting Started	14
Appendix A. Schematic and Layouts	
A.1 Introduction	17
A.2 Board – Schematic	18
A.3 Board – Top Silk	19
A.4 Board – Top Copper	19
A.5 Board – Top Copper and Silk	20
A.6 Board – Bottom Copper	20
Appendix B. Bill of Materials (BOM)	
Worldwide Sales and Service	22

NOTES:



MCP16311/2 SYNCHRONOUS BUCK CONVERTER EVALUATION BOARD USER'S GUIDE

Preface

NOTICE TO CUSTOMERS

All documentation becomes dated, and this manual is no exception. Microchip tools and documentation are constantly evolving to meet customer needs, so some actual dialogs and/or tool descriptions may differ from those in this document. Please refer to our web site (www.microchip.com) to obtain the latest documentation available.

Documents are identified with a “DS” number. This number is located on the bottom of each page, in front of the page number. The numbering convention for the DS number is “DSXXXXA”, where “XXXX” is the document number and “A” is the revision level of the document.

For the most up-to-date information on development tools, see the MPLAB® IDE online help. Select the Help menu, and then Topics to open a list of available online help files.

INTRODUCTION

This chapter contains general information that will be useful to know before using the MCP16311/2 Synchronous Buck Converter Evaluation Board. Items discussed in this chapter include:

- Document Layout
- Conventions Used in this Guide
- Recommended Reading
- The Microchip Web Site
- Customer Support
- Document Revision History

DOCUMENT LAYOUT

This document describes how to use the MCP16311/2 Synchronous Buck Converter Evaluation Board as a development tool. The manual layout is as follows:

- **Chapter 1. “Product Overview”** – Important information about the MCP16311/2 Synchronous Buck Converter Evaluation Board.
- **Chapter 2. “Installation and Operation”** – Includes instructions on how to get started with this user’s guide and a description of the user’s guide.
- **Appendix A. “Schematic and Layouts”** – Shows the schematic and layout diagrams for the MCP16311/2 Synchronous Buck Converter Evaluation Board.
- **Appendix B. “Bill of Materials (BOM)”** – Lists the parts used to build the MCP16311/2 Synchronous Buck Converter Evaluation Board.

CONVENTIONS USED IN THIS GUIDE

This manual uses the following documentation conventions:

DOCUMENTATION CONVENTIONS

Description	Represents	Examples
Arial font:		
Italic characters	Referenced books	<i>MPLAB[®] IDE User's Guide</i>
	Emphasized text	...is the <i>only</i> compiler...
Initial caps	A window	the Output window
	A dialog	the Settings dialog
	A menu selection	select Enable Programmer
Quotes	A field name in a window or dialog	"Save project before build"
Underlined, italic text with right angle bracket	A menu path	<u><i>File>Save</i></u>
Bold characters	A dialog button	Click OK
	A tab	Click the Power tab
N'Rnnnn	A number in verilog format, where N is the total number of digits, R is the radix and n is a digit.	4'b0010, 2'hF1
Text in angle brackets < >	A key on the keyboard	Press <Enter>, <F1>
Courier New font:		
Plain Courier New	Sample source code	#define START
	Filenames	autoexec.bat
	File paths	c:\mcc18\h
	Keywords	_asm, _endasm, static
	Command-line options	-Opa+, -Opa-
	Bit values	0, 1
	Constants	0xFF, 'A'
Italic Courier New	A variable argument	<i>file.o</i> , where <i>file</i> can be any valid filename
Square brackets []	Optional arguments	mcc18 [options] <i>file</i> [options]
Curly brackets and pipe character: { }	Choice of mutually exclusive arguments; an OR selection	errorlevel {0 1}
Ellipses...	Replaces repeated text	var_name [, var_name...]
	Represents code supplied by user	void main (void) { ... }

RECOMMENDED READING

This user's guide describes how to use the MCP16311/2 Synchronous Buck Converter Evaluation Board. Another useful document is listed below. The following Microchip document is available and recommended as a supplemental reference resource.

- **MCP16311/2 Data Sheet – “30V Input, 1A Output, High-Efficiency, Integrated Synchronous Switch Step-Down Regulator” (DS20005254)**

This data sheet provides detailed information regarding the MCP16311/2 device.

THE MICROCHIP WEB SITE

Microchip provides online support via our web site at www.microchip.com. This web site is used as a means to make files and information easily available to customers. Accessible by using your favorite Internet browser, the web site contains the following information:

- **Product Support** – Data sheets and errata, application notes and sample programs, design resources, user's guides and hardware support documents, latest software releases and archived software
- **General Technical Support** – Frequently Asked Questions (FAQs), technical support requests, online discussion groups, Microchip consultant program member listing
- **Business of Microchip** – Product selector and ordering guides, latest Microchip press releases, listing of seminars and events, listings of Microchip sales offices, distributors and factory representatives

CUSTOMER SUPPORT

Users of Microchip products can receive assistance through several channels:

- Distributor or Representative
- Local Sales Office
- Field Application Engineer (FAE)
- Technical Support

Customers should contact their distributor, representative or field application engineer (FAE) for support. Local sales offices are also available to help customers. A listing of sales offices and locations is included in the back of this document.

Technical support is available through the web site at:
<http://www.microchip.com/support>.

DOCUMENT REVISION HISTORY

Revision A (December 2013)

- Initial Release of this Document.

NOTES:

Chapter 1. Product Overview

1.1 INTRODUCTION

The MCP16311/2 is a compact, high-efficiency, fixed-frequency, step-down DC-DC converter. The integrated features include a high-side and a low-side switch, fixed frequency, internal compensation, peak current limit and overtemperature protection. This product provides an easy-to-use power supply solution, with a minimum number of external components.

The MCP16311 automatically selects the best operating mode for efficiency, Pulse-Width Modulation (PWM) or Pulse Frequency Modulation (PFM), while the MCP16312 is a PWM-only device. The MCP16311/2 family of devices have a wide input voltage range (4V to 30V) and a wide output voltage range (2V – 15V). An integrated, precise 0.8V reference, combined with an external resistor divider, sets the desired converter output voltage. The internal reference voltage is controlled during start-up, minimizing the output voltage overshoot and the inrush current.

The device is available in 8LD MSOP and 2 x 3 mm TDFN packages.

The scope of this evaluation board is to demonstrate the features of the MCP16311/2.

This chapter provides an overview of the MCP16311/2 Synchronous Buck Converter Evaluation Board and covers the following topics:

- What is the MCP16311/2 Synchronous Buck Converter Evaluation Board?
- What the MCP16311/2 Synchronous Buck Converter Evaluation Board Contains

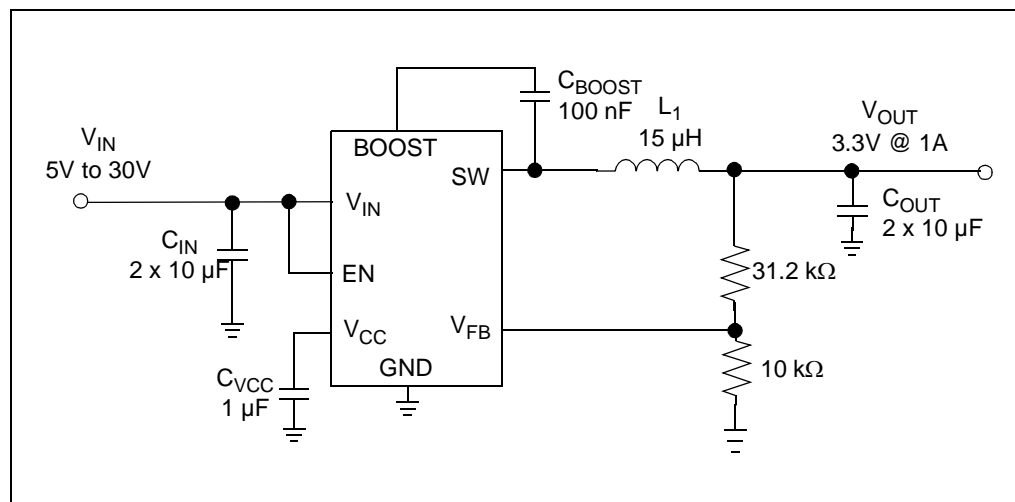

FIGURE 1-1: Typical MCP16311/2 Buck Converter Application.

1.2 WHAT IS THE MCP16311/2 SYNCHRONOUS BUCK CONVERTER EVALUATION BOARD?

The MCP16311/2 Synchronous Buck Converter Evaluation Board is used to evaluate and demonstrate Microchip Technology's MCP16311/2 product. This board demonstrates the MCP16311 (PFM/PWM – low quiescent current) and the MCP16312 (PWM only – low output voltage ripple) in two buck converter applications with two output voltages. It can be used to evaluate both package options, 8LD MSOP and 8LD 2 x 3 TDFN. The MCP16311/2 Synchronous Buck Converter Evaluation Board was developed to help engineers reduce the product design cycle time.

Two common output voltages can be selected: 3.3V and 5.0V. The first converter with the 8LD MSOP package is a PWM/PFM device with a fixed output of 3.3V, while the second converter with the 2 x 3 8LD TDFN package is a PWM-only device, with a fixed output of 5V.

1.3 WHAT THE MCP16311/2 SYNCHRONOUS BUCK CONVERTER EVALUATION BOARD CONTAINS

The MCP16311/2 Synchronous Buck Converter Evaluation Board kit includes:

- MCP16311/2 Synchronous Buck Converter Evaluation Board (ADM00467)
- Important Information Sheet

Chapter 2. Installation and Operation

2.1 INTRODUCTION

The MCP16311/2 device is capable of regulating the output voltage over a wide 2V to 15V range, and typically can deliver over 1A of load current at 3.3V output when supplied from a 12V input. The input voltage range is 4V to 30V. The regulated output voltage (V_{OUT}) should be lower than the input voltage (V_{IN}).

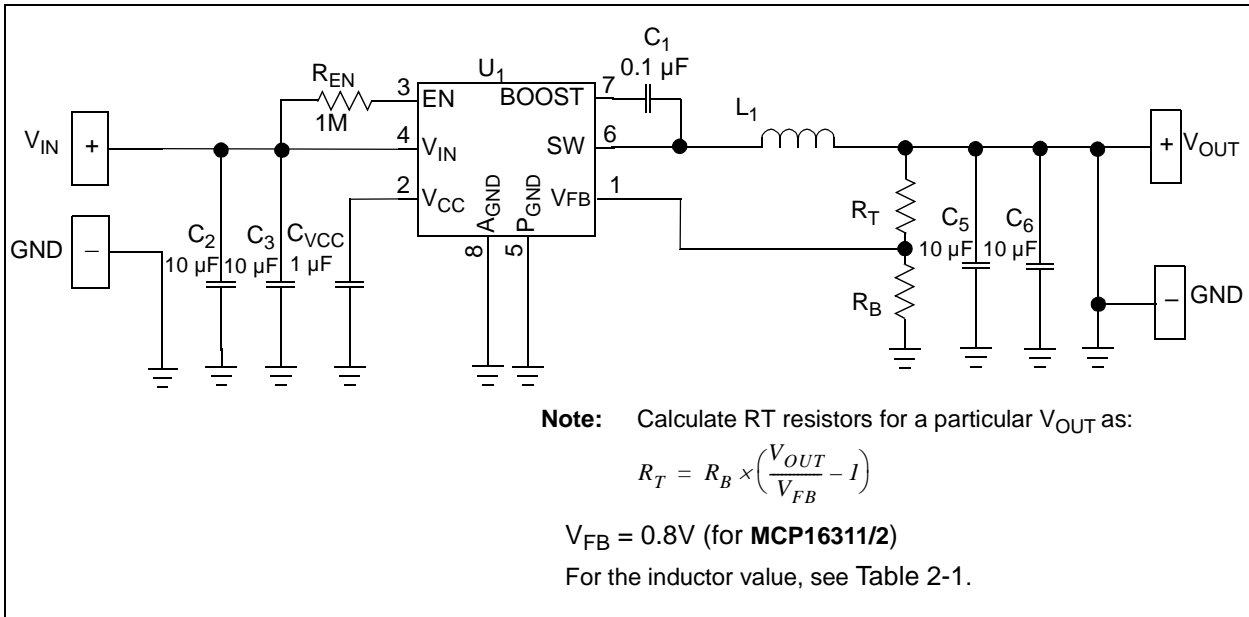

FIGURE 2-1: MCP16311/2 Synchronous Buck Typical Application.

The MCP16311/2 Synchronous Buck Converter Evaluation Board offers both package types in two buck-converter applications for 3.3V and 5.0V output voltage options. The output voltage can be modified by changing the resistors in the feedback loop based on the formula in Figure 2-1.

2.2 BOARD FEATURES

The MCP16311/2 Synchronous Buck Converter Evaluation Board has the following features:

- Input Voltage Range (V_{IN}): 4V to 30V
- Fixed Output Voltage: 3.3V and 5.0V
- Output Current: typically 1A @ 3.3V Output, 12V Input
- Automatic PFM/PWM Operation for MCP16311, or PWM-only for MCP16312
- PWM Switching Frequency: 500 kHz
- Internal Compensation
- Internal Soft Start
- Overtemperature protection (if the die temperature exceeds +150°C, 25°C hysteresis)

2.3 GETTING STARTED

The MCP16311/2 Synchronous Buck Converter Evaluation Board is fully assembled and tested to evaluate and demonstrate the MCP16311/2 products. This board requires the use of external lab supplies and load.

2.3.1 Power Input and Output Connection

2.3.1.1 POWERING THE MCP16311/2 SYNCHRONOUS BUCK CONVERTER EVALUATION BOARD

The evaluation board has two independent circuit applications. One uses the MCP16311 in the 8LD MSOP package, the other uses the MCP16312 device in the 8LD TDFN package. The 8LD MSOP package has an output voltage setting of 3.3V. The 8LD TDFN package has an output voltage setting of 5.0V.

The switch peak current limit will provide a safe maximum current value. The maximum output current for the converters will vary with input and output voltages. Refer to the MCP16311/2 data sheet for more information on the maximum output current.

2.3.1.2 BOARD POWER-UP PROCEDURE

1. Connect power supply at input. Input voltage should be higher than V_{OUT} . Connect system load to V_{OUT} and GND terminals; maximum load varies with input and output voltage (see the MCP16311/2 data sheet for more information on the maximum load). Connect the (+) side of the load to V_{OUT} and the (-) load to GND terminals.
2. By default, the EN pin is pulled high through a resistor, so the converter is enabled and V_{OUT} can be measured between V_{OUT} and GND terminals. When EN is pulled low, the converter is disabled and V_{OUT} is floating and disconnected from the input.
3. The measured output voltage should be 3.3V/5V. Adjusting the input voltage and load should not cause the output to vary more than a few mV over the operating range of the converter.

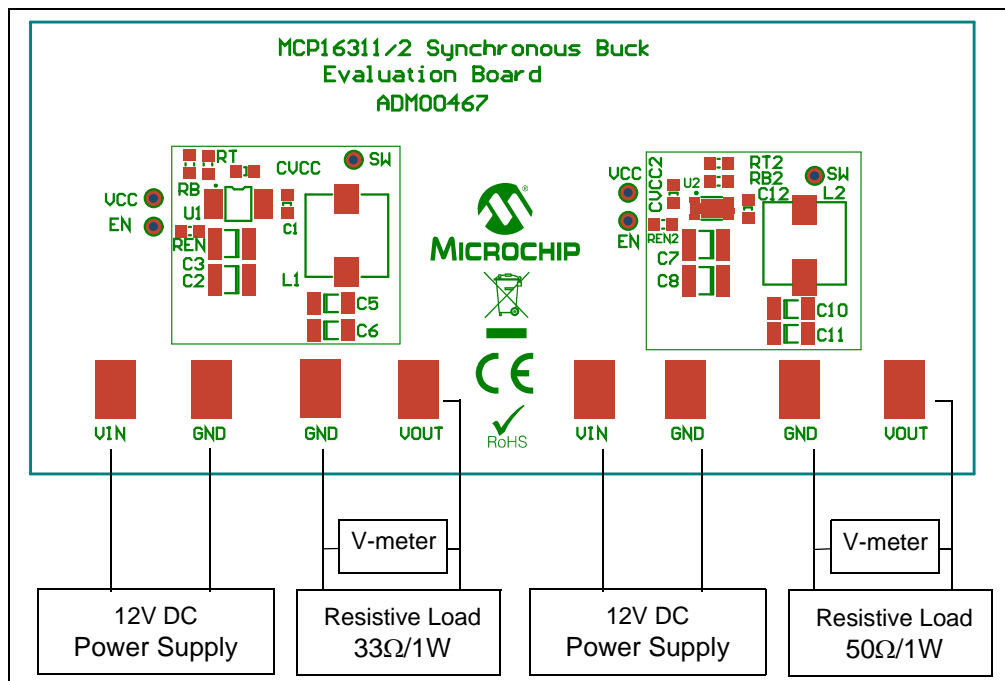

FIGURE 2-2: MCP16311/2 Synchronous Buck Converter Evaluation Board Setup.

2.3.1.3 ADJUSTABLE V_{OUT} SETTING

The resistor divider R_T and R_B are used to set the converter output voltage. If the output voltage is modified by changing the feedback resistors, the inductor should also be changed. Check Table 2-1 for the value of the inductor or the MCP16311/2 data sheet for more information. The output voltage can be calculated using the following equation:

$$R_T = R_B \times \left[\left(\frac{V_{OUT}}{V_{FB}} \right) - 1 \right]$$

Where:
 $V_{FB} = 0.8V$

TABLE 2-1: RECOMMENDED INDUCTOR VALUES

V_{OUT}	Inductor Value
2.0V	10 μH
3.3V	15 μH
5.0V	22 μH
12V	56 μH
15V	68 μH

NOTES:



MCP16311/2 SYNCHRONOUS BUCK CONVERTER EVALUATION BOARD USER'S GUIDE

Appendix A. Schematic and Layouts

A.1 INTRODUCTION

This appendix contains the following schematics and layouts for the MCP16311/2 Synchronous Buck Converter Evaluation Board:

- Board – Schematic
- Board – Top Silk
- Board – Top Copper
- Board – Top Copper and Silk
- Board – Bottom Copper

A.2 BOARD – SCHEMATIC

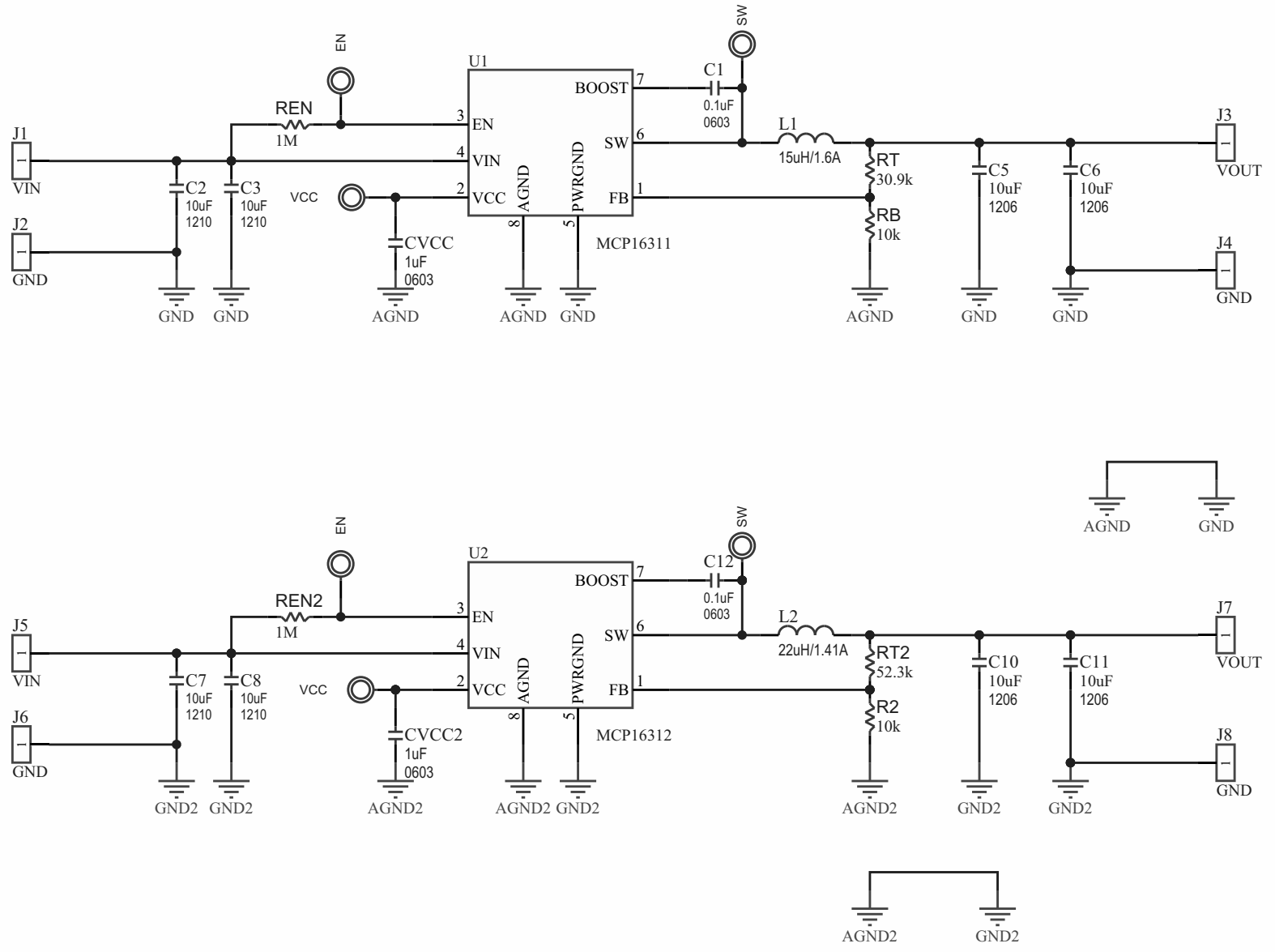

A.3 BOARD – TOP SILK

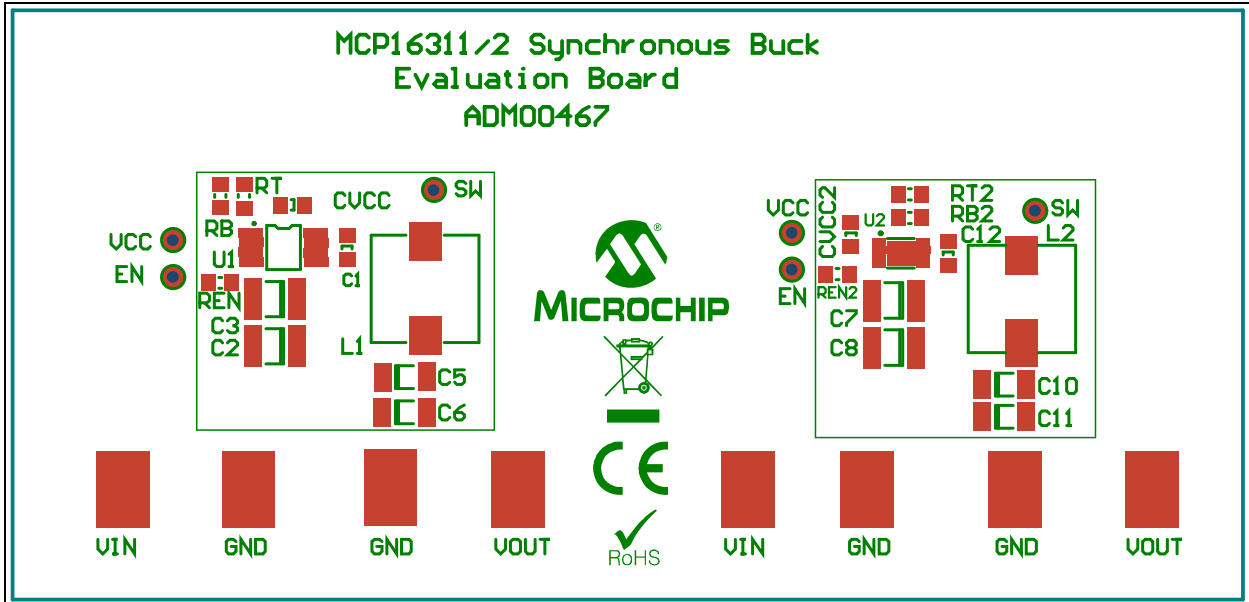

A.4 BOARD – TOP COPPER

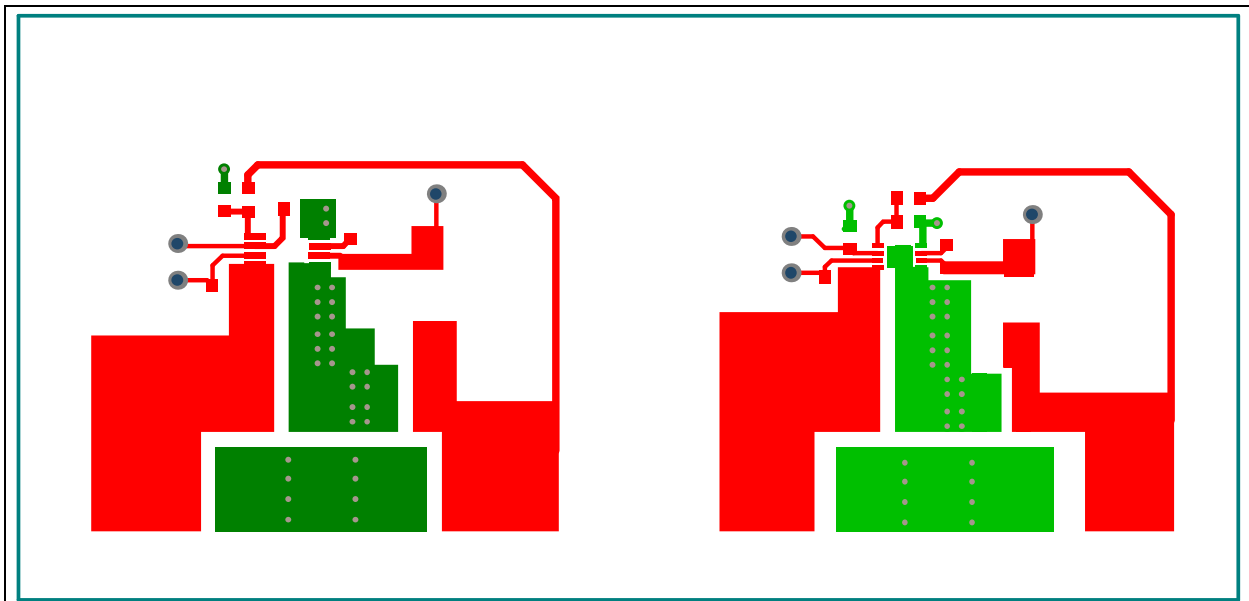

A.5 BOARD – TOP COPPER AND SILK

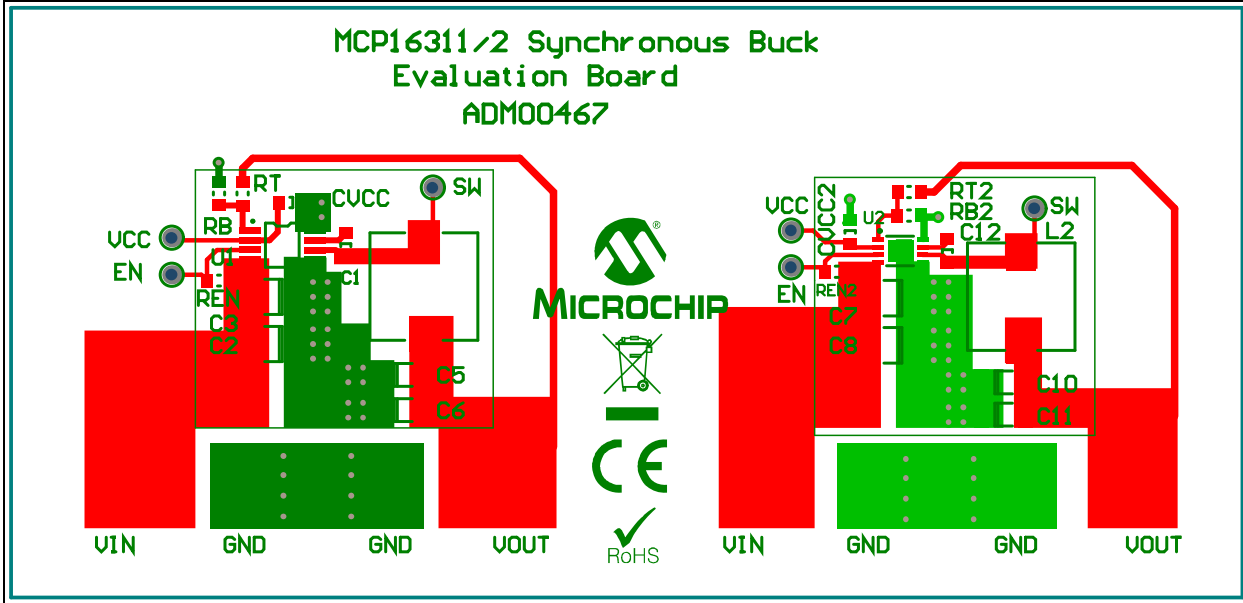

A.6 BOARD – BOTTOM COPPER

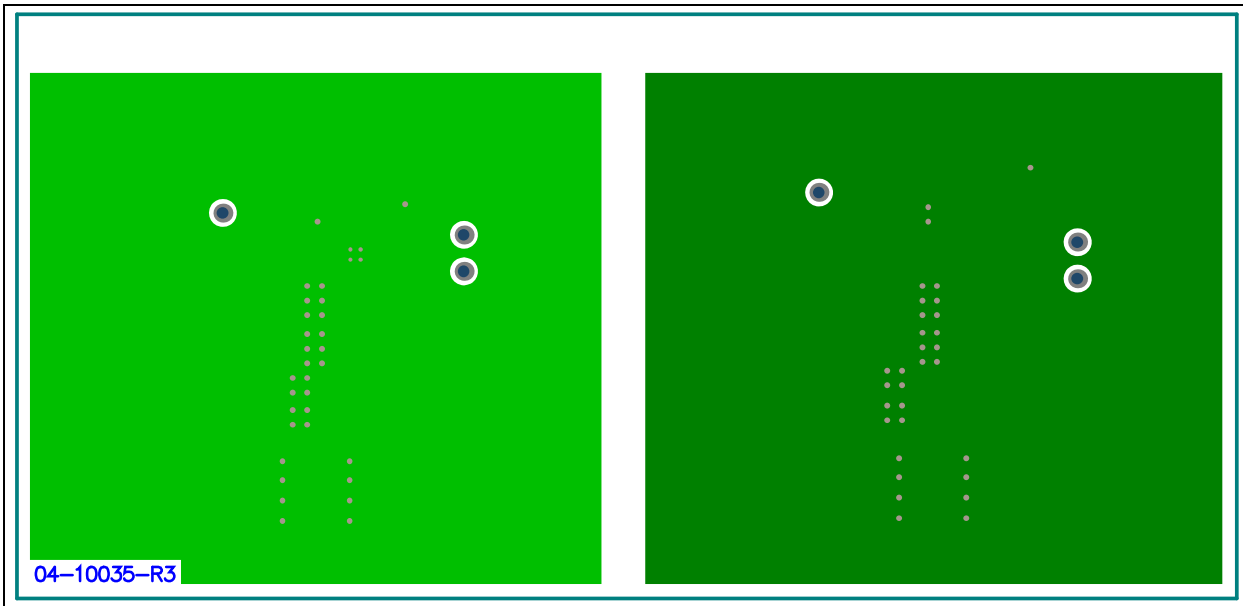



MCP16311/2 SYNCHRONOUS BUCK CONVERTER EVALUATION BOARD USER'S GUIDE

Appendix B. Bill of Materials (BOM)

TABLE B-1: BILL OF MATERIALS (BOM)

Qty	Reference	Description	Manufacturer	Part Number
2	C1, C12	CAP CER 0.1 μ F 50V X7R 10% 0603	TDK Corporation	C1608X7R1H104K
4	C2, C3, C7, C8	CAP CER 10 μ F 50V X7S 1210	TDK Corporation	C3225X7S1H106M
4	C5, C6, C10, C11	CAPACITOR, 1206, X7R, 16V, 10 μ F	TDK Corporation	C3216X7R1C106K
2	CVCC, CVCC2	CAP CER 1 μ F 16V 10% X7R 0603	TDK Corporation	C1608X7R1C105K
8	J1, J2, J3, J4, J5, J6, J7, J8	PC TEST POINT TIN SMD	Harwin Plc.	S1751-46R
1	L1	CHOKE, SMD, 15 μ H	Würth Group	7447779115
1	L2	CHOKE, SMD, 22 μ H	Würth Group	7447779122
1	PCB	Printed Circuit Board – MCP16311/2 Synchronous Buck Converter Evaluation Board	—	104-00467
2	RB, RB2	RES 10k Ohm 1/10W 1% 0603 SMD	Panasonic® – ECG	ERJ-3EKF1002V
2	REN, REN2	RES 1M Ohm 1/10W 5% 0603 SMD	Panasonic – ECG	ERJ-3GEYJ105V
1	RT	RESISTOR, 0603 30K9	Multicomp®	MC 0.063W 0603 1% 30K9
1	RT2	RES 52.3k OHM 1/10W 1% 0603 SMD	Panasonic – ECG	ERJ-3EKF5232V
1	U1	30V SYNCHRONOUS BUCK VOLTAGE REGULATOR	Microchip Technology Inc.	MCP16311-E/MS
1	U2	30V SYNCHRONOUS BUCK VOLTAGE REGULATOR	Microchip Technology Inc.	MCP16312T-E/MNY

Note 1: The components listed in this Bill of Materials are representative of the PCB assembly. The released BOM used in manufacturing uses all RoHS-compliant components.



MICROCHIP

Worldwide Sales and Service

AMERICAS

Corporate Office

2355 West Chandler Blvd.
Chandler, AZ 85224-6199
Tel: 480-792-7200
Fax: 480-792-7277
Technical Support:
<http://www.microchip.com/support>
Web Address:
www.microchip.com

Atlanta

Duluth, GA
Tel: 678-957-9614
Fax: 678-957-1455

Austin, TX

Tel: 512-257-3370

Boston

Westborough, MA
Tel: 774-760-0087
Fax: 774-760-0088

Chicago

Itasca, IL
Tel: 630-285-0071
Fax: 630-285-0075

Cleveland

Independence, OH
Tel: 216-447-0464
Fax: 216-447-0643

Dallas

Addison, TX
Tel: 972-818-7423
Fax: 972-818-2924

Detroit

Novi, MI
Tel: 248-848-4000

Houston, TX

Tel: 281-894-5983

Indianapolis

Noblesville, IN
Tel: 317-773-8323
Fax: 317-773-5453

Los Angeles

Mission Viejo, CA
Tel: 949-462-9523
Fax: 949-462-9608

New York, NY

Tel: 631-435-6000

San Jose, CA

Tel: 408-735-9110

Canada - Toronto

Tel: 905-673-0699
Fax: 905-673-6509

ASIA/PACIFIC

Asia Pacific Office

Suites 3707-14, 37th Floor
Tower 6, The Gateway
Harbour City, Kowloon
Hong Kong
Tel: 852-2401-1200
Fax: 852-2401-3431

Australia - Sydney

Tel: 61-2-9868-6733
Fax: 61-2-9868-6755

China - Beijing

Tel: 86-10-8569-7000
Fax: 86-10-8528-2104

China - Chengdu

Tel: 86-28-8665-5511
Fax: 86-28-8665-7889

China - Chongqing

Tel: 86-23-8980-9588
Fax: 86-23-8980-9500

China - Hangzhou

Tel: 86-571-2819-3187
Fax: 86-571-2819-3189

China - Hong Kong SAR

Tel: 852-2943-5100
Fax: 852-2401-3431

China - Nanjing

Tel: 86-25-8473-2460
Fax: 86-25-8473-2470

China - Qingdao

Tel: 86-532-8502-7355
Fax: 86-532-8502-7205

China - Shanghai

Tel: 86-21-5407-5533
Fax: 86-21-5407-5066

China - Shenyang

Tel: 86-24-2334-2829
Fax: 86-24-2334-2393

China - Shenzhen

Tel: 86-755-8864-2200
Fax: 86-755-8203-1760

China - Wuhan

Tel: 86-27-5980-5300
Fax: 86-27-5980-5118

China - Xian

Tel: 86-29-8833-7252
Fax: 86-29-8833-7256

China - Xiamen

Tel: 86-592-2388138
Fax: 86-592-2388130

China - Zhuhai

Tel: 86-756-3210040
Fax: 86-756-3210049

ASIA/PACIFIC

India - Bangalore

Tel: 91-80-3090-4444
Fax: 91-80-3090-4123

India - New Delhi

Tel: 91-11-4160-8631
Fax: 91-11-4160-8632

India - Pune

Tel: 91-20-3019-1500

Japan - Osaka

Tel: 81-6-6152-7160
Fax: 81-6-6152-9310

Japan - Tokyo

Tel: 81-3-6880-3770
Fax: 81-3-6880-3771

Korea - Daegu

Tel: 82-53-744-4301
Fax: 82-53-744-4302

Korea - Seoul

Tel: 82-2-554-7200
Fax: 82-2-558-5932 or
82-2-558-5934

Malaysia - Kuala Lumpur

Tel: 60-3-6201-9857
Fax: 60-3-6201-9859

Malaysia - Penang

Tel: 60-4-227-8870
Fax: 60-4-227-4068

Philippines - Manila

Tel: 63-2-634-9065
Fax: 63-2-634-9069

Singapore

Tel: 65-6334-8870
Fax: 65-6334-8850

Taiwan - Hsin Chu

Tel: 886-3-5778-366
Fax: 886-3-5770-955

Taiwan - Kaohsiung

Tel: 886-7-213-7830

Taiwan - Taipei

Tel: 886-2-2508-8600
Fax: 886-2-2508-0102

Thailand - Bangkok

Tel: 66-2-694-1351
Fax: 66-2-694-1350

EUROPE

Austria - Wels

Tel: 43-7242-2244-39
Fax: 43-7242-2244-393

Denmark - Copenhagen

Tel: 45-4450-2828
Fax: 45-4485-2829

France - Paris

Tel: 33-1-69-53-63-20
Fax: 33-1-69-30-90-79

Germany - Dusseldorf

Tel: 49-2129-3766400

Germany - Munich

Tel: 49-89-627-144-0
Fax: 49-89-627-144-44

Germany - Pforzheim

Tel: 49-7231-424750

Italy - Milan

Tel: 39-0331-742611
Fax: 39-0331-466781

Italy - Venice

Tel: 39-049-7625286

Netherlands - Drunen

Tel: 31-416-690399
Fax: 31-416-690340

Poland - Warsaw

Tel: 48-22-3325737

Spain - Madrid

Tel: 34-91-708-08-90
Fax: 34-91-708-08-91

Sweden - Stockholm

Tel: 46-8-5090-4654

UK - Wokingham

Tel: 44-118-921-5800
Fax: 44-118-921-5820

10/28/13



Компания «ЭлектроПласт» предлагает заключение долгосрочных отношений при поставках импортных электронных компонентов на взаимовыгодных условиях!

Наши преимущества:

- Оперативные поставки широкого спектра электронных компонентов отечественного и импортного производства напрямую от производителей и с крупнейших мировых складов;
- Поставка более 17-ти миллионов наименований электронных компонентов;
- Поставка сложных, дефицитных, либо снятых с производства позиций;
- Оперативные сроки поставки под заказ (от 5 рабочих дней);
- Экспресс доставка в любую точку России;
- Техническая поддержка проекта, помощь в подборе аналогов, поставка прототипов;
- Система менеджмента качества сертифицирована по Международному стандарту ISO 9001;
- Лицензия ФСБ на осуществление работ с использованием сведений, составляющих государственную тайну;
- Поставка специализированных компонентов (Xilinx, Altera, Analog Devices, Intersil, Interpoint, Microsemi, Aeroflex, Peregrine, Syfer, Eurofarad, Texas Instrument, Miteq, Cobham, E2V, MA-COM, Hittite, Mini-Circuits, General Dynamics и др.);

Помимо этого, одним из направлений компании «ЭлектроПласт» является направление «Источники питания». Мы предлагаем Вам помощь Конструкторского отдела:

- Подбор оптимального решения, техническое обоснование при выборе компонента;
- Подбор аналогов;
- Консультации по применению компонента;
- Поставка образцов и прототипов;
- Техническая поддержка проекта;
- Защита от снятия компонента с производства.



Как с нами связаться

Телефон: 8 (812) 309 58 32 (многоканальный)

Факс: 8 (812) 320-02-42

Электронная почта: org@eplast1.ru

Адрес: 198099, г. Санкт-Петербург, ул. Калинина, дом 2, корпус 4, литера А.