

LOC	DIST	REVISIONS					
GP	00	P	LTN	DESCRIPTION	DATE	DWN	APVD
		A		RELEASED PER ECO-12-013192	19OCT2012	BMM	MRS

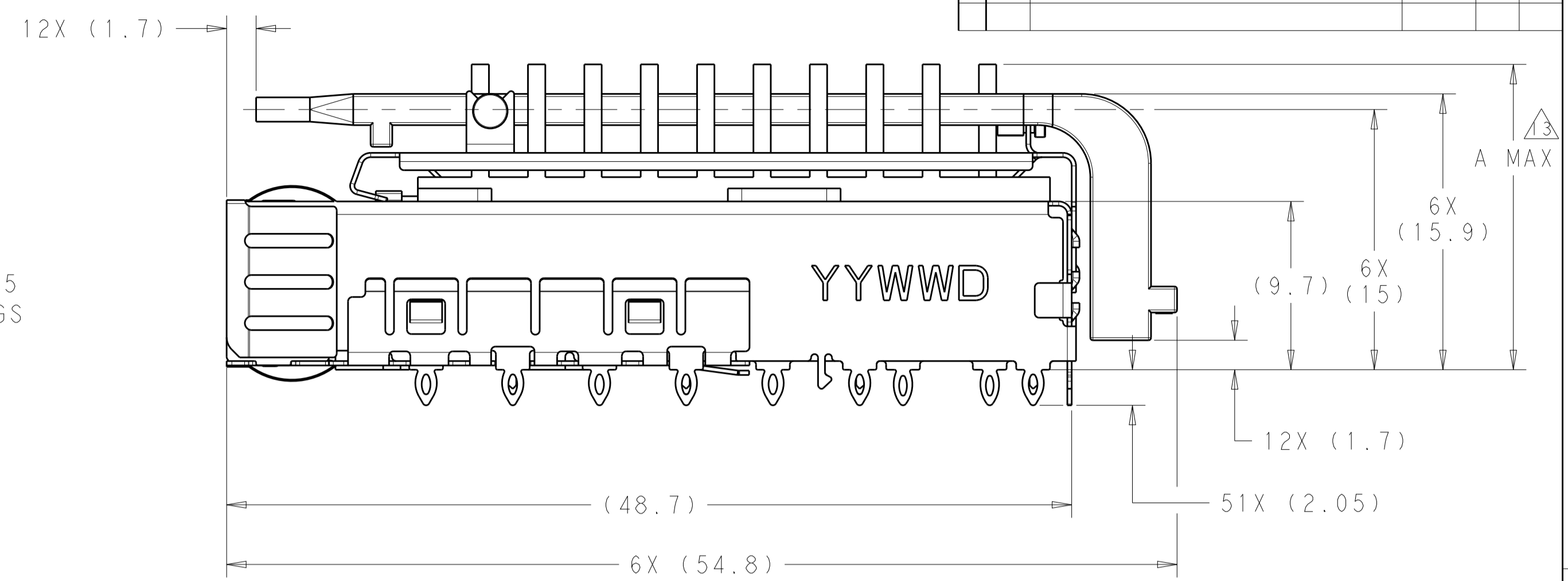
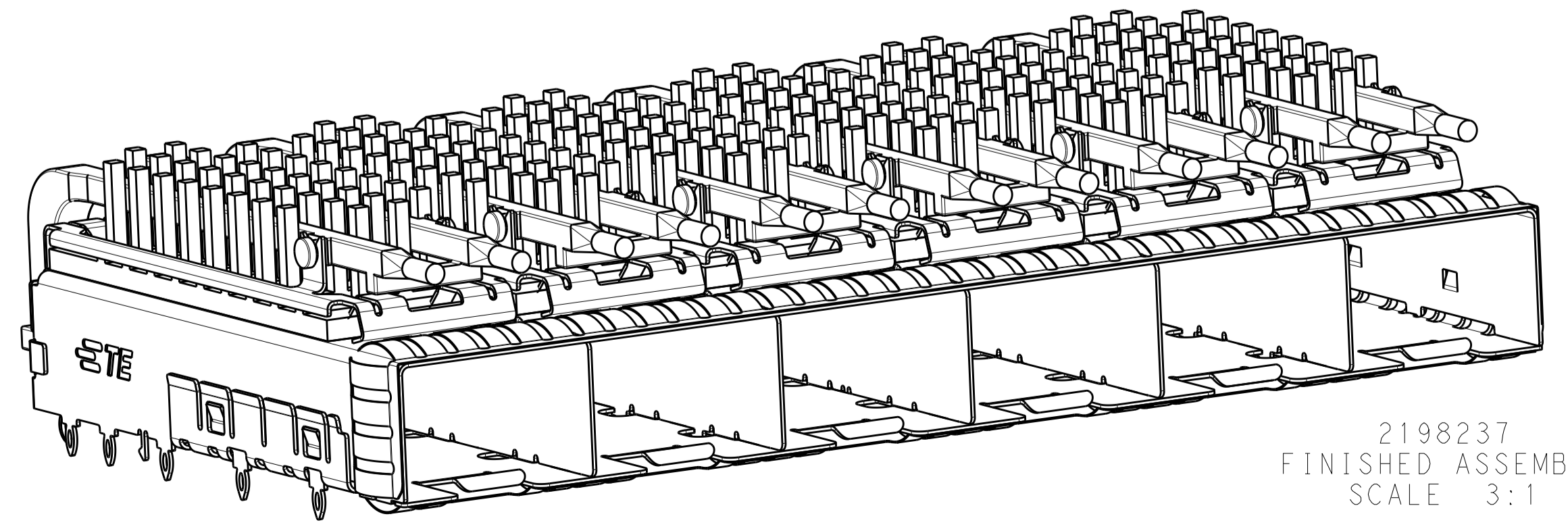
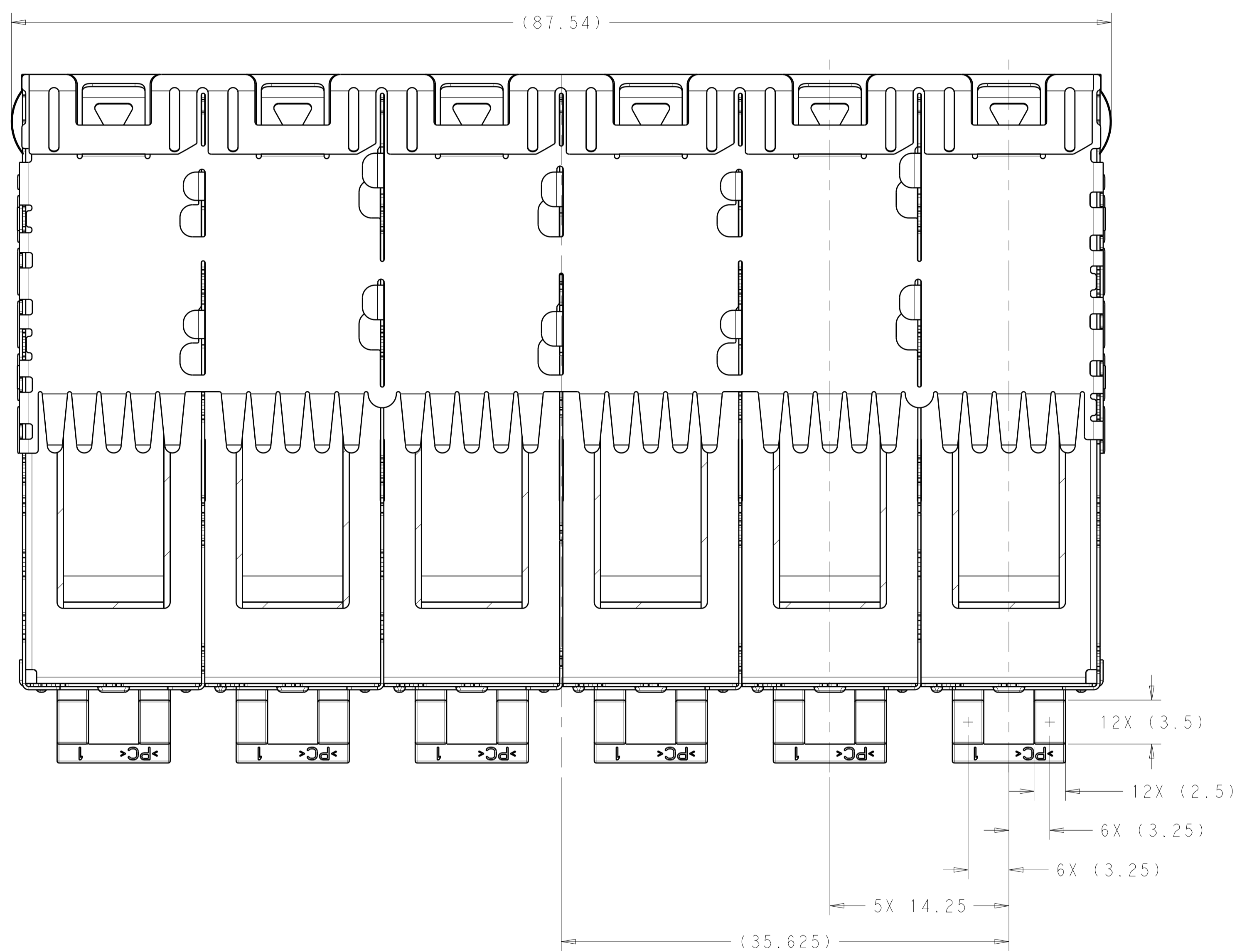
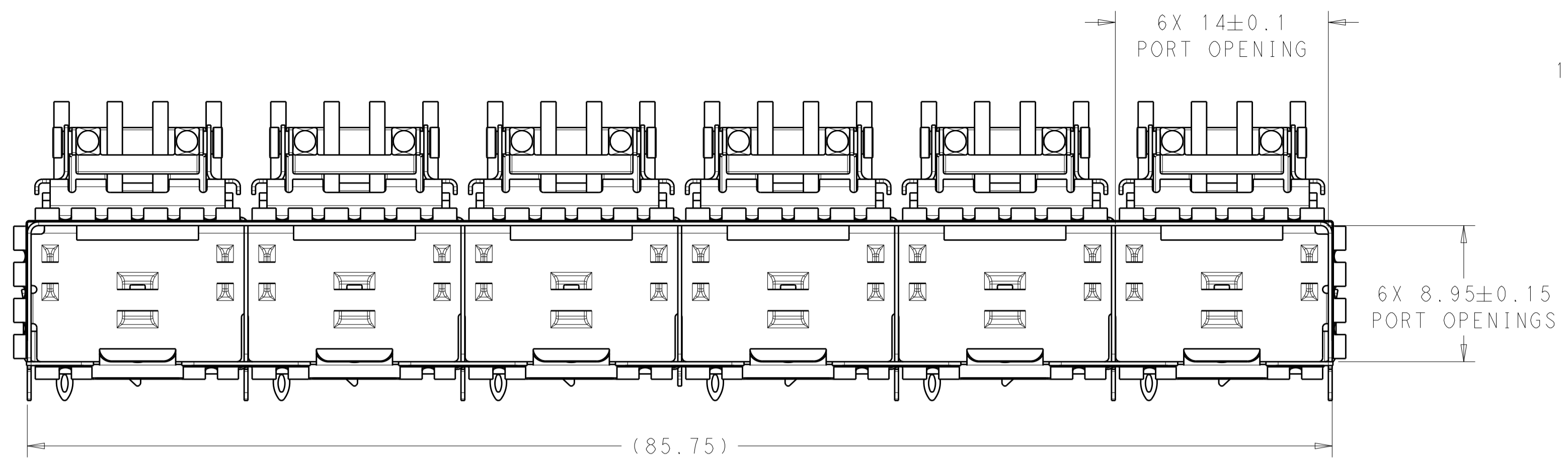

- △ MATERIAL:
CAGE ASSEMBLY: 0.25mm THICK NICKEL SILVER ALLOY.
HEATSINK/LIGHTPIPE CLIP: STAINLESS STEEL
LIGHT PIPE: POLYCARBONATE, CLEAR
HEATSINK: ALUMINUM
- △ FINISH:
SPRINGS: MINIMUM OF 0.8um TIN PLATE OVER A MINIMUM OF 0.8um NICKEL UNDERPLATE.
NON-PLATED EDGES PERMISSIBLE.
HEATSINK/LIGHTPIPE CLIP: PASSIVATE
HEATSINK: ELECTROLESS NICKEL
- 3. MATES WITH SFP MSA COMPLIANT TRANSCEIVERS.
- △ PADS AND VIAS CHASSIS GROUND.
- 5. INTERPRETATION OF DATUM REFERENCE FRAME IN ACCORDANCE WITH SECT 4.4.1.1 OF ASME Y14.5M-1994.
- △ MINIMUM PCB BOARD THICKNESS:
SINGLE SIDED = 1.50mm
DOUBLE SIDED = 2.25mm
- △ HOLE PATTERN REPEATS FOR EACH PORT. SPACING BETWEEN PORTS IS 14.25mm.
- △ DATUM AND BASIC DIMENSION ESTABLISHED BY CUSTOMER.
- △ REFERENCE APPLICATION SPEC. 114-13120, HOLE A, FOR RECOMMENDED DRILL HOLE DIAMETER AND PLATING THICKNESS.
- △ REFERENCE APPLICATION SPEC. 114-13120, HOLE B, FOR RECOMMENDED DRILL HOLE DIAMETER AND PLATING THICKNESS.
- 11. CERTAIN MATING TRANSCEIVERS MAY REQUIRE ADDITIONAL PCB THICKNESS THAT WOULD BE DETERMINED BY THE CUSTOMER.
- 12. PRODUCT COMPLIES WITH SPECIFICATION SFF-8433 IMPROVED PLUGGABLE FORM FACTOR FOR SFP+ GANGED CAGES.
- △ DIMENSION APPLIES PRIOR TO INSERTION OF SFP MODULE.
- △ HEATSINK, HEATSINK CLIP, AND LIGHTPIPE SHIPPED UNASSEMBLED TO CAGE ASSEMBLY. CAGE ASSEMBLY TO BE PRESSED INTO PCB PRIOR TO ATTACHING HEATSINK, HEATSINK CLIP, AND LIGHTPIPE TO THE CAGE ASSEMBLY.
- △ PACKAGED AS A COMPLETE ASSEMBLY.

△	22.5	NETWORKING, TALL	2198237-4
△	18.1	NETWORKING, SHORT	2198237-3
△	15.5	SAN	2198237-2
△	13.2	PCI	2198237-1
	A MAX	APPLICATION	PART NUMBER

THIS DRAWING IS A CONTROLLED DOCUMENT.		DWN	B. MATTHEWS	15NOV2011
DIMENSIONS:		CHK	M. SCHMITT	15NOV2011
mm	0 PLC ±0.1	APVD	M. SCHMITT	15NOV2011
	1 PLC ±0.1	PRODUCT SPEC		
	2 PLC ±0.1	108-2364		
	3 PLC ±0.1	APPLICATION SPEC		
	4 PLC ±0.1	114-13120		
	ANGLES ±0.1	WEIGHT		
	FINISH ±1*	SIZE CAGE CODE DRAWING NO		
MATERIAL	△	RESTRICTED TO		
	△	A100779C=2198237		
Customer Drawing		SCALE 4:1 SHEET 1 OF 4 REV A		

LOC	DIST	REV	DATE	BY	APPV
GP	00				

REVISIONS		
NO.	DESCRIPTION	DATE
1	SEE SHEET 1	

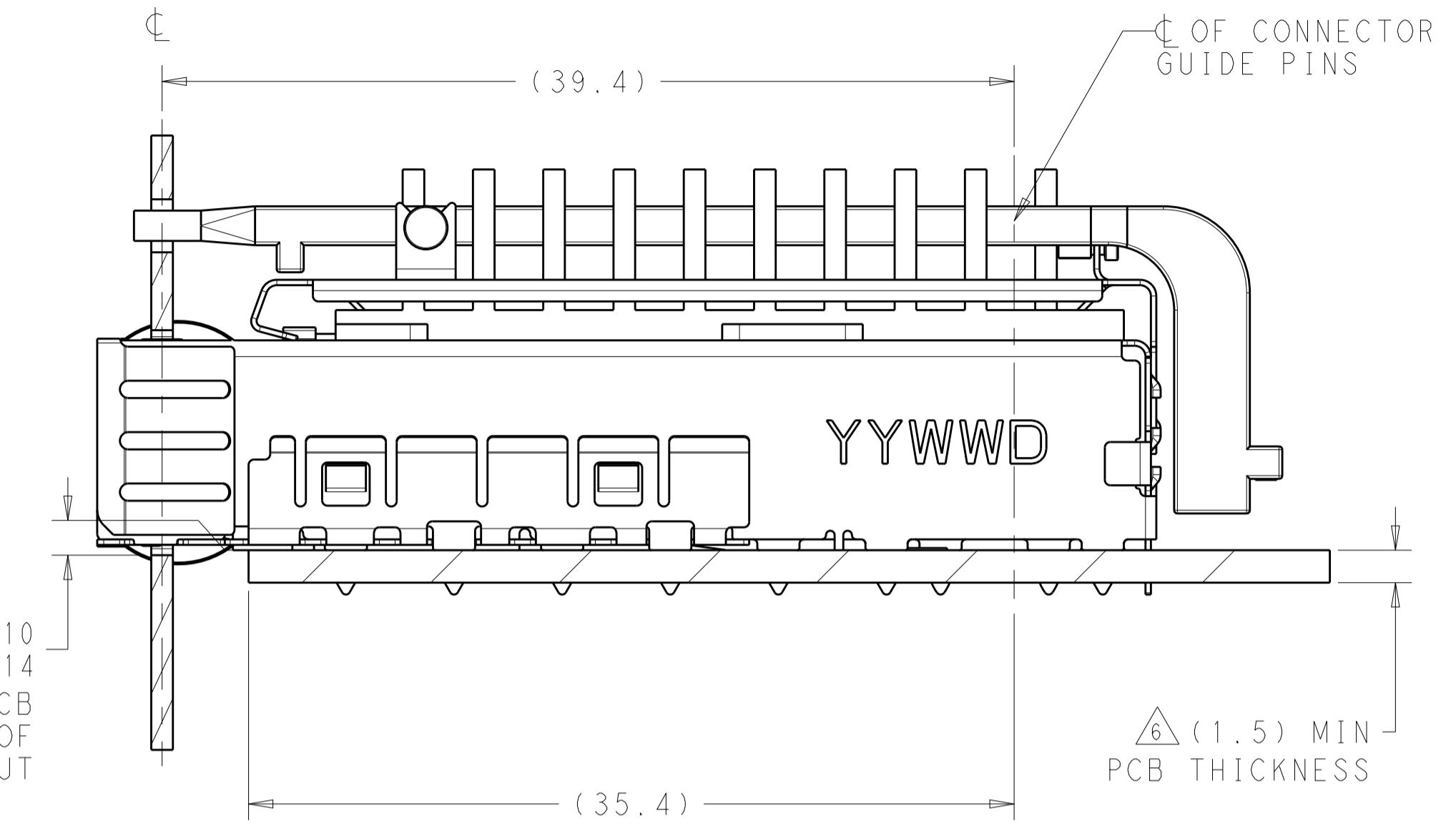
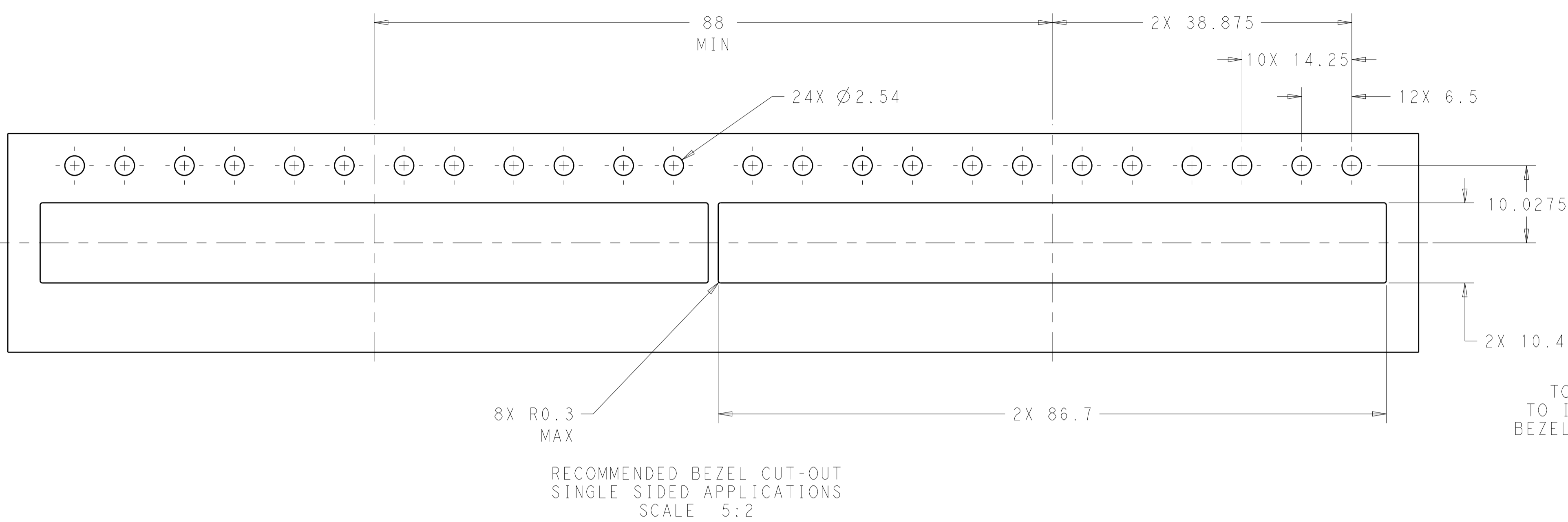

2198237
MOUNTED ON PC BOARD
SHOWN THRU RECOMMENDED BEZEL

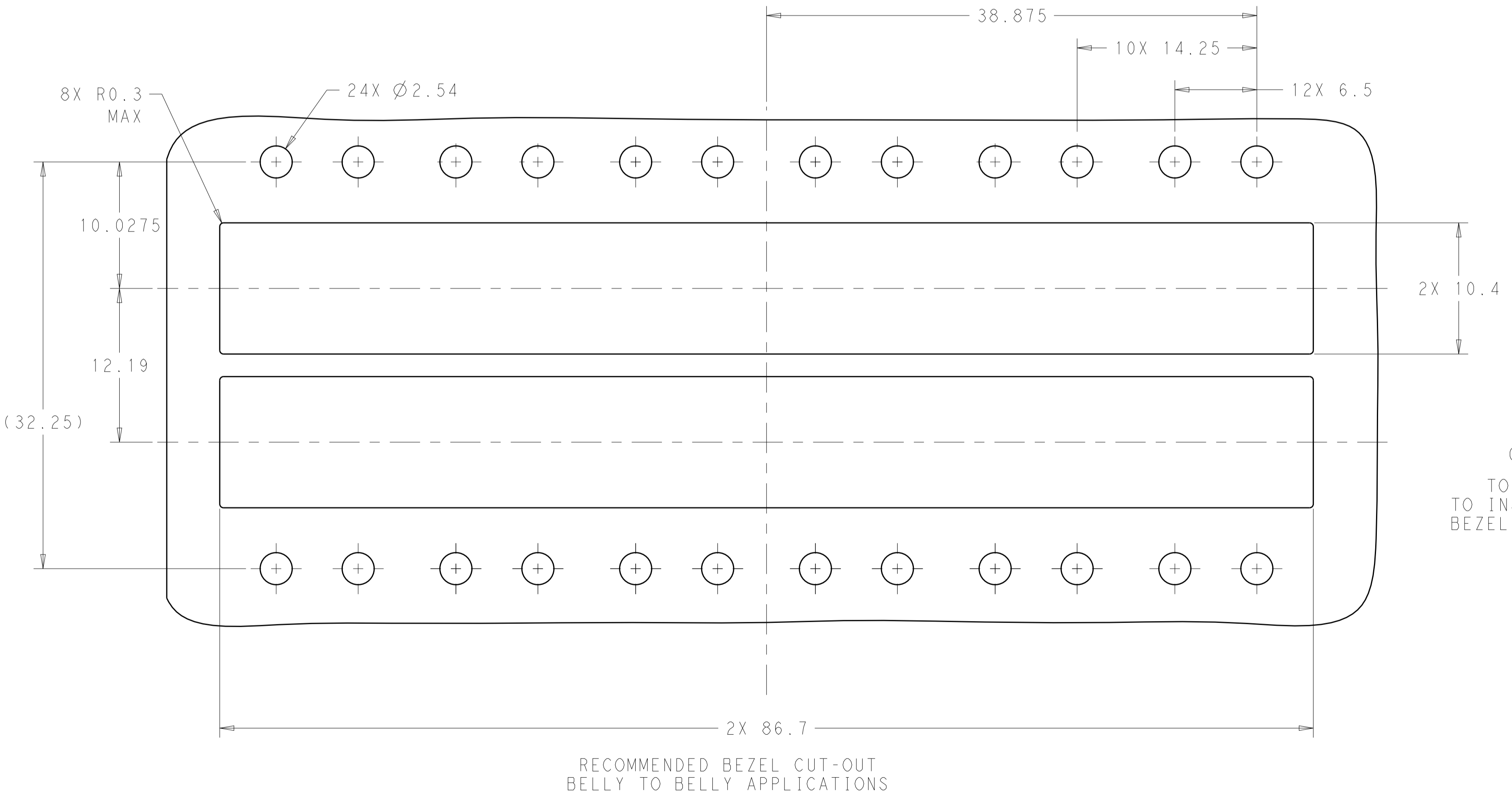

0.23+0.10
-0.14
TOP OF PCB
TO INSIDE OF
BEZEL CUT-OUT

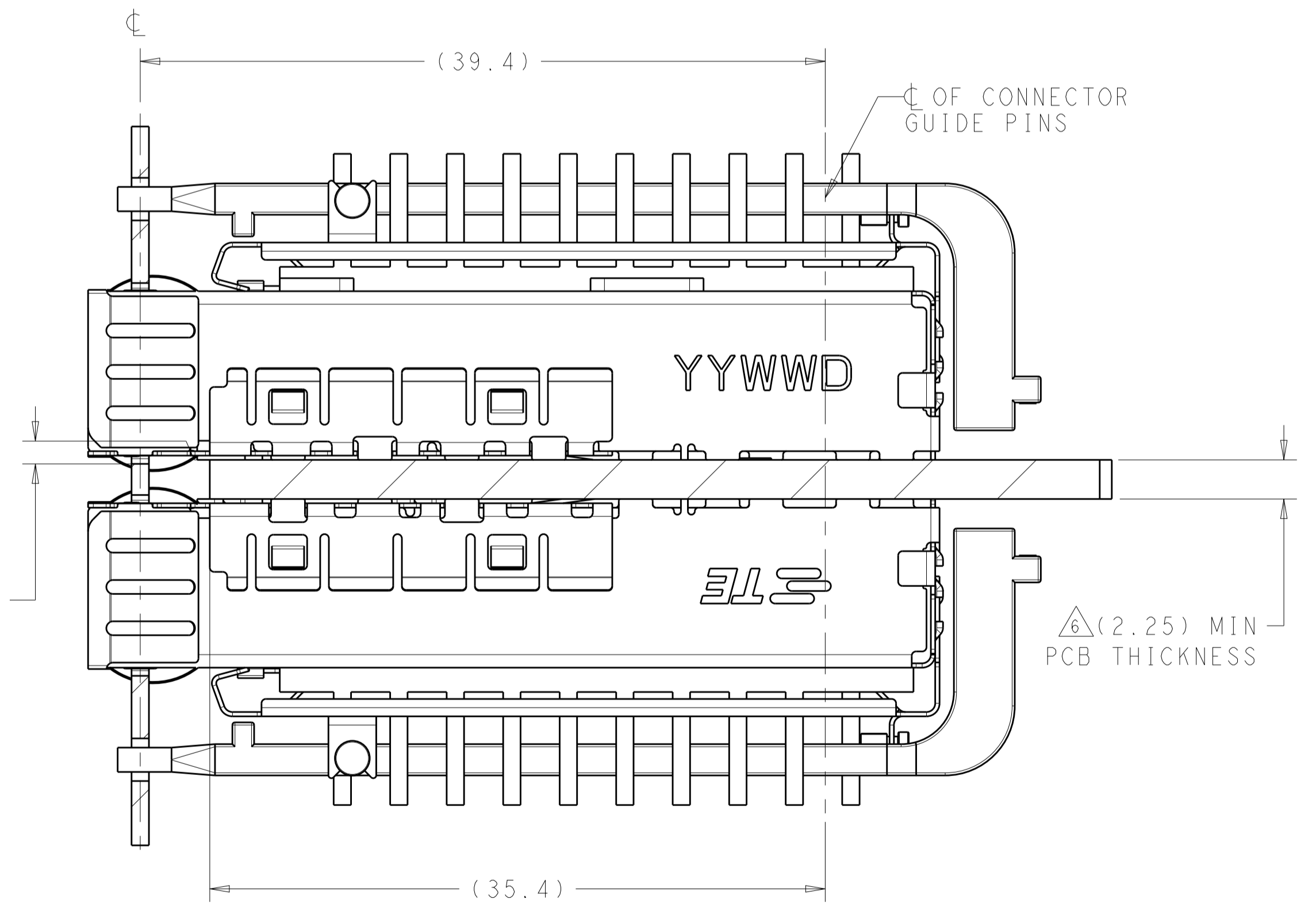

2198237
MOUNTED BELLY TO BELLY ON PC BOARD
SHOWN THRU RECOMMENDED BEZEL

THIS DRAWING IS A CONTROLLED DOCUMENT.		DWN B. MATTHEWS 15NOV2011	TE Connectivity												
DIMENSIONS: mm		CHK M. SCHMITT 15NOV2011													
TOLERANCES UNLESS OTHERWISE SPECIFIED:		APVD M. SCHMITT 15NOV2011	NAME SFP+ ENHANCED 1X6 CAGE ASSEMBLY, PRESS FIT, EXTERNAL EMI SPRINGS WITH HEATSINK AND LIGHTPIPE												
<table border="1"> <tr> <td>0 PLC</td> <td>±0.1</td> </tr> <tr> <td>1 PLC</td> <td>±0.1</td> </tr> <tr> <td>2 PLC</td> <td>±0.1</td> </tr> <tr> <td>3 PLC</td> <td>±0.1</td> </tr> <tr> <td>4 PLC</td> <td>±0.1</td> </tr> <tr> <td>ANGLES</td> <td>±1°</td> </tr> </table>		0 PLC	±0.1	1 PLC	±0.1	2 PLC	±0.1	3 PLC	±0.1	4 PLC	±0.1	ANGLES	±1°	PRODUCT SPEC 108-2364	SIZE 114-13120
0 PLC	±0.1														
1 PLC	±0.1														
2 PLC	±0.1														
3 PLC	±0.1														
4 PLC	±0.1														
ANGLES	±1°														
MATERIAL		WEIGHT	RESTRICTED TO												
FINISH		Customer Drawing	SCALE 4:1 SHEET 2 OF 4 REV A												

LOC	DIST	REV	DATE	BY	APPV
GP	00				

REVISIONS			
NO.	DESCRIPTION	DATE	BY
1	SEE SHEET 1		

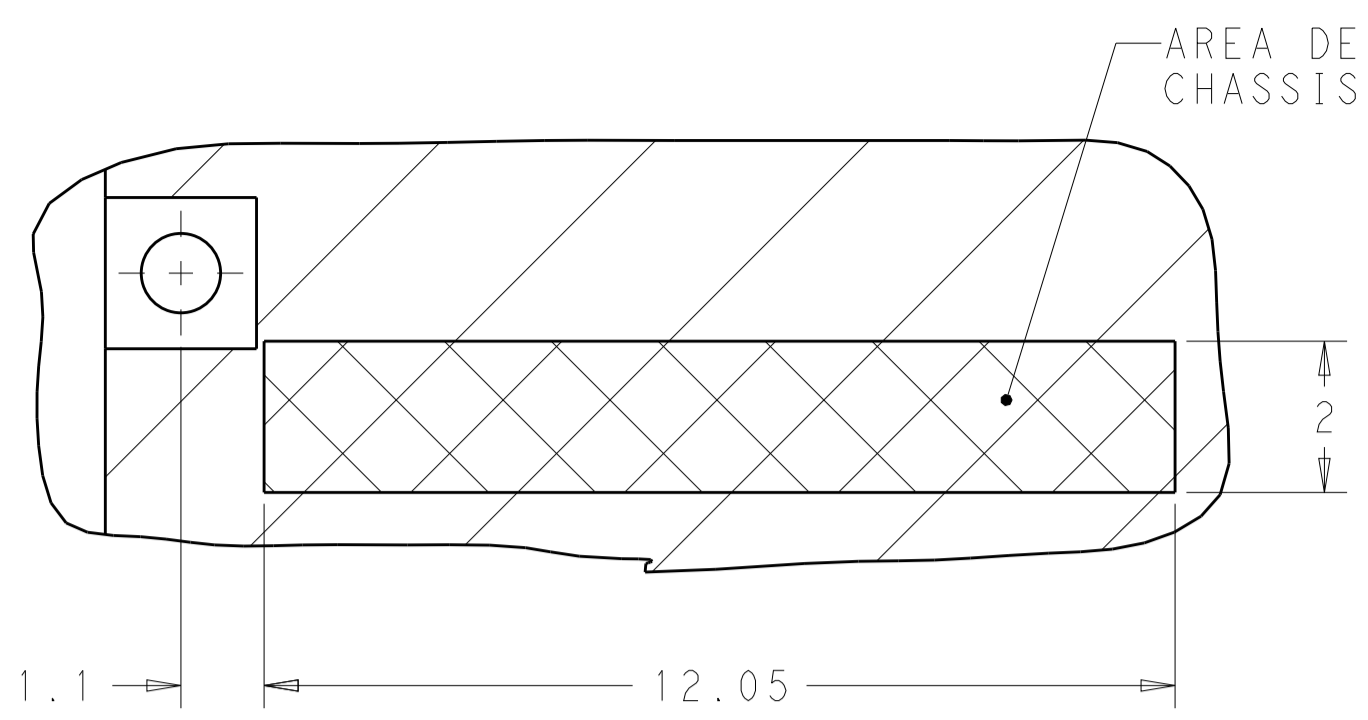

DETAIL A
6X INDIVIDUALLY
SCALE 10:1

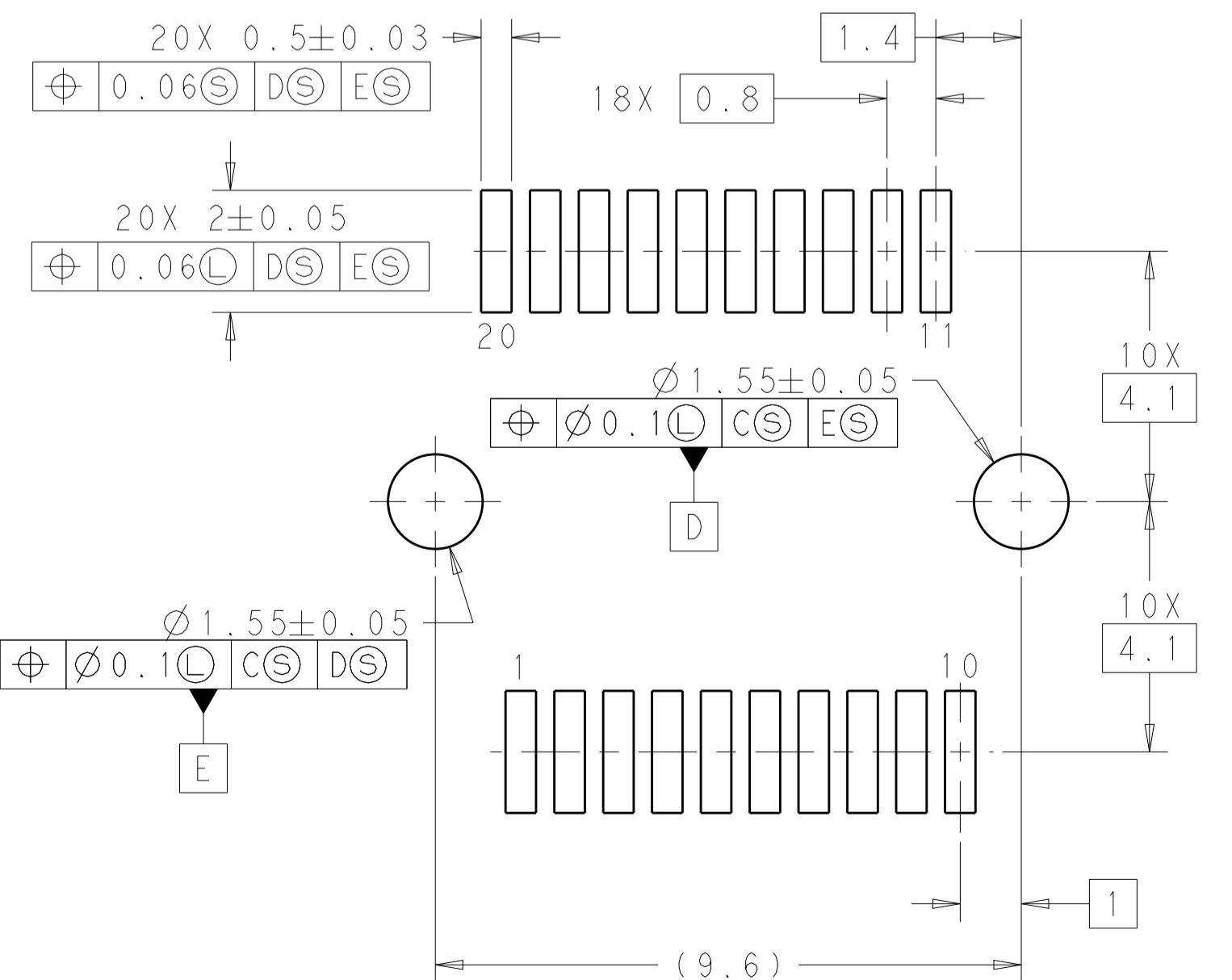
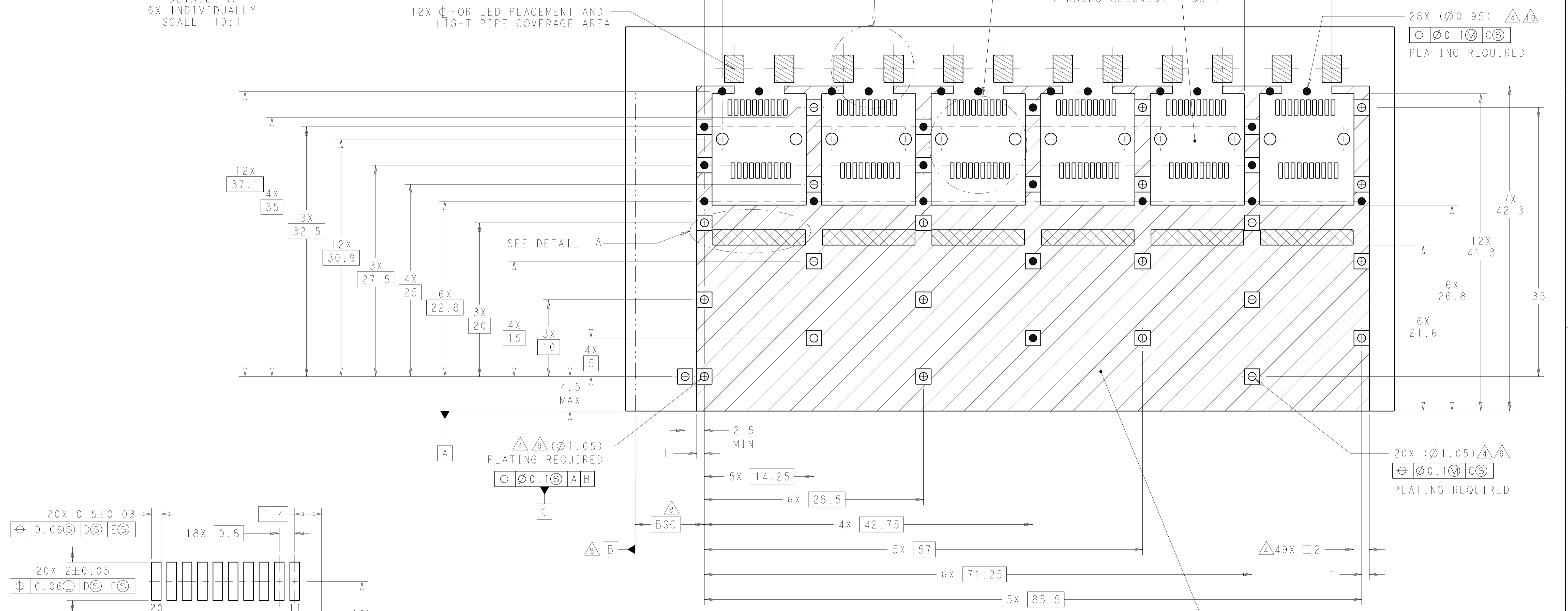

DETAIL X
RECOMMENDED PT CONNECTOR LAYOUT
6X INDIVIDUALLY
SCALE 10:1

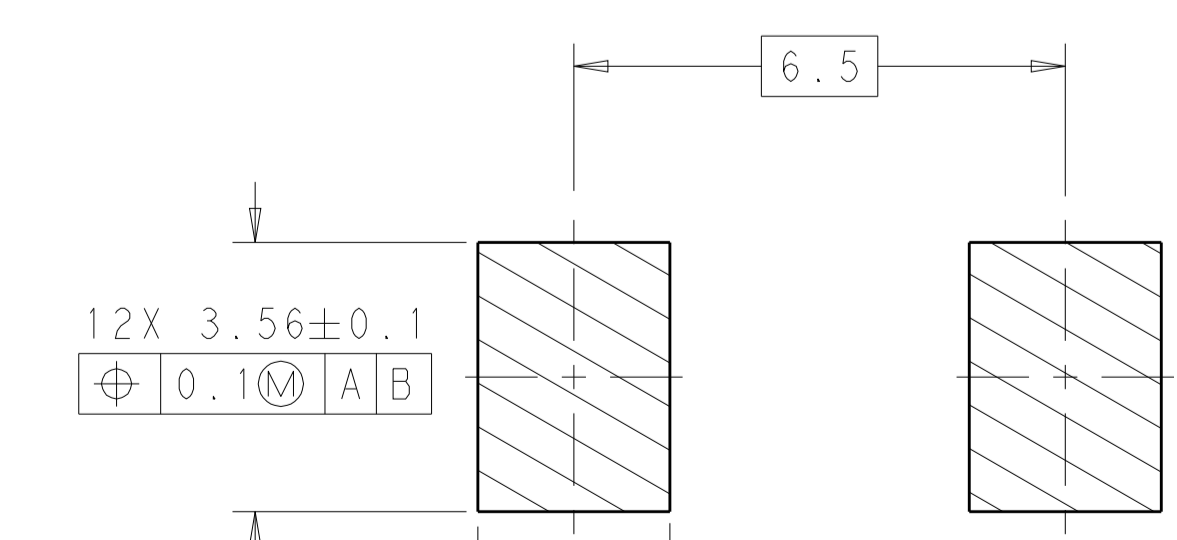

DETAIL W
SCALE 10:1

THIS DRAWING IS A CONTROLLED DOCUMENT.		DWN: B. MATTHEWS 15NOV2011	TE Connectivity
DIMENSIONS: mm		CHK: M. SCHMITT 15NOV2011	
TOLERANCES UNLESS OTHERWISE SPECIFIED:		APVD: M. SCHMITT 15NOV2011	NAME: SFP+ ENHANCED 1X6 CAGE ASSEMBLY, PRESS FIT, EXTERNAL EMI SPRINGS WITH HEATSINK AND LIGHTPIPE PRODUCT SPEC: 108-2364 APPLICATION SPEC: SIZE: 114-13120 WEIGHT: CUSTOMER DRAWING
0 PLC ±0.1		RESTRICTED TO	
1 PLC ±0.1		SCALE: 4:1	
2 PLC ±0.1		SHEET 3 OF 4	
3 PLC ±0.1		REV: A	
4 PLC ±0.1			
ANGLES ±0.1			
FINISH: #1*			



Компания «ЭлектроПласт» предлагает заключение долгосрочных отношений при поставках импортных электронных компонентов на взаимовыгодных условиях!

Наши преимущества:

- Оперативные поставки широкого спектра электронных компонентов отечественного и импортного производства напрямую от производителей и с крупнейших мировых складов;
- Поставка более 17-ти миллионов наименований электронных компонентов;
- Поставка сложных, дефицитных, либо снятых с производства позиций;
- Оперативные сроки поставки под заказ (от 5 рабочих дней);
- Экспресс доставка в любую точку России;
- Техническая поддержка проекта, помощь в подборе аналогов, поставка прототипов;
- Система менеджмента качества сертифицирована по Международному стандарту ISO 9001;
- Лицензия ФСБ на осуществление работ с использованием сведений, составляющих государственную тайну;
- Поставка специализированных компонентов (Xilinx, Altera, Analog Devices, Intersil, Interpoint, Microsemi, Aeroflex, Peregrine, Syfer, Eurofarad, Texas Instrument, Miteq, Cobham, E2V, MA-COM, Hittite, Mini-Circuits, General Dynamics и др.);

Помимо этого, одним из направлений компании «ЭлектроПласт» является направление «Источники питания». Мы предлагаем Вам помощь Конструкторского отдела:

- Подбор оптимального решения, техническое обоснование при выборе компонента;
- Подбор аналогов;
- Консультации по применению компонента;
- Поставка образцов и прототипов;
- Техническая поддержка проекта;
- Защита от снятия компонента с производства.



Как с нами связаться

Телефон: 8 (812) 309 58 32 (многоканальный)

Факс: 8 (812) 320-02-42

Электронная почта: org@eplast1.ru

Адрес: 198099, г. Санкт-Петербург, ул. Калинина, дом 2, корпус 4, литера А.