



## Eight Output Differential Buffer for PCI-Express

**Recommended Application:**

DB800 Intel Yellow Cover part with PCI-Express support.

**Output Features:**

- 8 - 0.7V current-mode differential output pairs
- Supports zero delay buffer mode and fanout mode
- Bandwidth programming available

**Key Specifications:**

- Outputs cycle-cycle jitter < 50ps
- Outputs skew: 50ps
- +/- 300ppm frequency accuracy on output clocks

**Features/Benefits:**

- Supports tight ppm accuracy clocks for Serial-ATA
- Spread spectrum modulation tolerant, 0 to -0.5% down spread and +/- 0.25% center spread
- Supports undriven differential output pair in PD# and SRC\_STOP# for power management.

**Pin Configuration**

SRC_DIV#	1	48	VDDA
VDD	2	47	GNDA
GND	3	46	IREF
SRC_IN	4	45	LOCK
SRC_IN#	5	44	OE_7
OE_0	6	43	OE_4
OE_3	7	42	DIF_7
DIF_0	8	41	DIF_7#
DIF_0#	9	40	GND
GND	10	39	VDD
VDD	11	38	DIF_6
DIF_1	12	37	DIF_6#
DIF_1#	13	36	OE_6
OE_1	14	35	OE_5
OE_2	15	34	DIF_5
DIF_2	16	33	DIF_5#
DIF_2#	17	32	GND
GND	18	31	VDD
VDD	19	30	DIF_4
DIF_3	20	29	DIF_4#
DIF_3#	21	28	HIGH_BW#
BYPASS#/PLL	22	27	SRC_STOP#
SCLK	23	26	PD#
SDATA	24	25	GND

ICS9DB108

**48-pin SSOP & TSSOP**

Not recommended for new designs



### Pin Description

PIN #	PIN NAME	PIN TYPE	DESCRIPTION
1	SRC_DIV#	IN	Active low Input for determining SRC output frequency SRC or SRC/2. 0 = SRC/2, 1= SRC
2	VDD	PWR	Power supply, nominal 3.3V
3	GND	PWR	Ground pin.
4	SRC_IN	IN	0.7 V Differential SRC TRUE input
5	SRC_IN#	IN	0.7 V Differential SRC COMPLEMENTARY input
6	OE_0	IN	Active high input for enabling outputs. 0 = tri-state outputs, 1= enable outputs
7	OE_3	IN	Active high input for enabling outputs. 0 = tri-state outputs, 1= enable outputs
8	DIF_0	OUT	0.7V differential true clock outputs
9	DIF_0#	OUT	0.7V differential complement clock outputs
10	GND	PWR	Ground pin.
11	VDD	PWR	Power supply, nominal 3.3V
12	DIF_1	OUT	0.7V differential true clock outputs
13	DIF_1#	OUT	0.7V differential complement clock outputs
14	OE_1	IN	Active high input for enabling outputs. 0 = tri-state outputs, 1= enable outputs
15	OE_2	IN	Active high input for enabling outputs. 0 = tri-state outputs, 1= enable outputs
16	DIF_2	OUT	0.7V differential true clock outputs
17	DIF_2#	OUT	0.7V differential complement clock outputs
18	GND	PWR	Ground pin.
19	VDD	PWR	Power supply, nominal 3.3V
20	DIF_3	OUT	0.7V differential true clock outputs
21	DIF_3#	OUT	0.7V differential complement clock outputs
22	BYPASS#/PLL	IN	Input to select Bypass(fan-out) or PLL (ZDB) mode 0 = Bypass mode, 1= PLL mode
23	SCLK	IN	Clock pin of SMBus circuitry, 5V tolerant.
24	SDATA	I/O	Data pin for SMBus circuitry, 5V tolerant.



**Pin Description (Continued)**

PIN #	PIN NAME	PIN TYPE	DESCRIPTION
25	GND	PWR	Ground pin.
26	PD#	IN	Asynchronous active low input pin used to power down the device. The internal clocks are disabled and the VCO and the crystal are stopped.
27	SRC_STOP#	IN	Active low input to stop diff outputs.
28	HIGH_BW#	PWR	3.3V input for selecting PLL Band Width 0 = High, 1= Low
29	DIF_4#	OUT	0.7V differential complement clock outputs
30	DIF_4	OUT	0.7V differential true clock outputs
31	VDD	PWR	Power supply, nominal 3.3V
32	GND	PWR	Ground pin.
33	DIF_5#	OUT	0.7V differential complement clock outputs
34	DIF_5	OUT	0.7V differential true clock outputs
35	OE_5	IN	Active high input for enabling outputs. 0 = tri-state outputs, 1= enable outputs
36	OE_6	IN	Active high input for enabling outputs. 0 = tri-state outputs, 1= enable outputs
37	DIF_6#	OUT	0.7V differential complement clock outputs
38	DIF_6	OUT	0.7V differential true clock outputs
39	VDD	PWR	Power supply, nominal 3.3V
40	GND	PWR	Ground pin.
41	DIF_7#	OUT	0.7V differential complement clock outputs
42	DIF_7	OUT	0.7V differential true clock outputs
43	OE_4	IN	Active high input for enabling outputs. 0 = tri-state outputs, 1= enable outputs
44	OE_7	IN	Active high input for enabling outputs. 0 = tri-state outputs, 1= enable outputs
45	LOCK	OUT	3.3V output indicating PLL Lock Status. This pin goes high when lock is achieved.
46	IREF	IN	This pin establishes the reference current for the differential current-mode output pairs. This pin requires a fixed precision resistor tied to ground in order to establish the appropriate current. 475 ohms is the standard value.
47	GNDA	PWR	Ground pin for the PLL core.
48	VDDA	PWR	3.3V power for the PLL core.



### General Description

ICS9DB108 follows the Intel DB400 Differential Buffer Specification. This buffer provides four SRC clocks for PCI-Express, next generation I/O devices. ICS9DB108 is driven by a differential input pair from a CK409/CK410 main clock generator, such as the ICS952601 or ICS954101. ICS9DB108 can run at speeds up to 200MHz. It provides outputs meeting tight cycle-to-cycle jitter (50ps) and output-to-output skew (50ps) requirements.

### Block Diagram

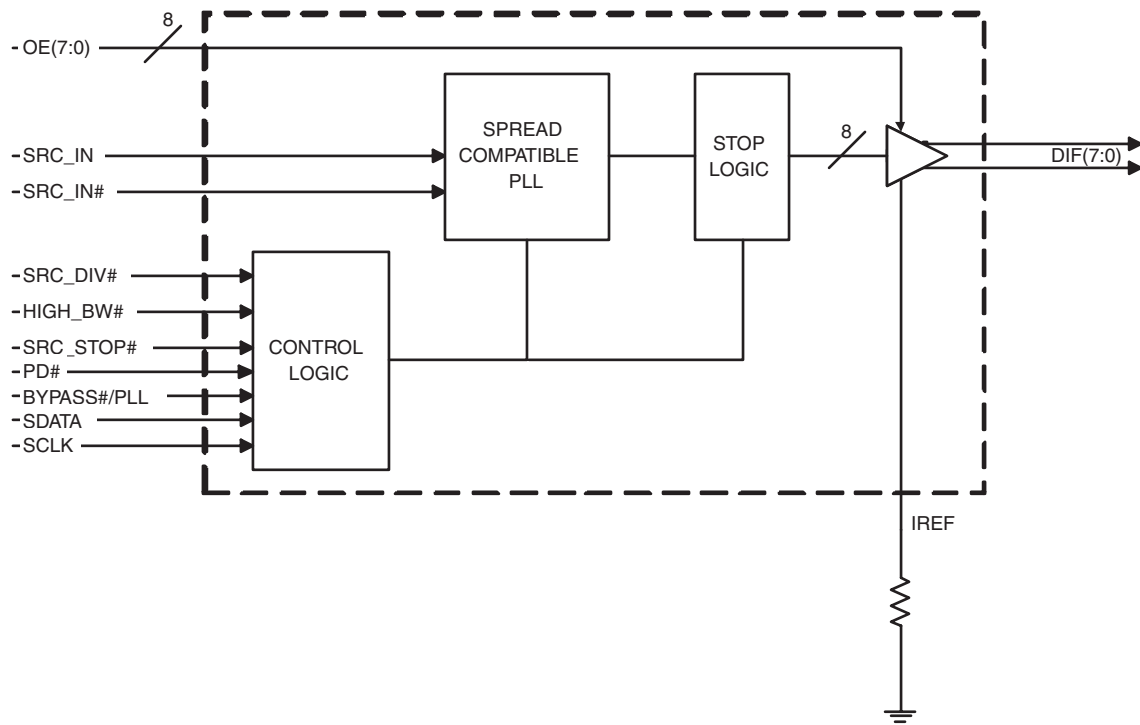

**Absolute Max**

Symbol	Parameter	Min	Max	Units
VDD_A	3.3V Core Supply Voltage		4.6	V
VDD_In	3.3V Logic Supply Voltage		4.6	V
V <sub>IL</sub>	Input Low Voltage	GND-0.5		V
V <sub>IH</sub>	Input High Voltage		V <sub>DD</sub> +0.5V	V
T <sub>s</sub>	Storage Temperature	-65	150	°C
T <sub>ambient</sub>	Ambient Operating Temp	0	70	°C
T <sub>case</sub>	Case Temperature		115	°C
ESD prot	Input ESD protection human body model	2000		V

**Electrical Characteristics - Input/Supply/Common Output Parameters**

T<sub>A</sub> = 0 - 70°C; Supply Voltage V<sub>DD</sub> = 3.3 V +/-5%

PARAMETER	SYMBOL	CONDITIONS	MIN	TYP	MAX	UNITS	NOTES
Input High Voltage	V <sub>IH</sub>	3.3 V +/-5%	2		V <sub>DD</sub> + 0.3	V	
Input Low Voltage	V <sub>IL</sub>	3.3 V +/-5%	GND - 0.3		0.8	V	
Input High Current	I <sub>IH</sub>	V <sub>IN</sub> = V <sub>DD</sub>	-5		5	uA	
Input Low Current	I <sub>IL1</sub>	V <sub>IN</sub> = 0 V; Inputs with no pull-up resistors	-5			uA	
	I <sub>IL2</sub>	V <sub>IN</sub> = 0 V; Inputs with pull-up resistors	-200			uA	
Operating Supply Current	I <sub>DD3.3OP</sub>	Full Active, C <sub>L</sub> = Full load;			250	mA	
Powerdown Current	I <sub>DD3.3PD</sub>	all diff pairs driven			60	mA	
		all differential pairs tri-stated			12	mA	
Input Frequency <sup>3</sup>	F <sub>i</sub>	V <sub>DD</sub> = 3.3 V	80	100/133 166/200	220	MHz	3
Pin Inductance <sup>1</sup>	L <sub>pin</sub>				7	nH	1
Input Capacitance <sup>1</sup>	C <sub>IN</sub>	Logic Inputs	1.5		5	pF	1
	C <sub>OUT</sub>	Output pin capacitance			6	pF	1
PLL Bandwidth	BW	PLL Bandwidth when PLL_BW=0		4		MHz	1
		PLL Bandwidth when PLL_BW=1		2		MHz	1
Clk Stabilization <sup>1,2</sup>	T <sub>STAB</sub>	From V <sub>DD</sub> Power-Up and after input clock stabilization or de-assertion of PD# to 1st clock			1	ms	1,2
Modulation Frequency		Triangular Modulation	30		33	kHz	1
Tdrive_SRC_STOP#		DIF output enable after SRC_Stop# de-assertion			10	ns	1,3
Tdrive_PD#		DIF output enable after PD# de-assertion			300	us	1,3
Tfall		Fall time of PD# and SRC_STOP#			5	ns	1
Trise		Rise time of PD# and SRC_STOP#			5	ns	2

<sup>1</sup>Guaranteed by design and characterization, not 100% tested in production.

<sup>2</sup>See timing diagrams for timing requirements.

<sup>3</sup>Time from deassertion until outputs are >200 mV

**Electrical Characteristics - DIF 0.7V Current Mode Differential Pair**

$T_A = 0 - 70^\circ\text{C}$ ;  $V_{DD} = 3.3\text{ V} \pm 5\%$ ;  $C_L = 2\text{pF}$ ,  $R_S = 33.2\Omega$ ,  $R_P = 49.9\Omega$ ,  $I_{REF} = 475\mu\text{A}$

PARAMETER	SYMBOL	CONDITIONS	MIN	TYP	MAX	UNITS	NOTES
Current Source Output Impedance	$Z_{O1}$	$V_O = V_x$	3000			$\Omega$	1
Voltage High	VHigh	Statistical measurement on single ended signal using oscilloscope math function.	660		850	mV	1,3
Voltage Low	VLow		-150		150		1,3
Max Voltage	Vovs	Measurement on single ended signal using absolute value.			1150	mV	1
Min Voltage	Vuds		-300				1
Crossing Voltage (abs)	Vcross(abs)		250		550	mV	1
Crossing Voltage (var)	d-Vcross	Variation of crossing over all edges			140	mV	1
Long Accuracy	ppm	see Tperiod min-max values			0	ppm	1,2
Average period	Tperiod	200MHz nominal	4.9985		5.0015	ns	2
		200MHz spread	4.9985		5.0266	ns	2
		166.66MHz nominal	5.9982		6.0018	ns	2
		166.66MHz spread	5.9982		6.0320	ns	2
		133.33MHz nominal	7.4978		7.5023	ns	2
		133.33MHz spread	7.4978		5.4000	ns	2
		100.00MHz nominal	9.9970		10.0030	ns	2
		100.00MHz spread	9.9970		10.0533	ns	2
Absolute min period	$T_{absmin}$	200MHz nominal	4.8735			ns	1,2
		166.66MHz nominal/spread	5.8732			ns	1,2
		133.33MHz nominal/spread	7.3728			ns	1,2
		100.00MHz nominal/spread	9.8720			ns	1,2
Rise Time	$t_r$	$V_{OL} = 0.175\text{V}$ , $V_{OH} = 0.525\text{V}$	175		700	ps	1
Fall Time	$t_f$	$V_{OH} = 0.525\text{V}$ , $V_{OL} = 0.175\text{V}$	175		700	ps	1
Rise Time Variation	$d-t_r$				125	ps	1
Fall Time Variation	$d-t_f$				125	ps	1
Duty Cycle	$d_{t3}$	Measurement from differential waveform	45		55	%	1
Skew	$t_{sk3}$	$V_T = 50\%$			50	ps	1
Jitter, Cycle to cycle	$t_{jyc-cyc}$	PLL mode, Measurement from differential waveform			50	ps	1
		BYPASS mode as additive jitter			50	ps	1

<sup>1</sup>Guaranteed by design and characterization, not 100% tested in production.

<sup>2</sup>All Long Term Accuracy and Clock Period specifications are guaranteed with the assumption that the input clock complies with CK409/CK410 accuracy requirements

<sup>3</sup> $I_{REF} = V_{DD}/(3 \times R_R)$ . For  $R_R = 475\Omega$  (1%),  $I_{REF} = 2.32\text{mA}$ .  $I_{OH} = 6 \times I_{REF}$  and  $V_{OH} = 0.7\text{V}$  @  $Z_O = 50\Omega$ .

## General SMBus serial interface information for the ICS9DB108

### How to Write:

- Controller (host) sends a start bit.
- Controller (host) sends the write address  $DC_{(h)}$
- ICS clock will **acknowledge**
- Controller (host) sends the beginning byte location = N
- ICS clock will **acknowledge**
- Controller (host) sends the data byte count = X
- ICS clock will **acknowledge**
- Controller (host) starts sending **Byte N through Byte N + X - 1**
- ICS clock will **acknowledge** each byte **one at a time**
- Controller (host) sends a Stop bit

Controller (Host)		ICS (Slave/Receiver)
T	starT bit	
Slave Address $DC_{(h)}$		
WR	WRite	
		ACK
Beginning Byte = N		
		ACK
Data Byte Count = X		
		ACK
Beginning Byte N	X Byte	
◊		ACK
◊		◊
◊		◊
Byte N + X - 1		◊
		ACK
P	stoP bit	

### How to Read:

- Controller (host) will send start bit.
- Controller (host) sends the write address  $DC_{(h)}$
- ICS clock will **acknowledge**
- Controller (host) sends the beginning byte location = N
- ICS clock will **acknowledge**
- Controller (host) will send a separate start bit.
- Controller (host) sends the read address  $DD_{(h)}$
- ICS clock will **acknowledge**
- ICS clock will send the data byte count = X
- ICS clock sends **Byte N + X - 1**
- ICS clock sends **Byte 0 through byte X (if  $X_{(h)}$  was written to byte 8).**
- Controller (host) will need to acknowledge each byte
- Controller (host) will send a not acknowledge bit
- Controller (host) will send a stop bit

Controller (Host)		ICS (Slave/Receiver)	
T	starT bit		
Slave Address $DC_{(h)}$			
WR	WRite		
		ACK	
Beginning Byte = N			
		ACK	
RT	Repeat starT		
Slave Address $DD_{(h)}$			
RD	ReaD		
		ACK	
		Data Byte Count = X	
ACK			
		X Byte	
ACK			Beginning Byte N
◊			◊
◊			◊
◊			◊
		Byte N + X - 1	
N	Not acknowledge		
P	stoP bit		



**SMBus Table: Frequency Select Register, READ/WRITE ADDRESS (DC/DD)**

Byte 0	Pin #	Name	Control Function	Type	0	1	PWD
Bit 7	-	PD#	drive mode	RW	driven	Hi-Z	0
Bit 6	-	SRC_Stop#	drive mode	RW	driven	Hi-Z	0
Bit 5	-	Reserved		RW	Reserved		X
Bit 4	-	Reserved		RW	Reserved		X
Bit 3	-	Reserved		RW	Reserved		X
Bit 2	-	PLL_BW#	adjust	RW	High BW	Low BW	1
Bit 1	-	BYPASS#/PLL		RW	fan-out	ZDB	1
Bit 0	-	SRC_DIV#		RW	x/2	1x	1

**SMBus Table: Output Control Register**

Byte 1	Pin #	Name	Control Function	Type	0	1	PWD
Bit 7	42,41	DIF_7	Output Control	RW	Disable	Enable	1
Bit 6	38,37	DIF_6	Output Control	RW	Disable	Enable	1
Bit 5	34,33	DIF_5	Output Control	RW	Disable	Enable	1
Bit 4	30,29	DIF_4	Output Control	RW	Disable	Enable	1
Bit 3	20,21	DIF_3	Output Control	RW	Disable	Enable	1
Bit 2	16,17	DIF_2	Output Control	RW	Disable	Enable	1
Bit 1	12,13	DIF_1	Output Control	RW	Disable	Enable	1
Bit 0	8,9	DIF_0	Output Control	RW	Disable	Enable	1





**SMBus Table: Output Control Register**

Byte 2		Pin #	Name	Control Function	Type	0	1	PWD
Bit 7		42,41	DIF_7	Output Control	RW	Reserved		0
Bit 6		38,37	DIF_6	Output Control	RW	Free-run	Stoppable	0
Bit 5		34,33	DIF_5	Output Control	RW	Free-run	Stoppable	0
Bit 4		30,29	DIF_4	Output Control	RW	Reserved		0
Bit 3		20,21	DIF_3	Output Control	RW	Reserved		0
Bit 2		16,17	DIF_2	Output Control	RW	Free-run	Stoppable	0
Bit 1		12,13	DIF_1	Output Control	RW	Free-run	Stoppable	0
Bit 0		8,9	DIF_0	Output Control	RW	Reserved		0

**SMBus Table: Output Control Register**

Byte 3		Pin #	Name	Control Function	Type	0	1	PWD
Bit 7				Reserved	RW	Reserved		X
Bit 6				Reserved	RW	Reserved		X
Bit 5				Reserved	RW	Reserved		X
Bit 4				Reserved	RW	Reserved		X
Bit 3				Reserved	RW	Reserved		X
Bit 2				Reserved	RW	Reserved		X
Bit 1				Reserved	RW	Reserved		X
Bit 0				Reserved	RW	Reserved		X

**SMBus Table: Vendor & Revision ID Register**

Byte 4		Pin #	Name	Control Function	Type	0	1	PWD
Bit 7		-	RID3	REVISION ID	R	-	-	0
Bit 6		-	RID2		R	-	-	0
Bit 5		-	RID1		R	-	-	0
Bit 4		-	RID0		R	-	-	1
Bit 3		-	VID3	VENDOR ID	R	-	-	0
Bit 2		-	VID2		R	-	-	0
Bit 1		-	VID1		R	-	-	0
Bit 0		-	VID0		R	-	-	1



SMBus Table: DEVICE ID

Byte 5		Pin #	Name	Control Function	Type	0	1	PWD
Bit 7	-		Device ID 7 (MSB)		RW	Reserved		0
Bit 6	-		Device ID 6		RW	Reserved		0
Bit 5	-		Device ID 5		RW	Reserved		0
Bit 4	-		Device ID 4		RW	Reserved		0
Bit 3	-		Device ID 3		RW	Reserved		1
Bit 2	-		Device ID 2		RW	Reserved		0
Bit 1	-		Device ID 1		RW	Reserved		0
Bit 0	-		Device ID 0		RW	Reserved		0

SMBus Table: Byte Count Register

Byte 6		Pin #	Name	Control Function	Type	0	1	PWD
Bit 7	-		BC7	Writing to this register configures how many bytes will be read back.	RW	-	-	0
Bit 6	-		BC6		RW	-	-	0
Bit 5	-		BC5		RW	-	-	0
Bit 4	-		BC4		RW	-	-	0
Bit 3	-		BC3		RW	-	-	0
Bit 2	-		BC2		RW	-	-	1
Bit 1	-		BC1		RW	-	-	0
Bit 0	-		BC0		RW	-	-	1

### PD#, Power Down

The PD# pin cleanly shuts off all clocks and places the device into a power saving mode. PD# must be asserted before shutting off the input clock or power to insure an orderly shutdown. PD is asynchronous active-low input for both powering down the device and powering up the device. When PD# is asserted, all clocks will be driven high, or tri-stated (depending on the PD# drive mode and Output control bits) before the PLL is shut down.

### PD# Assertion

When PD# is sampled low by two consecutive rising edges of DIF#, all DIF outputs must be held High, or tri-stated (depending on the PD# drive mode and Output control bits) on the next High-Low transition of the DIF# outputs. When the PD# drive mode bit is set to '0', all clock outputs will be held with DIF driven High with  $2 \times I_{REF}$  and DIF# tri-stated. If the PD# drive mode bit is set to '1', both DIF and DIF# are tri-stated.

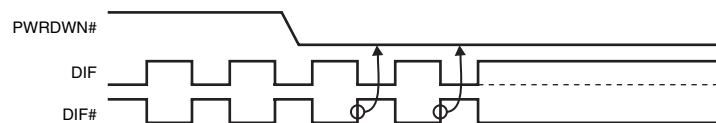

### PD# De-assertion

Power-up latency is less than 1 ms. This is the time from de-assertion of the PD# pin, or VDD reaching 3.3V, or the time from valid SRC\_IN clocks until the time that stable clocks are output from the device (PLL Locked). If the PD# drive mode bit is set to '1', all the DIF outputs must driven to a voltage of >200 mV within 300 ms of PD# de-assertion.

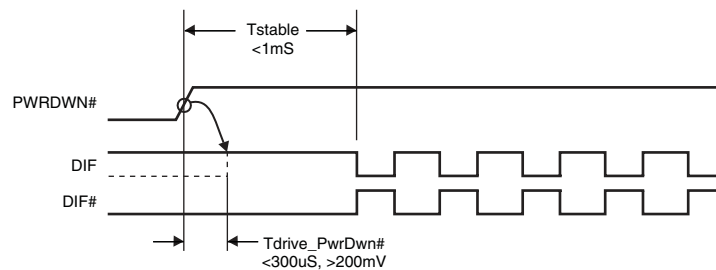

### SRC\_STOP#

The SRC\_STOP# signal is an active-low asynchronous input that cleanly stops and starts the DIF outputs. A valid clock must be present on SRC\_IN for this input to work properly. The SRC\_STOP# signal is de-bounced and must remain stable for two consecutive rising edges of DIF# to be recognized as a valid assertion or de-assertion.

### SRC\_STOP# - Assertion

Asserting SRC\_STOP# causes all DIF outputs to stop after their next transition (if the control register settings allow the output to stop). When the SRC\_STOP# drive bit is '0', the final state of all stopped DIF outputs is DIF = High and DIF# = Low. There is no change in output drive current. DIF is driven with  $6 \times I_{REF}$ . DIF# is not driven, but pulled low by the termination. When the SRC\_STOP# drive bit is '1', the final state of all DIF output pins is Low. Both DIF and DIF# are not driven.

### SRC\_STOP# - De-assertion (transition from '0' to '1')

All stopped differential outputs resume normal operation in a glitch-free manner. The de-assertion latency to active outputs is 2-6 DIF clock periods, with all DIF outputs resuming simultaneously. If the SRC\_STOP# drive control bit is '1' (tri-state), all stopped DIF outputs must be driven High (>200 mV) within 10 ns of de-assertion.

#### SRC\_STOP\_1 (SRC\_Stop = Driven, PD = Driven)

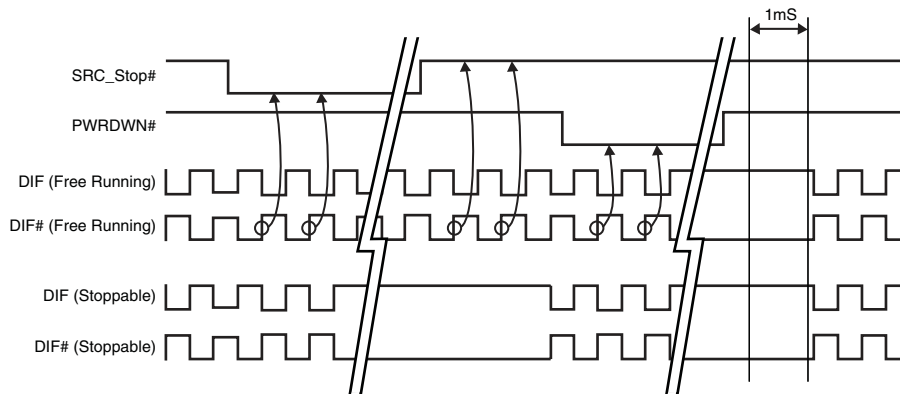

#### SRC\_STOP\_2 (SRC\_Stop = Tri-state, PD = Driven)

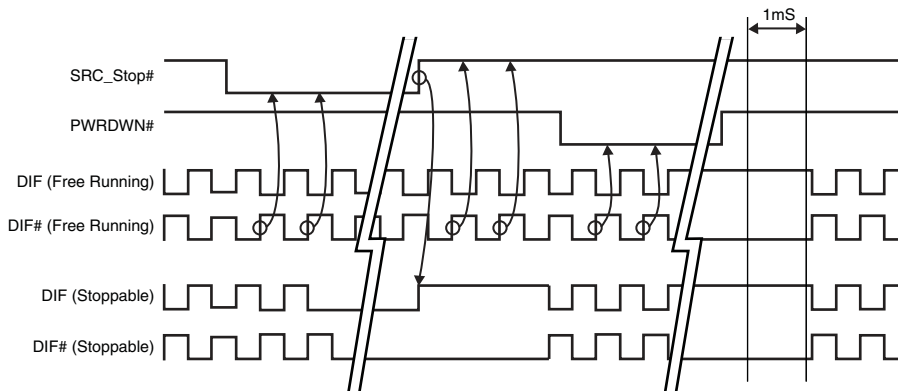

**SRC\_STOP\_3 (SRC\_Stop = Driven, PD = Tristate)**

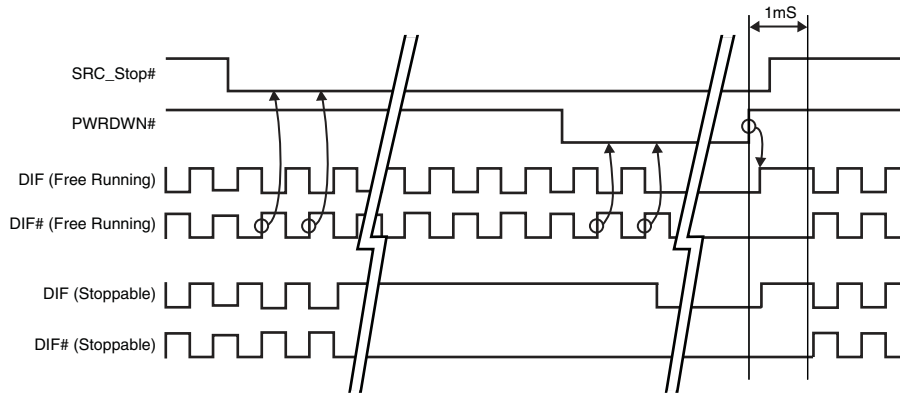

**SRC\_STOP\_4 (SRC\_Stop = Tristate, PD = Tristate)**

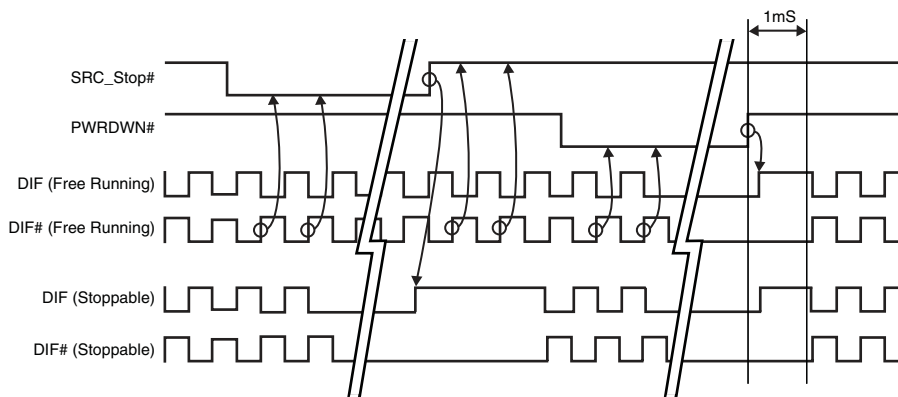

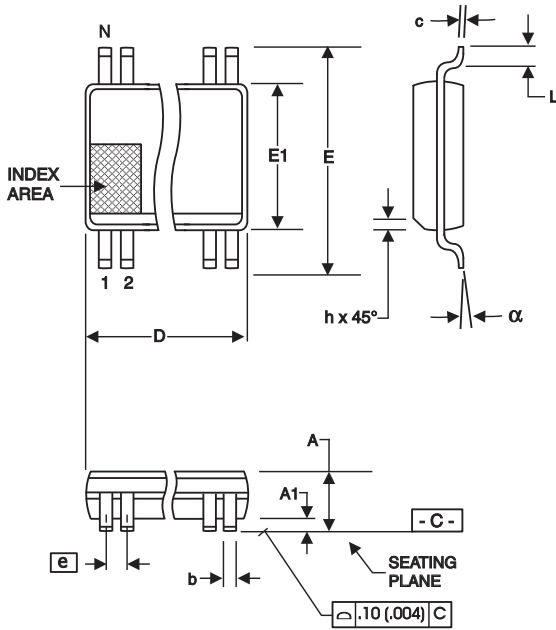

SYMBOL	In Millimeters COMMON DIMENSIONS		In Inches COMMON DIMENSIONS	
	MIN	MAX	MIN	MAX
A	2.41	2.80	.095	.110
A1	0.20	0.40	.008	.016
b	0.20	0.34	.008	.0135
c	0.13	0.25	.005	.010
D	SEE VARIATIONS		SEE VARIATIONS	
E	10.03	10.68	.395	.420
E1	7.40	7.60	.291	.299
e	0.635 BASIC		0.025 BASIC	
h	0.38	0.64	.015	.025
L	0.50	1.02	.020	.040
N	SEE VARIATIONS		SEE VARIATIONS	
alpha	0°	8°	0°	8°

VARIATIONS

N	D mm.		D (inch)	
	MIN	MAX	MIN	MAX
48	15.75	16.00	.620	.630

Reference Doc.: JEDEC Publication 95, MO-118

10-0034

## Ordering Information

**9DB108yFLxT**

Example:

**XXXX y F Lx T**

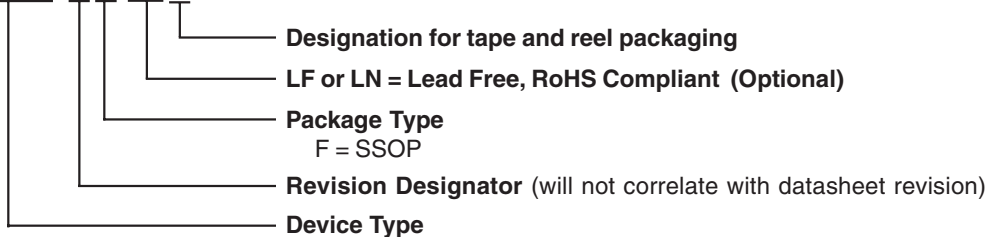

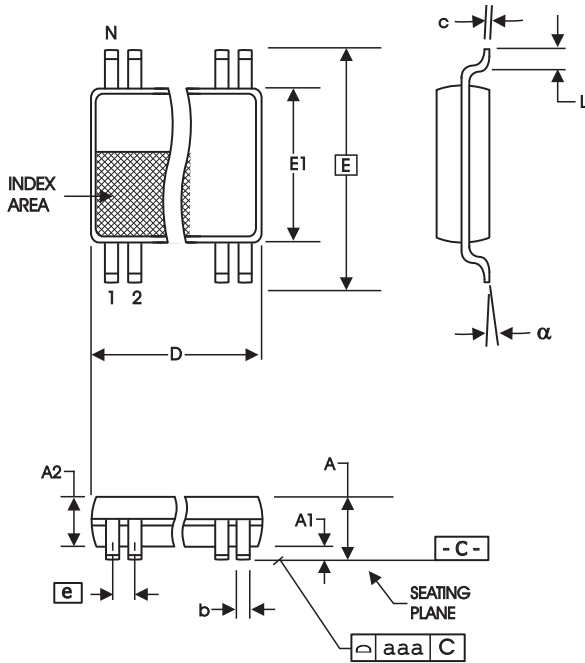

**48-Lead, 6.10 mm. Body, 0.50 mm. Pitch TSSOP**  
(240 mil) (20 mil)

SYMBOL	In Millimeters COMMON DIMENSIONS		In Inches COMMON DIMENSIONS	
	MIN	MAX	MIN	MAX
A	--	1.20	--	.047
A1	0.05	0.15	.002	.006
A2	0.80	1.05	.032	.041
b	0.17	0.27	.007	.011
c	0.09	0.20	.0035	.008
D	SEE VARIATIONS		SEE VARIATIONS	
E	8.10 BASIC		0.319 BASIC	
E1	6.00	6.20	.236	.244
e	0.50 BASIC		0.020 BASIC	
L	0.45	0.75	.018	.030
N	SEE VARIATIONS		SEE VARIATIONS	
a	0°	8°	0°	8°
aaa	--	0.10	--	.004

**VARIATIONS**

N	D mm.		D (inch)	
	MIN	MAX	MIN	MAX
48	12.40	12.60	.488	.496

Reference Doc.: JEDEC Publication 95, MO-153

10-0039

**Ordering Information**

**9DB108yGLxT**

Example:

**XXXX y G Lx T**

- Designation for tape and reel packaging
- LF or LN = Lead Free, RoHS Compliant (Optional)
- Package Type  
G = TSSOP
- Revision Designator (will not correlate with datasheet revision)
- Device Type (consists of 3 to 7 digit numbers)



**Revision History**

<b>Rev.</b>	<b>Issue Date</b>	<b>Description</b>	<b>Page #</b>
E	10/26/2005	Updated LF Ordering Information to LF or LN.	14, 15
F	12/17/2000	Updated SMBus Serial Interface Information.	7
G	12/2/2008	removed Ics prefix from ordering information	14-15





Компания «ЭлектроПласт» предлагает заключение долгосрочных отношений при поставках импортных электронных компонентов на взаимовыгодных условиях!

Наши преимущества:

- Оперативные поставки широкого спектра электронных компонентов отечественного и импортного производства напрямую от производителей и с крупнейших мировых складов;
- Поставка более 17-ти миллионов наименований электронных компонентов;
- Поставка сложных, дефицитных, либо снятых с производства позиций;
- Оперативные сроки поставки под заказ (от 5 рабочих дней);
- Экспресс доставка в любую точку России;
- Техническая поддержка проекта, помощь в подборе аналогов, поставка прототипов;
- Система менеджмента качества сертифицирована по Международному стандарту ISO 9001;
- Лицензия ФСБ на осуществление работ с использованием сведений, составляющих государственную тайну;
- Поставка специализированных компонентов (Xilinx, Altera, Analog Devices, Intersil, Interpoint, Microsemi, Aeroflex, Peregrine, Syfer, Eurofarad, Texas Instrument, Miteq, Cobham, E2V, MA-COM, Hittite, Mini-Circuits, General Dynamics и др.);

Помимо этого, одним из направлений компании «ЭлектроПласт» является направление «Источники питания». Мы предлагаем Вам помощь Конструкторского отдела:

- Подбор оптимального решения, техническое обоснование при выборе компонента;
- Подбор аналогов;
- Консультации по применению компонента;
- Поставка образцов и прототипов;
- Техническая поддержка проекта;
- Защита от снятия компонента с производства.



#### Как с нами связаться

**Телефон:** 8 (812) 309 58 32 (многоканальный)

**Факс:** 8 (812) 320-02-42

**Электронная почта:** [org@eplast1.ru](mailto:org@eplast1.ru)

**Адрес:** 198099, г. Санкт-Петербург, ул. Калинина, дом 2, корпус 4, литера А.