

32-bit Arm<sup>®</sup> Cortex<sup>®</sup>-M7 480MHz MCUs, 128 Kbyte Flash,  
1 Mbyte RAM, 46 com. and analog interfaces, crypto

Datasheet - production data

## Features

### Core

- 32-bit Arm<sup>®</sup> Cortex<sup>®</sup>-M7 core with double-precision FPU and L1 cache: 16 Kbytes of data and 16 Kbytes of instruction cache; frequency up to 480 MHz, MPU, 1027 DMIPS/2.14 DMIPS/MHz (Dhystone 2.1), and DSP instructions

### Memories

- 128 Kbytes of Flash memory
- 1 Mbyte of RAM: 192 Kbytes of TCM RAM (inc. 64 Kbytes of ITCM RAM + 128 Kbytes of DTCM RAM for time critical routines), 864 Kbytes of user SRAM, and 4 Kbytes of SRAM in Backup domain
- Dual mode Quad-SPI memory interface running up to 133 MHz
- Flexible external memory controller with up to 32-bit data bus:
  - SRAM, PSRAM, NOR Flash memory clocked up to 133 MHz in synchronous mode
  - SDRAM/LPSDR SDRAM
  - 8/16-bit NAND Flash memories
- CRC calculation unit

### Security

- ROP, PC-ROP, active tamper, secure firmware upgrade support, Secure access mode

### General-purpose input/outputs

- Up to 168 I/O ports with interrupt capability

### Reset and power management

- 3 separate power domains which can be independently clock-gated or switched off:
  - D1: high-performance capabilities

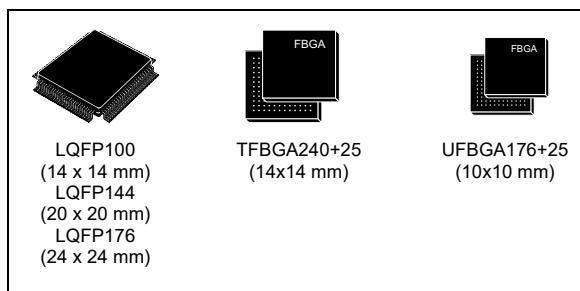

- D2: communication peripherals and timers
- D3: reset/clock control/power management
- 1.62 to 3.6 V application supply and I/Os
- POR, PDR, PVD and BOR
- Dedicated USB power embedding a 3.3 V internal regulator to supply the internal PHYs
- Embedded regulator (LDO) with configurable scalable output to supply the digital circuitry
- Voltage scaling in Run and Stop mode (6 configurable ranges)
- Backup regulator (~0.9 V)
- Voltage reference for analog peripheral/V<sub>REF+</sub>
- Low-power modes: Sleep, Stop, Standby and V<sub>BAT</sub> supporting battery charging

### Low-power consumption

- V<sub>BAT</sub> battery operating mode with charging capability
- CPU and domain power state monitoring pins
- 2.95 µA in Standby mode (Backup SRAM OFF, RTC/LSE ON)

### Clock management

- Internal oscillators: 64 MHz HSI, 48 MHz HSI48, 4 MHz CSI, 32 kHz LSI
- External oscillators: 4-48 MHz HSE, 32.768 kHz LSE
- 3× PLLs (1 for the system clock, 2 for kernel clocks) with Fractional mode

**Interconnect matrix**

- 3 bus matrices (1 AXI and 2 AHB)
- Bridges (5× AHB2-APB, 2× AXI2-AHB)

**4 DMA controllers to unload the CPU**

- 1× high-speed master direct memory access controller (MDMA) with linked list support
- 2× dual-port DMAs with FIFO
- 1× basic DMA with request router capabilities

**Up to 35 communication peripherals**

- 4× I2Cs FM+ interfaces (SMBus/PMBus)
- 4× USARTs/4× UARTs (ISO7816 interface, LIN, IrDA, up to 12.5 Mbit/s) and 1x LPUART
- 6× SPIs, 3 with muxed duplex I2S audio class accuracy via internal audio PLL or external clock, 1x I2S in LP domain (up to 150 MHz)
- 4× SAIs (serial audio interface)
- SPDIFRX interface
- SWPMI single-wire protocol master I/F
- MDIO Slave interface
- 2× SD/SDIO/MMC interfaces (up to 125 MHz)
- 2× CAN controllers: 2 with CAN FD, 1 with time-triggered CAN (TT-CAN)
- 2× USB OTG interfaces (1FS, 1HS/FS) crystal-less solution with LPM and BCD
- Ethernet MAC interface with DMA controller
- HDMI-CEC
- 8- to 14-bit camera interface (up to 80 MHz)

**11 analog peripherals**

- 3× ADCs with 16-bit max. resolution (up to 36 channels, up to 3.6 MSPS)
- 1× temperature sensor
- 2× 12-bit D/A converters (1 MHz)
- 2× ultra-low-power comparators
- 2× operational amplifiers (7.3 MHz bandwidth)
- 1× digital filters for sigma delta modulator (DFSDM) with 8 channels/4 filters

**Graphics**

- LCD-TFT controller up to XGA resolution

- Chrom-ART graphical hardware Accelerator (DMA2D) to reduce CPU load
- Hardware JPEG Codec

**Up to 22 timers and watchdogs**

- 1× high-resolution timer (2.1 ns max resolution)
- 2× 32-bit timers with up to 4 IC/OC/PWM or pulse counter and quadrature (incremental) encoder input (up to 240 MHz)
- 2× 16-bit advanced motor control timers (up to 240 MHz)
- 10× 16-bit general-purpose timers (up to 240 MHz)
- 5× 16-bit low-power timers (up to 240 MHz)
- 2× watchdogs (independent and window)
- 1× SysTick timer
- RTC with sub-second accuracy and hardware calendar

**Cryptographic acceleration**

- AES 128, 192, 256, TDES,
- HASH (MD5, SHA-1, SHA-2), HMAC
- True random number generators

**Debug mode**

- SWD & JTAG interfaces
- 4-Kbyte Embedded Trace Buffer

**96-bit unique ID****All packages are ECOPACK2 compliant**

# Contents

<b>1</b>	<b>Introduction</b> .....	<b>16</b>
<b>2</b>	<b>Description</b> .....	<b>17</b>
<b>3</b>	<b>Functional overview</b> .....	<b>22</b>
3.1	Arm® Cortex®-M7 with FPU .....	22
3.2	Memory protection unit (MPU) .....	22
3.3	Memories .....	23
3.3.1	Embedded Flash memory .....	23
3.3.2	Secure access mode .....	23
3.3.3	Embedded SRAM .....	24
3.4	Boot modes .....	24
3.5	Power supply management .....	25
3.5.1	Power supply scheme .....	25
3.5.2	Power supply supervisor .....	26
3.5.3	Voltage regulator .....	27
3.6	Low-power strategy .....	27
3.7	Reset and clock controller (RCC) .....	28
3.7.1	Clock management .....	28
3.7.2	System reset sources .....	29
3.8	General-purpose input/outputs (GPIOs) .....	29
3.9	Bus-interconnect matrix .....	29
3.10	DMA controllers .....	31
3.11	Chrom-ART Accelerator (DMA2D) .....	31
3.12	Nested vectored interrupt controller (NVIC) .....	32
3.13	Extended interrupt and event controller (EXTI) .....	32
3.14	Cyclic redundancy check calculation unit (CRC) .....	32
3.15	Flexible memory controller (FMC) .....	33
3.16	Quad-SPI memory interface (QUADSPI) .....	33
3.17	Analog-to-digital converters (ADCs) .....	33
3.18	Temperature sensor .....	34
3.19	V <sub>BAT</sub> operation .....	34

3.20	Digital-to-analog converters (DAC)	35
3.21	Ultra-low-power comparators (COMP)	35
3.22	Operational amplifiers (OPAMP)	35
3.23	Digital filter for sigma-delta modulators (DFSDM)	36
3.24	Digital camera interface (DCMI)	37
3.25	LCD-TFT controller	38
3.26	JPEG Codec (JPEG)	38
3.27	Random number generator (RNG)	38
3.28	Cryptographic acceleration (CRYP and HASH)	39
3.29	Timers and watchdogs	39
3.29.1	High-resolution timer (HRTIM1)	41
3.29.2	Advanced-control timers (TIM1, TIM8)	42
3.29.3	General-purpose timers (TIMx)	42
3.29.4	Basic timers TIM6 and TIM7	43
3.29.5	Low-power timers (LPTIM1, LPTIM2, LPTIM3, LPTIM4, LPTIM5)	43
3.29.6	Independent watchdog	43
3.29.7	Window watchdog	43
3.29.8	SysTick timer	43
3.30	Real-time clock (RTC), backup SRAM and backup registers	44
3.31	Inter-integrated circuit interface (I <sup>2</sup> C)	45
3.32	Universal synchronous/asynchronous receiver transmitter (USART)	45
3.33	Low-power universal asynchronous receiver transmitter (LPUART)	46
3.34	Serial peripheral interfaces (SPI)/integrated interchip sound interfaces (I2S)	47
3.35	Serial audio interfaces (SAI)	47
3.36	SPDIFRX Receiver Interface (SPDIFRX)	48
3.37	Single wire protocol master interface (SWPMI)	48
3.38	Management Data Input/Output (MDIO) slaves	49
3.39	SD/SDIO/MMC card host interfaces (SDMMC)	49
3.40	Controller area network (FDCAN1, FDCAN2)	49
3.41	Universal serial bus on-the-go high-speed (OTG_HS)	50
3.42	Ethernet MAC interface with dedicated DMA controller (ETH)	50
3.43	High-definition multimedia interface (HDMI) - consumer electronics control (CEC)	51
3.44	Debug infrastructure	51

<b>4</b>	<b>Memory mapping</b> .....	<b>52</b>
<b>5</b>	<b>Pin descriptions</b> .....	<b>53</b>
<b>6</b>	<b>Electrical characteristics (rev Y)</b> .....	<b>94</b>
6.1	Parameter conditions .....	94
6.1.1	Minimum and maximum values .....	94
6.1.2	Typical values .....	94
6.1.3	Typical curves .....	94
6.1.4	Loading capacitor .....	94
6.1.5	Pin input voltage .....	94
6.1.6	Power supply scheme .....	95
6.1.7	Current consumption measurement .....	96
6.2	Absolute maximum ratings .....	96
6.3	Operating conditions .....	98
6.3.1	General operating conditions .....	98
6.3.2	VCAP external capacitor .....	99
6.3.3	Operating conditions at power-up / power-down .....	99
6.3.4	Embedded reset and power control block characteristics .....	100
6.3.5	Embedded reference voltage .....	101
6.3.6	Supply current characteristics .....	102
6.3.7	Wakeup time from low-power modes .....	115
6.3.8	External clock source characteristics .....	116
6.3.9	Internal clock source characteristics .....	120
6.3.10	PLL characteristics .....	122
6.3.11	Memory characteristics .....	124
6.3.12	EMC characteristics .....	126
6.3.13	Absolute maximum ratings (electrical sensitivity) .....	127
6.3.14	I/O current injection characteristics .....	128
6.3.15	I/O port characteristics .....	129
6.3.16	NRST pin characteristics .....	136
6.3.17	FMC characteristics .....	137
6.3.18	Quad-SPI interface characteristics .....	157
6.3.19	Delay block (DLYB) characteristics .....	159
6.3.20	16-bit ADC characteristics .....	159
6.3.21	DAC electrical characteristics .....	165
6.3.22	Voltage reference buffer characteristics .....	168

6.3.23	Temperature sensor characteristics	169
6.3.24	Temperature and V <sub>BAT</sub> monitoring	170
6.3.25	Voltage booster for analog switch	171
6.3.26	Comparator characteristics	172
6.3.27	Operational amplifier characteristics	173
6.3.28	Digital filter for Sigma-Delta Modulators (DFSDM) characteristics	176
6.3.29	Camera interface (DCMI) timing specifications	178
6.3.30	LCD-TFT controller (LTDC) characteristics	179
6.3.31	Timer characteristics	181
6.3.32	Communications interfaces	182
6.3.33	JTAG/SWD interface characteristics	196
<b>7</b>	<b>Electrical characteristics (rev V)</b>	<b>199</b>
7.1	Parameter conditions	199
7.1.1	Minimum and maximum values	199
7.1.2	Typical values	199
7.1.3	Typical curves	199
7.1.4	Loading capacitor	199
7.1.5	Pin input voltage	199
7.1.6	Power supply scheme	200
7.1.7	Current consumption measurement	201
7.2	Absolute maximum ratings	201
7.3	Operating conditions	203
7.3.1	General operating conditions	203
7.3.2	VCAP external capacitor	205
7.3.3	Operating conditions at power-up / power-down	205
7.3.4	Embedded reset and power control block characteristics	206
7.3.5	Embedded reference voltage	207
7.3.6	Supply current characteristics	208
7.3.7	Wakeup time from low-power modes	220
7.3.8	External clock source characteristics	221
7.3.9	Internal clock source characteristics	225
7.3.10	PLL characteristics	228
7.3.11	Memory characteristics	230
7.3.12	EMC characteristics	231
7.3.13	Absolute maximum ratings (electrical sensitivity)	233
7.3.14	I/O current injection characteristics	234

---

7.3.15	I/O port characteristics	235
7.3.16	NRST pin characteristics	242
7.3.17	FMC characteristics	242
7.3.18	Quad-SPI interface characteristics	264
7.3.19	Delay block (DLYB) characteristics	266
7.3.20	16-bit ADC characteristics	267
7.3.21	DAC characteristics	275
7.3.22	Voltage reference buffer characteristics	279
7.3.23	Temperature sensor characteristics	280
7.3.24	Temperature and V <sub>BAT</sub> monitoring	281
7.3.25	Voltage booster for analog switch	281
7.3.26	Comparator characteristics	282
7.3.27	Operational amplifier characteristics	283
7.3.28	Digital filter for Sigma-Delta Modulators (DFSDM) characteristics	285
7.3.29	Camera interface (DCMI) timing specifications	288
7.3.30	LCD-TFT controller (LTDC) characteristics	289
7.3.31	Timer characteristics	291
7.3.32	Communication interfaces	291
<b>8</b>	<b>Package information</b>	<b>311</b>
8.1	LQFP100 package information	311
8.2	LQFP144 package information	315
8.3	LQFP176 package information	319
8.4	UFBGA176+25 package information	323
8.5	TFBGA240+25 package information	326
8.6	Thermal characteristics	329
8.6.1	Reference document	330
<b>9</b>	<b>Ordering information</b>	<b>331</b>
<b>10</b>	<b>Revision history</b>	<b>332</b>

## List of tables

Table 1.	STM32H750xB features and peripheral counts . . . . .	18
Table 2.	System vs domain low-power mode . . . . .	28
Table 3.	DFSDM implementation . . . . .	37
Table 4.	Timer feature comparison . . . . .	39
Table 5.	USART features . . . . .	46
Table 6.	Legend/abbreviations used in the pinout table . . . . .	58
Table 7.	STM32H750xB pin/ball definition . . . . .	59
Table 8.	Port A alternate functions . . . . .	79
Table 9.	Port B alternate functions . . . . .	80
Table 10.	Port C alternate functions . . . . .	82
Table 11.	Port D alternate functions . . . . .	83
Table 12.	Port E alternate functions . . . . .	85
Table 13.	Port F alternate functions . . . . .	87
Table 14.	Port G alternate functions . . . . .	88
Table 15.	Port H alternate functions . . . . .	90
Table 16.	Port I alternate functions . . . . .	91
Table 17.	Port J alternate functions . . . . .	92
Table 18.	Port K alternate functions . . . . .	93
Table 19.	Voltage characteristics . . . . .	96
Table 20.	Current characteristics . . . . .	97
Table 21.	Thermal characteristics . . . . .	97
Table 22.	General operating conditions . . . . .	98
Table 23.	VCAP operating conditions . . . . .	99
Table 24.	Operating conditions at power-up / power-down (regulator ON) . . . . .	99
Table 25.	Reset and power control block characteristics . . . . .	100
Table 26.	Embedded reference voltage . . . . .	101
Table 27.	Internal reference voltage calibration values . . . . .	102
Table 28.	Typical and maximum current consumption in Run mode, code with data processing running from ITCM, regulator ON . . . . .	103
Table 29.	Typical and maximum current consumption in Run mode, code with data processing running from Flash memory, cache ON, regulator ON . . . . .	104
Table 30.	Typical and maximum current consumption in Run mode, code with data processing running from Flash memory, cache OFF, regulator ON . . . . .	104
Table 31.	Typical consumption in Run mode and corresponding performance versus code position . . . . .	105
Table 32.	Typical current consumption batch acquisition mode . . . . .	105
Table 33.	Typical and maximum current consumption in Sleep mode, regulator ON . . . . .	105
Table 34.	Typical and maximum current consumption in Stop mode, regulator ON . . . . .	106
Table 35.	Typical and maximum current consumption in Standby mode . . . . .	106
Table 36.	Typical and maximum current consumption in VBAT mode . . . . .	107
Table 37.	Peripheral current consumption in Run mode . . . . .	109
Table 38.	Peripheral current consumption in Stop, Standby and VBAT mode . . . . .	114
Table 39.	Low-power mode wakeup timings . . . . .	115
Table 40.	High-speed external user clock characteristics . . . . .	116
Table 41.	Low-speed external user clock characteristics . . . . .	117
Table 42.	4-48 MHz HSE oscillator characteristics . . . . .	118
Table 43.	Low-speed external user clock characteristics . . . . .	119
Table 44.	HSI48 oscillator characteristics . . . . .	120



Table 45.	HSI oscillator characteristics . . . . .	121
Table 46.	CSI oscillator characteristics . . . . .	121
Table 47.	LSI oscillator characteristics . . . . .	122
Table 48.	PLL characteristics (wide VCO frequency range) . . . . .	122
Table 49.	PLL characteristics (medium VCO frequency range) . . . . .	123
Table 50.	Flash memory characteristics . . . . .	124
Table 51.	Flash memory programming . . . . .	125
Table 52.	Flash memory endurance and data retention . . . . .	125
Table 53.	EMS characteristics . . . . .	126
Table 54.	EMI characteristics . . . . .	127
Table 55.	ESD absolute maximum ratings . . . . .	127
Table 56.	Electrical sensitivities . . . . .	128
Table 57.	I/O current injection susceptibility . . . . .	128
Table 58.	I/O static characteristics . . . . .	129
Table 59.	Output voltage characteristics for all I/Os except PC13, PC14, PC15 and PI8 . . . . .	131
Table 60.	Output voltage characteristics for PC13, PC14, PC15 and PI8 . . . . .	132
Table 61.	Output timing characteristics (HSLV OFF) . . . . .	133
Table 62.	Output timing characteristics (HSLV ON) . . . . .	135
Table 63.	NRST pin characteristics . . . . .	136
Table 64.	Asynchronous non-multiplexed SRAM/PSRAM/NOR read timings . . . . .	139
Table 65.	Asynchronous non-multiplexed SRAM/PSRAM/NOR read - NWAIT timings . . . . .	139
Table 66.	Asynchronous non-multiplexed SRAM/PSRAM/NOR write timings . . . . .	140
Table 67.	Asynchronous non-multiplexed SRAM/PSRAM/NOR write - NWAIT timings . . . . .	141
Table 68.	Asynchronous multiplexed PSRAM/NOR read timings . . . . .	142
Table 69.	Asynchronous multiplexed PSRAM/NOR read-NWAIT timings . . . . .	142
Table 70.	Asynchronous multiplexed PSRAM/NOR write timings . . . . .	143
Table 71.	Asynchronous multiplexed PSRAM/NOR write-NWAIT timings . . . . .	144
Table 72.	Synchronous multiplexed NOR/PSRAM read timings . . . . .	146
Table 73.	Synchronous multiplexed PSRAM write timings . . . . .	148
Table 74.	Synchronous non-multiplexed NOR/PSRAM read timings . . . . .	149
Table 75.	Synchronous non-multiplexed PSRAM write timings . . . . .	150
Table 76.	Switching characteristics for NAND Flash read cycles . . . . .	153
Table 77.	Switching characteristics for NAND Flash write cycles . . . . .	153
Table 78.	SDRAM read timings . . . . .	154
Table 79.	LPSDR SDRAM read timings . . . . .	155
Table 80.	SDRAM write timings . . . . .	156
Table 81.	LPSDR SDRAM write timings . . . . .	156
Table 82.	QUADSPI characteristics in SDR mode . . . . .	157
Table 83.	QUADSPI characteristics in DDR mode . . . . .	158
Table 84.	Dynamics characteristics: Delay Block characteristics . . . . .	159
Table 85.	ADC characteristics . . . . .	159
Table 86.	ADC accuracy . . . . .	161
Table 87.	DAC characteristics . . . . .	165
Table 88.	DAC accuracy . . . . .	166
Table 89.	VREFBUF characteristics . . . . .	168
Table 90.	Temperature sensor characteristics . . . . .	169
Table 91.	Temperature sensor calibration values . . . . .	170
Table 92.	V <sub>BAT</sub> monitoring characteristics . . . . .	170
Table 93.	V <sub>BAT</sub> charging characteristics . . . . .	170
Table 94.	Temperature monitoring characteristics . . . . .	170
Table 95.	Voltage booster for analog switch characteristics . . . . .	171
Table 96.	COMP characteristics . . . . .	172

Table 97.	OPAMP characteristics	173
Table 98.	DFSDM measured timing - 1.62-3.6 V	176
Table 99.	DCMI characteristics	178
Table 100.	LTDC characteristics	179
Table 101.	TIMx characteristics	181
Table 102.	Minimum i2c_ker_ck frequency in all I2C modes	182
Table 103.	I2C analog filter characteristics	182
Table 104.	SPI dynamic characteristics	183
Table 105.	I <sup>2</sup> S dynamic characteristics	186
Table 106.	SAI characteristics	188
Table 107.	MDIO Slave timing parameters	189
Table 108.	Dynamic characteristics: SD / MMC characteristics, VDD=2.7V to 3.6V	190
Table 109.	Dynamic characteristics: eMMC characteristics, VDD=1.71V to 1.9V	191
Table 110.	USB OTG_FS electrical characteristics	193
Table 111.	Dynamic characteristics: USB ULPI	193
Table 112.	Dynamics characteristics: Ethernet MAC signals for SMI	194
Table 113.	Dynamics characteristics: Ethernet MAC signals for RMII	195
Table 114.	Dynamics characteristics: Ethernet MAC signals for MII	196
Table 115.	Dynamics JTAG characteristics	197
Table 116.	Dynamics SWD characteristics	197
Table 117.	Voltage characteristics	201
Table 118.	Current characteristics	202
Table 119.	Thermal characteristics	202
Table 120.	General operating conditions	203
Table 121.	Supply voltage and maximum frequency configuration	204
Table 122.	VCAP operating conditions	205
Table 123.	Operating conditions at power-up / power-down (regulator ON)	205
Table 124.	Reset and power control block characteristics	206
Table 125.	Embedded reference voltage	207
Table 126.	Internal reference voltage calibration values	208
Table 127.	Typical and maximum current consumption in Run mode, code with data processing running from ITCM, LDO regulator ON	209
Table 128.	Typical and maximum current consumption in Run mode, code with data processing running from Flash memory, cache ON, LDO regulator ON	210
Table 129.	Typical and maximum current consumption in Run mode, code with data processing running from Flash memory, cache OFF, LDO regulator ON	210
Table 130.	Typical and maximum current consumption batch acquisition mode, LDO regulator ON	211
Table 131.	Typical and maximum current consumption in Stop, LDO regulator ON	211
Table 132.	Typical and maximum current consumption in Sleep mode, LDO regulator	212
Table 133.	Typical and maximum current consumption in Standby	212
Table 134.	Typical and maximum current consumption in VBAT mode	213
Table 135.	Peripheral current consumption in Run mode	215
Table 136.	Low-power mode wakeup timings	220
Table 137.	High-speed external user clock characteristics	221
Table 138.	Low-speed external user clock characteristics	222
Table 139.	4-48 MHz HSE oscillator characteristics	223
Table 140.	Low-speed external user clock characteristics	224
Table 141.	HSI48 oscillator characteristics	225
Table 142.	HSI oscillator characteristics	226

Table 143.	CSI oscillator characteristics . . . . .	226
Table 144.	LSI oscillator characteristics . . . . .	227
Table 145.	PLL characteristics (wide VCO frequency range) . . . . .	228
Table 146.	PLL characteristics (medium VCO frequency range) . . . . .	229
Table 147.	Flash memory characteristics . . . . .	230
Table 148.	Flash memory programming . . . . .	230
Table 149.	Flash memory endurance and data retention . . . . .	231
Table 150.	EMS characteristics . . . . .	231
Table 151.	EMI characteristics . . . . .	232
Table 152.	ESD absolute maximum ratings . . . . .	233
Table 153.	Electrical sensitivities . . . . .	233
Table 154.	I/O current injection susceptibility . . . . .	234
Table 155.	I/O static characteristics . . . . .	235
Table 156.	Output voltage characteristics for all I/Os except PC13, PC14, PC15 and PI8 . . . . .	237
Table 157.	Output voltage characteristics for PC13, PC14, PC15 and PI8 . . . . .	238
Table 158.	Output timing characteristics (HSLV OFF) . . . . .	239
Table 159.	Output timing characteristics (HSLV ON) . . . . .	241
Table 160.	NRST pin characteristics . . . . .	242
Table 161.	Asynchronous non-multiplexed SRAM/PSRAM/NOR read timings . . . . .	244
Table 162.	Asynchronous non-multiplexed SRAM/PSRAM/NOR read-NWAIT timings . . . . .	244
Table 163.	Asynchronous non-multiplexed SRAM/PSRAM/NOR write timings . . . . .	246
Table 164.	Asynchronous non-multiplexed SRAM/PSRAM/NOR write-NWAIT timings . . . . .	246
Table 165.	Asynchronous multiplexed PSRAM/NOR read timings . . . . .	248
Table 166.	Asynchronous multiplexed PSRAM/NOR read-NWAIT timings . . . . .	248
Table 167.	Asynchronous multiplexed PSRAM/NOR write timings . . . . .	249
Table 168.	Asynchronous multiplexed PSRAM/NOR write-NWAIT timings . . . . .	249
Table 169.	Synchronous multiplexed NOR/PSRAM read timings . . . . .	251
Table 170.	Synchronous multiplexed PSRAM write timings . . . . .	253
Table 171.	Synchronous non-multiplexed NOR/PSRAM read timings . . . . .	255
Table 172.	Synchronous non-multiplexed PSRAM write timings . . . . .	257
Table 173.	Switching characteristics for NAND Flash read cycles . . . . .	260
Table 174.	Switching characteristics for NAND Flash write cycles . . . . .	260
Table 175.	SDRAM read timings . . . . .	262
Table 176.	LPSDR SDRAM read timings . . . . .	262
Table 177.	SDRAM Write timings . . . . .	263
Table 178.	LPSDR SDRAM Write timings . . . . .	264
Table 179.	QUADSPI characteristics in SDR mode . . . . .	264
Table 180.	QUADSPI characteristics in DDR mode . . . . .	265
Table 181.	Delay Block characteristics . . . . .	266
Table 182.	ADC characteristics . . . . .	267
Table 183.	Minimum sampling time vs RAIN . . . . .	270
Table 184.	ADC accuracy . . . . .	272
Table 185.	DAC characteristics . . . . .	275
Table 186.	DAC accuracy . . . . .	277
Table 187.	VREFBUF characteristics . . . . .	279
Table 188.	Temperature sensor characteristics . . . . .	280
Table 189.	Temperature sensor calibration values . . . . .	280
Table 190.	V <sub>BAT</sub> monitoring characteristics . . . . .	281
Table 191.	V <sub>BAT</sub> charging characteristics . . . . .	281
Table 192.	Temperature monitoring characteristics . . . . .	281
Table 193.	Voltage booster for analog switch characteristics . . . . .	281
Table 194.	COMP characteristics . . . . .	282

Table 195.	Operational amplifier characteristics . . . . .	283
Table 196.	DFSDM measured timing - 1.62-3.6 V . . . . .	286
Table 197.	DCMI characteristics . . . . .	288
Table 198.	LTDC characteristics . . . . .	289
Table 199.	TIMx characteristics . . . . .	291
Table 200.	Minimum i2c_ker_ck frequency in all I2C modes . . . . .	292
Table 201.	I2C analog filter characteristics . . . . .	292
Table 202.	USART characteristics . . . . .	293
Table 203.	SPI characteristics . . . . .	295
Table 204.	I <sup>2</sup> S dynamic characteristics . . . . .	298
Table 205.	SAI characteristics . . . . .	300
Table 206.	MDIO Slave timing parameters . . . . .	302
Table 207.	Dynamics characteristics: SD / MMC characteristics, VDD=2.7 to 3.6 V . . . . .	303
Table 208.	Dynamics characteristics: eMMC characteristics VDD=1.71V to 1.9V . . . . .	304
Table 209.	Dynamics characteristics: USB ULPI . . . . .	306
Table 210.	Dynamics characteristics: Ethernet MAC signals for SMI . . . . .	307
Table 211.	Dynamics characteristics: Ethernet MAC signals for RMII . . . . .	308
Table 212.	Dynamics characteristics: Ethernet MAC signals for MII . . . . .	308
Table 213.	Dynamics JTAG characteristics . . . . .	309
Table 214.	Dynamics SWD characteristics: . . . . .	310
Table 215.	LQPF100 package mechanical data . . . . .	312
Table 216.	LQFP144 package mechanical data . . . . .	316
Table 217.	LQFP176 package mechanical data . . . . .	319
Table 218.	UFBGA176+25 package mechanical data . . . . .	323
Table 219.	UFBGA176+25 recommended PCB design rules (0.65 mm pitch BGA) . . . . .	324
Table 220.	TFBG240+25 ball package mechanical data . . . . .	327
Table 221.	TFBGA240+25 recommended PCB design rules (0.8 mm pitch) . . . . .	328
Table 222.	Thermal characteristics . . . . .	329
Table 223.	Document revision history . . . . .	332

## List of figures

Figure 1.	STM32H750xB block diagram	21
Figure 2.	Power-up/power-down sequence	26
Figure 3.	STM32H750xB bus matrix	30
Figure 4.	LQFP100 pinout	53
Figure 5.	LQFP144 pinout	54
Figure 6.	LQFP176 pinout	55
Figure 7.	UFBGA176+25 ballout	56
Figure 8.	TFBGA240+25 ballout	57
Figure 9.	Pin loading conditions	94
Figure 10.	Pin input voltage	94
Figure 11.	Power supply scheme	95
Figure 12.	Current consumption measurement scheme	96
Figure 13.	External capacitor $C_{EXT}$	99
Figure 14.	High-speed external clock source AC timing diagram	116
Figure 15.	Low-speed external clock source AC timing diagram	117
Figure 16.	Typical application with an 8 MHz crystal	119
Figure 17.	Typical application with a 32.768 kHz crystal	120
Figure 18.	VIL/VIH for all I/Os except BOOT0	130
Figure 19.	Recommended NRST pin protection	136
Figure 20.	Asynchronous non-multiplexed SRAM/PSRAM/NOR read waveforms	138
Figure 21.	Asynchronous non-multiplexed SRAM/PSRAM/NOR write waveforms	140
Figure 22.	Asynchronous multiplexed PSRAM/NOR read waveforms	141
Figure 23.	Asynchronous multiplexed PSRAM/NOR write waveforms	143
Figure 24.	Synchronous multiplexed NOR/PSRAM read timings	145
Figure 25.	Synchronous multiplexed PSRAM write timings	147
Figure 26.	Synchronous non-multiplexed NOR/PSRAM read timings	149
Figure 27.	Synchronous non-multiplexed PSRAM write timings	150
Figure 28.	NAND controller waveforms for read access	151
Figure 29.	NAND controller waveforms for write access	152
Figure 30.	NAND controller waveforms for common memory read access	152
Figure 31.	NAND controller waveforms for common memory write access	153
Figure 32.	SDRAM read access waveforms (CL = 1)	154
Figure 33.	SDRAM write access waveforms	155
Figure 34.	Quad-SPI timing diagram - SDR mode	158
Figure 35.	Quad-SPI timing diagram - DDR mode	158
Figure 36.	ADC accuracy characteristics (12-bit resolution)	162
Figure 37.	Typical connection diagram using the ADC	163
Figure 38.	Power supply and reference decoupling ( $V_{REF+}$ not connected to $V_{DDA}$ )	164
Figure 39.	Power supply and reference decoupling ( $V_{REF+}$ connected to $V_{DDA}$ )	164
Figure 40.	12-bit buffered /non-buffered DAC	168
Figure 41.	Channel transceiver timing diagrams	177
Figure 42.	DCMI timing diagram	178
Figure 43.	LCD-TFT horizontal timing diagram	180
Figure 44.	LCD-TFT vertical timing diagram	180
Figure 45.	SPI timing diagram - slave mode and CPHA = 0	184
Figure 46.	SPI timing diagram - slave mode and CPHA = 1 <sup>(1)</sup>	185
Figure 47.	SPI timing diagram - master mode <sup>(1)</sup>	185
Figure 48.	I <sup>2</sup> S slave timing diagram (Philips protocol) <sup>(1)</sup>	187

Figure 49.	I <sup>2</sup> S master timing diagram (Philips protocol) <sup>(1)</sup> . . . . .	187
Figure 50.	SAI master timing waveforms . . . . .	189
Figure 51.	SAI slave timing waveforms . . . . .	189
Figure 52.	MDIO Slave timing diagram . . . . .	190
Figure 53.	SDIO high-speed mode . . . . .	192
Figure 54.	SD default mode . . . . .	192
Figure 55.	DDR mode . . . . .	192
Figure 56.	ULPI timing diagram . . . . .	194
Figure 57.	Ethernet SMI timing diagram . . . . .	195
Figure 58.	Ethernet RMII timing diagram . . . . .	195
Figure 59.	Ethernet MII timing diagram . . . . .	196
Figure 60.	JTAG timing diagram . . . . .	198
Figure 61.	SWD timing diagram . . . . .	198
Figure 62.	Pin loading conditions . . . . .	199
Figure 63.	Pin input voltage . . . . .	199
Figure 64.	Power supply scheme . . . . .	200
Figure 65.	Current consumption measurement scheme . . . . .	201
Figure 66.	External capacitor C <sub>EXT</sub> . . . . .	205
Figure 67.	High-speed external clock source AC timing diagram . . . . .	221
Figure 68.	Low-speed external clock source AC timing diagram . . . . .	222
Figure 69.	Typical application with an 8 MHz crystal . . . . .	224
Figure 70.	Typical application with a 32.768 kHz crystal . . . . .	225
Figure 71.	VIL/VIH for all I/Os except BOOT0 . . . . .	236
Figure 72.	Recommended NRST pin protection . . . . .	242
Figure 73.	Asynchronous non-multiplexed SRAM/PSRAM/NOR read waveforms . . . . .	243
Figure 74.	Asynchronous non-multiplexed SRAM/PSRAM/NOR write waveforms . . . . .	245
Figure 75.	Asynchronous multiplexed PSRAM/NOR read waveforms . . . . .	247
Figure 76.	Synchronous multiplexed NOR/PSRAM read timings . . . . .	250
Figure 77.	Synchronous multiplexed PSRAM write timings . . . . .	252
Figure 78.	Synchronous non-multiplexed NOR/PSRAM read timings . . . . .	254
Figure 79.	Synchronous non-multiplexed PSRAM write timings . . . . .	256
Figure 80.	NAND controller waveforms for read access . . . . .	258
Figure 81.	NAND controller waveforms for write access . . . . .	259
Figure 82.	NAND controller waveforms for common memory read access . . . . .	259
Figure 83.	NAND controller waveforms for common memory write access . . . . .	260
Figure 84.	SDRAM read access waveforms (CL = 1) . . . . .	261
Figure 85.	SDRAM write access waveforms . . . . .	263
Figure 86.	Quad-SPI timing diagram - SDR mode . . . . .	266
Figure 87.	Quad-SPI timing diagram - DDR mode . . . . .	266
Figure 88.	ADC accuracy characteristics (12-bit resolution) . . . . .	273
Figure 89.	Typical connection diagram using the ADC . . . . .	273
Figure 90.	Power supply and reference decoupling (V <sub>REF+</sub> not connected to V <sub>DDA</sub> ) . . . . .	274
Figure 91.	Power supply and reference decoupling (V <sub>REF+</sub> connected to V <sub>DDA</sub> ) . . . . .	274
Figure 92.	12-bit buffered /non-buffered DAC . . . . .	278
Figure 93.	Channel transceiver timing diagrams . . . . .	287
Figure 94.	DCMI timing diagram . . . . .	288
Figure 95.	LCD-TFT horizontal timing diagram . . . . .	290
Figure 96.	LCD-TFT vertical timing diagram . . . . .	290
Figure 97.	USART timing diagram in Master mode . . . . .	294
Figure 98.	USART timing diagram in Slave mode . . . . .	294
Figure 99.	SPI timing diagram - slave mode and CPHA = 0 . . . . .	296
Figure 100.	SPI timing diagram - slave mode and CPHA = 1 <sup>(1)</sup> . . . . .	297

Figure 101. SPI timing diagram - master mode <sup>(1)</sup> . . . . .	297
Figure 102. I <sup>2</sup> S slave timing diagram (Philips protocol) <sup>(1)</sup> . . . . .	299
Figure 103. I <sup>2</sup> S master timing diagram (Philips protocol) <sup>(1)</sup> . . . . .	299
Figure 104. SAI master timing waveforms . . . . .	302
Figure 105. SAI slave timing waveforms . . . . .	302
Figure 106. MDIO Slave timing diagram . . . . .	303
Figure 107. SDIO high-speed mode . . . . .	305
Figure 108. SD default mode . . . . .	305
Figure 109. DDR mode . . . . .	305
Figure 110. ULPI timing diagram . . . . .	306
Figure 111. Ethernet SMI timing diagram . . . . .	307
Figure 112. Ethernet RMII timing diagram . . . . .	308
Figure 113. Ethernet MII timing diagram . . . . .	309
Figure 114. JTAG timing diagram . . . . .	310
Figure 115. SWD timing diagram . . . . .	310
Figure 116. LQFP100 package outline . . . . .	311
Figure 117. LQFP100 recommended footprint . . . . .	313
Figure 118. LQFP100 marking example (package top view) . . . . .	314
Figure 119. LQFP144 package outline . . . . .	315
Figure 120. LQFP144 package recommended footprint . . . . .	317
Figure 121. LQFP144 marking example (package top view) . . . . .	318
Figure 122. LQFP176 package outline . . . . .	319
Figure 123. LQFP176 package recommended footprint . . . . .	321
Figure 124. LQFP176 marking example (package top view) . . . . .	322
Figure 125. UFBGA176+25 package outline . . . . .	323
Figure 126. UFBGA176+25 package recommended footprint . . . . .	324
Figure 127. UFBGA176+25 marking example (package top view) . . . . .	325
Figure 128. TFBGA240+25 package outline . . . . .	326
Figure 129. TFBGA240+25 package recommended footprint . . . . .	327
Figure 130. TFBGA240+25 marking example (package top view) . . . . .	328

# 1 Introduction

This document provides information on STM32H750xB microcontrollers, such as description, functional overview, pin assignment and definition, electrical characteristics, packaging, and ordering information.

This document should be read in conjunction with the STM32H750xB reference manual (RM0433), available from the STMicroelectronics website [www.st.com](http://www.st.com).

For information on the Arm<sup>®(a)</sup> Cortex<sup>®</sup>-M7 core, please refer to the Cortex<sup>®</sup>-M7 Technical Reference Manual, available from the <http://www.arm.com> website.

The logo for Arm, consisting of the word "arm" in a bold, lowercase, sans-serif font.

---

a. Arm is a registered trademark of Arm Limited (or its subsidiaries) in the US and/or elsewhere.



## 2 Description

STM32H750xB devices are based on the high-performance Arm<sup>®</sup> Cortex<sup>®</sup>-M7 32-bit RISC core operating at up to 480 MHz. The Cortex<sup>®</sup>-M7 core features a floating point unit (FPU) which supports Arm<sup>®</sup> double-precision (IEEE 754 compliant) and single-precision data-processing instructions and data types. STM32H750xB devices support a full set of DSP instructions and a memory protection unit (MPU) to enhance application security.

STM32H750xB devices incorporate high-speed embedded memories with a Flash memory of 128 Kbytes, up to 1 Mbyte of RAM (including 192 Kbytes of TCM RAM, up to 864 Kbytes of user SRAM and 4 Kbytes of backup SRAM), as well as an extensive range of enhanced I/Os and peripherals connected to APB buses, AHB buses, 2x32-bit multi-AHB bus matrix and a multi layer AXI interconnect supporting internal and external memory access.

All the devices offer three ADCs, two DACs, two ultra-low power comparators, a low-power RTC, a high-resolution timer, 12 general-purpose 16-bit timers, two PWM timers for motor control, five low-power timers, a true random number generator (RNG), and a cryptographic acceleration cell. The devices support four digital filters for external sigma-delta modulators (DFSDM). They also feature standard and advanced communication interfaces.

- Standard peripherals
  - Four I<sup>2</sup>Cs
  - Four USARTs, four UARTs and one LPUART
  - Six SPIs, three I2Ss in Half-duplex mode. To achieve audio class accuracy, the I2S peripherals can be clocked by a dedicated internal audio PLL or by an external clock to allow synchronization.
  - Four SAI serial audio interfaces
  - One SPDIFRX interface
  - One SWPMI (Single Wire Protocol Master Interface)
  - Management Data Input/Output (MDIO) slaves
  - Two SDMMC interfaces
  - A USB OTG full-speed and a USB OTG high-speed interface with full-speed capability (with the ULPI)
  - One FDCAN plus one TT-FDCAN interface
  - An Ethernet interface
  - Chrom-ART Accelerator
  - HDMI-CEC
- Advanced peripherals including
  - A flexible memory control (FMC) interface
  - A Quad-SPI Flash memory interface
  - A camera interface for CMOS sensors
  - An LCD-TFT display controller
  - A JPEG hardware compressor/decompressor

Refer to [Table 1: STM32H750xB features and peripheral counts](#) for the list of peripherals available on each part number.

STM32H750xB devices operate in the  $-40$  to  $+85$  °C temperature range from a 1.62 to 3.6 V power supply. The supply voltage can drop down to 1.62 V by using an external power supervisor (see [Section 3.5.2: Power supply supervisor](#)) and connecting the PDR\_ON pin to  $V_{SS}$ . Otherwise the supply voltage must stay above 1.71 V with the embedded power voltage detector enabled.

Dedicated supply inputs for USB (OTG\_FS and OTG\_HS) are available on all packages except LQFP100 to allow a greater power supply choice.

A comprehensive set of power-saving modes allows the design of low-power applications.

STM32H750xB devices are offered in 3 packages ranging from 100 pins to 240 pins/balls. The set of included peripherals changes with the device chosen.

These features make STM32H750xB microcontrollers suitable for a wide range of applications:

- Motor drive and application control
- Medical equipment
- Industrial applications: PLC, inverters, circuit breakers
- Printers, and scanners
- Alarm systems, video intercom, and HVAC
- Home audio appliances
- Mobile applications, Internet of Things
- Wearable devices: smart watches.

[Figure 1](#) shows the device block diagram.

**Table 1. STM32H750xB features and peripheral counts**

Peripherals		STM32H750VB	STM32H750ZB	STM32H750IB	STM32H750XB
Flash memory in Kbytes		128			
SRAM in Kbytes	SRAM mapped onto AXI bus	512			
	SRAM1 (D2 domain)	128			
	SRAM2 (D2 domain)	128			
	SRAM3 (D2 domain)	32			
	SRAM4 (D3 domain)	64			
TCM RAM in Kbytes	ITCM RAM (instruction)	64			
	DTCM RAM (data)	128			
Backup SRAM (Kbytes)		4			
FMC		Yes			
General-purpose input/outputs		82	114	140	168
Quad-SPI interface		Yes			
Ethernet		Yes			

**Table 1. STM32H750xB features and peripheral counts (continued)**

Peripherals		STM32H750VB	STM32H750ZB	STM32H750IB	STM32H750XB
Timers	High-resolution	1			
	General-purpose	10			
	Advanced-control (PWM)	2			
	Basic	2			
	Low-power	5			
Wakeup pins		4		6	
Tamper pins		2		3	
Random number generator		Yes			
Cryptographic processor		Yes			
Communication interfaces	SPI / I2S	6/3 <sup>(1)</sup>			
	I2C	4			
	USART/UART/LPUART	4/4 /1			
	SAI	4			
	SPDIFRX	4 inputs			
	SWPMI	Yes			
	MDIO	Yes			
	SDMMC	2			
	FDCAN/TT-FDCAN	1/1			
	USB OTG_FS	Yes			
	USB OTG_HS	Yes			
Ethernet and camera interface		Yes			
LCD-TFT		Yes			
JPEG Codec		Yes			
Chrom-ART Accelerator (DMA2D)		Yes			
16-bit ADCs		3			
Number of Direct channels		2	2	2	4
Number of Fast channels		3	9	9	9
Number of Slow channels		11	17	21	23
12-bit DAC		Yes			
Number of channels		2			
Comparators		2			
Operational amplifiers		2			
DFSDM		Yes			
Maximum CPU frequency		480MHz <sup>(2)(3)</sup> /400 MHz			
Operating voltage		1.71 to 3.6 V <sup>(4)</sup>		1.62 to 3.6 V <sup>(5)</sup>	

Table 1. STM32H750xB features and peripheral counts (continued)

Peripherals	STM32H750VB	STM32H750ZB	STM32H750IB	STM32H750XB
Operating temperatures	Ambient temperatures: -40 up to +85 °C <sup>(6)</sup>			
	Junction temperature: -40 to + 125 °C			
Package	LQFP100	LQFP144	LQFP176, UFBGA176+25	TFBGA240+25

1. The SPI1, SPI2 and SPI3 interfaces give the flexibility to work in an exclusive way in either the SPI mode or the I2S audio mode.
2. The maximum CPU frequency of 480 MHz can be obtained on devices revision V.
3. The product junction temperature must be kept within the -40 to +105 °C temperature range.
4. Since the LQFP100 package does not feature the PDR\_ON pin (tied internally to V<sub>DD</sub>), the minimum V<sub>DD</sub> value for this package is 1.71 V.
5. V<sub>DD</sub>/V<sub>DDA</sub> can drop down to 1.62 V by using an external power supervisor (see [Section 3.5.2: Power supply supervisor](#)) and connecting PDR\_ON pin to V<sub>SS</sub>. Otherwise the supply voltage must stay above 1.71 V with the embedded power voltage detector enabled.
6. The product junction temperature must be kept within the -40 to +125 °C temperature range.

Figure 1. STM32H750xB block diagram

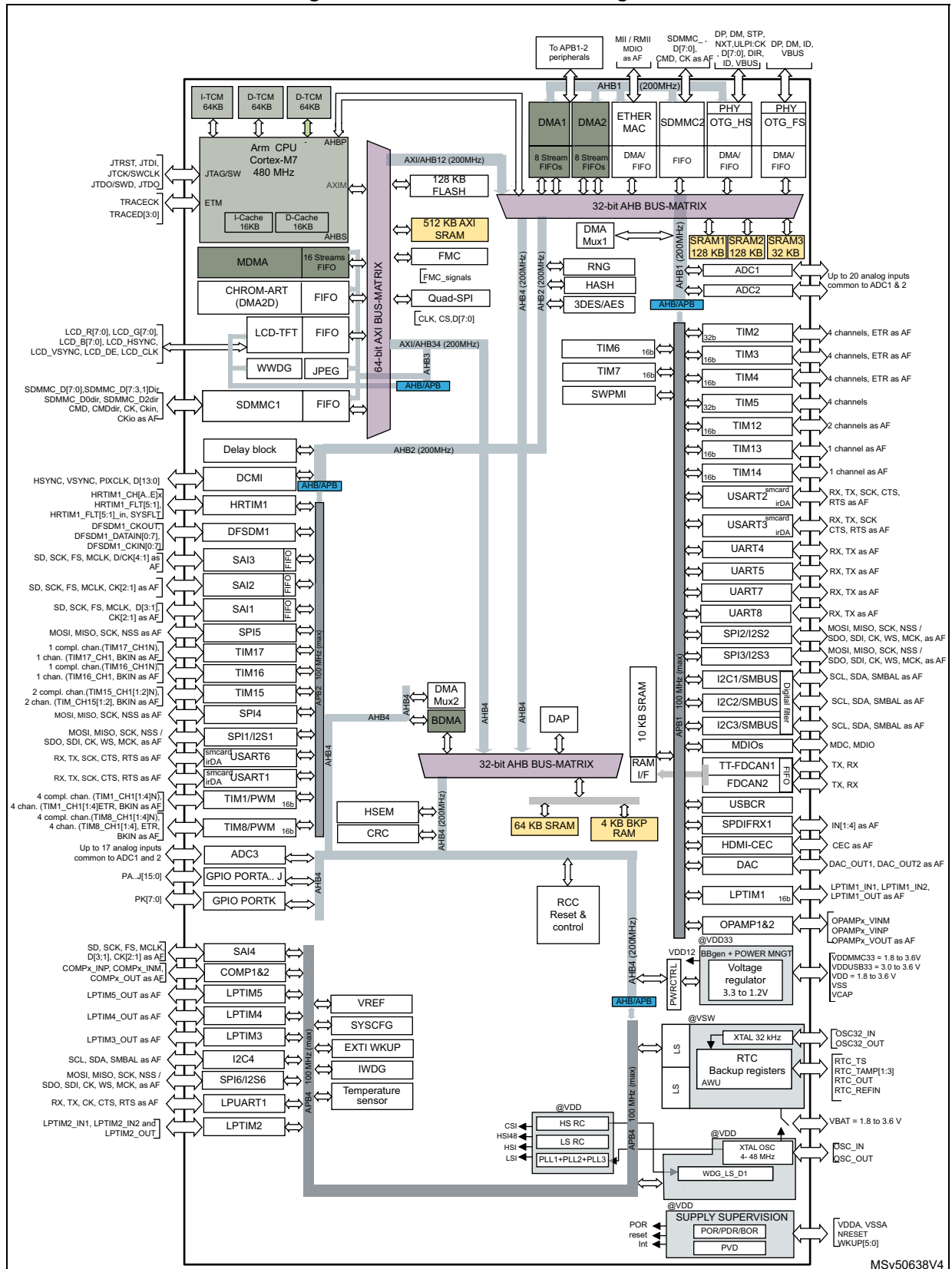

## 3 Functional overview

### 3.1 Arm<sup>®</sup> Cortex<sup>®</sup>-M7 with FPU

The Arm<sup>®</sup> Cortex<sup>®</sup>-M7 with double-precision FPU processor is the latest generation of Arm processors for embedded systems. It was developed to provide a low-cost platform that meets the needs of MCU implementation, with a reduced pin count and optimized power consumption, while delivering outstanding computational performance and low interrupt latency.

The Cortex<sup>®</sup>-M7 processor is a highly efficient high-performance featuring:

- Six-stage dual-issue pipeline
- Dynamic branch prediction
- Harvard architecture with L1 caches (16 Kbytes of I-cache and 16 Kbytes of D-cache)
- 64-bit AXI interface
- 64-bit ITCM interface
- 2x32-bit DTCM interfaces

The following memory interfaces are supported:

- Separate Instruction and Data buses (Harvard Architecture) to optimize CPU latency
- Tightly Coupled Memory (TCM) interface designed for fast and deterministic SRAM accesses
- AXI Bus interface to optimize Burst transfers
- Dedicated low-latency AHB-Lite peripheral bus (AHBP) to connect to peripherals.

The processor supports a set of DSP instructions which allow efficient signal processing and complex algorithm execution.

It also supports single and double precision FPU (floating point unit) speeds up software development by using metalanguage development tools, while avoiding saturation.

*Figure 1* shows the general block diagram of the STM32H750xB family.

*Note:* Cortex<sup>®</sup>-M7 with FPU core is binary compatible with the Cortex<sup>®</sup>-M4 core.

### 3.2 Memory protection unit (MPU)

The memory protection unit (MPU) manages the CPU access rights and the attributes of the system resources. It has to be programmed and enabled before use. Its main purposes are to prevent an untrusted user program to accidentally corrupt data used by the OS and/or by a privileged task, but also to protect data processes or read-protect memory regions.

The MPU defines access rules for privileged accesses and user program accesses. It allows defining up to 16 protected regions that can in turn be divided into up to 8 independent subregions, where region address, size, and attributes can be configured. The protection area ranges from 32 bytes to 4 Gbytes of addressable memory.

When an unauthorized access is performed, a memory management exception is generated.

## 3.3 Memories

### 3.3.1 Embedded Flash memory

The STM32H750xB devices embed 128 Kbytes of Flash memory that can be used for storing programs and data.

The Flash memory is organized as follows:

- 128 Kbytes of user Flash memory containing 128 Kbytes of System Flash memory from which the device can boot
- 2 Kbytes (64 Flash words) of user option bytes for user configuration

### 3.3.2 Secure access mode

In addition to other typical memory protection mechanism (RDP, PCROP), STM32H750xB devices introduce the Secure access mode, a new enhanced security feature. This mode allows developing user-defined secure services by ensuring, on the one hand code and data protection and on the other hand code safe execution.

Two types of secure services are available:

- STMicroelectronics Root Secure Services:  
These services are embedded in System memory. They provide a secure solution for firmware and third-party modules installation. These services rely on cryptographic algorithms based on a device unique private key.
- User-defined secure services:  
These services are embedded in user Flash memory. Examples of user secure services are proprietary user firmware update solution, secure Flash integrity check or any other sensitive applications that require a high level of protection.  
The secure firmware is embedded in specific user Flash memory areas configured through option bytes.

Secure services are executed just after a reset and preempt all other applications to guarantee protected and safe execution. Once executed, the corresponding code and data are no more accessible.

The above secure services are available only for Cortex<sup>®</sup>-M7 core operating in Secure access mode. The other masters cannot access the option bytes involved in Secure access mode settings or the Flash secured areas.

### 3.3.3 Embedded SRAM

All devices feature:

- 512 Kbytes of AXI-SRAM mapped onto AXI bus on D1 domain.
- SRAM1 mapped on D2 domain: 128 Kbytes
- SRAM2 mapped on D2 domain: 128 Kbytes
- SRAM3 mapped on D2 domain: 32 Kbytes
- SRAM4 mapped on D3 domain: 64 Kbytes
- 4 Kbytes of backup SRAM

The content of this area is protected against possible unwanted write accesses, and is retained in Standby or V<sub>BAT</sub> mode.

- RAM mapped to TCM interface (ITCM and DTCM):

Both ITCM and DTCM RAMs are 0 wait state memories. either They can be accessed either from the CPU or the MDMA (even in Sleep mode) through a specific AHB slave of the CPU(AHBP):

- 64 Kbytes of ITCM-RAM (instruction RAM)

This RAM is connected to ITCM 64-bit interface designed for execution of critical real-times routines by the CPU.

- 128 Kbytes of DTCM-RAM (2x 64-Kbyte DTCM-RAMs on 2x32-bit DTCM ports)

The DTCM-RAM could be used for critical real-time data, such as interrupt service routines or stack/heap memory. Both DTCM-RAMs can be used in parallel (for load/store operations) thanks to the Cortex<sup>®</sup>-M7 dual issue capability.

The MDMA can be used to load code or data in ITCM or DTCM RAMs.

#### Error code correction (ECC)

Over the product lifetime, and/or due to external events such as radiations, invalid bits in memories may occur. They can be detected and corrected by ECC. This is an expected behavior that has to be managed at final-application software level in order to ensure data integrity through ECC algorithms implementation.

SRAM data are protected by ECC:

- 7 ECC bits are added per 32-bit word.
- 8 ECC bits are added per 64-bit word for AXI-SRAM and ITCM-RAM.

The ECC mechanism is based on the SECDED algorithm. It supports single-error correction and double-error detection.

## 3.4 Boot modes

At startup, the boot memory space is selected by the BOOT pin and BOOT\_ADDx option bytes, allowing to program any boot memory address from 0x0000 0000 to 0x3FFF FFFF which includes:

- All Flash address space
- All RAM address space: ITCM, DTCM RAMs and SRAMs
- The System memory bootloader



The boot loader is located in non-user System memory. It is used to reprogram the Flash memory through a serial interface (USART, I2C, SPI, USB-DFU). Refer to *STM32 microcontroller System memory Boot mode* application note (AN2606) for details.

## 3.5 Power supply management

### 3.5.1 Power supply scheme

STM32H750xB power supply voltages are the following:

- $V_{DD} = 1.62$  to  $3.6$  V: external power supply for I/Os, provided externally through  $V_{DD}$  pins.
- $V_{DDLDO} = 1.62$  to  $3.6$  V: supply voltage for the internal regulator supplying  $V_{CORE}$
- $V_{DDA} = 1.62$  to  $3.6$  V: external analog power supplies for ADC, DAC, COMP and OPAMP.
- $V_{DD33USB}$  and  $V_{DD50USB}$ :  
 $V_{DD50USB}$  can be supplied through the USB cable to generate the  $V_{DD33USB}$  via the USB internal regulator. This allows supporting a  $V_{DD}$  supply different from  $3.3$  V.  
The USB regulator can be bypassed to supply directly  $V_{DD33USB}$  if  $V_{DD} = 3.3$  V.
- $V_{BAT} = 1.2$  to  $3.6$  V: power supply for the  $V_{SW}$  domain when  $V_{DD}$  is not present.
- $V_{CAP}$ :  $V_{CORE}$  supply voltage, which values depend on voltage scaling ( $1.0$  V,  $1.1$  V,  $1.2$  V or  $1.35$  V). They are configured through VOS bits in PWR\_D3CR register and ODEN bit in the SYSCFG\_PWRCR register. The  $V_{CORE}$  domain is split into the following power domains that can be independently switch off.
  - D1 domain containing some peripherals and the Cortex<sup>®</sup>-M7 core.
  - D2 domain containing a large part of the peripherals.
  - D3 domain containing some peripherals and the system control.

During power-up and power-down phases, the following power sequence requirements must be respected (see [Figure 2](#)):

- When  $V_{DD}$  is below  $1$  V, other power supplies ( $V_{DDA}$ ,  $V_{DD33USB}$ ,  $V_{DD50USB}$ ) must remain below  $V_{DD} + 300$  mV.
- When  $V_{DD}$  is above  $1$  V, all power supplies are independent.

During the power-down phase,  $V_{DD}$  can temporarily become lower than other supplies only if the energy provided to the microcontroller remains below  $1$  mJ. This allows external decoupling capacitors to be discharged with different time constants during the power-down transient phase.

Figure 2. Power-up/power-down sequence

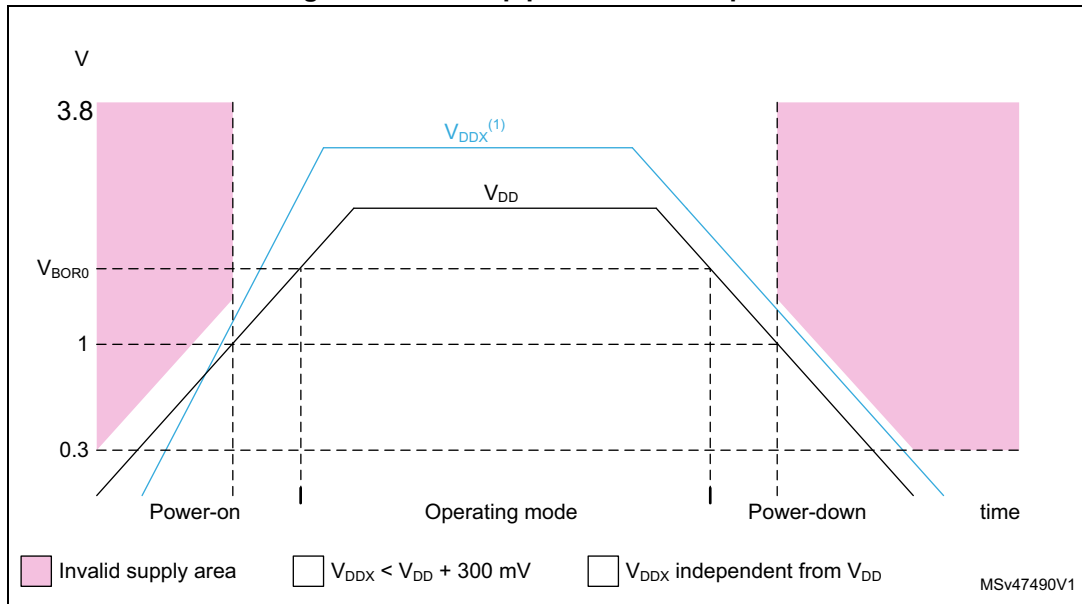

1.  $V_{DDx}$  refers to any power supply among  $V_{DDA}$ ,  $V_{DD33USB}$ ,  $V_{DD50USB}$ .

### 3.5.2 Power supply supervisor

The devices have an integrated power-on reset (POR)/ power-down reset (PDR) circuitry coupled with a Brownout reset (BOR) circuitry:

- Power-on reset (POR)
 

The POR supervisor monitors  $V_{DD}$  power supply and compares it to a fixed threshold. The devices remain in Reset mode when  $V_{DD}$  is below this threshold,
- Power-down reset (PDR)
 

The PDR supervisor monitors  $V_{DD}$  power supply. A reset is generated when  $V_{DD}$  drops below a fixed threshold.

The PDR supervisor can be enabled/disabled through PDR\_ON pin.
- Brownout reset (BOR)
 

The BOR supervisor monitors  $V_{DD}$  power supply. Three BOR thresholds (from 2.1 to 2.7 V) can be configured through option bytes. A reset is generated when  $V_{DD}$  drops below this threshold.

### 3.5.3 Voltage regulator

The same voltage regulator supplies the 3 power domains (D1, D2 and D3). D1 and D2 can be independently switched off.

Voltage regulator output can be adjusted according to application needs through 6 power supply levels:

- Run mode (VOS0 to VOS3)
  - Scale 0: boosted performance (available only with LDO regulator)
  - Scale 1: high performance
  - Scale 2: medium performance and consumption
  - Scale 3: optimized performance and low-power consumption
- Stop mode (SVOS3 to SVOS5)
  - Scale 3: peripheral with wakeup from Stop mode capabilities (UART, SPI, I2C, LPTIM) are operational
  - Scale 4 and 5 where the peripheral with wakeup from Stop mode is disabled  
The peripheral functionality is disabled but wakeup from Stop mode is possible through GPIO or asynchronous interrupt.

## 3.6 Low-power strategy

There are several ways to reduce power consumption on STM32H750xB:

- Decrease the dynamic power consumption by slowing down the system clocks even in Run mode and by individually clock gating the peripherals that are not used.
- Save power consumption when the CPU is idle, by selecting among the available low-power mode according to the user application needs. This allows achieving the best compromise between short startup time, low-power consumption, as well as available wakeup sources.

The devices feature several low-power modes:

- CSleep (CPU clock stopped)
- CStop (CPU sub-system clock stopped)
- DStop (Domain bus matrix clock stopped)
- Stop (System clock stopped)
- DStandby (Domain powered down)
- Standby (System powered down)

CSleep and CStop low-power modes are entered by the MCU when executing the WFI (Wait for Interrupt) or WFE (Wait for Event) instructions, or when the SLEEPONEXIT bit of the Cortex<sup>®</sup>-Mx core is set after returning from an interrupt service routine.

A domain can enter low-power mode (DStop or DStandby) when the processor, its subsystem and the peripherals allocated in the domain enter low-power mode.

If part of the domain is not in low-power mode, the domain remains in the current mode.

Finally the system can enter Stop or Standby when all EXTI wakeup sources are cleared and the power domains are in DStop or DStandby mode.

Table 2. System vs domain low-power mode

System power mode	D1 domain power mode	D2 domain power mode	D3 domain power mode
Run	DRun/DStop/DStandby	DRun/DStop/DStandby	DRun
Stop	DStop/DStandby	DStop/DStandby	DStop
Standby	DStandby	DStandby	DStandby

## 3.7 Reset and clock controller (RCC)

The clock and reset controller is located in D3 domain. The RCC manages the generation of all the clocks, as well as the clock gating and the control of the system and peripheral resets. It provides a high flexibility in the choice of clock sources and allows to apply clock ratios to improve the power consumption. In addition, on some communication peripherals that are capable to work with two different clock domains (either a bus interface clock or a kernel peripheral clock), the system frequency can be changed without modifying the baudrate.

### 3.7.1 Clock management

The devices embed four internal oscillators, two oscillators with external crystal or resonator, two internal oscillators with fast startup time and three PLLs.

The RCC receives the following clock source inputs:

- Internal oscillators:
  - 64 MHz HSI clock
  - 48 MHz RC oscillator
  - 4 MHz CSI clock
  - 32 kHz LSI clock
- External oscillators:
  - HSE clock: 4-50 MHz (generated from an external source) or 4-48 MHz (generated from a crystal/ceramic resonator)
  - LSE clock: 32.768 kHz

The RCC provides three PLLs: one for system clock, two for kernel clocks.

The system starts on the HSI clock. The user application can then select the clock configuration.

### 3.7.2 System reset sources

Power-on reset initializes all registers while system reset reinitializes the system except for the debug, part of the RCC and power controller status registers, as well as the backup power domain.

A system reset is generated in the following cases:

- Power-on reset (pwr\_por\_rst)
- Brownout reset
- Low level on NRST pin (external reset)
- Window watchdog
- Independent watchdog
- Software reset
- Low-power mode security reset
- Exit from Standby

### 3.8 General-purpose input/outputs (GPIOs)

Each of the GPIO pins can be configured by software as output (push-pull or open-drain, with or without pull-up or pull-down), as input (floating, with or without pull-up or pull-down) or as peripheral alternate function. Most of the GPIO pins are shared with digital or analog alternate functions. All GPIOs are high-current-capable and have speed selection to better manage internal noise, power consumption and electromagnetic emission.

After reset, all GPIOs (except debug pins) are in Analog mode to reduce power consumption (refer to GPIOs register reset values in the device reference manual).

The I/O configuration can be locked if needed by following a specific sequence in order to avoid spurious writing to the I/Os registers.

### 3.9 Bus-interconnect matrix

The devices feature an AXI bus matrix, two AHB bus matrices and bus bridges that allow interconnecting bus masters with bus slaves (see [Figure 3](#)).



Figure 3. STM32H750xB bus matrix

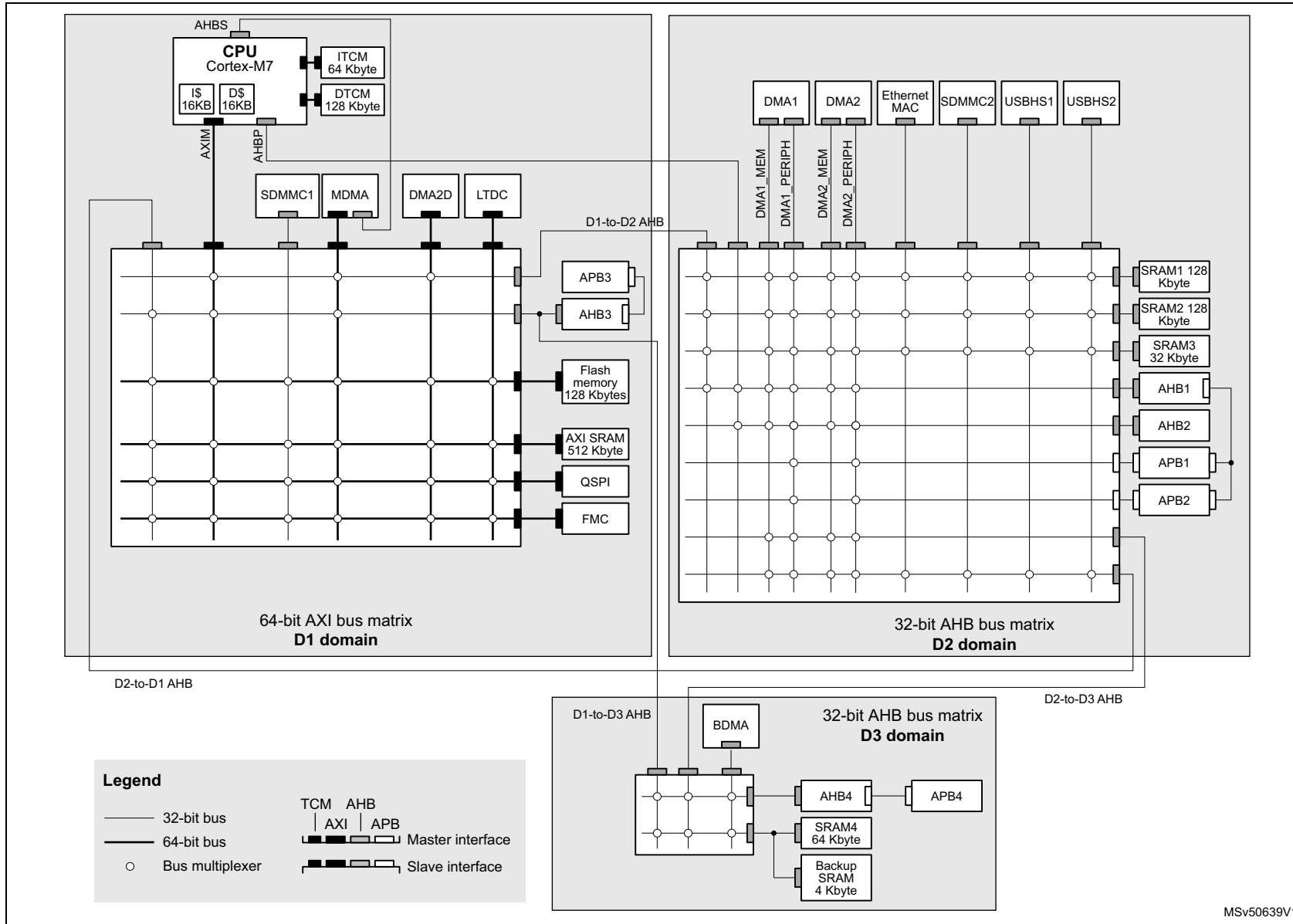

MSv50639V1

### 3.10 DMA controllers

The devices feature four DMA instances to unload CPU activity:

- A master direct memory access (MDMA)  
The MDMA is a high-speed DMA controller, which is in charge of all types of memory transfers (peripheral to memory, memory to memory, memory to peripheral), without any CPU action. It features a master AXI interface and a dedicated AHB interface to access Cortex<sup>®</sup>-M7 TCM memories.  
The MDMA is located in D1 domain. It is able to interface with the other DMA controllers located in D2 domain to extend the standard DMA capabilities, or can manage peripheral DMA requests directly.  
Each of the 16 channels can perform single block transfers, repeated block transfers and linked list transfers.
- Two dual-port DMAs (DMA1, DMA2) located in D2 domain, with FIFO and request router capabilities.
- One basic DMA (BDMA) located in D3 domain, with request router capabilities.

The DMA request router could be considered as an extension of the DMA controller. It routes the DMA peripheral requests to the DMA controller itself. This allowing managing the DMA requests with a high flexibility, maximizing the number of DMA requests that run concurrently, as well as generating DMA requests from peripheral output trigger or DMA event.

### 3.11 Chrom-ART Accelerator (DMA2D)

The Chrom-Art Accelerator (DMA2D) is a graphical accelerator which offers advanced bit blitting, row data copy and pixel format conversion. It supports the following functions:

- Rectangle filling with a fixed color
- Rectangle copy
- Rectangle copy with pixel format conversion
- Rectangle composition with blending and pixel format conversion

Various image format coding are supported, from indirect 4bpp color mode up to 32bpp direct color. It embeds dedicated memory to store color lookup tables. The DMA2D also supports block based YCbCr to handle JPEG decoder output.

An interrupt can be generated when an operation is complete or at a programmed watermark.

All the operations are fully automatized and are running independently from the CPU or the DMAs.

### 3.12 Nested vectored interrupt controller (NVIC)

The devices embed a nested vectored interrupt controller which is able to manage 16 priority levels, and handle up to 150 maskable interrupt channels plus the 16 interrupt lines of the Cortex<sup>®</sup>-M7 with FPU core.

- Closely coupled NVIC gives low-latency interrupt processing
- Interrupt entry vector table address passed directly to the core
- Allows early processing of interrupts
- Processing of late arriving, higher-priority interrupts
- Support tail chaining
- Processor context automatically saved on interrupt entry, and restored on interrupt exit with no instruction overhead

This hardware block provides flexible interrupt management features with minimum interrupt latency.

### 3.13 Extended interrupt and event controller (EXTI)

The EXTI controller performs interrupt and event management. In addition, it can wake up the processor, power domains and/or D3 domain from Stop mode.

The EXTI handles up to 89 independent event/interrupt lines split as 28 configurable events and 61 direct events .

Configurable events have dedicated pending flags, active edge selection, and software trigger capable.

Direct events provide interrupts or events from peripherals having a status flag.

### 3.14 Cyclic redundancy check calculation unit (CRC)

The CRC (cyclic redundancy check) calculation unit is used to get a CRC code using a programmable polynomial.

Among other applications, CRC-based techniques are used to verify data transmission or storage integrity. In the scope of the EN/IEC 60335-1 standard, they offer a means of verifying the Flash memory integrity. The CRC calculation unit helps compute a signature of the software during runtime, to be compared with a reference signature generated at link-time and stored at a given memory location.



### 3.15 Flexible memory controller (FMC)

The FMC controller main features are the following:

- Interface with static-memory mapped devices including:
  - Static random access memory (SRAM)
  - NOR Flash memory/OneNAND Flash memory
  - PSRAM (4 memory banks)
  - NAND Flash memory with ECC hardware to check up to 8 Kbytes of data
- Interface with synchronous DRAM (SDRAM/Mobile LPDDR SDRAM) memories
- 8-,16-,32-bit data bus width
- Independent Chip Select control for each memory bank
- Independent configuration for each memory bank
- Write FIFO
- Read FIFO for SDRAM controller
- The maximum FMC\_CLK/FMC\_SDCLK frequency for synchronous accesses is the FMC kernel clock divided by 2.

### 3.16 Quad-SPI memory interface (QUADSPI)

All devices embed a Quad-SPI memory interface, which is a specialized communication interface targeting Single, Dual or Quad-SPI Flash memories. It supports both single and double datarate operations.

It can operate in any of the following modes:

- Direct mode through registers
- External Flash status register polling mode
- Memory mapped mode.

Up to 256 Mbytes of external Flash memory can be mapped, and 8-, 16- and 32-bit data accesses are supported as well as code execution.

The opcode and the frame format are fully programmable.

### 3.17 Analog-to-digital converters (ADCs)

The STM32H750xB devices embed three analog-to-digital converters, which resolution can be configured to 16, 14, 12, 10 or 8 bits.

Each ADC shares up to 20 external channels, performing conversions in the Single-shot or Scan mode. In Scan mode, automatic conversion is performed on a selected group of analog inputs.

Additional logic functions embedded in the ADC interface allow:

- Simultaneous sample and hold
- Interleaved sample and hold

The ADC can be served by the DMA controller, thus allowing to automatically transfer ADC converted values to a destination location without any software action.

In addition, an analog watchdog feature can accurately monitor the converted voltage of one, some or all selected channels. An interrupt is generated when the converted voltage is outside the programmed thresholds.

To synchronize A/D conversion and timers, the ADCs could be triggered by any of TIM1, TIM2, TIM3, TIM4, TIM6, TIM8, TIM15, HRTIM1 and LPTIM1 timer.

### 3.18 Temperature sensor

STM32H750xB devices embed a temperature sensor that generates a voltage ( $V_{TS}$ ) that varies linearly with the temperature. This temperature sensor is internally connected to ADC3\_IN18. The conversion range is between 1.7 V and 3.6 V. It can measure the device junction temperature ranging from  $\approx 40$  up to  $+125$  °C.

The temperature sensor have a good linearity, but it has to be calibrated to obtain a good overall accuracy of the temperature measurement. As the temperature sensor offset varies from chip to chip due to process variation, the uncalibrated internal temperature sensor is suitable for applications that detect temperature changes only. To improve the accuracy of the temperature sensor measurement, each device is individually factory-calibrated by ST. The temperature sensor factory calibration data are stored by ST in the System memory area, which is accessible in Read-only mode.

### 3.19 $V_{BAT}$ operation

The  $V_{BAT}$  power domain contains the RTC, the backup registers and the backup SRAM.

To optimize battery duration, this power domain is supplied by  $V_{DD}$  when available or by the voltage applied on VBAT pin (when  $V_{DD}$  supply is not present).  $V_{BAT}$  power is switched when the PDR detects that  $V_{DD}$  dropped below the PDR level.

The voltage on the VBAT pin could be provided by an external battery, a supercapacitor or directly by  $V_{DD}$ , in which case, the  $V_{BAT}$  mode is not functional.

$V_{BAT}$  operation is activated when  $V_{DD}$  is not present.

The  $V_{BAT}$  pin supplies the RTC, the backup registers and the backup SRAM.

*Note:* When the microcontroller is supplied from  $V_{BAT}$ , external interrupts and RTC alarm/events do not exit it from  $V_{BAT}$  operation.

*When PDR\_ON pin is connected to  $V_{SS}$  (Internal Reset OFF), the  $V_{BAT}$  functionality is no more available and  $V_{BAT}$  pin should be connected to  $V_{DD}$ .*

### 3.20 Digital-to-analog converters (DAC)

The two 12-bit buffered DAC channels can be used to convert two digital signals into two analog voltage signal outputs.

This dual digital Interface supports the following features:

- two DAC converters: one for each output channel
- 8-bit or 12-bit monotonic output
- left or right data alignment in 12-bit mode
- synchronized update capability
- noise-wave generation
- triangular-wave generation
- dual DAC channel independent or simultaneous conversions
- DMA capability for each channel including DMA underrun error detection
- external triggers for conversion
- input voltage reference  $V_{REF+}$  or internal VREFBUF reference.

The DAC channels are triggered through the timer update outputs that are also connected to different DMA streams.

### 3.21 Ultra-low-power comparators (COMP)

STM32H750xB devices embed two rail-to-rail comparators (COMP1 and COMP2). They feature programmable reference voltage (internal or external), hysteresis and speed (low speed for low-power) as well as selectable output polarity.

The reference voltage can be one of the following:

- An external I/O
- A DAC output channel
- An internal reference voltage or submultiple (1/4, 1/2, 3/4).

All comparators can wake up from Stop mode, generate interrupts and breaks for the timers, and be combined into a window comparator.

### 3.22 Operational amplifiers (OPAMP)

STM32H750xB devices embed two rail-to-rail operational amplifiers (OPAMP1 and OPAMP2) with external or internal follower routing and PGA capability.

The operational amplifier main features are:

- PGA with a non-inverting gain ranging of 2, 4, 8 or 16 or inverting gain ranging of -1, -3, -7 or -15
- One positive input connected to DAC
- Output connected to internal ADC
- Low input bias current down to 1 nA
- Low input offset voltage down to 1.5 mV
- Gain bandwidth up to 7.3 MHz

The devices embeds two operational amplifiers (OPAMP1 and OPAMP2) with two inputs and one output each. These three I/Os can be connected to the external pins, thus enabling any type of external interconnections. The operational amplifiers can be configured internally as a follower, as an amplifier with a non-inverting gain ranging from 2 to 16 or with inverting gain ranging from -1 to -15.

### 3.23 Digital filter for sigma-delta modulators (DFSDM)

The devices embed one DFSDM with 4 digital filters modules and 8 external input serial channels (transceivers) or alternately 8 internal parallel inputs support.

The DFSDM peripheral is dedicated to interface the external  $\Sigma\Delta$  modulators to microcontroller and then to perform digital filtering of the received data streams (which represent analog value on  $\Sigma\Delta$  modulators inputs). DFSDM can also interface PDM (Pulse Density Modulation) microphones and perform PDM to PCM conversion and filtering in hardware. DFSDM features optional parallel data stream inputs from internal ADC peripherals or microcontroller memory (through DMA/CPU transfers into DFSDM).

DFSDM transceivers support several serial interface formats (to support various  $\Sigma\Delta$  modulators). DFSDM digital filter modules perform digital processing according user selected filter parameters with up to 24-bit final ADC resolution.

The DFSDM peripheral supports:

- 8 multiplexed input digital serial channels:
  - configurable SPI interface to connect various SD modulator(s)
  - configurable Manchester coded 1 wire interface support
  - PDM (Pulse Density Modulation) microphone input support
  - maximum input clock frequency up to 20 MHz (10 MHz for Manchester coding)
  - clock output for SD modulator(s): 0..20 MHz
- alternative inputs from 8 internal digital parallel channels (up to 16 bit input resolution):
  - internal sources: ADC data or memory data streams (DMA)
- 4 digital filter modules with adjustable digital signal processing:
  - Sinc<sup>x</sup> filter: filter order/type (1..5), oversampling ratio (up to 1..1024)
  - integrator: oversampling ratio (1..256)
- up to 24-bit output data resolution, signed output data format
- automatic data offset correction (offset stored in register by user)
- continuous or single conversion
- start-of-conversion triggered by:
  - software trigger
  - internal timers
  - external events
  - start-of-conversion synchronously with first digital filter module (DFSDM0)
- analog watchdog feature:
  - low value and high value data threshold registers
  - dedicated configurable Sinc<sup>x</sup> digital filter (order = 1..3, oversampling ratio = 1..32)
  - input from final output data or from selected input digital serial channels
  - continuous monitoring independently from standard conversion

- short circuit detector to detect saturated analog input values (bottom and top range):
  - up to 8-bit counter to detect 1..256 consecutive 0's or 1's on serial data stream
  - monitoring continuously each input serial channel
- break signal generation on analog watchdog event or on short circuit detector event
- extremes detector:
  - storage of minimum and maximum values of final conversion data
  - refreshed by software
- DMA capability to read the final conversion data
- interrupts: end of conversion, overrun, analog watchdog, short circuit, input serial channel clock absence
- “regular” or “injected” conversions:
  - “regular” conversions can be requested at any time or even in Continuous mode without having any impact on the timing of “injected” conversions
  - “injected” conversions for precise timing and with high conversion priority

**Table 3. DFSDM implementation**

DFSDM features	DFSDM1
Number of filters	4
Number of input transceivers/channels	8
Internal ADC parallel input	X
Number of external triggers	16
Regular channel information in identification register	X

### 3.24 Digital camera interface (DCMI)

The devices embed a camera interface that can connect with camera modules and CMOS sensors through an 8-bit to 14-bit parallel interface, to receive video data. The camera interface can achieve a data transfer rate up to 140 Mbyte/s using a 80 MHz pixel clock. It features:

- Programmable polarity for the input pixel clock and synchronization signals
- Parallel data communication can be 8-, 10-, 12- or 14-bit
- Supports 8-bit progressive video monochrome or raw bayer format, YCbCr 4:2:2 progressive video, RGB 565 progressive video or compressed data (like JPEG)
- Supports Continuous mode or Snapshot (a single frame) mode
- Capability to automatically crop the image

### 3.25 LCD-TFT controller

The LCD-TFT display controller provides a 24-bit parallel digital RGB (Red, Green, Blue) and delivers all signals to interface directly to a broad range of LCD and TFT panels up to XGA (1024x768) resolution with the following features:

- 2 display layers with dedicated FIFO (64x64-bit)
- Color Look-Up table (CLUT) up to 256 colors (256x24-bit) per layer
- Up to 8 input color formats selectable per layer
- Flexible blending between two layers using alpha value (per pixel or constant)
- Flexible programmable parameters for each layer
- Color keying (transparency color)
- Up to 4 programmable interrupt events
- AXI master interface with burst of 16 words

### 3.26 JPEG Codec (JPEG)

The JPEG Codec can encode and decode a JPEG stream as defined in the *ISO/IEC 10918-1* specification. It provides an fast and simple hardware compressor and decompressor of JPEG images with full management of JPEG headers.

The JPEG codec main features are as follows:

- 8-bit/channel pixel depths
- Single clock per pixel encoding and decoding
- Support for JPEG header generation and parsing
- Up to four programmable quantization tables
- Fully programmable Huffman tables (two AC and two DC)
- Fully programmable minimum coded unit (MCU)
- Encode/decode support (non simultaneous)
- Single clock Huffman coding and decoding
- Two-channel interface: Pixel/Compress In, Pixel/Compressed Out
- Support for single greyscale component
- Ability to enable/disable header processing
- Fully synchronous design
- Configuration for High-speed decode mode

### 3.27 Random number generator (RNG)

All devices embed an RNG that delivers 32-bit random numbers generated by an integrated analog circuit.

### 3.28 Cryptographic acceleration (CRYP and HASH)

The devices embed a cryptographic processor that supports the advanced cryptographic algorithms usually required to ensure confidentiality, authentication, data integrity and non-repudiation when exchanging messages with a peer:

- Encryption/Decryption
  - DES/TDES (data encryption standard/triple data encryption standard): ECB (electronic codebook) and CBC (cipher block chaining) chaining algorithms, 64-, 128- or 192-bit key
  - AES (advanced encryption standard): ECB, CBC, GCM, CCM, and CTR (Counter mode) chaining algorithms, 128, 192 or 256-bit key
- Universal HASH
  - SHA-1 and SHA-2 (secure HASH algorithms)
  - MD5
  - HMAC

The cryptographic accelerator supports DMA request generation.

### 3.29 Timers and watchdogs

The devices include one high-resolution timer, two advanced-control timers, ten general-purpose timers, two basic timers, five low-power timers, two watchdogs and a SysTick timer.

All timer counters can be frozen in Debug mode.

[Table 4](#) compares the features of the advanced-control, general-purpose and basic timers.

**Table 4. Timer feature comparison**

Timer type	Timer	Counter resolution	Counter type	Prescaler factor	DMA request generation	Capture/compare channels	Complementary output	Max interface clock (MHz)	Max timer clock (MHz) <sup>(1)</sup>
High-resolution timer	HRTIM1	16-bit	Up	/1 /2 /4 (x2 x4 x8 x16 x32, with DLL)	Yes	10	Yes	480	480
Advanced-control	TIM1, TIM8	16-bit	Up, Down, Up/down	Any integer between 1 and 65536	Yes	4	Yes	120	240

Table 4. Timer feature comparison (continued)

Timer type	Timer	Counter resolution	Counter type	Prescaler factor	DMA request generation	Capture/compare channels	Complementary output	Max interface clock (MHz)	Max timer clock (MHz) <sup>(1)</sup>
General purpose	TIM2, TIM5	32-bit	Up, Down, Up/down	Any integer between 1 and 65536	Yes	4	No	120	240
	TIM3, TIM4	16-bit	Up, Down, Up/down	Any integer between 1 and 65536	Yes	4	No	120	240
	TIM12	16-bit	Up	Any integer between 1 and 65536	No	2	No	120	240
	TIM13, TIM14	16-bit	Up	Any integer between 1 and 65536	No	1	No	120	240
	TIM15	16-bit	Up	Any integer between 1 and 65536	Yes	2	1	120	240
	TIM16, TIM17	16-bit	Up	Any integer between 1 and 65536	Yes	1	1	120	240
Basic	TIM6, TIM7	16-bit	Up	Any integer between 1 and 65536	Yes	0	No	120	240
Low-power timer	LPTIM1, LPTIM2, LPTIM3, LPTIM4, LPTIM5	16-bit	Up	1, 2, 4, 8, 16, 32, 64, 128	No	0	No	120	240

1. The maximum timer clock is up to 480 MHz depending on TIMPRE bit in the RCC\_CFGR register and D2PRE1/2 bits in RCC\_D2CFGR register.



### 3.29.1 High-resolution timer (HRTIM1)

The high-resolution timer (HRTIM1) allows generating digital signals with high-accuracy timings, such as PWM or phase-shifted pulses.

It consists of 6 timers, 1 master and 5 slaves, totaling 10 high-resolution outputs, which can be coupled by pairs for deadtime insertion. It also features 5 fault inputs for protection purposes and 10 inputs to handle external events such as current limitation, zero voltage or zero current switching.

The HRTIM1 timer is made of a digital kernel clocked at 480 MHz. The high-resolution is available on the 10 outputs in all operating modes: variable duty cycle, variable frequency, and constant ON time.

The slave timers can be combined to control multistage complex converters or operate independently to manage multiple independent converters.

The waveforms are defined by a combination of user-defined timings and external events such as analog or digital feedback signals.

HRTIM1 timer includes options for blanking and filtering out spurious events or faults. It also offers specific modes and features to offload the CPU: DMA requests, Burst mode controller, Push-pull and Resonant mode.

It supports many topologies including LLC, Full bridge phase shifted, buck or boost converters, either in voltage or current mode, as well as lighting application (fluorescent or LED). It can also be used as a general purpose timer, for instance to achieve high-resolution PWM-emulated DAC.

### 3.29.2 Advanced-control timers (TIM1, TIM8)

The advanced-control timers (TIM1, TIM8) can be seen as three-phase PWM generators multiplexed on 6 channels. They have complementary PWM outputs with programmable inserted dead times. They can also be considered as complete general-purpose timers. Their 4 independent channels can be used for:

- Input capture
- Output compare
- PWM generation (Edge- or Center-aligned modes)
- One-pulse mode output

If configured as standard 16-bit timers, they have the same features as the general-purpose TIMx timers. If configured as 16-bit PWM generators, they have full modulation capability (0-100%).

The advanced-control timer can work together with the TIMx timers via the Timer Link feature for synchronization or event chaining.

TIM1 and TIM8 support independent DMA request generation.

### 3.29.3 General-purpose timers (TIMx)

There are ten synchronizable general-purpose timers embedded in the STM32H750xB devices (see [Table 4](#) for differences).

- **TIM2, TIM3, TIM4, TIM5**

The devices include 4 full-featured general-purpose timers: TIM2, TIM3, TIM4 and TIM5. TIM2 and TIM5 are based on a 32-bit auto-reload up/downcounter and a 16-bit prescaler while TIM3 and TIM4 are based on a 16-bit auto-reload up/downcounter and a 16-bit prescaler. All timers feature 4 independent channels for input capture/output compare, PWM or One-pulse mode output. This gives up to 16 input capture/output compare/PWMs on the largest packages.

TIM2, TIM3, TIM4 and TIM5 general-purpose timers can work together, or with the other general-purpose timers and the advanced-control timers TIM1 and TIM8 via the Timer Link feature for synchronization or event chaining.

Any of these general-purpose timers can be used to generate PWM outputs.

TIM2, TIM3, TIM4, TIM5 all have independent DMA request generation. They are capable of handling quadrature (incremental) encoder signals and the digital outputs from 1 to 4 hall-effect sensors.

- **TIM12, TIM13, TIM14, TIM15, TIM16, TIM17**

These timers are based on a 16-bit auto-reload upcounter and a 16-bit prescaler. TIM13, TIM14, TIM16 and TIM17 feature one independent channel, whereas TIM12 and TIM15 have two independent channels for input capture/output compare, PWM or One-pulse mode output. They can be synchronized with the TIM2, TIM3, TIM4, TIM5 full-featured general-purpose timers or used as simple timebases.

### 3.29.4 Basic timers TIM6 and TIM7

These timers are mainly used for DAC trigger and waveform generation. They can also be used as a generic 16-bit time base.

TIM6 and TIM7 support independent DMA request generation.

### 3.29.5 Low-power timers (LPTIM1, LPTIM2, LPTIM3, LPTIM4, LPTIM5)

The low-power timers have an independent clock and is running also in Stop mode if it is clocked by LSE, LSI or an external clock. It is able to wakeup the devices from Stop mode.

This low-power timer supports the following features:

- 16-bit up counter with 16-bit autoreload register
- 16-bit compare register
- Configurable output: pulse, PWM
- Continuous / One-shot mode
- Selectable software / hardware input trigger
- Selectable clock source:
  - Internal clock source: LSE, LSI, HSI or APB clock
  - External clock source over LPTIM input (working even with no internal clock source running, used by the Pulse Counter Application)
- Programmable digital glitch filter
- Encoder mode

### 3.29.6 Independent watchdog

The independent watchdog is based on a 12-bit downcounter and 8-bit prescaler. It is clocked from an independent 32 kHz internal RC and as it operates independently from the main clock, it can operate in Stop and Standby modes. It can be used either as a watchdog to reset the device when a problem occurs, or as a free-running timer for application timeout management. It is hardware- or software-configurable through the option bytes.

### 3.29.7 Window watchdog

The window watchdog is based on a 7-bit downcounter that can be set as free-running. It can be used as a watchdog to reset the device when a problem occurs. It is clocked from the main clock. It has an early warning interrupt capability and the counter can be frozen in Debug mode.

### 3.29.8 SysTick timer

This timer is dedicated to real-time operating systems, but could also be used as a standard downcounter. It features:

- A 24-bit downcounter
- Autoreload capability
- Maskable system interrupt generation when the counter reaches 0
- Programmable clock source.

### 3.30 Real-time clock (RTC), backup SRAM and backup registers

The RTC is an independent BCD timer/counter. It supports the following features:

- Calendar with subsecond, seconds, minutes, hours (12 or 24 format), week day, date, month, year, in BCD (binary-coded decimal) format.
- Automatic correction for 28, 29 (leap year), 30, and 31 days of the month.
- Two programmable alarms.
- On-the-fly correction from 1 to 32767 RTC clock pulses. This can be used to synchronize it with a master clock.
- Reference clock detection: a more precise second source clock (50 or 60 Hz) can be used to enhance the calendar precision.
- Digital calibration circuit with 0.95 ppm resolution, to compensate for quartz crystal inaccuracy.
- Three anti-tamper detection pins with programmable filter.
- Timestamp feature which can be used to save the calendar content. This function can be triggered by an event on the timestamp pin, or by a tamper event, or by a switch to  $V_{BAT}$  mode.
- 17-bit auto-reload wakeup timer (WUT) for periodic events with programmable resolution and period.

The RTC and the 32 backup registers are supplied through a switch that takes power either from the  $V_{DD}$  supply when present or from the  $V_{BAT}$  pin.

The backup registers are 32-bit registers used to store 128 bytes of user application data when  $V_{DD}$  power is not present. They are not reset by a system or power reset, or when the device wakes up from Standby mode.

The RTC clock sources can be:

- A 32.768 kHz external crystal (LSE)
- An external resonator or oscillator (LSE)
- The internal low-power RC oscillator (LSI, with typical frequency of 32 kHz)
- The high-speed external clock (HSE) divided by 32.

The RTC is functional in  $V_{BAT}$  mode and in all low-power modes when it is clocked by the LSE. When clocked by the LSI, the RTC is not functional in  $V_{BAT}$  mode, but is functional in all low-power modes.

All RTC events (Alarm, Wakeup Timer, Timestamp or Tamper) can generate an interrupt and wakeup the device from the low-power modes.

### 3.31 Inter-integrated circuit interface (I2C)

STM32H750xB devices embed four I<sup>2</sup>C interfaces.

The I<sup>2</sup>C bus interface handles communications between the microcontroller and the serial I<sup>2</sup>C bus. It controls all I<sup>2</sup>C bus-specific sequencing, protocol, arbitration and timing.

The I2C peripheral supports:

- I<sup>2</sup>C-bus specification and user manual rev. 5 compatibility:
  - Slave and Master modes, multimaster capability
  - Standard-mode (Sm), with a bitrate up to 100 kbit/s
  - Fast-mode (Fm), with a bitrate up to 400 kbit/s
  - Fast-mode Plus (Fm+), with a bitrate up to 1 Mbit/s and 20 mA output drive I/Os
  - 7-bit and 10-bit addressing mode, multiple 7-bit slave addresses
  - Programmable setup and hold times
  - Optional clock stretching
- System Management Bus (SMBus) specification rev 2.0 compatibility:
  - Hardware PEC (Packet Error Checking) generation and verification with ACK control
  - Address resolution protocol (ARP) support
  - SMBus alert
- Power System Management Protocol (PMBus™) specification rev 1.1 compatibility
- Independent clock: a choice of independent clock sources allowing the I2C communication speed to be independent from the PCLK reprogramming.
- Wakeup from Stop mode on address match
- Programmable analog and digital noise filters
- 1-byte buffer with DMA capability

### 3.32 Universal synchronous/asynchronous receiver transmitter (USART)

STM32H750xB devices have four embedded universal synchronous receiver transmitters (USART1, USART2, USART3 and USART6) and four universal asynchronous receiver transmitters (UART4, UART5, UART7 and UART8). Refer to [Table 5](#) for a summary of USARTx and UARTx features.

These interfaces provide asynchronous communication, IrDA SIR ENDEC support, multiprocessor communication mode, single-wire Half-duplex communication mode and have LIN Master/Slave capability. They provide hardware management of the CTS and RTS signals, and RS485 Driver Enable. They are able to communicate at speeds of up to 12.5 Mbit/s.

USART1, USART2, USART3 and USART6 also provide Smartcard mode (ISO 7816 compliant) and SPI-like communication capability.

The USARTs embed a Transmit FIFO (TXFIFO) and a Receive FIFO (RXFIFO). FIFO mode is enabled by software and is disabled by default.

All USART have a clock domain independent from the CPU clock, allowing the USARTx to wake up the MCU from Stop mode. The wakeup from Stop mode is programmable and can be done on:

- Start bit detection
- Any received data frame
- A specific programmed data frame
- Specific TXFIFO/RXFIFO status when FIFO mode is enabled.

All USART interfaces can be served by the DMA controller.

**Table 5. USART features**

USART modes/features <sup>(1)</sup>	USART1/2/3/6	UART4/5/7/8
Hardware flow control for modem	X	X
Continuous communication using DMA	X	X
Multiprocessor communication	X	X
Synchronous mode (Master/Slave)	X	-
Smartcard mode	X	-
Single-wire Half-duplex communication	X	X
IrDA SIR ENDEC block	X	X
LIN mode	X	X
Dual clock domain and wakeup from low power mode	X	X
Receiver timeout interrupt	X	X
Modbus communication	X	X
Auto baud rate detection	X	X
Driver Enable	X	X
USART data length	7, 8 and 9 bits	
Tx/Rx FIFO	X	X
Tx/Rx FIFO size	16	

1. X = supported.

### 3.33 Low-power universal asynchronous receiver transmitter (LPUART)

The device embeds one Low-Power UART (LPUART1). The LPUART supports asynchronous serial communication with minimum power consumption. It supports half duplex single wire communication and modem operations (CTS/RTS). It allows multiprocessor communication.

The LPUARTs embed a Transmit FIFO (TXFIFO) and a Receive FIFO (RXFIFO). FIFO mode is enabled by software and is disabled by default.

The LPUART has a clock domain independent from the CPU clock, and can wakeup the system from Stop mode. The wakeup from Stop mode are programmable and can be done on:

- Start bit detection
- Any received data frame
- A specific programmed data frame
- Specific TXFIFO/RXFIFO status when FIFO mode is enabled.

Only a 32.768 kHz clock (LSE) is needed to allow LPUART communication up to 9600 baud. Therefore, even in Stop mode, the LPUART can wait for an incoming frame while having an extremely low energy consumption. Higher speed clock can be used to reach higher baudrates.

LPUART interface can be served by the DMA controller.

### 3.34 Serial peripheral interfaces (SPI)/integrated interchip sound interfaces (I2S)

The devices feature up to six SPIs (SPI2S1, SPI2S2, SPI2S3, SPI4, SPI5 and SPI6) that allow communicating up to 150 Mbits/s in Master and Slave modes, in Half-duplex, Full-duplex and Simplex modes. The 3-bit prescaler gives 8 master mode frequencies and the frame is configurable from 4 to 16 bits. All SPI interfaces support NSS pulse mode, TI mode, Hardware CRC calculation and 8x 8-bit embedded Rx and Tx FIFOs with DMA capability.

Three standard I<sup>2</sup>S interfaces (multiplexed with SPI1, SPI2 and SPI3) are available. They can be operated in Master or Slave mode, in Simplex communication modes, and can be configured to operate with a 16-/32-bit resolution as an input or output channel. Audio sampling frequencies from 8 kHz up to 192 kHz are supported. When either or both of the I<sup>2</sup>S interfaces is/are configured in Master mode, the master clock can be output to the external DAC/CODEC at 256 times the sampling frequency. All I<sup>2</sup>S interfaces support 16x 8-bit embedded Rx and Tx FIFOs with DMA capability.

### 3.35 Serial audio interfaces (SAI)

The devices embed 4 SAIs (SAI1, SAI2, SAI3 and SAI4) that allow designing many stereo or mono audio protocols such as I2S, LSB or MSB-justified, PCM/DSP, TDM or AC'97. An SPDIF output is available when the audio block is configured as a transmitter. To bring this level of flexibility and reconfigurability, the SAI contains two independent audio sub-blocks. Each block has its own clock generator and I/O line controller.

Audio sampling frequencies up to 192 kHz are supported.

In addition, up to 8 microphones can be supported thanks to an embedded PDM interface. The SAI can work in master or slave configuration. The audio sub-blocks can be either receiver or transmitter and can work synchronously or asynchronously (with respect to the other one). The SAI can be connected with other SAIs to work synchronously.

### 3.36 SPDIFRX Receiver Interface (SPDIFRX)

The SPDIFRX peripheral is designed to receive an S/PDIF flow compliant with IEC-60958 and IEC-61937. These standards support simple stereo streams up to high sample rate, and compressed multi-channel surround sound, such as those defined by Dolby or DTS (up to 5.1).

The main SPDIFRX features are the following:

- Up to 4 inputs available
- Automatic symbol rate detection
- Maximum symbol rate: 12.288 MHz
- Stereo stream from 32 to 192 kHz supported
- Supports Audio IEC-60958 and IEC-61937, consumer applications
- Parity bit management
- Communication using DMA for audio samples
- Communication using DMA for control and user channel information
- Interrupt capabilities

The SPDIFRX receiver provides all the necessary features to detect the symbol rate, and decode the incoming data stream. The user can select the wanted SPDIF input, and when a valid signal will be available, the SPDIFRX will re-sample the incoming signal, decode the Manchester stream, recognize frames, sub-frames and blocks elements. It delivers to the CPU decoded data, and associated status flags.

The SPDIFRX also offers a signal named `spdif_frame_sync`, which toggles at the S/PDIF sub-frame rate that will be used to compute the exact sample rate for clock drift algorithms.

### 3.37 Single wire protocol master interface (SWPMI)

The Single wire protocol master interface (SWPMI) is the master interface corresponding to the Contactless Frontend (CLF) defined in the ETSI TS 102 613 technical specification. The main features are:

- Full-duplex communication mode
- automatic SWP bus state management (active, suspend, resume)
- configurable bitrate up to 2 Mbit/s
- automatic SOF, EOF and CRC handling

SWPMI can be served by the DMA controller.



### 3.38 Management Data Input/Output (MDIO) slaves

The devices embed an MDIO slave interface it includes the following features:

- 32 MDIO Registers addresses, each of which is managed using separate input and output data registers:
  - 32 x 16-bit firmware read/write, MDIO read-only output data registers
  - 32 x 16-bit firmware read-only, MDIO write-only input data registers
- Configurable slave (port) address
- Independently maskable interrupts/events:
  - MDIO Register write
  - MDIO Register read
  - MDIO protocol error
- Able to operate in and wake up from Stop mode

### 3.39 SD/SDIO/MMC card host interfaces (SDMMC)

Two SDMMC host interfaces are available. They support *MultiMediaCard System Specification Version 4.51* in three different databus modes: 1 bit (default), 4 bits and 8 bits.

Both interfaces support the *SD memory card specifications version 4.1*. and the *SDIO card specification version 4.0*. in two different databus modes: 1 bit (default) and 4 bits.

Each SDMMC host interface supports only one SD/SDIO/MMC card at any one time and a stack of MMC Version 4.51 or previous.

The SDMMC host interface embeds a dedicated DMA controller allowing high-speed transfers between the interface and the SRAM.

### 3.40 Controller area network (FDCAN1, FDCAN2)

The controller area network (CAN) subsystem consists of two CAN modules, a shared message RAM memory and a clock calibration unit.

Both CAN modules (FDCAN1 and FDCAN2) are compliant with ISO 11898-1 (CAN protocol specification version 2.0 part A, B) and CAN FD protocol specification version 1.0.

FDCAN1 supports time triggered CAN (TT-FDCAN) specified in ISO 11898-4, including event synchronized time-triggered communication, global system time, and clock drift compensation. The FDCAN1 contains additional registers, specific to the time triggered feature. The CAN FD option can be used together with event-triggered and time-triggered CAN communication.

A 10-Kbyte message RAM memory implements filters, receive FIFOs, receive buffers, transmit event FIFOs, transmit buffers (and triggers for TT-FDCAN). This message RAM is shared between the two FDCAN1 and FDCAN2 modules.

The common clock calibration unit is optional. It can be used to generate a calibrated clock for both FDCAN1 and FDCAN2 from the HSI internal RC oscillator and the PLL, by evaluating CAN messages received by the FDCAN1.

### 3.41 Universal serial bus on-the-go high-speed (OTG\_HS)

The devices embed two USB OTG high-speed (up to 480 Mbit/s) device/host/OTG peripheral. OTG-HS1 supports both full-speed and high-speed operations, while OTG-HS2 supports only full-speed operations. They both integrate the transceivers for full-speed operation (12 Mbit/s) and are able to operate from the internal HSI48 oscillator. OTG-HS1 features a UTMI low-pin interface (ULPI) for high-speed operation (480 Mbit/s). When using the USB OTG-HS1 in HS mode, an external PHY device connected to the ULPI is required.

The USB OTG HS peripherals are compliant with the USB 2.0 specification and with the OTG 2.0 specification. They have software-configurable endpoint setting and supports suspend/resume. The USB OTG controllers require a dedicated 48 MHz clock that is generated by a PLL connected to the HSE oscillator.

The main features are:

- Combined Rx and Tx FIFO size of 4 Kbytes with dynamic FIFO sizing
- Supports the session request protocol (SRP) and host negotiation protocol (HNP)
- 9 bidirectional endpoints (including EP0)
- 16 host channels with periodic OUT support
- Software configurable to OTG1.3 and OTG2.0 modes of operation
- USB 2.0 LPM (Link Power Management) support
- Battery Charging Specification Revision 1.2 support
- Internal FS OTG PHY support
- External HS or HS OTG operation supporting ULPI in SDR mode (OTG\_HS1 only)

The OTG PHY is connected to the microcontroller ULPI port through 12 signals. It can be clocked using the 60 MHz output.

- Internal USB DMA
- HNP/SNP/IP inside (no need for any external resistor)
- For OTG/Host modes, a power switch is needed in case bus-powered devices are connected

### 3.42 Ethernet MAC interface with dedicated DMA controller (ETH)

The devices provide an IEEE-802.3-2002-compliant media access controller (MAC) for ethernet LAN communications through an industry-standard medium-independent interface (MII) or a reduced medium-independent interface (RMII). The microcontroller requires an external physical interface device (PHY) to connect to the physical LAN bus (twisted-pair, fiber, etc.). The PHY is connected to the device MII port using 17 signals for MII or 9 signals for RMII, and can be clocked using the 25 MHz (MII) from the microcontroller.

The devices include the following features:

- Supports 10 and 100 Mbit/s rates
- Dedicated DMA controller allowing high-speed transfers between the dedicated SRAM and the descriptors
- Tagged MAC frame support (VLAN support)
- Half-duplex (CSMA/CD) and full-duplex operation
- MAC control sublayer (control frames) support
- 32-bit CRC generation and removal
- Several address filtering modes for physical and multicast address (multicast and group addresses)
- 32-bit status code for each transmitted or received frame
- Internal FIFOs to buffer transmit and receive frames. The transmit FIFO and the receive FIFO are both 2 Kbytes.
- Supports hardware PTP (precision time protocol) in accordance with IEEE 1588 2008 (PTP V2) with the time stamp comparator connected to the TIM2 input
- Triggers interrupt when system time becomes greater than target time

### 3.43 High-definition multimedia interface (HDMI) - consumer electronics control (CEC)

The devices embed a HDMI-CEC controller that provides hardware support for the Consumer Electronics Control (CEC) protocol (Supplement 1 to the HDMI standard).

This protocol provides high-level control functions between all audiovisual products in an environment. It is specified to operate at low speeds with minimum processing and memory overhead. It has a clock domain independent from the CPU clock, allowing the HDMI-CEC controller to wakeup the MCU from Stop mode on data reception.

### 3.44 Debug infrastructure

The devices offer a comprehensive set of debug and trace features to support software development and system integration.

- Breakpoint debugging
- Code execution tracing
- Software instrumentation
- JTAG debug port
- Serial-wire debug port
- Trigger input and output
- Serial-wire trace port
- Trace port
- Arm® CoreSight™ debug and trace components

The debug can be controlled via a JTAG/Serial-wire debug access port, using industry standard debugging tools.

The trace port performs data capture for logging and analysis.

## 4 Memory mapping

Refer to the product line reference manual for details on the memory mapping as well as the boundary addresses for all peripherals.

# 5 Pin descriptions

Figure 4. LQFP100 pinout

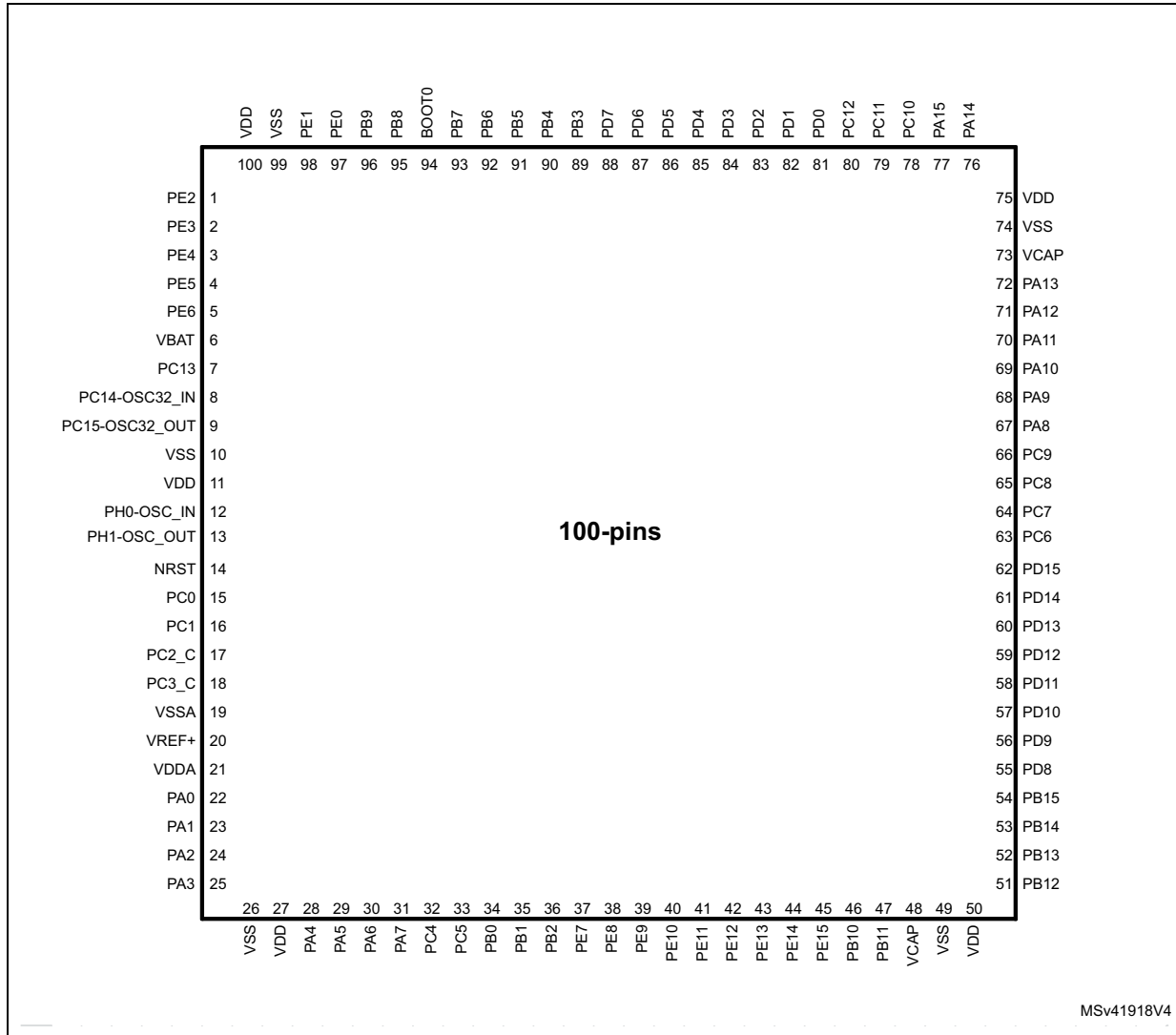

1. The above figure shows the package top view.

Figure 5. LQFP144 pinout

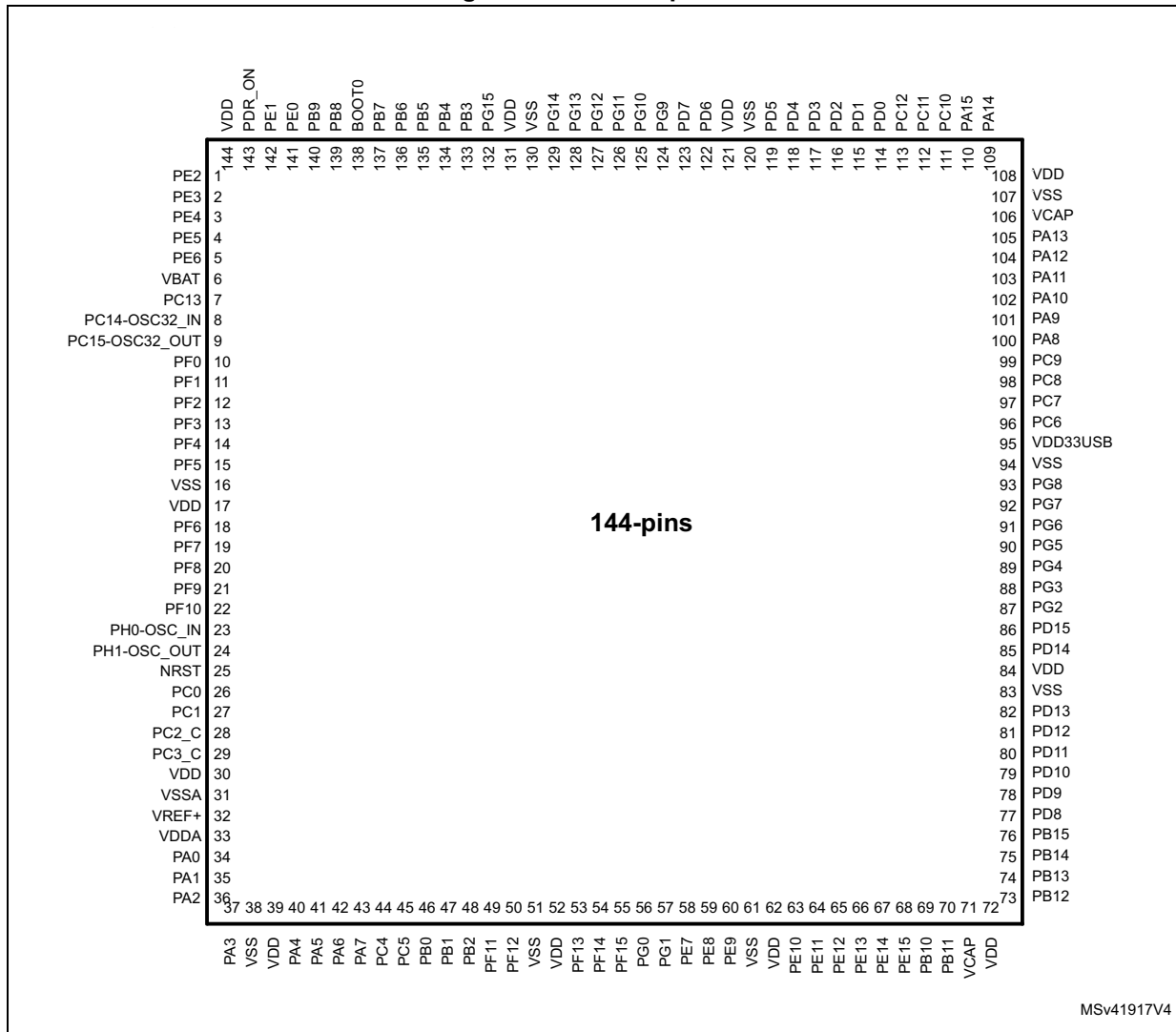

1. The above figure shows the package top view.

Figure 6. LQFP176 pinout

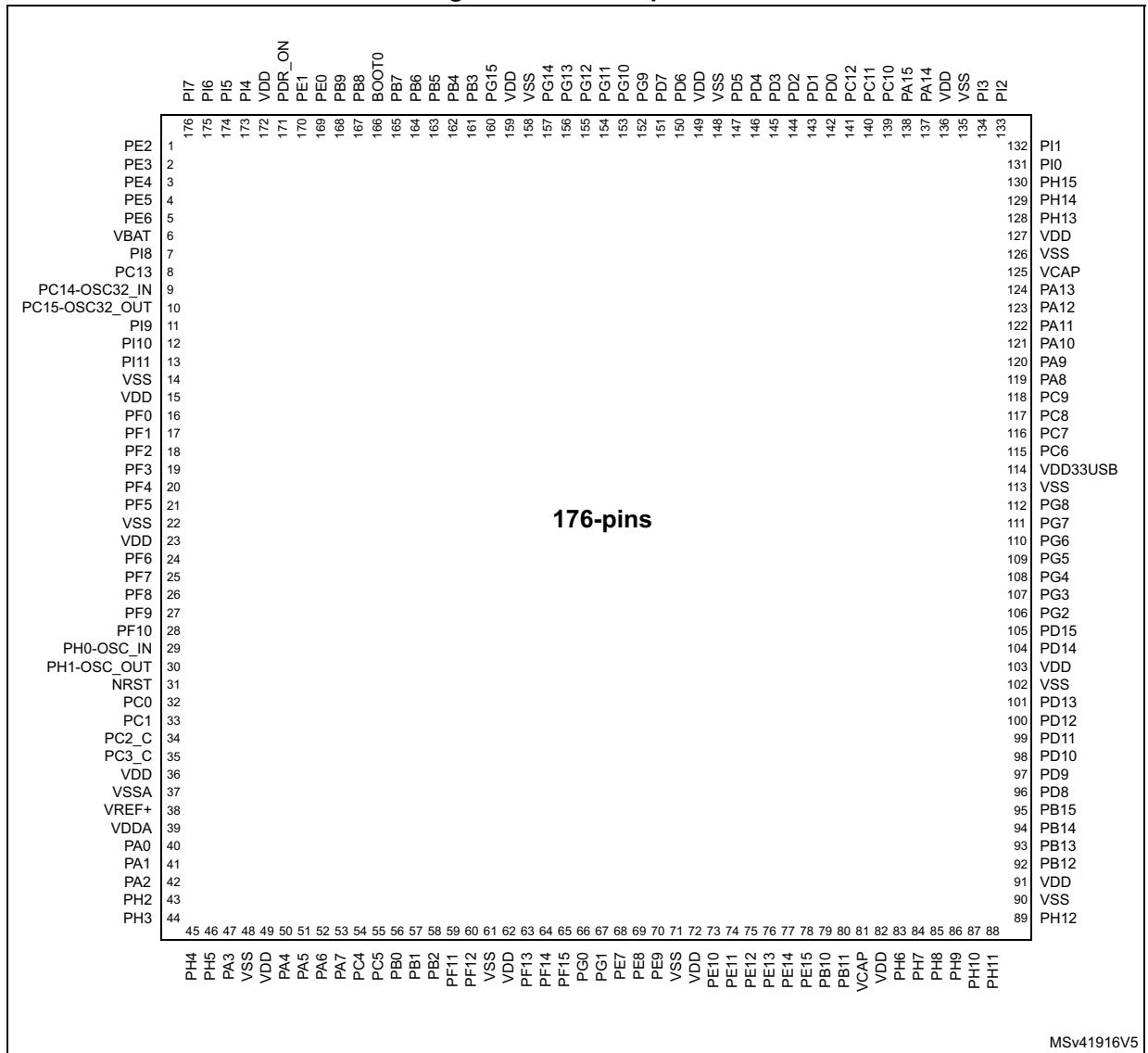

1. The above figure shows the package top view.

Figure 7. UFBGA176+25 ballout

	1	2	3	4	5	6	7	8	9	10	11	12	13	14	15
A	PE3	PE2	PE1	PE0	PB8	PB5	PG14	PG13	PB4	PB3	PD7	PC12	PA15	PA14	PA13
B	PE4	PE5	PE6	PB9	PB7	PB6	PG15	PG12	PG11	PG10	PD6	PD0	PC11	PC10	PA12
C	VBAT	PI7	PI6	PI5	VDD	PDR_ON	VDD	VDD	VDD	PG9	PD5	PD1	PI3	PI2	PA11
D	PC13	PI8	PI9	PI4	VSS	BOOT0	VSS	VSS	VSS	PD4	PD3	PD2	PH15	PI1	PA10
E	PC14- OSC32_ IN	PF0	PI10	PI11								PH13	PH14	PI0	PA9
F	PC15- OSC32_ OUT	VSS	VDD	PH2		VSS	VSS	VSS	VSS	VSS		VSS	VCAP	PC9	PA8
G	PH0- OSC_IN	VSS	VDD	PH3		VSS	VSS	VSS	VSS	VSS		VSS	VDD	PC8	PC7
H	PH1- OSC_ OUT	PF2	PF1	PH4		VSS	VSS	VSS	VSS	VSS		VSS	VDD 33USB	PG8	PC6
J	NRST	PF3	PF4	PH5		VSS	VSS	VSS	VSS	VSS		VDD	VDD	PG7	PG6
K	PF7	PF6	PF5	VDD		VSS	VSS	VSS	VSS	VSS		PH12	PG5	PG4	PG3
L	PF10	PF9	PF8	VSS								PH11	PH10	PD15	PG2
M	VSSA	PC0	PC1	PC2_C	PC3_C	PB2	PG1	VSS	VSS	VCAP	PH6	PH8	PH9	PD14	PD13
N	VREF-	PA1	PA0	PA4	PC4	PF13	PG0	VDD	VDD	VDD	PE13	PH7	PD12	PD11	PD10
P	VREF+	PA2	PA6	PA5	PC5	PF12	PF15	PE8	PE9	PE11	PE14	PB12	PB13	PD9	PD8
R	VDDA	PA3	PA7	PB1	PB0	PF11	PF14	PE7	PE10	PE12	PE15	PB10	PB11	PB14	PB15

MSv41912V3

1. The above figure shows the package top view.



Figure 8. TFBGA240+25 ballout

	1	2	3	4	5	6	7	8	9	10	11	12	13	14	15	16	17
A	VSS	PI6	PI5	PI4	PB5	VDD LDO	VCAP	PK5	PG10	PG9	PD5	PD4	PC10	PA15	PI1	PI0	VSS
B	VBAT	VSS	PI7	PE1	PB6	VSS	PB4	PK4	PG11	PJ15	PD6	PD3	PC11	PA14	PI2	PH15	PH14
C	PC15-OSC32_OUT	PC14-OSC32_IN	PE2	PE0	PB7	PB3	PK6	PK3	PG12	VSS	PD7	PC12	VSS	PI3	PA13	VSS	VDD LDO
D	PE5	PE4	PE3	PB9	PB8	PG15	PK7	PG14	PG13	PJ14	PJ12	PD2	PD0	PA10	PA9	PH13	VCAP
E	NC	PI9	PC13	PI8	PE6	VDD	PDR_ON	BOOT0	VDD	PJ13	VDD	PD1	PC8	PC9	PA8	PA12	PA11
F	NC	NC	PI10	PI11	VDD								PC7	PC6	PG8	PG7	VDD33 USB
G	PF2	NC	PF1	PF0	VDD		VSS	VSS	VSS	VSS	VSS		VDD	PG5	PG6	VSS	VDD50 USB
H	PI12	PI13	PI14	PF3	VDD		VSS	VSS	VSS	VSS	VSS		VDD	PG4	PG3	PG2	PK2
J	PH0-OSC_OUT	PH0-OSC_IN	VSS	PF5	PF4		VSS	VSS	VSS	VSS	VSS		VDD	PK0	PK1	VSS	VSS
K	NRST	PF6	PF7	PF8	VDD		VSS	VSS	VSS	VSS	VSS		VDD	PJ11	VSS	NC	NC
L	VDDA	PC0	PF10	PF9	VDD		VSS	VSS	VSS	VSS	VSS		VDD	PJ10	VSS	NC	NC
M	VREF+	PC1	PC2	PC3	VDD								VDD	PJ9	VSS	NC	NC
N	VREF-	PH2	PA2	PA1	PA0	PJ0	VDD	VDD	PE10	VDD	VDD	VDD	PJ8	PJ7	PJ6	VSS	NC
P	VSSA	PH3	PH4	PH5	PI15	PJ1	PF13	PF14	PE9	PE11	PB10	PB11	PH10	PH11	PD15	PD14	VDD
R	PC2_C	PC3_C	PA6	VSS	PA7	PB2	PF12	VSS	PF15	PE12	PE15	PJ5	PH9	PH12	PD11	PD12	PD13
T	PA0_C	PA1_C	PA5	PC4	PB1	PJ2	PF11	PG0	PE8	PE13	PH6	VSS	PH8	PB12	PB15	PD10	PD9
U	VSS	PA3	PA4	PC5	PB0	PJ3	PJ4	PG1	PE7	PE14	VCAP	VDD LDO	PH7	PB13	PB14	PD8	VSS

MSv41911V2

1. The above figure shows the package top view.

Table 6. Legend/abbreviations used in the pinout table

Name		Abbreviation	Definition
Pin name		Unless otherwise specified in brackets below the pin name, the pin function during and after reset is the same as the actual pin name	
Pin type		S	Supply pin
		I	Input only pin
		I/O	Input / output pin
		ANA	Analog-only Input
I/O structure		FT	5 V tolerant I/O
		TT	3.3 V tolerant I/O
		B	Dedicated BOOT0 pin
		RST	Bidirectional reset pin with embedded weak pull-up resistor
		<b>Option for TT and FT I/Os</b>	
		_f	I2C FM+ option
		_a	analog option (supplied by V <sub>DDA</sub> )
		_u	USB option (supplied by V <sub>DD33USB</sub> )
		_h	High-speed low-voltage I/O
Notes		Unless otherwise specified by a note, all I/Os are set as floating inputs during and after reset.	
Pin functions	Alternate functions	Functions selected through GPIOx_AFR registers	
	Additional functions	Functions directly selected/enabled through peripheral registers	

Table 7. STM32H750xB pin/ball definition

Pin/ball name					Pin name (function after reset)	Pin type	I/O structure	Notes	Alternate functions	Additional functions
LQFP100	LQFP144	UFBGA176+25	LQFP176	TFBGA240 +25						
1	1	A2	1	C3	PE2	I/O	FT_h	-	TRACECLK, SAI1_CK1, SPI4_SCK, SAI1_MCLK_A, SAI4_MCLK_A, QUADSPI_BK1_IO2, SAI4_CK1, ETH_MII_TXD3, FMC_A23, EVENTOUT	-
2	2	A1	2	D3	PE3	I/O	FT_h	-	TRACED0, TIM15_BKIN, SAI1_SD_B, SAI4_SD_B, FMC_A19, EVENTOUT	-
3	3	B1	3	D2	PE4	I/O	FT_h	-	TRACED1, SAI1_D2, DFSDM1_DATIN3, TIM15_CH1N, SPI4_NSS, SAI1_FS_A, SAI4_FS_A, SAI4_D2, FMC_A20, DCMI_D4, LCD_B0, EVENTOUT	-
4	4	B2	4	D1	PE5	I/O	FT_h	-	TRACED2, SAI1_CK2, DFSDM1_CKIN3, TIM15_CH1, SPI4_MISO, SAI1_SCK_A, SAI4_SCK_A, SAI4_CK2, FMC_A21, DCMI_D6, LCD_G0, EVENTOUT	-
5	5	B3	5	E5	PE6	I/O	FT_h	-	TRACED3, TIM1_BKIN2, SAI1_D1, TIM15_CH2, SPI4_MOSI, SAI1_SD_A, SAI4_SD_A, SAI4_D1, SAI2_MCLK_B, TIM1_BKIN2_COMP12, FMC_A22, DCMI_D7, LCD_G1, EVENTOUT	-
-	-	H10	-	A1	VSS	S	-	-	-	-
-	-	-	-	-	VDD	S	-	-	-	-
6	6	C1	6	B1	VBAT	S	-	-	-	-
-	-	J6	-	B2	VSS	S	-	-	-	-
-	-	D2	7	E4	PI8	I/O	FT	-	EVENTOUT	RTC_ TAMP2/ WKUP3
7	7	D1	8	E3	PC13	I/O	FT	-	EVENTOUT	RTC_ TAMP1/ RTC_TS/ WKUP2
-	-	J7	-	B6	VSS	S	-	-	-	-
8	8	E1	9	C2	PC14- OSC32_IN (OSC32_IN) <sup>(1)</sup>	I/O	FT	-	EVENTOUT	OSC32_IN

Table 7. STM32H750xB pin/ball definition (continued)

Pin/ball name					Pin name (function after reset)	Pin type	I/O structure	Notes	Alternate functions	Additional functions
LQFP100	LQFP144	UFBGA176+25	LQFP176	TFBGA240 +25						
9	9	F1	10	C1	PC15- OSC32_OUT (OSC32_OUT) <sup>(1)</sup>	I/O	FT	-	EVENTOUT	OSC32_ OUT
-	-	D3	11	E2	PI9	I/O	FT_h	-	UART4_RX, FDCAN1_RX, FMC_D30, LCD_VSYNC, EVENTOUT	-
-	-	E3	12	F3	PI10	I/O	FT_h	-	FDCAN1_RXFD_MODE, ETH_MII_RX_ER, FMC_D31, LCD_HSYNC, EVENTOUT	-
-	-	E4	13	F4	PI11	I/O	FT	-	LCD_G6, OTG_HS_ULPI_DIR, EVENTOUT	WKUP4
-	-	F2	14	A17	VSS	S	-	-	-	-
-	-	F3	15	E6	VDD	S	-	-	-	-
-	-	-	-	E1 <sup>(2)</sup>	NC	-	-	-	-	-
-	-	-	-	F1 <sup>(3)</sup>	NC	-	-	-	-	-
-	-	-	-	G2 <sup>(4)</sup>	NC	-	-	-	-	-
-	10	E2	16	G4	PF0	I/O	FT_f	-	I2C2_SDA, FMC_A0, EVENTOUT	-
-	11	H3	17	G3	PF1	I/O	FT_f	-	I2C2_SCL, FMC_A1, EVENTOUT	-
-	12	H2	18	G1	PF2	I/O	FT	-	I2C2_SMBA, FMC_A2, EVENTOUT	-
-	-	-	-	H1	PI12	I/O	FT	-	LCD_HSYNC, EVENTOUT	-
-	-	-	-	H2	PI13	I/O	FT	-	LCD_VSYNC, EVENTOUT	-
-	-	-	-	H3	PI14	I/O	FT_h	-	LCD_CLK, EVENTOUT	-
-	13	J2	19	H4	PF3	I/O	FT_ha	-	FMC_A3, EVENTOUT	ADC3_ INP5
-	14	J3	20	J5	PF4	I/O	FT_ha	-	FMC_A4, EVENTOUT	ADC3_ INN5, ADC3_ INP9
-	15	K3	21	J4	PF5	I/O	FT_ha	-	FMC_A5, EVENTOUT	ADC3_ INP4
10	16	G2	22	C10	VSS	S	-	-	-	-
11	17	G3	23	E9	VDD	S	-	-	-	-
-	18	K2	24	K2	PF6	I/O	FT_ha	-	TIM16_CH1, SPI5_NSS, SAI1_SD_B, UART7_RX, SAI4_SD_B, QUADSPI_BK1_IO3, EVENTOUT	ADC3_ INN4, ADC3_ INP8

Table 7. STM32H750xB pin/ball definition (continued)

Pin/ball name					Pin name (function after reset)	Pin type	I/O structure	Notes	Alternate functions	Additional functions
LQFP100	LQFP144	UFBGA176+25	LQFP176	TFBGA240 +25						
-	19	K1	25	K3	PF7	I/O	FT_ha	-	TIM17_CH1, SPI5_SCK, SAI1_MCLK_B, UART7_TX, SAI4_MCLK_B, QUADSPI_BK1_IO2, EVENTOUT	ADC3_ INP3
-	20	L3	26	K4	PF8	I/O	FT_ha	-	TIM16_CH1N, SPI5_MISO, SAI1_SCK_B, UART7_RTS/UART7_DE, SAI4_SCK_B, TIM13_CH1, QUADSPI_BK1_IO0, EVENTOUT	ADC3_ INN3, ADC3_ INP7
-	21	L2	27	L4	PF9	I/O	FT_ha	-	TIM17_CH1N, SPI5_MOSI, SAI1_FS_B, UART7_CTS, SAI4_FS_B, TIM14_CH1, QUADSPI_BK1_IO1, EVENTOUT	ADC3_ INP2
-	22	L1	28	L3	PF10	I/O	FT_ha	-	TIM16_BKIN, SAI1_D3, QUADSPI_CLK, SAI4_D3, DCMI_D11, LCD_DE, EVENTOUT	ADC3_ INN2, ADC3_ INP6
12	23	G1	29	J2	PH0-OSC_IN (PH0)	I/O	FT	-	EVENTOUT	OSC_IN
13	24	H1	30	J1	PH1-OSC_OUT (PH1)	I/O	FT	-	EVENTOUT	OSC_OUT
14	25	J1	31	K1	NRST	I/O	RST	-	-	-
15	26	M2	32	L2	PC0	I/O	FT_a	-	DFSDM1_CKIN0, DFSDM1_DATIN4, SAI2_FS_B, OTG_HS_ULPI_STP, FMC_SDNWE, LCD_R5, EVENTOUT	ADC123_ INP10
16	27	M3	33	M2	PC1	I/O	FT_ha	-	TRACED0, SAI1_D1, DFSDM1_DATIN0, DFSDM1_CKIN4, SPI2_MOSI/I2S2_SDO, SAI1_SD_A, SAI4_SD_A, SDMMC2_CK, SAI4_D1, ETH_MDC, MDIOS_MDC, EVENTOUT	ADC123_ INN10, ADC123_ INP11, RTC_ TAMP3/ WKUP5
-	-	-	-	M3 <sup>(5)</sup>	PC2	I/O	FT_a	-	CDSLEEP, DFSDM1_CKIN1, SPI2_MISO/I2S2_SDI, DFSDM1_CKOUT, OTG_HS_ULPI_DIR, ETH_MII_TXD2, FMC_SDNE0, EVENTOUT	ADC123_ INN11, ADC123_ INP12
17 <sup>(6)</sup>	28 <sup>(6)</sup>	M4 <sup>(6)</sup>	34 <sup>(6)</sup>	R1 <sup>(5)</sup>	PC2_C	ANA	TT_a	-		ADC3_ INN1, ADC3_ INP0

Table 7. STM32H750xB pin/ball definition (continued)

Pin/ball name					Pin name (function after reset)	Pin type	I/O structure	Notes	Alternate functions	Additional functions
LQFP100	LQFP144	UFBGA176+25	LQFP176	TFBGA240 +25						
-	-	-	-	M4 <sup>(5)</sup>	PC3	I/O	FT_a	-	CSLEEP, DFSDM1_DATIN1, SPI2_MOSI/I2S2_SDO, OTG_HS_ULPI_NXT, ETH_MII_TX_CLK, FMC_SDCKE0, EVENTOUT	ADC12_ INN12, ADC12_ INP13
18 <sup>(6)</sup>	29 <sup>(6)</sup>	M5 <sup>(6)</sup>	35 <sup>(6)</sup>	R2 <sup>(5)</sup>	PC3_C	ANA	TT_a	-		ADC3_ INP1
-	30	G3	36	E11	VDD	S	-	-		-
-	-	J10	-	C13	VSS	S	-	-	-	-
19	31	M1	37	P1	VSSA	S	-	-	-	-
-	-	N1	-	N1	VREF-	S	-	-	-	-
20	32	P1	38	M1	VREF+	S	-	-	-	-
21	33	R1	39	L1	VDDA	S	-	-	-	-
22	34	N3	40	N5 <sup>(5)</sup>	PA0	I/O	FT_a	-	TIM2_CH1/TIM2_ETR, TIM5_CH1, TIM8_ETR, TIM15_BKIN, USART2_CTS/USART2_NSS, UART4_TX, SDMMC2_CMD, SAI2_SD_B, ETH_MII_CR0, EVENTOUT	ADC1_ INP16, WKUP0
-	-	-	-	T1 <sup>(5)</sup>	PA0_C	ANA	TT_a	-		ADC12_ INN1, ADC12_ INP0
23	35	N2	41	N4 <sup>(5)</sup>	PA1	I/O	FT_ha	-	TIM2_CH2, TIM5_CH2, LPTIM3_OUT, TIM15_CH1N, USART2_RTS/USART2_DE, UART4_RX, QUADSPI_BK1_IO3, SAI2_MCLK_B, ETH_MII_RX_CLK/ETH_RMII_RE F_CLK, LCD_R2, EVENTOUT	ADC1_ INN16, ADC1_ INP17
-	-	-	-	T2 <sup>(5)</sup>	PA1_C	ANA	TT_a	-		ADC12_ INP1
24	36	P2	42	N3	PA2	I/O	FT_a	-	TIM2_CH3, TIM5_CH3, LPTIM4_OUT, TIM15_CH1, USART2_TX, SAI2_SCK_B, ETH_MDIO, MDIOS_MDIO, LCD_R1, EVENTOUT	ADC12_ INP14, WKUP1
-	-	F4	43	N2	PH2	I/O	FT_ha	-	LPTIM1_IN2, QUADSPI_BK2_IO0, SAI2_SCK_B, ETH_MII_CR0, FMC_SDCKE0, LCD_R0, EVENTOUT	ADC3_ INP13
-	-	-	-	F5	VDD	S	-	-	-	-
-	-	J8	-	C16	VSS	S	-	-	-	-

Table 7. STM32H750xB pin/ball definition (continued)

Pin/ball name					Pin name (function after reset)	Pin type	I/O structure	Notes	Alternate functions	Additional functions
LQFP100	LQFP144	UFBGA176+25	LQFP176	TFBGA240 +25						
-	-	G4	44	P2	PH3	I/O	FT_ha	-	QUADSPI_BK2_IO1, SAI2_MCLK_B, ETH_MII_COL, FMC_SDNE0, LCD_R1, EVENTOUT	ADC3_ INN13, ADC3_ INP14
-	-	H4	45	P3	PH4	I/O	FT_fa	-	I2C2_SCL, LCD_G5, OTG_HS_ULPI_NXT, LCD_G4, EVENTOUT	ADC3_ INN14, ADC3_ INP15
-	-	J4	46	P4	PH5	I/O	FT_fa	-	I2C2_SDA, SPI5_NSS, FMC_SDNWE, EVENTOUT	ADC3_ INN15, ADC3_ INP16
25	37	R2	47	U2	PA3	I/O	FT_ha	-	TIM2_CH4, TIM5_CH4, LPTIM5_OUT, TIM15_CH2, USART2_RX, LCD_B2, OTG_HS_ULPI_D0, ETH_MII_COL, LCD_B5, EVENTOUT	ADC12_ INP15
26	38	K6	-	F2 <sup>(4)</sup>	VSS	S	-	-	-	-
-	-	L4	48	-	VSS	S	-	-	-	-
27	39	K4	49	G5	VDD	S	-	-	-	-
28	40	N4	50	U3	PA4	I/O	TT_a	-	D1PWREN, TIM5_ETR, SPI1_NSS/I2S1_WS, SPI3_NSS/I2S3_WS, USART2_CK, SPI6_NSS, OTG_HS_SOF, DCMI_HSYNC, LCD_VSYNC, EVENTOUT	ADC12_ INP18, DAC1_ OUT1
29	41	P4	51	T3	PA5	I/O	TT_ha	-	D2PWREN, TIM2_CH1/TIM2_ETR, TIM8_CH1N, SPI1_SCK/I2S1_CK, SPI6_SCK, OTG_HS_ULPI_CK, LCD_R4, EVENTOUT	ADC12_ INN18, ADC12_ INP19, DAC1_ OUT2
30	42	P3	52	R3	PA6	I/O	FT_a	-	TIM1_BKIN, TIM3_CH1, TIM8_BKIN, SPI1_MISO/I2S1_SDI, SPI6_MISO, TIM13_CH1, TIM8_BKIN_COMP12, MDIOS_MDC, TIM1_BKIN_COMP12, DCMI_PIXCLK, LCD_G2, EVENTOUT	ADC12_ INP3

Table 7. STM32H750xB pin/ball definition (continued)

Pin/ball name					Pin name (function after reset)	Pin type	I/O structure	Notes	Alternate functions	Additional functions
LQFP100	LQFP144	UFBGA176+25	LQFP176	TFBGA240 +25						
31	43	R3	53	R5	PA7	I/O	TT_a	-	TIM1_CH1N, TIM3_CH2, TIM8_CH1N, SPI1_MOSI/I2S1_SDO, SPI6_MOSI, TIM14_CH1, ETH_MII_RX_DV/ETH_RMII_CRS _DV, FMC_SDNWE, EVENTOUT	ADC12_ INN3, ADC12_ INP7, OPAMP1_ VINM
32	44	N5	54	T4	PC4	I/O	TT_a	-	DFSDM1_CKIN2, I2S1_MCK, SPDIFRX1_IN3, ETH_MII_RXD0/ETH_RMII_RXD0 , FMC_SDNE0, EVENTOUT	ADC12_ INP4, OPAMP1_ VOUT, COMP1_ INM
33	45	P5	55	U4	PC5	I/O	TT_a	-	SAI1_D3, DFSDM1_DATIN2, SPDIFRX1_IN4, SAI4_D3, ETH_MII_RXD1/ETH_RMII_RXD1 , FMC_SDCKE0, COMP1_OUT, EVENTOUT	ADC12_ INN4, ADC12_ INP8, OPAMP1_ VINM
-	-	-	-	G13	VDD	S	-	-	-	-
-	-	J9	-	R4	VSS	S	-	-	-	-
34	46	R5	56	U5	PB0	I/O	FT_a	-	TIM1_CH2N, TIM3_CH3, TIM8_CH2N, DFSDM1_CKOUT, UART4_CTS, LCD_R3, OTG_HS_ULPI_D1, ETH_MII_RXD2, LCD_G1, EVENTOUT	ADC12_ INN5, ADC12_ INP9, OPAMP1_ VINP, COMP1_ INP
35	47	R4	57	T5	PB1	I/O	TT_u	-	TIM1_CH3N, TIM3_CH4, TIM8_CH3N, DFSDM1_DATIN1, LCD_R6, OTG_HS_ULPI_D2, ETH_MII_RXD3, LCD_G0, EVENTOUT	ADC12_ INP5, COMP1_ INM
36	48	M6	58	R6	PB2	I/O	FT_ha	-	RTC_OUT, SAI1_D1, DFSDM1_CKIN1, SAI1_SD_A, SPI3_MOSI/I2S3_SDO, SAI4_SD_A, QUADSPI_CLK, SAI4_D1, EVENTOUT	COMP1_ INP
-	-	-	-	P5	PI15	I/O	FT	-	LCD_G2, LCD_R0, EVENTOUT	-
-	-	-	-	N6	PJ0	I/O	FT	-	LCD_R7, LCD_R1, EVENTOUT	-
-	-	-	-	P6	PJ1	I/O	FT	-	LCD_R2, EVENTOUT	-
-	-	-	-	T6	PJ2	I/O	FT	-	LCD_R3, EVENTOUT	-
-	-	-	-	U6	PJ3	I/O	FT	-	LCD_R4, EVENTOUT	-



Table 7. STM32H750xB pin/ball definition (continued)

Pin/ball name					Pin name (function after reset)	Pin type	I/O structure	Notes	Alternate functions	Additional functions
LQFP100	LQFP144	UFBGA176+25	LQFP176	TFBGA240 +25						
-	-	-	-	U7	PJ4	I/O	FT	-	LCD_R5, EVENTOUT	-
-	49	R6	59	T7	PF11	I/O	FT_a	-	SPI5_MOSI, SAI2_SD_B, FMC_SDNRAS, DCMI_D12, EVENTOUT	ADC1_ INP2
-	50	P6	60	R7	PF12	I/O	FT_ha	-	FMC_A6, EVENTOUT	ADC1_ INN2, ADC1_ INP6
-	51	M8	61	J3	VSS	S	-	-	-	-
-	52	N8	62	H5	VDD	S	-	-	-	-
-	53	N6	63	P7	PF13	I/O	FT_ha	-	DFSDM1_DATIN6, I2C4_SMBA, FMC_A7, EVENTOUT	ADC2_ INP2
-	54	R7	64	P8	PF14	I/O	FT_fha	-	DFSDM1_CKIN6, I2C4_SCL, FMC_A8, EVENTOUT	ADC2_ INN2, ADC2_ INP6
-	55	P7	65	R9	PF15	I/O	FT_fh	-	I2C4_SDA, FMC_A9, EVENTOUT	-
-	56	N7	66	T8	PG0	I/O	FT_h	-	FMC_A10, EVENTOUT	-
-	-	F6	-	J16	VSS	S	-	-	-	-
-	-	-	-	H13	VDD	S	-	-	-	-
-	57	M7	67	U8	PG1	I/O	TT_h	-	FMC_A11, EVENTOUT	OPAMP2_ VINM
37	58	R8	68	U9	PE7	I/O	TT_ha	-	TIM1_ETR, DFSDM1_DATIN2, UART7_RX, QUADSPI_BK2_IO0, FMC_D4/FMC_DA4, EVENTOUT	OPAMP2_ VOUT, COMP2_ INM
38	59	P8	69	T9	PE8	I/O	TT_ha	-	TIM1_CH1N, DFSDM1_CKIN2, UART7_TX, QUADSPI_BK2_IO1, FMC_D5/FMC_DA5, COMP2_OUT, EVENTOUT	OPAMP2_ VINM
39	60	P9	70	P9	PE9	I/O	TT_ha	-	TIM1_CH1, DFSDM1_CKOUT, UART7_RTS/UART7_DE, QUADSPI_BK2_IO2, FMC_D6/FMC_DA6, EVENTOUT	OPAMP2_ VINP, COMP2_ INP
-	61	M9	71	J17	VSS	S	-	-	-	-
-	62	N9	72	J13	VDD	S	-	-	-	-
40	63	R9	73	N9	PE10	I/O	FT_ha	-	TIM1_CH2N, DFSDM1_DATIN4, UART7_CTS, QUADSPI_BK2_IO3, FMC_D7/FMC_DA7, EVENTOUT	COMP2_ INM

Table 7. STM32H750xB pin/ball definition (continued)

Pin/ball name					Pin name (function after reset)	Pin type	I/O structure	Notes	Alternate functions	Additional functions
LQFP100	LQFP144	UFBGA176+25	LQFP176	TFBGA240 +25						
41	64	P10	74	P10	PE11	I/O	FT_ha	-	TIM1_CH2, DFSDM1_CKIN4, SPI4_NSS, SAI2_SD_B, FMC_D8/FMC_DA8, LCD_G3, EVENTOUT	COMP2_ INP
42	65	R10	75	R10	PE12	I/O	FT_h	-	TIM1_CH3N, DFSDM1_DATIN5, SPI4_SCK, SAI2_SCK_B, FMC_D9/FMC_DA9, COMP1_OUT, LCD_B4, EVENTOUT	-
43	66	N11	76	T10	PE13	I/O	FT_h	-	TIM1_CH3, DFSDM1_CKIN5, SPI4_MISO, SAI2_FS_B, FMC_D10/FMC_DA10, COMP2_OUT, LCD_DE, EVENTOUT	-
-	-	F7	-	T12	VSS	S	-	-	-	-
-	-	-	-	K13	VDD	S	-	-	-	-
44	67	P11	77	U10	PE14	I/O	FT_h	-	TIM1_CH4, SPI4_MOSI, SAI2_MCLK_B, FMC_D11/FMC_DA11, LCD_CLK, EVENTOUT	-
45	68	R11	78	R11	PE15	I/O	FT_h	-	TIM1_BKIN, FMC_D12/FMC_DA12, TIM1_BKIN_COMP12/COMP_ TIM1_BKIN, LCD_R7, EVENTOUT	-
46	69	R12	79	P11	PB10	I/O	FT_f	-	TIM2_CH3, HRTIM_SCOUT, LPTIM2_IN1, I2C2_SCL, SPI2_SCK/I2S2_CK, DFSDM1_DATIN7, USART3_TX, QUADSPI_BK1_NCS, OTG_HS_ULPI_D3, ETH_MII_RX_ER, LCD_G4, EVENTOUT	-
47	70	R13	80	P12	PB11	I/O	FT_f	-	TIM2_CH4, HRTIM_SCIN, LPTIM2_ETR, I2C2_SDA, DFSDM1_CKIN7, USART3_RX, OTG_HS_ULPI_D4, ETH_MII_TX_EN/ETH_RMII_TX_ EN, LCD_G5, EVENTOUT	-
48	71	M10	81	U11	VCAP	S	-	-	-	-
49	-	K7	-	-	VSS	S	-	-	-	-
-	-	-	-	U12	VDDLDO	S	-	-	-	-
50	72	N10	82	L13	VDD	S	-	-	-	-
-	-	-	-	R12	PJ5	I/O	FT	-	LCD_R6, EVENTOUT	-

Table 7. STM32H750xB pin/ball definition (continued)

Pin/ball name					Pin name (function after reset)	Pin type	I/O structure	Notes	Alternate functions	Additional functions
LQFP100	LQFP144	UFBGA176+25	LQFP176	TFBGA240 +25						
-	-	M11	83	T11	PH6	I/O	FT	-	TIM12_CH1, I2C2_SMBA, SPI5_SCK, ETH_MII_RXD2, FMC_SDNE1, DCMI_D8, EVENTOUT	-
-	-	N12	84	U13	PH7	I/O	FT_fa	-	I2C3_SCL, SPI5_MISO, ETH_MII_RXD3, FMC_SDCKE1, DCMI_D9, EVENTOUT	-
-	-	M12	85	T13	PH8	I/O	FT_fha	-	TIM5_ETR, I2C3_SDA, FMC_D16, DCMI_HSYNC, LCD_R2, EVENTOUT	-
-	-	F8	-	-	VSS	S	-	-	-	-
-	-	-	-	M13	VDD	S	-	-	-	-
-	-	M13	86	R13	PH9	I/O	FT_h	-	TIM12_CH2, I2C3_SMBA, FMC_D17, DCMI_D0, LCD_R3, EVENTOUT	-
-	-	L13	87	P13	PH10	I/O	FT_h	-	TIM5_CH1, I2C4_SMBA, FMC_D18, DCMI_D1, LCD_R4, EVENTOUT	-
-	-	L12	88	P14	PH11	I/O	FT_fh	-	TIM5_CH2, I2C4_SCL, FMC_D19, DCMI_D2, LCD_R5, EVENTOUT	-
-	-	K12	89	R14	PH12	I/O	FT_fh	-	TIM5_CH3, I2C4_SDA, FMC_D20, DCMI_D3, LCD_R6, EVENTOUT	-
-	-	H12	90	N16	VSS	S	-	-	-	-
-	-	J12	91	P17	VDD	S	-	-	-	-
51	73	P12	92	T14	PB12	I/O	FT_u	-	TIM1_BKIN, I2C2_SMBA, SPI2_NSS/I2S2_WS, DFSDM1_DATIN1, USART3_CK, FDCAN2_RX, OTG_HS_ULPI_D5, ETH_MII_TXD0/ETH_RMII_TXD0, OTG_HS_ID, TIM1_BKIN_COMP12, UART5_RX, EVENTOUT	-
52	74	P13	93	U14	PB13	I/O	FT_u	-	TIM1_CH1N, LPTIM2_OUT, SPI2_SCK/I2S2_CK, DFSDM1_CKIN1, USART3_CTS/USART3_NSS, FDCAN2_TX, OTG_HS_ULPI_D6, ETH_MII_TXD1/ETH_RMII_TXD1, UART5_TX, EVENTOUT	OTG_HS_ VBUS

Table 7. STM32H750xB pin/ball definition (continued)

Pin/ball name					Pin name (function after reset)	Pin type	I/O structure	Notes	Alternate functions	Additional functions
LQFP100	LQFP144	UFBGA176+25	LQFP176	TFBGA240 +25						
53	75	R14	94	U15	PB14	I/O	FT_u	-	TIM1_CH2N, TIM12_CH1, TIM8_CH2N, USART1_TX, SPI2_MISO/I2S2_SDI, DFSDM1_DATIN2, USART3_RTS/USART3_DE, UART4_RTS/UART4_DE, SDMMC2_D0, OTG_HS_DM, EVENTOUT	-
54	76	R15	95	T15	PB15	I/O	FT_u	-	RTC_REFIN, TIM1_CH3N, TIM12_CH2, TIM8_CH3N, USART1_RX, SPI2_MOSI/I2S2_SDO, DFSDM1_CKIN2, UART4_CTS, SDMMC2_D1, OTG_HS_DP, EVENTOUT	-
55	77	P15	96	U16	PD8	I/O	FT_h	-	DFSDM1_CKIN3, SAI3_SCK_B, USART3_TX, SPDIFRX1_IN2, FMC_D13/FMC_DA13, EVENTOUT	-
56	78	P14	97	T17	PD9	I/O	FT_h	-	DFSDM1_DATIN3, SAI3_SD_B, USART3_RX, FDCAN2_RXFD_MODE, FMC_D14/FMC_DA14, EVENTOUT	-
57	79	N15	98	T16	PD10	I/O	FT_h	-	DFSDM1_CKOUT, SAI3_FS_B, USART3_CK, FDCAN2_TXFD_MODE, FMC_D15/FMC_DA15, LCD_B3, EVENTOUT	-
-	-	-	-	N12	VDD	S	-	-	-	-
-	-	F9	-	U17	VSS	S	-	-	-	-
58	80	N14	99	R15	PD11	I/O	FT_h	-	LPTIM2_IN2, I2C4_SMBA, USART3_CTS/USART3_NSS, QUADSPI_BK1_IO0, SAI2_SD_A, FMC_A16, EVENTOUT	-
59	81	N13	100	R16	PD12	I/O	FT_fh	-	LPTIM1_IN1, TIM4_CH1, LPTIM2_IN1, I2C4_SCL, USART3_RTS/USART3_DE, QUADSPI_BK1_IO1, SAI2_FS_A, FMC_A17, EVENTOUT	-
60	82	M15	101	R17	PD13	I/O	FT_fh	-	LPTIM1_OUT, TIM4_CH2, I2C4_SDA, QUADSPI_BK1_IO3, SAI2_SCK_A, FMC_A18, EVENTOUT	-

Table 7. STM32H750xB pin/ball definition (continued)

Pin/ball name					Pin name (function after reset)	Pin type	I/O structure	Notes	Alternate functions	Additional functions
LQFP100	LQFP144	UFBGA176+25	LQFP176	TFBGA240 +25						
-	83	K8	102	-	VSS	S	-	-	-	-
-	84	J13	103	N11	VDD	S	-	-	-	-
61	85	M14	104	P16	PD14	I/O	FT_h	-	TIM4_CH3, SAI3_MCLK_B, UART8_CTS, FMC_D0/FMC_DA0, EVENTOUT	-
62	86	L14	105	P15	PD15	I/O	FT_h	-	TIM4_CH4, SAI3_MCLK_A, UART8_RTS/UART8_DE, FMC_D1/FMC_DA1, EVENTOUT	-
-	-	-	-	N15	PJ6	I/O	FT	-	TIM8_CH2, LCD_R7, EVENTOUT	-
-	-	-	-	N14	PJ7	I/O	FT	-	TRGIN, TIM8_CH2N, LCD_G0, EVENTOUT	-
-	-	-	-	N10	VDD	S	-	-	-	-
-	-	F10	-	R8	VSS	S	-	-	-	-
-	-	-	-	N13	PJ8	I/O	FT	-	TIM1_CH3N, TIM8_CH1, UART8_TX, LCD_G1, EVENTOUT	-
-	-	-	-	M14	PJ9	I/O	FT	-	TIM1_CH3, TIM8_CH1N, UART8_RX, LCD_G2, EVENTOUT	-
-	-	-	-	L14	PJ10	I/O	FT	-	TIM1_CH2N, TIM8_CH2, SPI5_MOSI, LCD_G3, EVENTOUT	-
-	-	-	-	K14	PJ11	I/O	FT	-	TIM1_CH2, TIM8_CH2N, SPI5_MISO, LCD_G4, EVENTOUT	-
-	-	-	-	N8	VDD	S	-	-	-	-
-	-	G6	-	U1	VSS	S	-	-	-	-
-	-	-	-	N17 <sup>(2)</sup>	NC	-	-	-	-	-
-	-	-	-	M16 <sup>(2)</sup>	NC	-	-	-	-	-
-	-	-	-	M17 <sup>(2)</sup>	NC	-	-	-	-	-
-	-	-	-	K15	VSS	S	-	-	-	-
-	-	-	-	L16 <sup>(2)</sup>	NC	-	-	-	-	-
-	-	-	-	L17 <sup>(2)</sup>	NC	-	-	-	-	-
-	-	-	-	K16 <sup>(2)</sup>	NC	-	-	-	-	-
-	-	-	-	K17 <sup>(2)</sup>	NC	-	-	-	-	-
-	-	-	-	L15	VSS	S	-	-	-	-
-	-	-	-	J14	PK0	I/O	FT	-	TIM1_CH1N, TIM8_CH3, SPI5_SCK, LCD_G5, EVENTOUT	-

Table 7. STM32H750xB pin/ball definition (continued)

Pin/ball name					Pin name (function after reset)	Pin type	I/O structure	Notes	Alternate functions	Additional functions
LQFP100	LQFP144	UFBGA176+25	LQFP176	TFBGA240 +25						
-	-	-	-	J15	PK1	I/O	FT	-	TIM1_CH1, TIM8_CH3N, SPI5_NSS, LCD_G6, EVENTOUT	-
-	-	-	-	H17	PK2	I/O	FT	-	TIM1_BKIN, TIM8_BKIN, TIM8_BKIN_COMP12, TIM1_BKIN_COMP12, LCD_G7, EVENTOUT	-
-	87	L15	106	H16	PG2	I/O	FT_h	-	TIM8_BKIN, TIM8_BKIN_COMP12, FMC_A12, EVENTOUT	-
-	88	K15	107	H15	PG3	I/O	FT_h	-	TIM8_BKIN2, TIM8_BKIN2_COMP12, FMC_A13, EVENTOUT	-
-	-	G7	-	-	VSS	S	-	-	-	-
-	-	-	-	N7	VDD	S	-	-	-	-
-	89	K14	108	H14	PG4	I/O	FT_h	-	TIM1_BKIN2, TIM1_BKIN2_COMP12, FMC_A14/FMC_BA0, EVENTOUT	-
-	90	K13	109	G14	PG5	I/O	FT_h	-	TIM1_ETR, FMC_A15/FMC_BA1, EVENTOUT	-
-	91	J15	110	G15	PG6	I/O	FT_h	-	TIM17_BKIN, HRTIM_CHE1, QUADSPI_BK1_NCS, FMC_NE3, DCMI_D12, LCD_R7, EVENTOUT	-
-	92	J14	111	F16	PG7	I/O	FT_h	-	HRTIM_CHE2, SAI1_MCLK_A, USART6_CK, FMC_INT, DCMI_D13, LCD_CLK, EVENTOUT	-
-	93	H14	112	F15	PG8	I/O	FT_h	-	TIM8_ETR, SPI6_NSS, USART6_RTS/USART6_DE, SPDIFRX1_IN3, ETH_PPS_OUT, FMC_SDCLK, LCD_G7, EVENTOUT	-
-	94	G12	113	G16	VSS	S	-	-	-	-
-	-	-	-	G17	VDD50USB	S	-	-	-	-
-	95	H13	114	F17	VDD33USB	S	-	-	-	-
-	-	-	-	M5	VDD	S	-	-	-	-

Table 7. STM32H750xB pin/ball definition (continued)

Pin/ball name					Pin name (function after reset)	Pin type	I/O structure	Notes	Alternate functions	Additional functions
LQFP100	LQFP144	UFBGA176+25	LQFP176	TFBGA240 +25						
63	96	H15	115	F14	PC6	I/O	FT_h	-	HRTIM_CHA1, TIM3_CH1, TIM8_CH1, DFSDM1_CKIN3, I2S2_MCK, USART6_TX, SDMMC1_D0DIR, FMC_NWAIT, SDMMC2_D6, SDMMC1_D6, DCMI_D0, LCD_HSYNC, EVENTOUT	SWPMI_IO
64	97	G15	116	F13	PC7	I/O	FT_h	-	TRGIO, HRTIM_CHA2, TIM3_CH2, TIM8_CH2, DFSDM1_DATIN3, I2S3_MCK, USART6_RX, SDMMC1_D123DIR, FMC_NE1, SDMMC2_D7, SWPMI_TX, SDMMC1_D7, DCMI_D1, LCD_G6, EVENTOUT	-
65	98	G14	117	E13	PC8	I/O	FT_h	-	TRACED1, HRTIM_CHB1, TIM3_CH3, TIM8_CH3, USART6_CK, UART5_RTS/UART5_DE, FMC_NE2/FMC_NCE, SWPMI_RX, SDMMC1_D0, DCMI_D2, EVENTOUT	-
66	99	F14	118	E14	PC9	I/O	FT_fh	-	MCO2, TIM3_CH4, TIM8_CH4, I2C3_SDA, I2S_CKIN, UART5_CTS, QUADSPI_BK1_IO0, LCD_G3, SWPMI_SUSPEND, SDMMC1_D1, DCMI_D3, LCD_B2, EVENTOUT	-
-	-	G8	-	-	VSS	S	-	-		-
-	-	-	-	L5	VDD	S	-	-		-
67	100	F15	119	E15	PA8	I/O	FT_fha	-	MCO1, TIM1_CH1, HRTIM_CHB2, TIM8_BKIN2, I2C3_SCL, USART1_CK, OTG_FS_SOF, UART7_RX, TIM8_BKIN2_COMP12, LCD_B3, LCD_R6, EVENTOUT	-
68	101	E15	120	D15	PA9	I/O	FT_u	-	TIM1_CH2, HRTIM_CHC1, LPUART1_TX, I2C3_SMBA, SPI2_SCK/I2S2_CK, USART1_TX, FDCAN1_RXFD_MODE, DCMI_D0, LCD_R5, EVENTOUT	OTG_FS_VBUS

Table 7. STM32H750xB pin/ball definition (continued)

Pin/ball name					Pin name (function after reset)	Pin type	I/O structure	Notes	Alternate functions	Additional functions
LQFP100	LQFP144	UFBGA176+25	LQFP176	TFBGA240 +25						
69	102	D15	121	D14	PA10	I/O	FT_u	-	TIM1_CH3, HRTIM_CHC2, LPUART1_RX, USART1_RX, FDCAN1_TXFD_MODE, OTG_FS_ID, MDIOS_MDIO, LCD_B4, DCMI_D1, LCD_B1, EVENTOUT	-
70	103	C15	122	E17	PA11	I/O	FT_u	-	TIM1_CH4, HRTIM_CHD1, LPUART1_CTS, SPI2_NSS/I2S2_WS, UART4_RX, USART1_CTS/USART1_NSS, FDCAN1_RX, OTG_FS_DM, LCD_R4, EVENTOUT	-
71	104	B15	123	E16	PA12	I/O	FT_u	-	TIM1_ETR, HRTIM_CHD2, LPUART1_RTS/LPUART1_DE, SPI2_SCK/I2S2_CK, UART4_TX, USART1_RTS/USART1_DE, SAI2_FS_B, FDCAN1_TX, OTG_FS_DP, LCD_R5, EVENTOUT	-
72	105	A15	124	C15	PA13 (JTMS/SWDIO)	I/O	FT	-	JTMS-SWDIO, EVENTOUT	-
73	106	F13	125	D17	VCAP	S	-	-	-	-
74	107	F12	126	-	VSS	S	-	-	-	-
-	-	-	-	C17	VDDLDO		-	-	-	-
75	108	G13	127	K5	VDD	S	-	-	-	-
-	-	E12	128	D16	PH13	I/O	FT_h	-	TIM8_CH1N, UART4_TX, FDCAN1_TX, FMC_D21, LCD_G2, EVENTOUT	-
-	-	E13	129	B17	PH14	I/O	FT_h	-	TIM8_CH2N, UART4_RX, FDCAN1_RX, FMC_D22, DCMI_D4, LCD_G3, EVENTOUT	-
-	-	D13	130	B16	PH15	I/O	FT_h	-	TIM8_CH3N, FDCAN1_TXFD_MODE, FMC_D23, DCMI_D11, LCD_G4, EVENTOUT	-
-	-	E14	131	A16	PI0	I/O	FT_h	-	TIM5_CH4, SPI2_NSS/I2S2_WS, FDCAN1_RXFD_MODE, FMC_D24, DCMI_D13, LCD_G5, EVENTOUT	-
-	-	G9	-	-	VSS	S	-	-	-	-



Table 7. STM32H750xB pin/ball definition (continued)

Pin/ball name					Pin name (function after reset)	Pin type	I/O structure	Notes	Alternate functions	Additional functions
LQFP100	LQFP144	UFBGA176+25	LQFP176	TFBGA240 +25						
-	-	D14	132	A15	PI1	I/O	FT_h	-	TIM8_BKIN2, SPI2_SCK/I2S2_CK, TIM8_BKIN2_COMP12, FMC_D25, DCMI_D8, LCD_G6, EVENTOUT	-
-	-	C14	133	B15	PI2	I/O	FT_h	-	TIM8_CH4, SPI2_MISO/I2S2_SDI, FMC_D26, DCMI_D9, LCD_G7, EVENTOUT	-
-	-	C13	134	C14	PI3	I/O	FT_h	-	TIM8_ETR, SPI2_MOSI/I2S2_SDO, FMC_D27, DCMI_D10, EVENTOUT	-
-	-	D9	135	-	VSS	S	-	-	-	-
-	-	C9	136	-	VDD	S	-	-	-	-
76	109	A14	137	B14	PA14 (JTCK/SWCLK)	I/O	FT	-	JTCK-SWCLK, EVENTOUT	-
77	110	A13	138	A14	PA15 (JTDI)	I/O	FT	-	JTDI, TIM2_CH1/TIM2_ETR, HRTIM_FLT1, CEC, SPI1_NSS/I2S1_WS, SPI3_NSS/I2S3_WS, SPI6_NSS, UART4_RTS/UART4_DE, UART7_TX, EVENTOUT	-
78	111	B14	139	A13	PC10	I/O	FT_ha	-	HRTIM_EEV1, DFSDM1_CKIN5, SPI3_SCK/I2S3_CK, USART3_TX, UART4_TX, QUADSPI_BK1_IO1, SDMMC1_D2, DCMI_D8, LCD_R2, EVENTOUT	-
79	112	B13	140	B13	PC11	I/O	FT_h	-	HRTIM_FLT2, DFSDM1_DATIN5, SPI3_MISO/I2S3_SDI, USART3_RX, UART4_RX, QUADSPI_BK2_NCS, SDMMC1_D3, DCMI_D4, EVENTOUT	-
80	113	A12	141	C12	PC12	I/O	FT_h	-	TRACED3, HRTIM_EEV2, SPI3_MOSI/I2S3_SDO, USART3_CK, UART5_TX, SDMMC1_CK, DCMI_D9, EVENTOUT	-
-	-	G10	-	-	VSS	S	-	-	-	-
81	114	B12	142	D13	PD0	I/O	FT_h	-	DFSDM1_CKIN6, SAI3_SCK_A, UART4_RX, FDCAN1_RX, FMC_D2/FMC_DA2, EVENTOUT	-

Table 7. STM32H750xB pin/ball definition (continued)

Pin/ball name					Pin name (function after reset)	Pin type	I/O structure	Notes	Alternate functions	Additional functions
LQFP100	LQFP144	UFBGA176+25	LQFP176	TFBGA240 +25						
82	115	C12	143	E12	PD1	I/O	FT_h	-	DFSDM1_DATIN6, SAI3_SD_A, UART4_TX, FDCAN1_TX, FMC_D3/FMC_DA3, EVENTOUT	-
83	116	D12	144	D12	PD2	I/O	FT_h	-	TRACED2, TIM3_ETR, UART5_RX, SDMMC1_CMD, DCMI_D11, EVENTOUT	-
84	117	D11	145	B12	PD3	I/O	FT_h	-	DFSDM1_CKOUT, SPI2_SCK/I2S2_CK, USART2_CTS/USART2_NSS, FMC_CLK, DCMI_D5, LCD_G7, EVENTOUT	-
85	118	D10	146	A12	PD4	I/O	FT_h	-	HRTIM_FLT3, SAI3_FS_A, USART2_RTS/USART2_DE, FDCAN1_RXFD_MODE, FMC_NOE, EVENTOUT	-
86	119	C11	147	A11	PD5	I/O	FT_h	-	HRTIM_EEV3, USART2_TX, FDCAN1_TXFD_MODE, FMC_NWE, EVENTOUT	-
-	120	D8	148	-	VSS	S	-	-	-	-
-	121	C8	149	-	VDD	S	-	-	-	-
87	122	B11	150	B11	PD6	I/O	FT_h	-	SAI1_D1, DFSDM1_CKIN4, DFSDM1_DATIN1, SPI3_MOSI/I2S3_SDO, SAI1_SD_A, USART2_RX, SAI4_SD_A, FDCAN2_RXFD_MODE, SAI4_D1, SDMMC2_CK, FMC_NWAIT, DCMI_D10, LCD_B2, EVENTOUT	-
88	123	A11	151	C11	PD7	I/O	FT_h	-	DFSDM1_DATIN4, SPI1_MOSI/I2S1_SDO, DFSDM1_CKIN1, USART2_CK, SPDIFRX1_IN1, SDMMC2_CMD, FMC_NE1, EVENTOUT	-
-	-	-	-	D11	PJ12	I/O	FT	-	TRGOUT, LCD_G3, LCD_B0, EVENTOUT	-
-	-	-	-	E10	PJ13	I/O	FT	-	LCD_B4, LCD_B1, EVENTOUT	-
-	-	-	-	D10	PJ14	I/O	FT	-	LCD_B2, EVENTOUT	-
-	-	-	-	B10	PJ15	I/O	FT	-	LCD_B3, EVENTOUT	-
-	-	H6	-	-	VSS	S	-	-	-	-
-	-	-	-	-	VDD	S	-	-	-	-

Table 7. STM32H750xB pin/ball definition (continued)

Pin/ball name					Pin name (function after reset)	Pin type	I/O structure	Notes	Alternate functions	Additional functions
LQFP100	LQFP144	UFBGA176+25	LQFP176	TFBGA240 +25						
-	124	C10	152	A10	PG9	I/O	FT_h	-	SPI1_MISO/I2S1_SDI, USART6_RX, SPDIFRX1_IN4, QUADSPI_BK2_IO2, SAI2_FS_B, FMC_NE2/FMC_NCE, DCMI_VSYNC, EVENTOUT	-
-	125	B10	153	A9	PG10	I/O	FT_h	-	HRTIM_FLT5, SPI1_NSS/I2S1_WS, LCD_G3, SAI2_SD_B, FMC_NE3, DCMI_D2, LCD_B2, EVENTOUT	-
-	126	B9	154	B9	PG11	I/O	FT_h	-	LPTIM1_IN2, HRTIM_EEV4, SPI1_SCK/I2S1_CK, SPDIFRX1_IN1, SDMMC2_D2, ETH_MII_TX_EN/ETH_RMII_TX_ EN, DCMI_D3, LCD_B3, EVENTOUT	-
-	127	B8	155	C9	PG12	I/O	FT_h	-	LPTIM1_IN1, HRTIM_EEV5, SPI6_MISO, USART6_RTS/USART6_DE, SPDIFRX1_IN2, LCD_B4, ETH_MII_TXD1/ETH_RMII_TXD1, FMC_NE4, LCD_B1, EVENTOUT	-
-	128	A8	156	D9	PG13	I/O	FT_h	-	TRACED0, LPTIM1_OUT, HRTIM_EEV10, SPI6_SCK, USART6_CTS/USART6_NSS, ETH_MII_TXD0/ETH_RMII_TXD0, FMC_A24, LCD_R0, EVENTOUT	-
-	129	A7	157	D8	PG14	I/O	FT_h	-	TRACED1, LPTIM1_ETR, SPI6_MOSI, USART6_TX, QUADSPI_BK2_IO3, ETH_MII_TXD1/ETH_RMII_TXD1, FMC_A25, LCD_B0, EVENTOUT	-
-	130	D7	158	-	VSS	S	-	-	-	-
-	131	C7	159	-	VDD	S	-	-	-	-
-	-	-	-	C8	PK3	I/O	FT	-	LCD_B4, EVENTOUT	-
-	-	-	-	B8	PK4	I/O	FT	-	LCD_B5, EVENTOUT	-
-	-	-	-	A8	PK5	I/O	FT	-	LCD_B6, EVENTOUT	-
-	-	-	-	C7	PK6	I/O	FT	-	LCD_B7, EVENTOUT	-
-	-	-	-	D7	PK7	I/O	FT	-	LCD_DE, EVENTOUT	-
-	-	H7	-	-	VSS	S	-	-	-	-
-	132	B7	160	D6	PG15	I/O	FT_h	-	USART6_CTS/USART6_NSS, FMC_SDNCAS, DCMI_D13, EVENTOUT	-

Table 7. STM32H750xB pin/ball definition (continued)

Pin/ball name					Pin name (function after reset)	Pin type	I/O structure	Notes	Alternate functions	Additional functions
LQFP100	LQFP144	UFBGA176+25	LQFP176	TFBGA240 +25						
89	133	A10	161	C6	PB3 (JTDO/TRACES WO)	I/O	FT	-	JTDO/TRACESWO, TIM2_CH2, HRTIM_FLT4, SPI1_SCK/I2S1_CK, SPI3_SCK/I2S3_CK, SPI6_SCK, SDMMC2_D2, CRS_SYNC, UART7_RX, EVENTOUT	-
90	134	A9	162	B7	PB4(NJTRST)	I/O	FT	-	NJTRST, TIM16_BKIN, TIM3_CH1, HRTIM_EEV6, SPI1_MISO/I2S1_SDI, SPI3_MISO/I2S3_SDI, SPI2_NSS/I2S2_WS, SPI6_MISO, SDMMC2_D3, UART7_TX, EVENTOUT	-
91	135	A6	163	A5	PB5	I/O	FT	-	TIM17_BKIN, TIM3_CH2, HRTIM_EEV7, I2C1_SMBA, SPI1_MOSI/I2S1_SDO, I2C4_SMBA, SPI3_MOSI/I2S3_SDO, SPI6_MOSI, FDCAN2_RX, OTG_HS_ULPI_D7, ETH_PPS_OUT, FMC_SDCKE1, DCMI_D10, UART5_RX, EVENTOUT	-
-	-	H8	-	-	VSS	S	-	-	-	-
92	136	B6	164	B5	PB6	I/O	FT_f	-	TIM16_CH1N, TIM4_CH1, HRTIM_EEV8, I2C1_SCL, CEC, I2C4_SCL, USART1_TX, LPUART1_TX, FDCAN2_TX, QUADSPI_BK1_NCS, DFSDM1_DATIN5, FMC_SDNE1, DCMI_D5, UART5_TX, EVENTOUT	-
93	137	B5	165	C5	PB7	I/O	FT_fa	-	TIM17_CH1N, TIM4_CH2, HRTIM_EEV9, I2C1_SDA, I2C4_SDA, USART1_RX, LPUART1_RX, FDCAN2_TXFD_MODE, DFSDM1_CKIN5, FMC_NL, DCMI_VSYNC, EVENTOUT	PVD_IN
94	138	D6	166	E8	BOOT0	I	B	-	-	VPP

Table 7. STM32H750xB pin/ball definition (continued)

Pin/ball name					Pin name (function after reset)	Pin type	I/O structure	Notes	Alternate functions	Additional functions
LQFP100	LQFP144	UFBGA176+25	LQFP176	TFBGA240 +25						
95	139	A5	167	D5	PB8	I/O	FT_fh	-	TIM16_CH1, TIM4_CH3, DFSDM1_CKIN7, I2C1_SCL, I2C4_SCL, SDMMC1_CKIN, UART4_RX, FDCAN1_RX, SDMMC2_D4, ETH_MII_TXD3, SDMMC1_D4, DCMI_D6, LCD_B6, EVENTOUT	-
96	140	B4	168	D4	PB9	I/O	FT_fh	-	TIM17_CH1, TIM4_CH4, DFSDM1_DATIN7, I2C1_SDA, SPI2_NSS/I2S2_WS, I2C4_SDA, SDMMC1_CDIR, UART4_TX, FDCAN1_TX, SDMMC2_D5, I2C4_SMBA, SDMMC1_D5, DCMI_D7, LCD_B7, EVENTOUT	-
97	141	A4	169	C4	PE0	I/O	FT_h	-	LPTIM1_ETR, TIM4_ETR, HRTIM_SCIN, LPTIM2_ETR, UART8_RX, FDCAN1_RXFD_MODE, SAI2_MCLK_A, FMC_NBL0, DCMI_D2, EVENTOUT	-
98	142	A3	170	B4	PE1	I/O	FT_h	-	LPTIM1_IN2, HRTIM_SCOUT, UART8_TX, FDCAN1_TXFD_MODE, FMC_NBL1, DCMI_D3, EVENTOUT	-
-	-	-	-	A7	VCAP	S	-	-	-	-
99	-	D5	-	-	VSS	S	-	-	-	-
-	143	C6	171	E7	PDR_ON	I	FT	-	-	-
-	-	-	-	A6	VDDLDO	S	-	-	-	-
100	144	C5	172	-	VDD	S	-	-	-	-
-	-	D4	173	A4	PI4	I/O	FT_h	-	TIM8_BKIN, SAI2_MCLK_A, TIM8_BKIN_COMP12, FMC_NBL2, DCMI_D5, LCD_B4, EVENTOUT	-
-	-	C4	174	A3	PI5	I/O	FT_h	-	TIM8_CH1, SAI2_SCK_A, FMC_NBL3, DCMI_VSYNCR, LCD_B5, EVENTOUT	-
-	-	C3	175	A2	PI6	I/O	FT_h	-	TIM8_CH2, SAI2_SD_A, FMC_D28, DCMI_D6, LCD_B6, EVENTOUT	-
-	-	C2	176	B3	PI7	I/O	FT_h	-	TIM8_CH3, SAI2_FS_A, FMC_D29, DCMI_D7, LCD_B7, EVENTOUT	-

Table 7. STM32H750xB pin/ball definition (continued)

Pin/ball name					Pin name (function after reset)	Pin type	I/O structure	Notes	Alternate functions	Additional functions
LQFP100	LQFP144	UFBGA176+25	LQFP176	TFBGA240 +25						
-	-	H9	-	-	VSS	S	-	-	-	-
-	-	K9	-	-	VSS	S	-	-	-	-
-	-	K10	-	M15	VSS	S	-	-	-	-

1. When this pin/ball was previously configured as an oscillator, the oscillator function is kept during and after a reset. This is valid for all resets except for power-on reset.
2. This ball should remain floating.
3. This ball should not remain floating. It can be connected to VSS or VDD. It is reserved for future use.
4. This ball should be connected to  $V_{SS}$ .
5. Pxy\_C and Pxy pins/balls are two separate pads (analog switch open). The analog switch is configured through a SYSCFG register. Refer to the product reference manual for a detailed description of the switch configuration bits.
6. There is a direct path between Pxy\_C and Pxy pins/balls, through an analog switch. Pxy alternate functions are available on Pxy\_C when the analog switch is closed. The analog switch is configured through a SYSCFG register. Refer to the product reference manual for a detailed description of the switch configuration bits.

**Table 8. Port A alternate functions**

Port	AF0	AF1	AF2	AF3	AF4	AF5	AF6	AF7	AF8	AF9	AF10	AF11	AF12	AF13	AF14	AF15
	SYS	TIM1/2/16/ 17/LPTIM1/ HRTIM1	SAI1/TIM3/ 4/5/12/ HRTIM1	LPUART/ TIM8/ LPTIM2/3/4/ 5/HRTIM1/ DFSDM1	I2C1/2/3/4/ USART1/ TIM15/ LPTIM2/ DFSDM1/ CEC		SPI1/2/3/4/ 5/6/CEC	SPI2/3/SAI1/ 3/I2C4/ UART4/ DFSDM1	SPI2/3/6/ USART1/2/ 3/6/UART7/ SDMMC1	SPI6/SAI2/ 4/UART4/5/ 8/LPUART/ SDMMC1/ SPDIFRX1	SAI4/ FDCAN1/2/ TIM13/14/ QUADSPI/ FMC/ SDMMC2/ OTG1_HS/ OTG2_FS/ LCD	SAI2/4/ TIM8/ QUADSPI/ SDMMC2/ OTG1_HS/ OTG2_FS/ LCD	I2C4/ UART7/ SWPMI1/ TIM1/8/ DFSDM1/ SDMMC2/ MDIOS/ ETH	TIM1/8/FMC /SDMMC1/ MDIOS/ OTG1_FS/ LCD	TIM1/DCMI /LCD/ COMP	UART5/ LCD
PA0	-	TIM2_CH1/ TIM2_ETR	TIM5_CH1	TIM8_ETR	TIM15_BKIN	-	-	USART2_ CTS/ USART2_ NSS	UART4_TX	SDMMC2_ CMD	SAI2_SD_B	ETH_MII_ CRS	-	-	-	EVENT- OUT
PA1	-	TIM2_CH2	TIM5_CH2	LPTIM3_ OUT	TIM15_ CH1N	-	-	USART2_ RTS/ USART2_ DE	UART4_RX	QUADSPI_ BK1_IO3	SAI2_MCLK_ _B	ETH_MII_ RX_CLK/ ETH_RMII_ REF_CLK	-	-	LCD_R2	EVENT- OUT
PA2	-	TIM2_CH3	TIM5_CH3	LPTIM4_ OUT	TIM15_CH1	-	-	USART2_ TX	SAI2_SCK_ _B	-	-	ETH_MDIO	MDIOS_ MDIO	-	LCD_R1	EVENT- OUT
PA3	-	TIM2_CH4	TIM5_CH4	LPTIM5_ OUT	TIM15_CH2	-	-	USART2_ RX	-	LCD_B2	OTG_HS_ ULPI_D0	ETH_MII_ COL	-	-	LCD_B5	EVENT- OUT
PA4	D1 PWREN	-	TIM5_ETR	-	-	SPI1_NSS/ I2S1_WS	SPI3_NSS/ I2S3_WS	USART2_ CK	SPI6_NSS	-	-	-	OTG_HS_ SOF	DCML_ HSYNC	LCD_ VSYNC	EVENT- OUT
PA5	D2 PWREN	TIM2_CH1/ TIM2_ETR	-	TIM8_ CH1N	-	SPI1_SCK /I2S1_CK	-	-	SPI6_SCK	-	OTG_HS_ ULPI_CK	-	-	-	LCD_R4	EVENT- OUT
PA6	-	TIM1_BKIN	TIM3_CH1	TIM8_BKIN	-	SPI1_MISO /I2S1_SDI	-	-	SPI6_MISO	TIM13_ CH1	TIM8_BKIN _COMP12	MDIOS_ MDC	TIM1_BKIN _COMP12	DCMI_PIX CLK	LCD_G2	EVENT- OUT
PA7	-	TIM1_CH1N	TIM3_CH2	TIM8_CH1 N	-	SPI1_MOSI /I2S1_SDO	-	-	SPI6_MOSI	TIM14_ CH1	-	ETH_MII_ RX_DV/ ETH_RMII_ CRS_DV	FMC_SDN WE	-	-	EVENT- OUT
PA8	MCO1	TIM1_CH1	HRTIM_CH B2	TIM8_BKIN 2	I2C3_SCL	-	-	USART1_ CK	-	-	OTG_FS_ SOF	UART7_RX	TIM8_BKIN 2_COMP12	LCD_B3	LCD_R6	EVENT- OUT
PA9	-	TIM1_CH2	HRTIM_CH C1	LPUART1_ TX	I2C3_SMBA	SPI2_SCK/ I2S2_CK	-	USART1_ TX	-	FDCAN1_ RXFD_ MODE	-	-	-	DCMI_D0	LCD_R5	EVENT- OUT
PA10	-	TIM1_CH3	HRTIM_CH C2	LPUART1_ RX	-	-	-	USART1_ RX	-	FDCAN1_ TXFD_ MODE	OTG_FS_ID	MDIOS_ MDIO	LCD_B4	DCMI_D1	LCD_B1	EVENT- OUT
PA11	-	TIM1_CH4	HRTIM_CH D1	LPUART1_ CTS	-	SPI2_NSS /I2S2_WS	UART4_RX	USART1_ CTS/ USART1_ NSS	-	FDCAN1_ RX	OTG_FS_ DM	-	-	-	LCD_R4	EVENT- OUT
PA12	-	TIM1_ETR	HRTIM_CH D2	LPUART1_ RTS/ LPUART1_ DE	-	SPI2_SCK/ I2S2_CK	UART4_TX	USART1_ RTS/ USART1_ DE	SAI2_FS_B	FDCAN1_ TX	OTG_FS_ DP	-	-	-	LCD_R5	EVENT- OUT



Table 8. Port A alternate functions (continued)

Port	AF0	AF1	AF2	AF3	AF4	AF5	AF6	AF7	AF8	AF9	AF10	AF11	AF12	AF13	AF14	AF15
	SYS	TIM1/2/16/ 17/LPTIM1/ HRTIM1	SAI1/TIM3/ 4/5/12/ HRTIM1	LPUART/ TIM8/ LPTIM2/3/4/ 5/HRTIM1/ DFSDM1	I2C1/2/3/4/ USART1/ TIM15/ LPTIM2/ DFSDM1/ CEC	SPI1/2/3/4/ 5/6/CEC	SPI2/3/SAI1/ 3/I2C4/ UART4/ DFSDM1	SPI2/3/6/ USART1/2/ 3/6/UART7/ SDMMC1	SPI6/SAI2/ 4/UART4/5/ 8/LPUART/ SDMMC1/ SPDIFRX1	SAI4/ FDCAN1/2/ TIM13/14/ QUADSPI/ FMC/ SDMMC2/ LCD/ SPDIFRX1	SAI2/4/ TIM8/ QUADSPI/ SDMMC2/ OTG1_HS/ OTG2_FS/ LCD	I2C4/ UART7/ SWPMI1/ TIM1/8/ DFSDM1/ SDMMC2/ MDIOS/ ETH	TIM1/8/FMC /SDMMC1/ MDIOS/ OTG1_FS/ LCD	TIM1/DCMI /LCD/ COMP	UART5/ LCD	SYS
Port A	PA13	JTMS-SWDIO	-	-	-	-	-	-	-	-	-	-	-	-	-	EVENT-OUT
	PA14	JTCK-SWCLK	-	-	-	-	-	-	-	-	-	-	-	-	-	EVENT-OUT
	PA15	JTDI	TIM2_CH1/ TIM2_ETR	HRTIM_FLT1	-	CEC	SPI1_NSS/ I2S1_WS	SPI3_NSS/ I2S3_WS	SPI6_NSS	UART4_ RTS/ UART4_ DE	-	-	UART7_TX	-	-	-

Table 9. Port B alternate functions

Port	AF0	AF1	AF2	AF3	AF4	AF5	AF6	AF7	AF8	AF9	AF10	AF11	AF12	AF13	AF14	AF15	
	SYS	TIM1/2/16/ 17/LPTIM1/ HRTIM1	SAI1/TIM3/ 4/5/12/ HRTIM1	LPUART/ TIM8/ LPTIM2/3/4/ 5/HRTIM1/ DFSDM1	I2C1/2/3/4/ USART1/ TIM15/ LPTIM2/ DFSDM1/ CEC	SPI1/2/3/4/5/ 6/CEC	SPI2/3/SAI1/ 3/I2C4/ UART4/ DFSDM1	SPI2/3/6/ USART1/2/3 /6/UART7/S DMMC1	SPI6/SAI2/ 4/UART4/5/ 8/LPUART/ SDMMC1/ SPDIFRX1	SAI4/ FDCAN1/2/ TIM13/14/ QUADSPI/ FMC/ SDMMC2/ LCD/ SPDIFRX1	SAI2/4/ TIM8/ QUADSPI/ SDMMC2/ OTG1_HS/ OTG2_FS/ LCD	I2C4/ UART7/ SWPMI1/ TIM1/8/ DFSDM1/ SDMMC2/ MDIOS/ ETH	TIM1/8/FMC /SDMMC1/ MDIOS/ OTG1_FS/ LCD	TIM1/ DCMI/LCD /COMP	UART5/ LCD	SYS	
Port B	PB0	-	TIM1_CH2N	TIM3_CH3	TIM8_CH2N	-	-	DFSDM1_CKOUT	-	UART4_CTS	LCD_R3	OTG_HS_ULPI_D1	ETH_MII_RXD2	-	-	LCD_G1	EVENT-OUT
	PB1	-	TIM1_CH3N	TIM3_CH4	TIM8_CH3N	-	-	DFSDM1_DATIN1	-	-	LCD_R6	OTG_HS_ULPI_D2	ETH_MII_RXD3	-	-	LCD_G0	EVENT-OUT
	PB2	RTC_OUT	-	SAI1_D1	-	DFSDM1_CKIN1	-	SAI1_SD_A	SPI3_MOSI/I2S3_SDO	SAI4_SD_A	QUADSPI_CLK	SAI4_D1	-	-	-	-	EVENT-OUT
	PB3	JTDO/TRACESWO	TIM2_CH2	HRTIM_FLT4	-	-	SPI1_SCK/ I2S1_CK	SPI3_SCK/ I2S3_CK	-	SPI6_SCK	SDMMC2_D2	CRS_SYNC	UART7_RX	-	-	-	EVENT-OUT
	PB4	NJTRST	TIM16_BKIN	TIM3_CH1	HRTIM_EEV6	-	SPI1_MISO/ I2S1_SDI	SPI3_MISO/ I2S3_SDI	SPI2_NSS/ I2S2_WS	SPI6_MISO	SDMMC2_D3	-	UART7_TX	-	-	-	EVENT-OUT
	PB5	-	TIM17_BKIN	TIM3_CH2	HRTIM_EEV7	I2C1_SMBA	SPI1_MOSI/ I2S1_SDO	I2C4_SMBA	SPI3_MOSI/ I2S3_SDO	SPI6_MOSI	FDCAN2_RX	OTG_HS_ULPI_D7	ETH_PPS_OUT	FMC_SDCKE1	DCMI_D10	UART5_RX	EVENT-OUT
	PB6	-	TIM16_CH1N	TIM4_CH1	HRTIM_EEV8	I2C1_SCL	CEC	I2C4_SCL	USART1_TX	LPUART1_TX	FDCAN2_TX	QUADSPI_BK1_NCS	DFSDM1_DATIN5	FMC_SDNE1	DCMI_D5	UART5_TX	EVENT-OUT
	PB7	-	TIM17_CH1N	TIM4_CH2	HRTIM_EEV9	I2C1_SDA	-	I2C4_SDA	USART1_RX	LPUART1_RX	FDCAN2_TXFD_MODE	-	DFSDM1_CKIN5	FMC_NL	DCMI_VSYNC	-	EVENT-OUT





**Table 9. Port B alternate functions (continued)**

Port	AF0	AF1	AF2	AF3	AF4	AF5	AF6	AF7	AF8	AF9	AF10	AF11	AF12	AF13	AF14	AF15	
	SYS	TIM1/2/16/ 17/LPTIM1/ HRTIM1	SAI1/TIM3/ 4/5/12/ HRTIM1	LPUART/ TIM8/ LPTIM2/3/4 5/HRTIM1/ DFSDM1	I2C1/2/3/4/ USART1/ TIM15/ LPTIM2/ DFSDM1/ CEC	SPI1/2/3/4/5/ 6/CEC	SPI2/3/SAI1 3/I2C4/ UART4/ DFSDM1	SPI2/3/6/ USART1/2/3 6/UART7/S DMMC1	SPI6/SAI2/ 4/UART4/5/ 8/LPUART/ SDMMC1/ SPDIFRX1	SAI4/ FDCAN1/2/ TIM13/14/ QUADSPI/ FMC/ SDMMC2/ LCD/ SPDIFRX1	SAI2/4/ TIM8/ QUADSPI/ SDMMC2/ OTG1_HS/ OTG2_FS/ LCD	I2C4/ UART7/ SWPMI1/ TIM1/8/ DFSDM1/ SDMMC2/ MDIOS/ ETH	TIM1/8/FMC /SDMMC1/ MDIOS/ OTG1_FS/ LCD	TIM1/ DCMI/LCD /COMP	UART5/ LCD	SYS	
Port B	PB8	-	TIM16_CH1	TIM4_CH3	DFSDM1_ CKIN7	I2C1_SCL	-	I2C4_SCL	SDMMC1_ CKIN	UART4_RX	FDCAN1_ RX	SDMMC2_ D4	ETH_MII_ TXD3	SDMMC1_ D4	DCMI_D6	LCD_B6	EVENT- OUT
	PB9	-	TIM17_CH1	TIM4_CH4	DFSDM1_ DATIN7	I2C1_SDA	SPI2_NSS/ I2S2_WS	I2C4_SDA	SDMMC1_ CDIR	UART4_TX	FDCAN1_ TX	SDMMC2_ D5	I2C4_ SMBA	SDMMC1_ D5	DCMI_D7	LCD_B7	EVENT- OUT
	PB10	-	TIM2_CH3	HRTIM_ SCOUT	LPTIM2_IN 1	I2C2_SCL	SPI2_SCK/ I2S2_CK	DFSDM1_ DATIN7	USART3_ TX	-	QUADSPI_ BK1_NCS	OTG_HS_ ULPI_D3	ETH_MII_ RX_ER	-	-	LCD_G4	EVENT- OUT
	PB11	-	TIM2_CH4	HRTIM_ SCIN	LPTIM2_ ETR	I2C2_SDA	-	DFSDM1_ CKIN7	USART3_ RX	-	-	OTG_HS_ ULPI_D4	ETH_MII_ TX_EN/ ETH_RMII_ TX_EN	-	-	LCD_G5	EVENT- OUT
	PB12	-	TIM1_BKIN	-	-	I2C2_SMBA	SPI2_NSS/ I2S2_WS	DFSDM1_ DATIN1	USART3_ CK	-	FDCAN2_ RX	OTG_HS_ ULPI_D5	ETH_MII_ TXD0/ETH_ RMII_TXD0	OTG_HS_ ID	TIM1_ BKIN_ COMP12	UART5_ RX	EVENT- OUT
	PB13	-	TIM1_CH1N	-	LPTIM2_ OUT	-	SPI2_SCK/ I2S2_CK	DFSDM1_ CKIN1	USART3_ CTS/ USART3_ NSS	-	FDCAN2_ TX	OTG_HS_ ULPI_D6	ETH_MII_ TXD1/ETH_ RMII_TXD1	-	-	UART5_ TX	EVENT- OUT
	PB14	-	TIM1_CH2N	TIM12_ CH1	TIM8_ CH2N	USART1_TX	SPI2_MISO/ I2S2_SDI	DFSDM1_ DATIN2	USART3_ RTS/ USART3_ DE	UART4_ RTS/ UART4_ DE	SDMMC2_ D0	-	-	OTG_HS_ DM	-	-	EVENT- OUT
	PB15	RTC_ REFIN	TIM1_CH3N	TIM12_ CH2	TIM8_ CH3N	USART1_RX	SPI2_MOSI/ I2S2_SDO	DFSDM1_ CKIN2	-	UART4_ CTS	SDMMC2_ D1	-	-	OTG_HS_ DP	-	-	EVENT- OUT



Table 10. Port C alternate functions

Port	AF0	AF1	AF2	AF3	AF4	AF5	AF6	AF7	AF8	AF9	AF10	AF11	AF12	AF13	AF14	AF15
	SYS	TIM1/2/16/ 17/LPTIM1/ HRTIM1	SAI1/TIM3/ 4/5/12/ HRTIM1	LPUART/ TIM8/ LPTIM2/3/4 5/HRTIM1/ DFSDM1	I2C1/2/3/4/ USART1/ TIM15/ LPTIM2/ DFSDM1/ CEC	SPI1/2/3/4/ 5/6/CEC	SPI2/3/SAI1 3/I2C4/ UART4/ DFSDM1	SPI2/3/6/ USART1/2/ 3/6/UART7/ SDMMC1	SPI6/SAI2/ 4/UART4/5/ 8/LPUART/ SDMMC1/ SPDIFRX1	SAI4/ FDCAN1/2/ TIM13/14/ QUADSPI/ FMC/ SDMMC2/ LCD/ SPDIFRX1	SAI2/4/ TIM8/ QUADSPI/ SDMMC2/ OTG1_HS/ OTG2_FS/ LCD	I2C4/ UART7/ SWPMI1/ TIM1/8/ DFSDM1/ SDMMC2/ MDIOS/ ETH	TIM1/8/FMC /SDMMC1/ MDIOS/ OTG1_FS/ LCD	TIM1/DCMI /LCD/ COMP	UART5/ LCD	SYS
PC0	-	-	-	DFSDM1_ CKIN0	-	-	DFSDM1_ DATIN4	-	SAI2_FS_B	-	OTG_HS_ ULPI_STP	-	FMC_ SDNWE	-	LCD_R5	EVENT- OUT
PC1	TRACED0	-	SAI1_D1	DFSDM1_ DATIN0	DFSDM1_ CKIN4	SPI2_ MOSI/I2S2_ _SDO	SAI1_SD_A	-	SAI4_SD_ A	SDMMC2_ CK	SAI4_D1	ETH_MDC	MDIOS_ MDC	-	-	EVENT- OUT
PC2	CDSLEEP	-	-	DFSDM1_ CKIN1	-	SPI2_ MISO/I2S2_ _SDI	DFSDM1_ CKOUT	-	-	-	OTG_HS_ ULPI_DIR	ETH_MII_ TXD2	FMC_SDNE 0	-	-	EVENT- OUT
PC3	CSLEEP	-	-	DFSDM1_ DATIN1	-	SPI2_ MOSI/I2S2_ _SDO	-	-	-	-	OTG_HS_ ULPI_NXT	ETH_MII_ TX_CLK	FMC_SDCK E0	-	-	EVENT- OUT
PC4	-	-	-	DFSDM1_ CKIN2	-	I2S1_ MCK	-	-	-	SPDIFRX1_ _IN3	-	ETH_MII_ RXD0/ETH_ RMII_RXD0	FMC_SDNE 0	-	-	EVENT- OUT
PC5	-	-	SAI1_D3	DFSDM1_ DATIN2	-	-	-	-	-	SPDIFRX1_ _IN4	SAI4_D3	ETH_MII_ RXD1/ETH_ RMII_RXD1	FMC_SDCK E0	COMP1_ OUT	-	EVENT- OUT
PC6	-	HRTIM_CH A1	TIM3_CH1	TIM8_CH1	DFSDM1_ CKIN3	I2S2_ MCK	-	USART6_ TX	SDMMC1_ D0DIR	FMC_ NWAiT	SDMMC2_ D6	-	SDMMC1_ D6	DCMI_D0	LCD_ HSYNC	EVENT- OUT
PC7	TRGIO	HRTIM_CH A2	TIM3_CH2	TIM8_CH2	DFSDM1_ DATIN3	-	I2S3_MCK	USART6_ RX	SDMMC1_ D123DIR	FMC_NE1	SDMMC2_ D7	SWPMI_TX	SDMMC1_ D7	DCMI_D1	LCD_G6	EVENT- OUT
PC8	TRACED1	HRTIM_CH B1	TIM3_CH3	TIM8_CH3	-	-	-	USART6_ CK	UART5_ RTS/ UART5_ DE	FMC_NE2/ FMC_NCE	-	SWPMI_RX	SDMMC1_ D0	DCMI_D2	-	EVENT- OUT
PC9	MCO2	-	TIM3_CH4	TIM8_CH4	I2C3_SDA	I2S_CKIN	-	-	UART5_ CTS	QUADSPI_ BK1_IO0	LCD_G3	SWPMI_ SUSPEND	SDMMC1_ D1	DCMI_D3	LCD_B2	EVENT- OUT
PC10	-	-	HRTIM_ EEV1	DFSDM1_ CKIN5	-	-	SPI3_SCK/ I2S3_CK	USART3_ TX	UART4_TX	QUADSPI_ BK1_IO1	-	-	SDMMC1_ D2	DCMI_D8	LCD_R2	EVENT- OUT
PC11	-	-	HRTIM_ FLT2	DFSDM1_ DATIN5	-	-	SPI3_MISO/ I2S3_SDI	USART3_ RX	UART4_RX	QUADSPI_ BK2_NCS	-	-	SDMMC1_ D3	DCMI_D4	-	EVENT- OUT
PC12	TRACED3	-	HRTIM_ EEV2	-	-	-	SPI3_MOSI/ I2S3_SDO	USART3_ CK	UART5_TX	-	-	-	SDMMC1_ CK	DCMI_D9	-	EVENT- OUT
PC13	-	-	-	-	-	-	-	-	-	-	-	-	-	-	-	EVENT- OUT



**Table 10. Port C alternate functions (continued)**

Port	AF0	AF1	AF2	AF3	AF4	AF5	AF6	AF7	AF8	AF9	AF10	AF11	AF12	AF13	AF14	AF15
	SYS	TIM1/2/16/ 17/LPTIM1/ HRTIM1	SAI1/TIM3/ 4/5/12/ HRTIM1	LPUART/ TIM8/ LPTIM2/3/4 /5/HRTIM1/ DFSDM1	I2C1/2/3/4/ USART1/ TIM15/ LPTIM2/ DFSDM1/ CEC	SPI1/2/3/4/ 5/6/CEC	SPI2/3/SAI1 /3/I2C4/ UART4/ DFSDM1	SPI2/3/6/ USART1/2/ 3/6/UART7/ SDMMC1	SPI6/SAI2/ 4/UART4/5/ 8/LPUART/ SDMMC1/ SPDIFRX1	SAI4/ FDCAN1/2/ TIM13/14/ QUADSPI/ FMC/ SDMMC2/ LCD/ SPDIFRX1	SAI2/4/ TIM8/ QUADSPI/ SDMMC2/ OTG1_HS/ OTG2_FS/ LCD	I2C4/ UART7/ SWPMI1/ TIM1/8/ DFSDM1/ SDMMC2/ MDIOS/ ETH	TIM1/8/FMC /SDMMC1/ MDIOS/ OTG1_FS/ LCD	TIM1/DCMI /LCD/ COMP	UART5/ LCD	SYS
PortC	PC14	-	-	-	-	-	-	-	-	-	-	-	-	-	-	EVENT- OUT
	PC15	-	-	-	-	-	-	-	-	-	-	-	-	-	-	EVENT- OUT

**Table 11. Port D alternate functions**

Port	AF0	AF1	AF2	AF3	AF4	AF5	AF6	AF7	AF8	AF9	AF10	AF11	AF12	AF13	AF14	AF15	
	SYS	TIM1/2/16/ 17/LPTIM1/ HRTIM1	SAI1/TIM3/ 4/5/12/ HRTIM1	LPUART/ TIM8/ LPTIM2/3/4 /5/HRTIM1/ DFSDM1	I2C1/2/3/4/ USART1/ TIM15/ LPTIM2/ DFSDM1/ CEC	SPI1/2/3/4/ 5/6/CEC	SPI2/3/SAI1 /3/I2C4/ UART4/ DFSDM1	SPI2/3/6/ USART1/2/ 3/6/UART7/ SDMMC1	SPI6/SAI2/ 4/UART4/5/ 8/LPUART/ SDMMC1/ SPDIFRX1	SAI4/ FDCAN1/2/ TIM13/14/ QUADSPI/ FMC/ SDMMC2/ LCD/ SPDIFRX1	SAI2/4/ TIM8/ QUADSPI/ SDMMC2/ OTG1_HS/ OTG2_FS/ LCD	I2C4/ UART7/ SWPMI1/ TIM1/8/ DFSDM1/ SDMMC2/ MDIOS/ ETH	TIM1/8/FMC /SDMMC1/ MDIOS/ OTG1_FS/ LCD	TIM1/DCMI /LCD/ COMP	UART5/ LCD	SYS	
PortD	PD0	-	-	DFSDM1_ CKIN6	-	-	SAI3_SCK_ A	-	UART4_RX	FDCAN1_ RX	-	-	FMC_D2/ FMC_DA2	-	-	EVENT- OUT	
	PD1	-	-	DFSDM1_ DATIN6	-	-	SAI3_SD_A	-	UART4_TX	FDCAN1_ TX	-	-	FMC_D3/ FMC_DA3	-	-	EVENT- OUT	
	PD2	TRACED2	-	TIM3_ETR	-	-	-	-	UART5_RX	-	-	-	SDMMC1_ CMD	DCMI_D11	-	EVENT- OUT	
	PD3	-	-	DFSDM1_ CKOUT	-	SPI2_SCK/ I2S2_CK	-	USART2_ CTS/ USART2_ NSS	-	-	-	-	-	FMC_CLK	DCMI_D5	LCD_G7	EVENT- OUT
	PD4	-	-	HRTIM_ FLT3	-	-	-	SAI3_FS_A	USART2_ RTS/ USART2_ DE	-	FDCAN1_R XFD_MODE	-	-	FMC_NOE	-	-	EVENT- OUT
	PD5	-	-	HRTIM_ EEV3	-	-	-	-	USART2_ TX	-	FDCAN1_T XFD_MODE	-	-	FMC_NWE	-	-	EVENT- OUT
	PD6	-	-	SAI1_D1	DFSDM1_ CKIN4	DFSDM1_ DATIN1	SPI3_ MOSI/I2S3_ SDO	SAI1_SD_A	USART2_ RX	SAI4_SD_ A	FDCAN2_R XFD_MODE	SAI4_D1	SDMMC2_ CK	FMC_ NWAIT	DCMI_D10	LCD_B2	EVENT- OUT
	PD7	-	-	DFSDM1_ DATIN4	-	-	SPI1_ MOSI/I2S1_ SDO	DFSDM1_ CKIN1	USART2_ CK	-	SPDIFRX1_ IN1	-	SDMMC2_ CMD	FMC_NE1	-	-	EVENT- OUT



Table 11. Port D alternate functions (continued)

Port	AF0	AF1	AF2	AF3	AF4	AF5	AF6	AF7	AF8	AF9	AF10	AF11	AF12	AF13	AF14	AF15	
	SYS	TIM1/2/16/ 17/LPTIM1/ HRTIM1	SAI1/TIM3/ 4/5/12/ HRTIM1	LPUART/ TIM8/ LPTIM2/3/4/ 5/HRTIM1/ DFSDM1	I2C1/2/3/4/ USART1/ TIM15/ LPTIM2/ DFSDM1/ CEC	SPI1/2/3/4/ 5/6/CEC	SPI2/3/SAI1 3/I2C4/ UART4/ DFSDM1	SPI2/3/6/ USART1/2/ 3/6/UART7/ SDMMC1	SPI6/SAI2/ 4/UART4/5/ 8/LPUART/ SDMMC1/ SPDIFRX1	SAI4/ FDCAN1/2/ TIM13/14/ QUADSPI/ FMC/ SDMMC2/ LCD/ SPDIFRX1	SAI2/4/ TIM8/ QUADSPI/ SDMMC2/ OTG1_HS/ OTG2_FS/ LCD	I2C4/ UART7/ SWPMI1/ TIM1/8/ DFSDM1/ SDMMC2/ MDIOS/ ETH	TIM1/8/FMC /SDMMC1/ MDIOS/ OTG1_FS/ LCD	TIM1/DCMI /LCD/ COMP	UART5/ LCD	SYS	
Port D	PD8	-	-	-	DFSDM1_ CKIN3	-	-	SAI3_SCK_ B	USART3_ TX	-	SPDIFRX1_ IN2	-	-	FMC_D13/ FMC_DA13	-	-	EVENT- OUT
	PD9	-	-	-	DFSDM1_ DATIN3	-	-	SAI3_SD_B	USART3_ RX	-	FDCAN2_R XFD_MODE	-	-	FMC_D14/ FMC_DA14	-	-	EVENT- OUT
	PD10	-	-	-	DFSDM1_ CKOUT	-	-	SAI3_FS_B	USART3_ CK	-	FDCAN2_T XFD_MODE	-	-	FMC_D15/ FMC_DA15	-	LCD_B3	EVENT- OUT
	PD11	-	-	-	LPTIM2_ IN2	I2C4_SMBA	-	-	USART3_ CTS/ USART3_N SS	-	QUADSPI_ BK1_IO0	SAI2_SD_A	-	FMC_A16	-	-	EVENT- OUT
	PD12	-	LPTIM1_IN1	TIM4_CH1	LPTIM2_ IN1	I2C4_SCL	-	-	USART3_ RTS/ USART3_ DE	-	QUADSPI_ BK1_IO1	SAI2_FS_A	-	FMC_A17	-	-	EVENT- OUT
	PD13	-	LPTIM1_ OUT	TIM4_CH2	-	I2C4_SDA	-	-	-	-	QUADSPI_ BK1_IO3	SAI2_SCK_ A	-	FMC_A18	-	-	EVENT- OUT
	PD14	-	-	TIM4_CH3	-	-	-	SAI3_MCLK_ B	-	UART8_ CTS	-	-	-	FMC_D0/ FMC_DA0	-	-	EVENT- OUT
	PD15	-	-	TIM4_CH4	-	-	-	SAI3_MCLK_ A	-	UART8_ RTS/ UART8_ DE	-	-	-	FMC_D1/ FMC_DA1	-	-	EVENT- OUT

**Table 12. Port E alternate functions**

Port	AF0	AF1	AF2	AF3	AF4	AF5	AF6	AF7	AF8	AF9	AF10	AF11	AF12	AF13	AF14	AF15
	SYS	TIM1/2/16/17/LPTIM1/HRTIM1	SAI1/TIM3/4/5/12/HRTIM1	LPUART/TIM8/LPTIM2/3/4/5/HRTIM1/DFSDM1	I2C1/2/3/4/USART1/TIM15/LPTIM2/DFSDM1/CEC	SPI1/2/3/4/5/6/CEC	SPI2/3/SAI1/3/I2C4/UART4/DFSDM1	SPI2/3/6/USART1/2/3/6/UART7/SDMMC1	SPI6/SAI2/4/UART4/5/8/LPUART/SDMMC1/SPDIFRX1	SAI4/FDCAN1/2/TIM13/14/QUADSPI/FMC/SDMMC2/LCD/SPDIFRX1	SAI2/4/TIM8/QUADSPI/SDMMC2/OTG1_HS/OTG2_FS/LCD	I2C4/UART7/SWPMI1/TIM1/8/DFSDM1/SDMMC2/MDIOS/ETH	TIM1/8/FMC/SDMMC1/MDIOS/OTG1_FS/LCD	TIM1/DCMI/LCD/COMP	UART5/LCD	SYS
PE0	-	LPTIM1_ETR	TIM4_ETR	HRTIM_SCIN	LPTIM2_ETR	-	-	-	UART8_RX	FDCAN1_RXFD_MODE	SAI2_MCLK_A	-	FMC_NBL0	DCMI_D2	-	EVENT-OUT
PE1	-	LPTIM1_IN2	-	HRTIM_SCOUT	-	-	-	-	UART8_TX	FDCAN1_TXFD_MODE	-	-	FMC_NBL1	DCMI_D3	-	EVENT-OUT
PE2	TRACE_CLK	-	SAI1_CK1	-	-	SPI4_SCK	SAI1_MCLK_A	-	SAI4_MCLK_A	QUADSPI_BK1_IO2	SAI4_CK1	ETH_MII_TXD3	FMC_A23	-	-	EVENT-OUT
PE3	TRACED0	-	-	-	TIM15_BKIN	-	SAI1_SD_B	-	SAI4_SD_B	-	-	-	FMC_A19	-	-	EVENT-OUT
PE4	TRACED1	-	SAI1_D2	DFSDM1_DATIN3	TIM15_CH1_N	SPI4_NSS	SAI1_FS_A	-	SAI4_FS_A	-	SAI4_D2	-	FMC_A20	DCMI_D4	LCD_B0	EVENT-OUT
PE5	TRACED2	-	SAI1_CK2	DFSDM1_CKIN3	TIM15_CH1	SPI4_MISO	SAI1_SCK_A	-	SAI4_SCK_A	-	SAI4_CK2	-	FMC_A21	DCMI_D6	LCD_G0	EVENT-OUT
PE6	TRACED3	TIM1_BKIN2	SAI1_D1	-	TIM15_CH2	SPI4_MOSI	SAI1_SD_A	-	SAI4_SD_A	SAI4_D1	SAI2_MCLK_B	TIM1_BKIN2_COMP12	FMC_A22	DCMI_D7	LCD_G1	EVENT-OUT
PE7	-	TIM1_ETR	-	DFSDM1_DATIN2	-	-	-	UART7_RX	-	-	QUADSPI_BK2_IO0	-	FMC_D4/FMC_DA4	-	-	EVENT-OUT
PE8	-	TIM1_CH1N	-	DFSDM1_CKIN2	-	-	-	UART7_TX	-	-	QUADSPI_BK2_IO1	-	FMC_D5/FMC_DA5	COMP2_OUT	-	EVENT-OUT
PE9	-	TIM1_CH1	-	DFSDM1_CKOUT	-	-	-	UART7_RTS/UART7_DE	-	-	QUADSPI_BK2_IO2	-	FMC_D6/FMC_DA6	-	-	EVENT-OUT
PE10	-	TIM1_CH2N	-	DFSDM1_DATIN4	-	-	-	UART7_CTS	-	-	QUADSPI_BK2_IO3	-	FMC_D7/FMC_DA7	-	-	EVENT-OUT
PE11	-	TIM1_CH2	-	DFSDM1_CKIN4	-	SPI4_NSS	-	-	-	-	SAI2_SD_B	-	FMC_D8/FMC_DA8	-	LCD_G3	EVENT-OUT
PE12	-	TIM1_CH3N	-	DFSDM1_DATIN5	-	SPI4_SCK	-	-	-	-	SAI2_SCK_B	-	FMC_D9/FMC_DA9	COMP1_OUT	LCD_B4	EVENT-OUT
PE13	-	TIM1_CH3	-	DFSDM1_CKIN5	-	SPI4_MISO	-	-	-	-	SAI2_FS_B	-	FMC_D10/FMC_DA10	COMP2_OUT	LCD_DE	EVENT-OUT



Table 12. Port E alternate functions (continued)

Port		AF0	AF1	AF2	AF3	AF4	AF5	AF6	AF7	AF8	AF9	AF10	AF11	AF12	AF13	AF14	AF15
Port		SYS	TIM1/2/16/17/LPTIM1/HRTIM1	SAI1/TIM3/4/5/12/HRTIM1	LPUART/TIM8/LPTIM2/3/4/5/HRTIM1/DFSDM1	I2C1/2/3/4/USART1/TIM15/LPTIM2/DFSDM1/CEC	SPI1/2/3/4/5/6/CEC	SPI2/3/SAI1/3/I2C4/UART4/DFSDM1	SPI2/3/6/USART1/2/3/6/UART7/SDMMC1	SPI6/SAI2/4/UART4/5/8/LPUART/SDMMC1/SPDIFRX1	SAI4/FDCAN1/2/TIM13/14/QUADSPI/FMC/SDMMC2/LCD/SPDIFRX1	SAI2/4/TIM8/QUADSPI/SDMMC2/OTG1_HS/OTG2_FS/LCD	I2C4/UART7/SWPMI1/TIM1/8/DFSDM1/SDMMC2/MDIOS/ETH	TIM1/8/FMC/SDMMC1/MDIOS/OTG1_FS/LCD	TIM1/DCMI/LCD/COMP	UART5/LCD	SYS
Port E	PE14	-	TIM1_CH4	-	-	-	SPI4_MOSI	-	-	-	-	SAI2_MCLK_B	-	FMC_D11/FMC_DA11	-	LCD_CLK	EVENT-OUT
	PE15	-	TIM1_BKIN	-	-	-	-	-	-	-	-	-	-	FMC_D12/FMC_DA12	TIM1_BKIN_COMP12/TIM1_BKIN	LCD_R7	EVENT-OUT



**Table 13. Port F alternate functions**

Port	AF0	AF1	AF2	AF3	AF4	AF5	AF6	AF7	AF8	AF9	AF10	AF11	AF12	AF13	AF14	AF15	
	SYS	TIM1/2/16/ 17/LPTIM1/ HRTIM1	SAI1/TIM3/ 4/5/12/ HRTIM1	LPUART/ TIM8/ LPTIM2/3/4 5/HRTIM1/ DFSDM1	I2C1/2/3/4/ USART1/ TIM15/ LPTIM2/ DFSDM1/ CEC	SPI1/2/3/4/ 5/6/CEC	SPI2/3/SAI1 3/I2C4/ UART4/ DFSDM1	SPI2/3/6/ USART1/2/ 3/6/UART7/ SDMMC1	SPI6/SAI2/ 4/UART4/5/ 8/LPUART/ SDMMC1/ SPDIFRX1	SAI4/ FDCAN1/2/ TIM13/14/ QUADSPI/ FMC/ SDMMC2/ LCD/ SPDIFRX1	SAI2/4/ TIM8/ QUADSPI/ SDMMC2/ OTG1_HS/ OTG2_FS/ LCD	I2C4/ UART7/ SWPMI1/ TIM1/8/ DFSDM1/ SDMMC2/ MDIOS/ ETH	TIM1/8/FMC /SDMMC1/ MDIOS/ OTG1_FS/ LCD	TIM1/DCMI /LCD/ COMP	UART5/ LCD	SYS	
Port F	PF0	-	-	-	-	I2C2_SDA	-	-	-	-	-	-	FMC_A0	-	-	EVENT- OUT	
	PF1	-	-	-	-	I2C2_SCL	-	-	-	-	-	-	FMC_A1	-	-	EVENT- OUT	
	PF2	-	-	-	-	I2C2_SMBA	-	-	-	-	-	-	FMC_A2	-	-	EVENT- OUT	
	PF3	-	-	-	-	-	-	-	-	-	-	-	FMC_A3	-	-	EVENT- OUT	
	PF4	-	-	-	-	-	-	-	-	-	-	-	FMC_A4	-	-	EVENT- OUT	
	PF5	-	-	-	-	-	-	-	-	-	-	-	FMC_A5	-	-	EVENT- OUT	
	PF6	-	TIM16_CH1	-	-	-	SPI5_NSS	SAI1_SD_B	UART7_RX	SAI4_SD_B	QUADSPI_ BK1_IO3	-	-	-	-	-	EVENT- OUT
	PF7	-	TIM17_CH1	-	-	-	SPI5_SCK	SAI1_MCLK_B	UART7_TX	SAI4_MCLK_B	QUADSPI_ BK1_IO2	-	-	-	-	-	EVENT- OUT
	PF8	-	TIM16_CH1N	-	-	-	SPI5_MISO	SAI1_SCK_B	UART7_RTS/ UART7_DE	SAI4_SCK_B	TIM13_CH1	QUADSPI_ BK1_IO0	-	-	-	-	EVENT- OUT
	PF9	-	TIM17_CH1N	-	-	-	SPI5_MOSI	SAI1_FS_B	UART7_CTS	SAI4_FS_B	TIM14_CH1	QUADSPI_ BK1_IO1	-	-	-	-	EVENT- OUT
	PF10	-	TIM16_BKIN	SAI1_D3	-	-	-	-	-	-	QUADSPI_ CLK	SAI4_D3	-	-	DCMI_D11	LCD_DE	EVENT- OUT
	PF11	-	-	-	-	-	SPI5_MOSI	-	-	-	-	SAI2_SD_B	-	FMC_SDNRAS	DCMI_D12	-	EVENT- OUT
	PF12	-	-	-	-	-	-	-	-	-	-	-	-	FMC_A6	-	-	EVENT- OUT
	PF13	-	-	-	-	DFSDM1_DATIN6	I2C4_SMBA	-	-	-	-	-	-	FMC_A7	-	-	EVENT- OUT
	PF14	-	-	-	-	DFSDM1_CKIN6	I2C4_SCL	-	-	-	-	-	-	FMC_A8	-	-	EVENT- OUT
	PF15	-	-	-	-	-	I2C4_SDA	-	-	-	-	-	-	FMC_A9	-	-	EVENT- OUT



Table 14. Port G alternate functions

Port	AF0	AF1	AF2	AF3	AF4	AF5	AF6	AF7	AF8	AF9	AF10	AF11	AF12	AF13	AF14	AF15
	SYS	TIM1/2/16/ 17/LPTIM1/ HRTIM1	SAI1/TIM3/ 4/5/12/ HRTIM1	LPUART/ TIM8/ LPTIM2/3/4/ 5/HRTIM1/ DFSDM1	I2C1/2/3/4/ USART1/ TIM15/ LPTIM2/ DFSDM1/ CEC	SPI1/2/3/4/ 5/6/CEC	SPI2/3/SAI1 /3/I2C4/ UART4/ DFSDM1	SPI2/3/6/ USART1/2/ 3/6/UART7/ SDMMC1	SPI6/SAI2/ 4/UART4/5/ 8/LPUART/ SDMMC1/ SPDIFRX1	SAI4/ FDCAN1/2/ TIM13/14/ QUADSPI/ FMC/ SDMMC2/ LCD/ SPDIFRX1	SAI2/4/TIM8/ QUADSPI/ SDMMC2/ OTG1_HS/ OTG2_FS/ LCD	I2C4/UART7 /SWPMI1/ TIM1/8/ DFSDM1/ SDMMC2/ MDIOS/ETH	TIM1/8/FMC /SDMMC1/ MDIOS/ OTG1_FS/ LCD	TIM1/ DCMI/LCD /COMP	UART5/ LCD	SYS
PG0	-	-	-	-	-	-	-	-	-	-	-	-	FMC_A10	-	-	EVENT -OUT
PG1	-	-	-	-	-	-	-	-	-	-	-	-	FMC_A11	-	-	EVENT -OUT
PG2	-	-	-	TIM8_BKIN	-	-	-	-	-	-	-	TIM8_BKIN_ COMP12	FMC_A12	-	-	EVENT -OUT
PG3	-	-	-	TIM8_ BKIN2	-	-	-	-	-	-	-	TIM8_BKIN2_ COMP12	FMC_A13	-	-	EVENT -OUT
PG4	-	TIM1_ BKIN2	-	-	-	-	-	-	-	-	-	TIM1_BKIN2_ COMP12	FMC_A14/ FMC_BA0	-	-	EVENT -OUT
PG5	-	TIM1_ETR	-	-	-	-	-	-	-	-	-	-	FMC_A15/ FMC_BA1	-	-	EVENT -OUT
PG6	-	TIM17_ BKIN	HRTIM_ CHE1	-	-	-	-	-	-	-	QUADSPI_ BK1_NCS	-	FMC_NE3	DCMI_ D12	LCD_ R7	EVENT -OUT
PG7	-	-	HRTIM_ CHE2	-	-	-	SAI1_ MCLK_A	USART6_ CK	-	-	-	-	FMC_INT	DCMI_ D13	LCD_ CLK	EVENT -OUT
PG8	-	-	-	TIM8_ETR	-	SPI6_NSS	-	USART6_ RTS/ USART6_ DE	SPDIFRX1_ IN3	-	-	ETH_PPS_ OUT	FMC_ SDCLK	-	LCD_ G7	EVENT -OUT
PG9	-	-	-	-	-	SPI1_ MISO/I2S1_ SDI	-	USART6_ RX	SPDIFRX1_ IN4	QUADSPI_ BK2_IO2	SAI2_FS_B	-	FMC_NE2/ FMC_NCE	DCMI_ VSYNC	-	EVENT -OUT
PG10	-	-	HRTIM_ FLT5	-	-	SPI1_NSS/ I2S1_WS	-	-	-	LCD_G3	SAI2_SD_B	-	FMC_NE3	DCMI_D2	LCD_ B2	EVENT -OUT
PG11	-	LPTIM1_IN2	HRTIM_ EEV4	-	-	SPI1_SCK/ I2S1_CK	-	-	SPDIFRX1_ IN1	-	SDMMC2_D2	ETH_MII_ TX_EN/ ETH_RMII_ TX_EN	-	DCMI_D3	LCD_ B3	EVENT -OUT
PG12	-	LPTIM1_IN1	HRTIM_ EEV5	-	-	SPI6_ MISO	-	USART6_ RTS/ USART6_ DE	SPDIFRX1_ IN2	LCD_B4	-	ETH_MII_ TXD1/ETH_ RMII_TXD1	FMC_NE4	-	LCD_ B1	EVENT -OUT
PG13	TRACED0	LPTIM1_ OUT	HRTIM_ EEV10	-	-	SPI6_SCK	-	USART6_ CTS/ USART6_ NSS	-	-	-	ETH_MII_ TXD0/ETH_ RMII_TXD0	FMC_A24	-	LCD_ R0	EVENT -OUT

Port G





**Table 14. Port G alternate functions (continued)**

Port	AF0	AF1	AF2	AF3	AF4	AF5	AF6	AF7	AF8	AF9	AF10	AF11	AF12	AF13	AF14	AF15	
	SYS	TIM1/2/16/ 17/LPTIM1/ HRTIM1	SAI1/TIM3/ 4/5/12/ HRTIM1	LPUART/ TIM8/ LPTIM2/3/4/ 5/HRTIM1/ DFSDM1	I2C1/2/3/4/ USART1/ TIM15/ LPTIM2/ DFSDM1/ CEC	SPI1/2/3/4/ 5/6/CEC	SPI2/3/SAI1 /3/I2C4/ UART4/ DFSDM1	SPI2/3/6/ USART1/2/ 3/6/UART7/ SDMMC1	SPI6/SAI2/ 4/UART4/5/ 8/LPUART/ SDMMC1/ SPDIFRX1	SAI4/ FDCAN1/2/ TIM13/14/ QUADSPI/ FMC/ SDMMC2/ LCD/ SPDIFRX1	SAI2/4/TIM8/ QUADSPI/ SDMMC2/ OTG1_HS/ OTG2_FS/ LCD	I2C4/UART7 /SWPMI1/ TIM1/8/ DFSDM1/ SDMMC2/ MDIOS/ETH	TIM1/8/FMC /SDMMC1/ MDIOS/ OTG1_FS/ LCD	TIM1/ DCMI/LCD /COMP	UART5/ LCD	SYS	
Port G	PG14	TRACED1	LPTIM1_ETR	-	-	-	SPI6_MOSI	-	USART6_TX	-	QUADSPI_BK2_IO3	-	ETH_MII_TXD1/ETH_RMII_TXD1	FMC_A25	-	LCD_B0	EVENT_OUT
	PG15	-	-	-	-	-	-	-	USART6_CTS/ USART6_NSS	-	-	-	-	FMC_SDNCAS	DCMI_D13	-	EVENT_OUT



Table 15. Port H alternate functions

Port	AF0	AF1	AF2	AF3	AF4	AF5	AF6	AF7	AF8	AF9	AF10	AF11	AF12	AF13	AF14	AF15
	SYS	TIM1/2/16/ 17/LPTIM1/ HRTIM1	SAI1/TIM3/ 4/5/12/ HRTIM1	LPUART/ TIM8/ LPTIM2/3/4/ 5/HRTIM1/ DFSDM1	I2C1/2/3/4/ USART1/ TIM15/ LPTIM2/ DFSDM1/ CEC	SPI1/2/3/4/ 5/6/CEC	SPI2/3/SAI1 3/I2C4/ UART4/ DFSDM1	SPI2/3/6/ USART1/2/ 3/6/UART7/ SDMMC1	SPI6/SAI2/ 4/UART4/5/ 8/LPUART/ SDMMC1/ SPDIFRX1	SAI4/ FDCAN1/2/ TIM13/14/ QUADSPI/ FMC/ SDMMC2/ LCD/ SPDIFRX1	SAI2/4/ TIM8/ QUADSPI/ SDMMC2/ OTG1_HS/ OTG2_FS/ LCD	I2C4/ UART7/ SWPMI1/ TIM1/8/ DFSDM1/ SDMMC2/ MDIOS/ ETH	TIM1/8/FMC /SDMMC1/ MDIOS/ OTG1_FS/ LCD	TIM1/DCMI /LCD/ COMP	UART5/ LCD	SYS
PH0	-	-	-	-	-	-	-	-	-	-	-	-	-	-	-	EVENT- OUT
PH1	-	-	-	-	-	-	-	-	-	-	-	-	-	-	-	EVENT- OUT
PH2	-	LPTIM1_IN2	-	-	-	-	-	-	-	QUADSPI_ BK2_IO0	SAI2_SCK_ B	ETH_MII_ CRS	FMC_ SDCKE0	-	LCD_R0	EVENT- OUT
PH3	-	-	-	-	-	-	-	-	-	QUADSPI_ BK2_IO1	SAI2_ MCLK_B	ETH_MII_ COL	FMC_ SDNE0	-	LCD_R1	EVENT- OUT
PH4	-	-	-	-	I2C2_SCL	-	-	-	-	LCD_G5	OTG_HS_ ULPI_NXT	-	-	-	LCD_G4	EVENT- OUT
PH5	-	-	-	-	I2C2_SDA	SPI5_NSS	-	-	-	-	-	-	FMC_ SDNWE	-	-	EVENT- OUT
PH6	-	-	TIM12_ CH1	-	I2C2_SMBA	SPI5_SCK	-	-	-	-	-	ETH_MII_ RXD2	FMC_ SDNE1	DCMI_D8	-	EVENT- OUT
PH7	-	-	-	-	I2C3_SCL	SPI5_ MISO	-	-	-	-	-	ETH_MII_ RXD3	FMC_ SDCKE1	DCMI_D9	-	EVENT- OUT
PH8	-	-	TIM5_ETR	-	I2C3_SDA	-	-	-	-	-	-	-	FMC_D16	DCMI_ HSYNC	LCD_R2	EVENT- OUT
PH9	-	-	TIM12_ CH2	-	I2C3_SMBA	-	-	-	-	-	-	-	FMC_D17	DCMI_D0	LCD_R3	EVENT- OUT
PH10	-	-	TIM5_CH1	-	I2C4_SMBA	-	-	-	-	-	-	-	FMC_D18	DCMI_D1	LCD_R4	EVENT- OUT
PH11	-	-	TIM5_CH2	-	I2C4_SCL	-	-	-	-	-	-	-	FMC_D19	DCMI_D2	LCD_R5	EVENT- OUT
PH12	-	-	TIM5_CH3	-	I2C4_SDA	-	-	-	-	-	-	-	FMC_D20	DCMI_D3	LCD_R6	EVENT- OUT
PH13	-	-	-	TIM8_ CH1N	-	-	-	-	UART4_TX	FDCAN1_ TX	-	-	FMC_D21	-	LCD_G2	EVENT- OUT
PH14	-	-	-	TIM8_ CH2N	-	-	-	-	UART4_RX	FDCAN1_ RX	-	-	FMC_D22	DCMI_D4	LCD_G3	EVENT- OUT
PH15	-	-	-	TIM8_ CH3N	-	-	-	-	-	FDCAN1_ TXFD_ MODE	-	-	FMC_D23	DCMI_D11	LCD_G4	EVENT- OUT



**Table 16. Port I alternate functions**

Port	AF0	AF1	AF2	AF3	AF4	AF5	AF6	AF7	AF8	AF9	AF10	AF11	AF12	AF13	AF14	AF15
	SYS	TIM1/2/16/ 17/LPTIM1/ HRTIM1	SAI1/TIM3/ 4/5/12/ HRTIM1	LPUART/ TIM8/ LPTIM2/3/4/ 5/HRTIM1/ DFSDM1	I2C1/2/3/4/ USART1/ TIM15/ LPTIM2/ DFSDM1/ CEC	SPI1/2/3/4/ 5/6/CEC	SPI2/3/SAI1 3/I2C4/ UART4/ DFSDM1	SPI2/3/6/ USART1/2/ 3/6/UART7/ SDMMC1	SPI6/SAI2/ 4/UART4/5/ 8/LPUART/ SDMMC1/ SPDIFRX1	SAI4/ FDCAN1/2/ TIM13/14/ QUADSPI/ FMC/ SDMMC2/ LCD/ SPDIFRX1	SAI2/4/ TIM8/ QUADSPI/ SDMMC2/ OTG1_HS/ OTG2_FS/ LCD	I2C4/ UART7/ SWPMI1/ TIM1/8/ DFSDM1/ SDMMC2/ MDIOS/ ETH	TIM1/8/FMC /SDMMC1/ MDIOS/ OTG1_FS/ LCD	TIM1/DCMI /LCD/ COMP	UART5/ LCD	SYS
PI0	-	-	TIM5_CH4	-	-	SPI2_NSS/ I2S2_VS	-	-	-	FDCAN1_ RXFD_ MODE	-	-	FMC_D24	DCMI_D13	LCD_G5	EVENT- OUT
PI1	-	-	-	TIM8_ BKIN2	-	SPI2_SCK/ I2S2_CK	-	-	-	-	-	TIM8_BKIN 2_COMP12	FMC_D25	DCMI_D8	LCD_G6	EVENT- OUT
PI2	-	-	-	TIM8_CH4	-	SPI2_ MISO/I2S2_ SDI	-	-	-	-	-	-	FMC_D26	DCMI_D9	LCD_G7	EVENT- OUT
PI3	-	-	-	TIM8_ETR	-	SPI2_ MOS/I2S2_ SDO	-	-	-	-	-	-	FMC_D27	DCMI_D10	-	EVENT- OUT
PI4	-	-	-	TIM8_BKIN	-	-	-	-	-	-	SAI2_ MCLK_A	TIM8_BKIN 2_COMP12	FMC_NBL2	DCMI_D5	LCD_B4	EVENT- OUT
PI5	-	-	-	TIM8_CH1	-	-	-	-	-	-	SAI2_SCK_ A	-	FMC_NBL3	DCMI_ VSYNC	LCD_B5	EVENT- OUT
PI6	-	-	-	TIM8_CH2	-	-	-	-	-	-	SAI2_SD_A	-	FMC_D28	DCMI_D6	LCD_B6	EVENT- OUT
PI7	-	-	-	TIM8_CH3	-	-	-	-	-	-	SAI2_FS_A	-	FMC_D29	DCMI_D7	LCD_B7	EVENT- OUT
PI8	-	-	-	-	-	-	-	-	-	-	-	-	-	-	-	EVENT- OUT
PI9	-	-	-	-	-	-	-	-	UART4_RX	FDCAN1_ RX	-	-	FMC_D30	-	LCD_ VSYNC	EVENT- OUT
PI10	-	-	-	-	-	-	-	-	-	FDCAN1_ RXFD_ MODE	-	ETH_MII_ RX_ER	FMC_D31	-	LCD_ HSYNC	EVENT- OUT
PI11	-	-	-	-	-	-	-	-	-	LCD_G6	OTG_HS_ ULPI_DIR	-	-	-	-	EVENT- OUT
PI12	-	-	-	-	-	-	-	-	-	-	-	-	-	-	LCD_ HSYNC	EVENT- OUT
PI13	-	-	-	-	-	-	-	-	-	-	-	-	-	-	LCD_ VSYNC	EVENT- OUT
PI14	-	-	-	-	-	-	-	-	-	-	-	-	-	-	LCD_CLK	EVENT- OUT
PI15	-	-	-	-	-	-	-	-	-	LCD_G2	-	-	-	-	LCD_R0	EVENT- OUT



Table 17. Port J alternate functions

Port	AF0	AF1	AF2	AF3	AF4	AF5	AF6	AF7	AF8	AF9	AF10	AF11	AF12	AF13	AF14	AF15
	SYS	TIM1/2/16/ 17/LPTIM1/ HRTIM1	SAI1/TIM3/ 4/5/12/ HRTIM1	LPUART/ TIM8/ LPTIM2/3/4/ 5/HRTIM1/ DFSDM1	I2C1/2/3/4/ USART1/ TIM15/ LPTIM2/ DFSDM1/ CEC	SPI1/2/3/4/ 5/6/CEC	SPI2/3/SAI1 3/I2C4/ UART4/ DFSDM1	SPI2/3/6/ USART1/2/ 3/6/UART7/ SDMMC1	SP16/SAI2/ 4/UART4/5/ 8/LPUART/ SDMMC1/ SPDIFRX1	SAI4/ FDCAN1/2/ TIM13/14/ QUADSPI/ FMC/ SDMMC2/ LCD/ SPDIFRX1	SAI2/4/ TIM8/ QUADSPI/ SDMMC2/ OTG1_HS/ OTG2_FS/ LCD	I2C4/ UART7/ SWPMI1/ TIM1/8/ DFSDM1/ SDMMC2/ MDIOS/ ETH	TIM1/8/FMC /SDMMC1/ MDIOS/ OTG1_FS/ LCD	TIM1/DCMI /LCD/ COMP	UART5/ LCD	SYS
PJ0	-	-	-	-	-	-	-	-	-	LCD_R7	-	-	-	-	LCD_R1	EVENT- OUT
PJ1	-	-	-	-	-	-	-	-	-	-	-	-	-	-	LCD_R2	EVENT- OUT
PJ2	-	-	-	-	-	-	-	-	-	-	-	-	-	-	LCD_R3	EVENT- OUT
PJ3	-	-	-	-	-	-	-	-	-	-	-	-	-	-	LCD_R4	EVENT- OUT
PJ4	-	-	-	-	-	-	-	-	-	-	-	-	-	-	LCD_R5	EVENT- OUT
PJ5	-	-	-	-	-	-	-	-	-	-	-	-	-	-	LCD_R6	EVENT- OUT
PJ6	-	-	-	TIM8_CH2	-	-	-	-	-	-	-	-	-	-	LCD_R7	EVENT- OUT
PJ7	TRGIN	-	-	TIM8_CH2N	-	-	-	-	-	-	-	-	-	-	LCD_G0	EVENT- OUT
PJ8	-	TIM1_CH3N	-	TIM8_CH1	-	-	-	-	UART8_TX	-	-	-	-	-	LCD_G1	EVENT- OUT
PJ9	-	TIM1_CH3	-	TIM8_CH1N	-	-	-	-	UART8_RX	-	-	-	-	-	LCD_G2	EVENT- OUT
PJ10	-	TIM1_CH2N	-	TIM8_CH2	-	SPI5_MOSI	-	-	-	-	-	-	-	-	LCD_G3	EVENT- OUT
PJ11	-	TIM1_CH2	-	TIM8_CH2N	-	SPI5_MISO	-	-	-	-	-	-	-	-	LCD_G4	EVENT- OUT
PJ12	TRGOUT	-	-	-	-	-	-	-	-	LCD_G3	-	-	-	-	LCD_B0	EVENT- OUT
PJ13	-	-	-	-	-	-	-	-	-	LCD_B4	-	-	-	-	LCD_B1	EVENT- OUT
PJ14	-	-	-	-	-	-	-	-	-	-	-	-	-	-	LCD_B2	EVENT- OUT
PJ15	-	-	-	-	-	-	-	-	-	-	-	-	-	-	LCD_B3	EVENT- OUT



**Table 18. Port K alternate functions**

Port	AF0	AF1	AF2	AF3	AF4	AF5	AF6	AF7	AF8	AF9	AF10	AF11	AF12	AF13	AF14	AF15	
	SYS	TIM1/2/16/17/LPTIM1/HRTIM1	SAI1/TIM3/4/5/12/HRTIM1	LPUART/TIM8/LPTIM2/3/4/5/HRTIM1/DFSDM1	I2C1/2/3/4/USART1/TIM15/LPTIM2/DFSDM1/CEC		SPI1/2/3/4/5/6/CEC	SPI2/3/SAI1/3/I2C4/UART4/DFSDM1	SPI2/3/6/USART1/2/3/6/UART7/SDMMC1	SPI6/SAI2/4/UART4/5/8/LPUART/SDMMC1/SPDIFRX1	SAI4/FDCAN1/2/TIM13/14/QUADSPI/FMC/SDMMC2/LCD/SPDIFRX1	SAI2/4/TIM8/QUADSPI/SDMMC2/OTG1_HS/OTG2_FS/LCD	I2C4/UART7/SWPMI1/TIM1/8/DFSDM1/SDMMC2/MDIOS/ETH	TIM1/8/FMC/SDMMC1/MDIOS/OTG1_FS/LCD	TIM1/DCMI/LCD/COMP	UART5/LCD	SYS
Port K	PK0	-	TIM1_CH1N	-	TIM8_CH3	-	SPI5_SCK	-	-	-	-	-	-	-	LCD_G5	EVENT-OUT	
	PK1	-	TIM1_CH1	-	TIM8_CH3N	-	SPI5_NSS	-	-	-	-	-	-	-	LCD_G6	EVENT-OUT	
	PK2	-	TIM1_BKIN	-	TIM8_BKIN	-	-	-	-	-	-	TIM8_BKIN_COMP12	TIM1_BKIN_COMP12	-	-	LCD_G7	EVENT-OUT
	PK3	-	-	-	-	-	-	-	-	-	-	-	-	-	LCD_B4	EVENT-OUT	
	PK4	-	-	-	-	-	-	-	-	-	-	-	-	-	LCD_B5	EVENT-OUT	
	PK5	-	-	-	-	-	-	-	-	-	-	-	-	-	LCD_B6	EVENT-OUT	
	PK6	-	-	-	-	-	-	-	-	-	-	-	-	-	LCD_B7	EVENT-OUT	
	PK7	-	-	-	-	-	-	-	-	-	-	-	-	-	LCD_DE	EVENT-OUT	

## 6 Electrical characteristics (rev Y)

### 6.1 Parameter conditions

Unless otherwise specified, all voltages are referenced to  $V_{SS}$ .

#### 6.1.1 Minimum and maximum values

Unless otherwise specified the minimum and maximum values are guaranteed in the worst conditions of junction temperature, supply voltage and frequencies by tests in production on 100% of the devices with an junction temperature at  $T_J = 25\text{ }^\circ\text{C}$  and  $T_J = T_{Jmax}$  (given by the selected temperature range).

Data based on characterization results, design simulation and/or technology characteristics are indicated in the table footnotes. Based on characterization, the minimum and maximum values refer to sample tests and represent the mean value plus or minus three times the standard deviation ( $\text{mean} \pm 3\sigma$ ).

#### 6.1.2 Typical values

Unless otherwise specified, typical data are based on  $T_J = 25\text{ }^\circ\text{C}$ ,  $V_{DD} = 3.3\text{ V}$  (for the  $1.7\text{ V} \leq V_{DD} \leq 3.6\text{ V}$  voltage range). They are given only as design guidelines and are not tested.

Typical ADC accuracy values are determined by characterization of a batch of samples from a standard diffusion lot over the full temperature range, where 95% of the devices have an error less than or equal to the value indicated ( $\text{mean} \pm 2\sigma$ ).

#### 6.1.3 Typical curves

Unless otherwise specified, all typical curves are given only as design guidelines and are not tested.

#### 6.1.4 Loading capacitor

The loading conditions used for pin parameter measurement are shown in [Figure 9](#).

#### 6.1.5 Pin input voltage

The input voltage measurement on a pin of the device is described in [Figure 10](#).

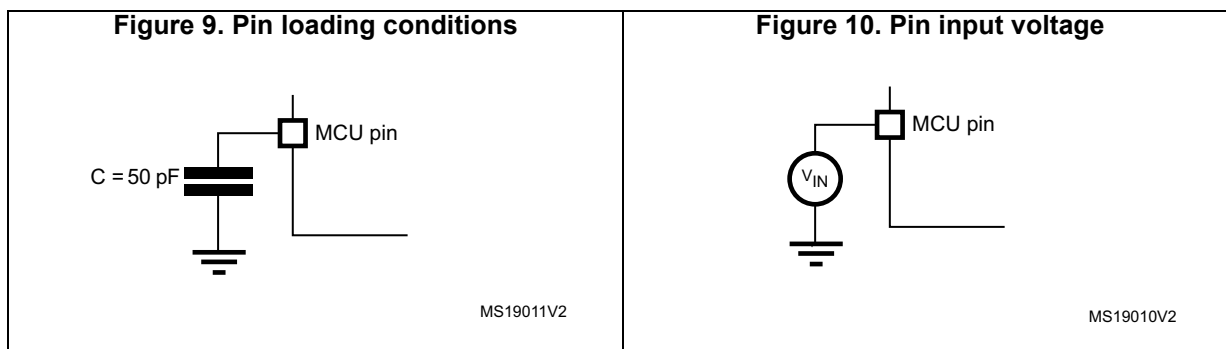

6.1.6 Power supply scheme

Figure 11. Power supply scheme

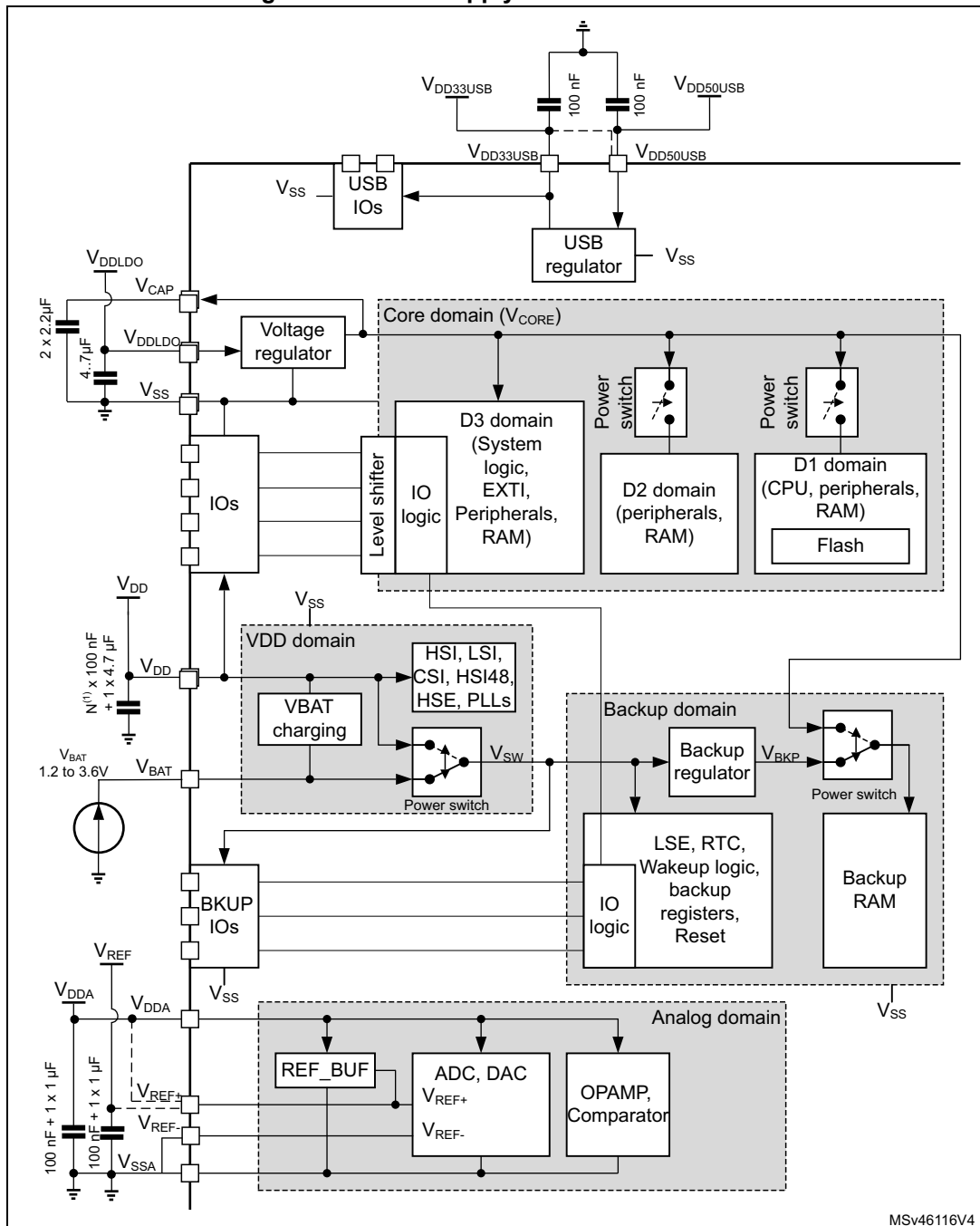

1. N corresponds to the number of VDD pins available on the package.
2. A tolerance of +/- 20% is acceptable on decoupling capacitors.

**Caution:** Each power supply pair ( $V_{DD}/V_{SS}$ ,  $V_{DDA}/V_{SSA}$  ...) must be decoupled with filtering ceramic capacitors as shown above. These capacitors must be placed as close as possible to, or below, the appropriate pins on the underside of the PCB to ensure good operation of the

device. It is not recommended to remove filtering capacitors to reduce PCB size or cost. This might cause incorrect operation of the device.

### 6.1.7 Current consumption measurement

Figure 12. Current consumption measurement scheme

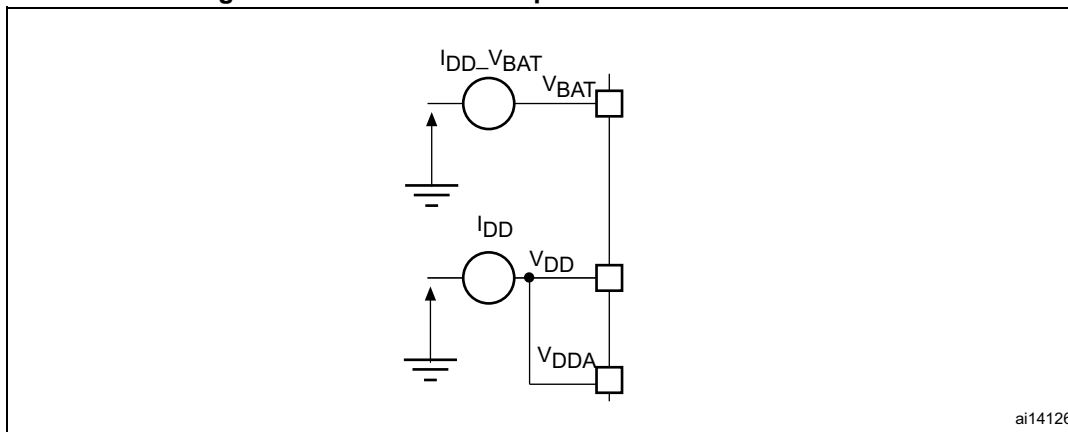

## 6.2 Absolute maximum ratings

Stresses above the absolute maximum ratings listed in [Table 19: Voltage characteristics](#), [Table 20: Current characteristics](#), and [Table 21: Thermal characteristics](#) may cause permanent damage to the device. These are stress ratings only and the functional operation of the device at these conditions is not implied. Exposure to maximum rating conditions for extended periods may affect device reliability. Device mission profile (application conditions) is compliant with JEDEC JESD47 Qualification Standard, extended mission profiles are available on demand.

Table 19. Voltage characteristics <sup>(1)</sup>

Symbols	Ratings	Min	Max	Unit
$V_{DDX} - V_{SS}$	External main supply voltage (including $V_{DD}$ , $V_{DDLDO}$ , $V_{DDA}$ , $V_{DD33USB}$ , $V_{BAT}$ )	-0.3	4.0	V
$V_{IN}^{(2)}$	Input voltage on FT_XXX pins	$V_{SS}-0.3$	$\text{Min}(V_{DD}, V_{DDA}, V_{DD33USB}, V_{BAT}) + 4.0^{(3)(4)}$	V
	Input voltage on TT_XX pins	$V_{SS}-0.3$	4.0	V
	Input voltage on BOOT0 pin	$V_{SS}$	9.0	V
	Input voltage on any other pins	$V_{SS}-0.3$	4.0	V
$ \Delta V_{DDX} $	Variations between different $V_{DDX}$ power pins of the same domain	-	50	mV
$ V_{SSx}-V_{SS} $	Variations between all the different ground pins	-	50	mV

1. All main power ( $V_{DD}$ ,  $V_{DDA}$ ,  $V_{DD33USB}$ ,  $V_{BAT}$ ) and ground ( $V_{SS}$ ,  $V_{SSA}$ ) pins must always be connected to the external power supply, in the permitted range.
2.  $V_{IN}$  maximum must always be respected. Refer to [Table 57](#) for the maximum allowed injected current values.



3. This formula has to be applied on power supplies related to the IO structure described by the pin definition table.
4. To sustain a voltage higher than 4V the internal pull-up/pull-down resistors must be disabled.

**Table 20. Current characteristics**

Symbols	Ratings	Max	Unit
$\Sigma IV_{DD}$	Total current into sum of all $V_{DD}$ power lines (source) <sup>(1)</sup>	620	mA
$\Sigma IV_{SS}$	Total current out of sum of all $V_{SS}$ ground lines (sink) <sup>(1)</sup>	620	
$IV_{DD}$	Maximum current into each $V_{DD}$ power pin (source) <sup>(1)</sup>	100	
$IV_{SS}$	Maximum current out of each $V_{SS}$ ground pin (sink) <sup>(1)</sup>	100	
$I_{IO}$	Output current sunk by any I/O and control pin	20	
$\Sigma I_{(PIN)}$	Total output current sunk by sum of all I/Os and control pins <sup>(2)</sup>	140	
	Total output current sourced by sum of all I/Os and control pins <sup>(2)</sup>	140	
$I_{INJ(PIN)}^{(3)(4)}$	Injected current on FT_xxx, TT_xx, RST and B pins except PA4, PA5	-5/+0	
	Injected current on PA4, PA5	-0/0	
$\Sigma I_{INJ(PIN)}$	Total injected current (sum of all I/Os and control pins) <sup>(5)</sup>	±25	

1. All main power ( $V_{DD}$ ,  $V_{DDA}$ ,  $V_{DD33USB}$ ) and ground ( $V_{SS}$ ,  $V_{SSA}$ ) pins must always be connected to the external power supplies, in the permitted range.
2. This current consumption must be correctly distributed over all I/Os and control pins. The total output current must not be sunk/sourced between two consecutive power supply pins referring to high pin count QFP packages.
3. Positive injection is not possible on these I/Os and does not occur for input voltages lower than the specified maximum value.
4. A positive injection is induced by  $V_{IN} > V_{DD}$  while a negative injection is induced by  $V_{IN} < V_{SS}$ .  $I_{INJ(PIN)}$  must never be exceeded. Refer also to [Table 19: Voltage characteristics](#) for the maximum allowed input voltage values.
5. When several inputs are submitted to a current injection, the maximum  $\Sigma I_{INJ(PIN)}$  is the absolute sum of the positive and negative injected currents (instantaneous values).

**Table 21. Thermal characteristics**

Symbol	Ratings	Value	Unit
$T_{STG}$	Storage temperature range	? 65 to +150	°C
$T_J$	Maximum junction temperature	125	

## 6.3 Operating conditions

### 6.3.1 General operating conditions

Table 22. General operating conditions

Symbol	Parameter	Operating conditions	Min	Max	Unit
$V_{DD}$	Standard operating voltage	-	1.62 <sup>(1)</sup>	3.6	V
$V_{DDLDO}$	Supply voltage for the internal regulator	$V_{DDLDO} \leq V_{DD}$	1.62 <sup>(1)</sup>	3.6	
$V_{DD33USB}$	Standard operating voltage, USB domain	USB used	3.0	3.6	
		USB not used	0	3.6	
$V_{DDA}$	Analog operating voltage	ADC or COMP used	1.62	3.6	
		DAC used	1.8		
		OPAMP used	2.0		
		VREFBUF used	1.8		
		ADC, DAC, OPAMP, COMP, VREFBUF not used	0		
$V_{IN}$	I/O Input voltage	TT_xx I/O	-0.3	$V_{DD}+0.3$	
		BOOT0	0	9	
		All I/O except BOOT0 and TT_xx	-0.3	$\text{Min}(V_{DD}, V_{DDA}, V_{DD33USB}) + 3.6V < 5.5V^{(2)(3)}$	
$T_A$	Ambient temperature for the suffix 6 version	Maximum power dissipation	-40	85	°C
		Low-power dissipation <sup>(4)</sup>	-40	105	
$T_J$	Junction temperature range	Suffix 6 version	-40	125	°C

1. When RESET is released functionality is guaranteed down to  $V_{BOR0}$  min
2. This formula has to be applied on power supplies related to the IO structure described by the pin definition table.
3. For operation with voltage higher than  $\text{Min}(V_{DD}, V_{DDA}, V_{DD33USB}) + 0.3V$ , the internal Pull-up and Pull-Down resistors must be disabled.
4. In low-power dissipation state,  $T_A$  can be extended to this range as long as  $T_J$  does not exceed  $T_{Jmax}$  (see [Section 8.6: Thermal characteristics](#)).

### 6.3.2 VCAP external capacitor

Stabilization for the main regulator is achieved by connecting an external capacitor  $C_{EXT}$  to the VCAP pin.  $C_{EXT}$  is specified in [Table 23](#). Two external capacitors can be connected to VCAP pins.

Figure 13. External capacitor  $C_{EXT}$

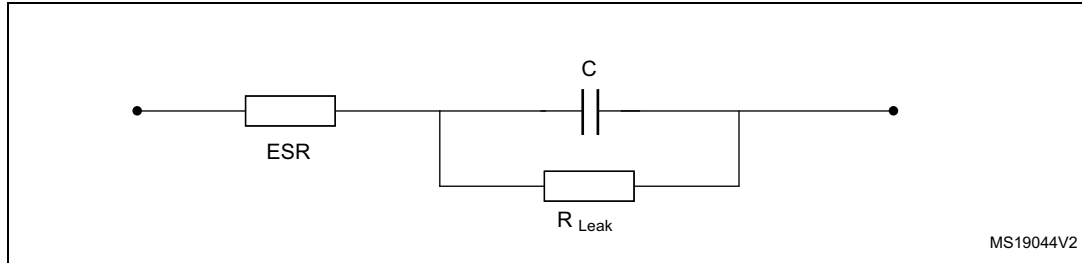

- Legend: ESR is the equivalent series resistance.

Table 23. VCAP operating conditions<sup>(1)</sup>

Symbol	Parameter	Conditions
C <sub>EXT</sub>	Capacitance of external capacitor	2.2 μF <sup>(2)</sup>
ESR	ESR of external capacitor	< 100 mΩ

- When bypassing the voltage regulator, the two 2.2 μF V<sub>CAP</sub> capacitors are not required and should be replaced by two 100 nF decoupling capacitors.
- This value corresponds to C<sub>EXT</sub> typical value. A variation of +/-20% is tolerated.

### 6.3.3 Operating conditions at power-up / power-down

Subject to general operating conditions for T<sub>A</sub>.

Table 24. Operating conditions at power-up / power-down (regulator ON)

Symbol	Parameter	Min	Max	Unit
t <sub>VDD</sub>	V <sub>DD</sub> rise time rate	0	∞	μs/V
	V <sub>DD</sub> fall time rate	10	∞	
t <sub>VDDA</sub>	V <sub>DDA</sub> rise time rate	0	∞	
	V <sub>DDA</sub> fall time rate	10	∞	
t <sub>VDDUSB</sub>	V <sub>DDUSB</sub> rise time rate	0	∞	
	V <sub>DDUSB</sub> fall time rate	10	∞	

### 6.3.4 Embedded reset and power control block characteristics

The parameters given in [Table 25](#) are derived from tests performed under ambient temperature and  $V_{DD}$  supply voltage conditions summarized in [Table 22: General operating conditions](#).

**Table 25. Reset and power control block characteristics**

Symbol	Parameter	Conditions	Min	Typ	Max	Unit
$t_{RSTTEMPO}^{(1)}$	Reset temporization after BOR0 released	-	-	377	-	$\mu\text{s}$
$V_{BOR0}$	Brown-out reset threshold 0	Rising edge <sup>(1)</sup>	1.62	1.67	1.71	V
		Falling edge	1.58	1.62	1.68	
$V_{BOR1}$	Brown-out reset threshold 1	Rising edge	2.04	2.10	2.15	
		Falling edge	1.95	2.00	2.06	
$V_{BOR2}$	Brown-out reset threshold 2	Rising edge	2.34	2.41	2.47	
		Falling edge	2.25	2.31	2.37	
$V_{BOR3}$	Brown-out reset threshold 3	Rising edge	2.63	2.70	2.78	
		Falling edge	2.54	2.61	2.68	
$V_{PVD0}$	Programmable Voltage Detector threshold 0	Rising edge	1.90	1.96	2.01	
		Falling edge	1.81	1.86	1.91	
$V_{PVD1}$	Programmable Voltage Detector threshold 1	Rising edge	2.05	2.10	2.16	
		Falling edge	1.96	2.01	2.06	
$V_{PVD2}$	Programmable Voltage Detector threshold 2	Rising edge	2.19	2.26	2.32	
		Falling edge	2.10	2.15	2.21	
$V_{PVD3}$	Programmable Voltage Detector threshold 3	Rising edge	2.35	2.41	2.47	
		Falling edge	2.25	2.31	2.37	
$V_{PVD4}$	Programmable Voltage Detector threshold 4	Rising edge	2.49	2.56	2.62	
		Falling edge	2.39	2.45	2.51	
$V_{PVD5}$	Programmable Voltage Detector threshold 5	Rising edge	2.64	2.71	2.78	
		Falling edge	2.55	2.61	2.68	
$V_{PVD6}$	Programmable Voltage Detector threshold 6	Rising edge	2.78	2.86	2.94	
		Falling edge in Run mode	2.69	2.76	2.83	
$V_{hyst\_BOR\_PVD}$	Hysteresis voltage of BOR (unless BOR0) and PVD	Hysteresis in Run mode	-	100	-	mV
$I_{DD\_BOR\_PVD}^{(1)}$	BOR <sup>(2)</sup> (unless BOR0) and PVD consumption from $V_{DD}$	-	-		0.630	$\mu\text{A}$

Table 25. Reset and power control block characteristics (continued)

Symbol	Parameter	Conditions	Min	Typ	Max	Unit	
V <sub>AVM_0</sub>	Analog voltage detector for V <sub>DDA</sub> threshold 0	Rising edge	1.66	1.71	1.76	V	
		Falling edge	1.56	1.61	1.66		
V <sub>AVM_1</sub>	Analog voltage detector for V <sub>DDA</sub> threshold 1	Rising edge	2.06	2.12	2.19		
		Falling edge	1.96	2.02	2.08		
V <sub>AVM_2</sub>	Analog voltage detector for V <sub>DDA</sub> threshold 2	Rising edge	2.42	2.50	2.58		
		Falling edge	2.35	2.42	2.49		
V <sub>AVM_3</sub>	Analog voltage detector for V <sub>DDA</sub> threshold 3	Rising edge	2.74	2.83	2.91		
		Falling edge	2.64	2.72	2.80		
V <sub>hyst_VDDA</sub>	Hysteresis of V <sub>DDA</sub> voltage detector	-	-	100	-		mV
I <sub>DD_PVM</sub>	PVM consumption from V <sub>DD</sub> (1)	-	-	-	0.25		μA
I <sub>DD_VDDA</sub>	Voltage detector consumption on V <sub>DDA</sub> (1)	Resistor bridge	-	-	2.5	μA	

1. Guaranteed by design.

2. BOR0 is enabled in all modes and its consumption is therefore included in the supply current characteristics tables (refer to [Section 6.3.6: Supply current characteristics](#)).

### 6.3.5 Embedded reference voltage

The parameters given in [Table 26](#) are derived from tests performed under ambient temperature and V<sub>DD</sub> supply voltage conditions summarized in [Table 22: General operating conditions](#).

Table 26. Embedded reference voltage

Symbol	Parameter	Conditions	Min	Typ	Max	Unit
V <sub>REFINT</sub>	Internal reference voltages	-40°C < T <sub>J</sub> < 105°C, V <sub>DD</sub> = 3.3 V	1.180	1.216	1.255	V
t <sub>S_vrefint</sub> (1)(2)	ADC sampling time when reading the internal reference voltage	-	4.3	-	-	μs
t <sub>S_vbat</sub> (1)(2)	VBAT sampling time when reading the internal VBAT reference voltage	-	9	-	-	
I <sub>refbuf</sub> (2)	Reference Buffer consumption for ADC	V <sub>DDA</sub> =3.3 V	9	13.5	23	μA
ΔV <sub>REFINT</sub> (2)	Internal reference voltage spread over the temperature range	-40°C < T <sub>J</sub> < 105°C	-	5	15	mV
T <sub>coeff</sub> (2)	Average temperature coefficient	Average temperature coefficient	-	20	70	ppm/°C
V <sub>DDcoeff</sub> (2)	Average Voltage coefficient	3.0V < V <sub>DD</sub> < 3.6V	-	10	1370	ppm/V

Table 26. Embedded reference voltage (continued)

Symbol	Parameter	Conditions	Min	Typ	Max	Unit
V <sub>REFINT_DIV1</sub>	1/4 reference voltage	-	-	25	-	% V <sub>REFINT</sub>
V <sub>REFINT_DIV2</sub>	1/2 reference voltage	-	-	50	-	
V <sub>REFINT_DIV3</sub>	3/4 reference voltage	-	-	75	-	

1. The shortest sampling time for the application can be determined by multiple iterations.
2. Guaranteed by design.

Table 27. Internal reference voltage calibration values

Symbol	Parameter	Memory address
V <sub>REFIN_CAL</sub>	Raw data acquired at temperature of 30 °C, V <sub>DDA</sub> = 3.3 V	1FF1E860 - 1FF1E861

### 6.3.6 Supply current characteristics

The current consumption is a function of several parameters and factors such as the operating voltage, ambient temperature, I/O pin loading, device software configuration, operating frequencies, I/O pin switching rate, program location in memory and executed binary code.

The current consumption is measured as described in [Figure 12: Current consumption measurement scheme](#).

All the run-mode current consumption measurements given in this section are performed with a CoreMark code.

#### Typical and maximum current consumption

The MCU is placed under the following conditions:

- All I/O pins are in analog input mode.
- All peripherals are disabled except when explicitly mentioned.
- The Flash memory access time is adjusted with the minimum wait states number, depending on the  $f_{\text{ACLK}}$  frequency (refer to the table “Number of wait states according to CPU clock ( $f_{\text{rcc\_c\_ck}}$ ) frequency and V<sub>CORE</sub> range” available in the reference manual).
- When the peripherals are enabled, the AHB clock frequency is the CPU frequency divided by 2 and the APB clock frequency is AHB clock frequency divided by 2.

The parameters given in [Table 28](#) to [Table 36](#) are derived from tests performed under ambient temperature and supply voltage conditions summarized in [Table 22: General operating conditions](#).

**Table 28. Typical and maximum current consumption in Run mode, code with data processing running from ITCM, regulator ON<sup>(1)</sup>**

Symbol	Parameter	Conditions	f <sub>rcc_c_ck</sub> (MHz)	Typ	Max <sup>(2)</sup>				unit	
					T <sub>J</sub> = 25°C	T <sub>J</sub> = 85°C	T <sub>J</sub> = 105°C	T <sub>J</sub> = 125°C		
I <sub>DD</sub>	Supply current in Run mode	All peripherals disabled	VOS1	400	71	110	210	290	540	mA
				300	56	-	-	-	-	
			VOS2	300	50	72	170	230	370	
				216	37	58	150	210	380	
			VOS3	200	35.5	-	-	-	-	
				200	33	50	130	190	300	
				180	30	47	130	180	290	
				168	28	45	130	180	290	
				144	25	41	120	180	290	
		60		13	28	110	160	280		
		All peripherals enabled	VOS1	25	10	24	99	160	270	
				400	165	220 <sup>(3)</sup>	400	500 <sup>(3)</sup>	840	
			VOS2	300	130	-	-	-	-	
				300	120	170	300	390	570	
			VOS3	200	83	-	-	-	-	
				200	78	110	220	300	470	

1. Data are in DTCM for best computation performance, cache has no influence on consumption in this case.
2. Guaranteed by characterization results unless otherwise specified.
3. Guaranteed by test in production.

**Table 29. Typical and maximum current consumption in Run mode, code with data processing running from Flash memory, cache ON, regulator ON**

Symbol	Parameter	Conditions	f <sub>rcc_c_ck</sub> (MHz)	Typ	Max <sup>(1)</sup>				unit	
					T <sub>J</sub> = 25°C	T <sub>J</sub> = 85°C	T <sub>J</sub> = 105°C	T <sub>J</sub> = 125°C		
I <sub>DD</sub>	Supply current in Run mode	All peripherals disabled	VOS1	400	105	160	310	420	750	mA
				300	55	-	-	-	-	
			VOS2	300	50	72	160	230	370	
				216	38	-	-	-	-	
			VOS3	200	36	-	-	-	-	
				200	33	50	130	190	300	
				180	30	-	-	-	-	
				168	29	-	-	-	-	
				144	26	-	-	-	-	
		60	14	-	-	-	-			
		25	14	-	-	-	-			
		All peripherals enabled	VOS1	400	160	220	400	500	750	
				300	130	-	-	-	-	
			VOS2	300	120	160	300	390	560	
				200	81	-	-	-	-	
			VOS3	200	77	110	220	300	460	

1. Guaranteed by characterization results unless otherwise specified.

**Table 30. Typical and maximum current consumption in Run mode, code with data processing running from Flash memory, cache OFF, regulator ON**

Symbol	Parameter	Conditions	f <sub>rcc_c_ck</sub> (MHz)	Typ	Max <sup>(1)</sup>				unit	
					T <sub>J</sub> = 25°C	T <sub>J</sub> = 85°C	T <sub>J</sub> = 105°C	T <sub>J</sub> = 125°C		
I <sub>DD</sub>	Supply current in Run mode	All peripherals disabled	VOS1	400	73	110	220	290	540	mA
			VOS2	300	52	75	170	230	370	
			VOS3	200	34	52	130	190	300	
		All peripherals enabled	VOS1	400	135	190	360	470	730	
			VOS2	300	100	150	270	370	550	
			VOS3	200	70	100	210	300	460	

1. Guaranteed by characterization results.



**Table 31. Typical consumption in Run mode and corresponding performance versus code position**

Symbol	Parameter	Conditions		f <sub>rcc_ck</sub> (MHz)	CoreMark	Typ	Unit	IDD/ CoreMark	Unit
		Peripheral	Code						
I <sub>DD</sub>	Supply current in Run mode	All peripherals disabled, cache ON	ITCM	400	2012	71	mA	35	μA/ CoreMark
			FLASH A	400	2012	105		52	
			AXI SRAM	400	2012	105		52	
			SRAM1	400	2012	105		52	
			SRAM4	400	2012	105		52	
		All peripherals disabled cache OFF	ITCM	400	2012	71		35	
			FLASH A	400	593	70.5		119	
			AXI SRAM	400	344	70.5		205	
			SRAM1	400	472	74.5		158	
			SRAM4	400	432	72		167	

**Table 32. Typical current consumption batch acquisition mode**

Symbol	Parameter	Conditions	f <sub>rcc_ahb_ck(AHB4)</sub> (MHz)	Typ	unit
I <sub>DD</sub>	Supply current in batch acquisition mode	D1Standby, D2Standby, D3Run	VOS3	64	6.5
		D1Stop, D2Stop, D3Run	VOS3	64	12

**Table 33. Typical and maximum current consumption in Sleep mode, regulator ON**

Symbol	Parameter	Conditions	f <sub>rcc_ck</sub> (MHz)	Typ	Max <sup>(1)</sup>				unit	
					T <sub>J</sub> = 25°C	T <sub>J</sub> = 85°C	T <sub>J</sub> = 105°C	T <sub>J</sub> = 125°C		
I <sub>DD(Sleep)</sub>	Supply current in Sleep mode	All peripherals disabled	VOS1	400	31.0	64	220	330	660	mA
				300	24.5	57	210	330	650	
			VOS2	300	22.0	48	180	270	500	
				200	17.0	42	170	270	490	
			VOS3	200	15.5	37	150	230	400	

1. Guaranteed by characterization results.

**Table 34. Typical and maximum current consumption in Stop mode, regulator ON**

Symbol	Parameter	Conditions	Typ	Max <sup>(1)</sup>				unit	
				T <sub>J</sub> = 25°C	T <sub>J</sub> = 85°C	T <sub>J</sub> = 105°C	T <sub>J</sub> = 125°C		
I <sub>DD(Stop)</sub>	D1Stop, D2Stop, D3Stop	Flash memory in low-power mode, no IWDG	SVOS5	1.4	7.2 <sup>(2)</sup>	49	75 <sup>(2)</sup>	140	mA
			SVOS4	1.95	11	66	110	200	
			SVOS3	2.85	16 <sup>(2)</sup>	91	150 <sup>(2)</sup>	240	
		Flash memory ON, no IWDG	SVOS5	1.65	7.2	49	75	140	
			SVOS4	2.2	11	66	110	180	
			SVOS3	3.15	16	91	150	300	
	D1Stop, D2Standby, D3Stop	Flash memory OFF, no IWDG	SVOS5	0.99	5.1	35	60	97	
			SVOS4	1.4	7.5	47	79	130	
			SVOS3	2.05	12	64	110	170	
		Flash memory ON, no IWDG	SVOS5	1.25	5.5	35	61	98	
			SVOS4	1.65	7.8	47	80	130	
			SVOS3	2.3	12	65	110	170	
	D1Standby, D2Stop, D3Stop	Flash OFF, no IWDG	SVOS5	0.57	3	21	36	57	
			SVOS4	0.805	4.5	27	47	74	
			SVOS3	1.2	6.7	37	63	99	
			SVOS5	0.17	1.1 <sup>(2)</sup>	8	13 <sup>(2)</sup>	20	
	D1Standby, D2Standby, D3Stop	Flash OFF, no IWDG	SVOS4	0.245	1.5	11	17	26	
			SVOS3	0.405	2.4 <sup>(2)</sup>	15	23 <sup>(2)</sup>	35	

1. Guaranteed by characterization results.
2. Guaranteed by test in production.

**Table 35. Typical and maximum current consumption in Standby mode**

Symbol	Parameter	Conditions		Typ <sup>(3)</sup>				Max (3 V) <sup>(1)</sup>				Unit
		Backup SRAM	RTC & LSE	1.62 V	2.4 V	3 V	3.3 V	T <sub>J</sub> = 25°C	T <sub>J</sub> = 85°C	T <sub>J</sub> = 105°C	T <sub>J</sub> = 125°C	
I <sub>DD</sub> (Standby)	Supply current in Standby mode	OFF	OFF	1.8	1.9	1.95	2.05	4 <sup>(2)</sup>	18 <sup>(3)</sup>	40 <sup>(2)</sup>	90 <sup>(3)</sup>	μA
		ON	OFF	3.4	3.4	3.5	3.7	8.2 <sup>(3)</sup>	47 <sup>(3)</sup>	83 <sup>(3)</sup>	141 <sup>(3)</sup>	
		OFF	ON	2.4	3.5	3.86	4.12	-	-	-	-	
		ON	ON	3.95	5.1	5.46	5.97	-	-	-	-	

1. The maximum current consumption values are given for PDR OFF (internal reset OFF). When the PDR is OFF (internal reset OFF), the current consumption is reduced by 1.2 μA compared to PDR ON.
2. Guaranteed by test in production.
3. Guaranteed by characterization results.

Table 36. Typical and maximum current consumption in VBAT mode

Symbol	Parameter	Conditions		Typ <sup>(1)</sup>				Max (3 V)				Unit
		Backup SRAM	RTC & LSE	1.2 V	2 V	3 V	3.4 V	T <sub>J</sub> = 25°C	T <sub>J</sub> = 85°C	T <sub>J</sub> = 105°C	T <sub>J</sub> = 125°C	
I <sub>DD</sub> (VBAT)	Supply current in standby mode	OFF	OFF	0.024	0.035	0.062	0.096	0.5 <sup>(1)</sup>	4.1 <sup>(1)</sup>	10 <sup>(1)</sup>	24 <sup>(1)</sup>	μA
		ON	OFF	1.4	1.6	1.8	1.8	4.4 <sup>(1)</sup>	22 <sup>(1)</sup>	48 <sup>(1)</sup>	87 <sup>(1)</sup>	
		OFF	ON	0.24	0.45	0.62	0.73	-	-	-	-	
		ON	ON	1.97	2.37	2.57	2.77	-	-	-	-	

1. Guaranteed by characterization results.

## I/O system current consumption

The current consumption of the I/O system has two components: static and dynamic.

### I/O static current consumption

All the I/Os used as inputs with pull-up generate a current consumption when the pin is externally held low. The value of this current consumption can be simply computed by using the pull-up/pull-down resistors values given in [Table 58: I/O static characteristics](#).

For the output pins, any external pull-down or external load must also be considered to estimate the current consumption.

An additional I/O current consumption is due to I/Os configured as inputs if an intermediate voltage level is externally applied. This current consumption is caused by the input Schmitt trigger circuits used to discriminate the input value. Unless this specific configuration is required by the application, this supply current consumption can be avoided by configuring these I/Os in analog mode. This is notably the case of ADC input pins which should be configured as analog inputs.

**Caution:** Any floating input pin can also settle to an intermediate voltage level or switch inadvertently, as a result of external electromagnetic noise. To avoid a current consumption related to floating pins, they must either be configured in analog mode, or forced internally to a definite digital value. This can be done either by using pull-up/down resistors or by configuring the pins in output mode.

### I/O dynamic current consumption

In addition to the internal peripheral current consumption (see [Table 37: Peripheral current consumption in Run mode](#)), the I/Os used by an application also contribute to the current consumption. When an I/O pin switches, it uses the current from the MCU supply voltage to supply the I/O pin circuitry and to charge/discharge the capacitive load (internal or external) connected to the pin:

$$I_{SW} = V_{DDx} \times f_{SW} \times C_L$$

where

$I_{SW}$  is the current sunk by a switching I/O to charge/discharge the capacitive load

$V_{DDx}$  is the MCU supply voltage

$f_{SW}$  is the I/O switching frequency

$C_L$  is the total capacitance seen by the I/O pin:  $C = C_{INT} + C_{EXT}$

The test pin is configured in push-pull output mode and is toggled by software at a fixed frequency.

### On-chip peripheral current consumption

The MCU is placed under the following conditions:

- At startup, all I/O pins are in analog input configuration.
- All peripherals are disabled unless otherwise mentioned.
- The I/O compensation cell is enabled.
- $f_{\text{rcc\_c\_ck}}$  is the CPU clock.  $f_{\text{PCLK}} = f_{\text{rcc\_c\_ck}}/4$ , and  $f_{\text{HCLK}} = f_{\text{rcc\_c\_ck}}/2$ .  
The given value is calculated by measuring the difference of current consumption
  - with all peripherals clocked off
  - with only one peripheral clocked on
  - $f_{\text{rcc\_c\_ck}} = 400$  MHz (Scale 1),  $f_{\text{rcc\_c\_ck}} = 300$  MHz (Scale 2),  
 $f_{\text{rcc\_c\_ck}} = 200$  MHz (Scale 3)
- The ambient operating temperature is 25 °C and  $V_{\text{DD}}=3.3$  V.

Table 37. Peripheral current consumption in Run mode

Peripheral		I <sub>DD</sub> (Typ)			Unit
		VOS1	VOS2	VOS3	
AHB3	MDMA	8.3	7.6	7	μA/MHz
	DMA2D	21	20	18	
	JPEG	24	23	21	
	FLASH	9.9	9	8.3	
	FMC registers	0.9	0.9	0.8	
	FMC kernel	6.1	5.5	5.3	
	QUADSPI registers	1.5	1.4	1.3	
	QUADSPI kernel	0.9	0.8	0.7	
	SDMMC1 registers	8	7.2	6.8	
	SDMMC1 kernel	2.4	2	1.8	
	DTCM1	5.7	5	4.5	
	DTCM2	5.5	4.8	4.3	
	ITCM	3.2	2.9	2.6	
	D1SRAM1	7.6	6.8	6.1	
AHB3 bridge	7.5	6.8	6.3		
AHB1	DMA1	1.1	1	1	
	DMA2	1.7	1.4	1.1	
	ADC1/2 registers	3.9	3.2	3.1	
	ADC1/2 kernel	0.9	0.8	0.7	
	ART accelerator	5.5	4.5	4.2	
	ETH1MAC	16	14	13	
	ETH1TX				
	ETH1RX				
	USB1 OTG registers	15	14	13	
	USB1 OTG kernel	-	8.5	8.5	
	USB1 ULPI	0.3	0.3	0.1	
	USB2 OTG registers	15	13	12	
	USB2 OTG kernel	-	8.6	8.6	
	USB2 ULPI	16	16	16	
AHB1 Bridge	10	9.6	8.6		

**Table 37. Peripheral current consumption in Run mode (continued)**

Peripheral		I <sub>DD</sub> (Typ)			Unit
		VOS1	VOS2	VOS3	
AHB2	DCMI	1.7	1.7	1.7	μA/MHz
	CRYP	0.1	0.1	0.1	
	HASH	0.1	0.1	0.1	
	RNG registers	1.8	1.4	1.2	
	RNG kernel	-	9.6	9.6	
	SDMMC2 registers	13	12	11	
	SDMMC2 kernel	2.7	2.5	2.4	
	D2SRAM1	3.3	3.1	2.8	
	D2SRAM2	2.9	2.7	2.5	
	D2SRAM3	1.9	1.8	1.7	
AHB2 bridge	0.1	0.1	0.1		
AHB4	GPIOA	1.1	1	0.9	
	GPIOB	1	0.9	0.9	
	GPIOC	1.4	1.3	1.3	
	GIOD	1.1	1	0.9	
	GPIOE	1	0.9	0.8	
	GPIOF	0.9	0.8	0.8	
	GPIOG	0.9	0.7	0.7	
	GPIOH	1	0.9	0.9	
	GPIOI	0.9	0.9	0.8	
	GPIOJ	0.9	0.8	0.8	
	GPIOK	0.9	0.8	0.7	
	CRC	0.5	0.4	0.4	
	BDMA	6.2	5.8	5.5	
	ADC3 registers	1.8	1.7	1.7	
	ADC3 kernel	0.1	0.1	0.1	
	Backup SRAM	1.9	1.8	1.8	
	Bridge AHB4	0.1	0.1	0.1	
APB3	LCD-TFT	12	11	10	μA/MHz
	WWDG1	0.5	0.4	0.3	
	APB3 bridge	0.5	0.2	0.1	

Table 37. Peripheral current consumption in Run mode (continued)

Peripheral		I <sub>DD</sub> (Typ)			Unit
		VOS1	VOS2	VOS3	
APB1	TIM2	3.5	3.2	2.9	μA/MHz
	TIM3	3.4	3.1	2.7	
	TIM4	2.7	2.5	1.9	
	TIM5	3.2	2.9	2.5	
	TIM6	1	0.8	0.7	
	TIM7	1	0.9	0.7	
	TIM12	1.7	1.5	1.2	
	TIM13	1.5	1.3	1	
	TIM14	1.4	1.3	0.9	
	LPTIM1 registers	0.7	0.6	0.5	
	LPTIM1 kernel	2.3	2.1	1.9	
	WWDG2	0.6	0.4	0.4	
	SPI2 registers	1.8	1.5	1.2	
	SPI2 kernel	0.6	0.5	0.5	
	SPI3 registers	1.5	1.3	1.1	
	SPI3 kernel	0.6	0.5	0.5	
	SPDIFRX1 registers	0.6	0.5	0.3	
	SPDIFRX1 kernel	2.9	2.4	2.4	
	USART2 registers	1.4	1.3	1	
	USART2 kernel	4.7	4.1	4	
USART3 registers	1.4	1.3	1		
USART3 kernel	4.2	3.8	3.5		
UART4 registers	1.5	1.1	1		
UART4 kernel	3.7	3.6	3.2		

**Table 37. Peripheral current consumption in Run mode (continued)**

Peripheral		I <sub>DD</sub> (Typ)			Unit
		VOS1	VOS2	VOS3	
APB1 (continued)	UART5 registers	1.4	1.4	1	μA/MHz
	UART5 kernel	3.6	3.2	3.1	
	I2C1 registers	0.8	0.8	0.6	
	I2C1 kernel	2	1.8	1.7	
	I2C2 registers	0.7	0.7	0.4	
	I2C2 kernel	1.9	1.7	1.6	
	I2C3 registers	0.9	0.7	0.6	
	I2C3 kernel	2.1	1.9	1.9	
	HDMI-CEC registers	0.5	0.3	0.3	
	DAC1/2	1.4	1.1	0.9	
	USART7 registers	1.9	1.8	1.3	
	USART7 kernel	4	3.5	3.3	
	USART8 registers	1.6	1.5	1.2	
	USART8 kernel	4	3.6	3.3	
	CRS	3.4	3.1	2.9	
	SWPMI registers	2.3	2	2	
	SWPMI kernel	0.1	0.1	0.1	
	OPAMP	0.5	0.4	0.4	
	MDIO	2.7	2.4	2.3	
	FDCAN registers	16	15	14	
FDCAN kernel	7.8	7.6	7.1		
Bridge APB1	0.1	0.1	0.1		



**Table 37. Peripheral current consumption in Run mode (continued)**

Peripheral		I <sub>DD</sub> (Typ)			Unit
		VOS1	VOS2	VOS3	
APB2	TIM1	5.1	4.8	4.3	μA/MHz
	TIM8	5.4	4.9	4.6	
	USART1 registers	2.7	2.6	2.5	
	USART1 kernel	0.1	0.1	0.1	
	USART6 registers	2.6	2.5	2.5	
	USART6 kernel	0.1	0.1	0.1	
	SPI1 registers	1.8	1.6	1.6	
	SPI1 kernel	1	0.8	0.6	
	SPI4 registers	1.6	1.5	1.5	
	SPI4 kernel	0.5	0.4	0.4	
	TIM15	3.1	2.8	2.7	
	TIM16	2.4	2.1	2.1	
	TIM17	2.2	2	1.9	
	SPI5 registers	1.8	1.7	1.7	
	SPI5 kernel	0.6	0.5	0.3	
	SAI1 registers	1.5	1.4	1.4	
	SAI1 kernel	2	1.7	1.5	
	SAI2 registers	1.5	1.5	1.3	
	SAI2 kernel	2.2	1.9	1.8	
	SAI3 registers	1.8	1.6	1.6	
	SAI3 kernel	2.5	2.3	2.1	
	DFSDM1 registers	6	5.4	5.2	
	DFSDM1 kernel	0.9	0.8	0.7	
	HRTIM	40	37	35	
Bridge APB2	0.1	0.1	0.1		

**Table 37. Peripheral current consumption in Run mode (continued)**

Peripheral		I <sub>DD</sub> (Typ)			Unit
		VOS1	VOS2	VOS3	
APB4	SYSCFG	1	0.7	0.7	μA/MHz
	LPUART1 registers	1.1	1.1	1.1	
	LPUART1 kernel	2.6	2.4	2.1	
	SPI6 registers	1.6	1.5	1.4	
	SPI6 kernel	0.2	0.2	0.2	
	I2C4 registers	0.1	0.1	0.1	
	I2C4 kernel	2.4	2.1	2	
	LPTIM2 registers	0.5	0.5	0.5	
	LPTIM2 kernel	2.3	2.1	1.8	
	LPTIM3 registers	0.5	0.5	0.5	
	LPTIM3 kernel	2	2.1	1.5	
	LPTIM4 registers	0.5	0.5	0.5	
	LPTIM4 kernel	2	2	1.9	
	LPTIM5 registers	0.5	0.5	0.5	
	LPTIM5 kernel	2	1.8	1.5	
	COMP1/2	0.7	0.5	0.5	
	VREFBUF	0.6	0.4	0.4	
	RTC	1.2	1.1	1.1	
	SAI4 registers	1.6	1.5	1.4	
	SAI4 kernel	1.3	1.3	1.2	
Bridge APB4	0.1	0.1	0.1		

**Table 38. Peripheral current consumption in Stop, Standby and VBAT mode**

Symbol	Parameter	Conditions	Typ	Unit
			3 V	
I <sub>DD</sub>	RTC+LSE low drive	-	2.32	μA
	RTC+LSE medium-low drive	-	2.4	
	RTC+LSE medium-high drive	-	2.7	
	RTC+LSE High drive	-	3	

### 6.3.7 Wakeup time from low-power modes

The wakeup times given in [Table 39](#) are measured starting from the wakeup event trigger up to the first instruction executed by the CPU:

- For Stop or Sleep modes: the wakeup event is WFE.
- WKUP (PC1) pin is used to wakeup from Standby, Stop and Sleep modes.

All timings are derived from tests performed under ambient temperature and  $V_{DD}=3.3$  V.

**Table 39. Low-power mode wakeup timings**

Symbol	Parameter	Conditions	Typ <sup>(1)</sup>	Max <sup>(1)</sup>	Unit
$t_{WUSLEEP}^{(2)}$	Wakeup from Sleep	-	9	10	CPU clock cycles
$t_{WUSTOP}^{(2)}$	Wakeup from Stop	VOS3, HSI, Flash memory in normal mode	4.4	5.6	$\mu$ s
		VOS3, HSI, Flash memory in low-power mode	12	15	
		VOS4, HSI, Flash memory in normal mode	15	20	
		VOS4, HSI, Flash memory in low-power mode	23	28	
		VOS5, HSI, Flash memory in normal mode	30	71	
		VOS5, HSI, Flash memory in low-power mode	38	47	
		VOS3, CSI, Flash memory in normal mode	27	37	
		VOS3, CSI, Flash memory in low power mode	36	50	
		VOS4, CSI, Flash memory in normal mode	38	48	
		VOS4, CSI, Flash memory in low-power mode	47	61	
		VOS5, CSI, Flash memory in normal mode	52	64	
		VOS5, CSI, Flash memory in low-power mode	62	77	
$t_{WUSTOP2}^{(2)}$	Wakeup from Stop, clock kept running	VOS3, HSI, Flash memory in normal mode	2.6	3.4	$\mu$ s
		VOS3, CSI, Flash memory in normal mode	26	36	
$t_{WUSTDBY}^{(2)}$	Wakeup from Standby mode	-	390	500	$\mu$ s

1. Guaranteed by characterization results.

2. The wakeup times are measured from the wakeup event to the point in which the application code reads the first instruction.

### 6.3.8 External clock source characteristics

#### High-speed external user clock generated from an external source

In bypass mode the HSE oscillator is switched off and the input pin is a standard I/O.

The external clock signal has to respect the [Table 58: I/O static characteristics](#). However, the recommended clock input waveform is shown in [Figure 14](#).

**Table 40. High-speed external user clock characteristics<sup>(1)</sup>**

Symbol	Parameter	Min	Typ	Max	Unit
$f_{HSE\_ext}$	User external clock source frequency	4	25	50	MHz
$V_{SW}$ ( $V_{HSEH}$ ? $V_{HSEL}$ )	OSC_IN amplitude	$0.7V_{DD}$	-	$V_{DD}$	V
$V_{DC}$	OSC_IN input voltage	$V_{SS}$	-	$0.3V_{SS}$	
$t_{W(HSE)}$	OSC_IN high or low time	7	-	-	ns

1. Guaranteed by design.

**Figure 14. High-speed external clock source AC timing diagram**

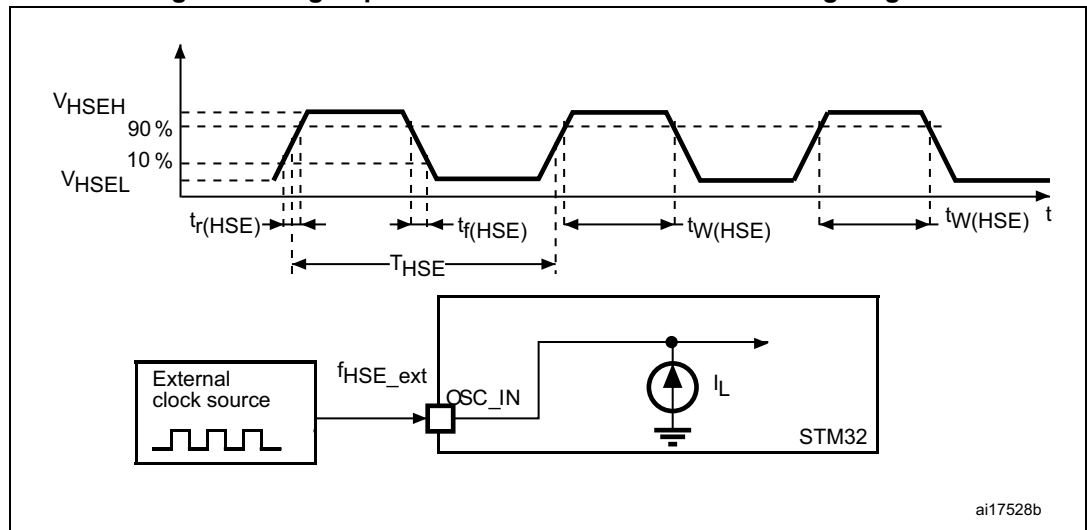

**Low-speed external user clock generated from an external source**

In bypass mode the LSE oscillator is switched off and the input pin is a standard I/O. The external clock signal has to respect the [Table 58: I/O static characteristics](#). However, the recommended clock input waveform is shown in [Figure 15](#).

**Table 41. Low-speed external user clock characteristics<sup>(1)</sup>**

Symbol	Parameter	Conditions	Min	Typ	Max	Unit
$f_{LSE\_ext}$	User external clock source frequency	-	-	32.768	1000	kHz
$V_{LSEH}$	OSC32_IN input pin high level voltage	-	$0.7 V_{DDIOx}$	-	$V_{DDIOx}$	V
$V_{LSEL}$	OSC32_IN input pin low level voltage	-	$V_{SS}$	-	$0.3 V_{DDIOx}$	
$t_{w(LSEH)}$ $t_{w(LSEL)}$	OSC32_IN high or low time	-	250	-	-	ns

1. Guaranteed by design.

**Note:** For information on selecting the crystal, refer to the application note AN2867 “Oscillator design guide for ST microcontrollers” available from the ST website [www.st.com](http://www.st.com).

**Figure 15. Low-speed external clock source AC timing diagram**

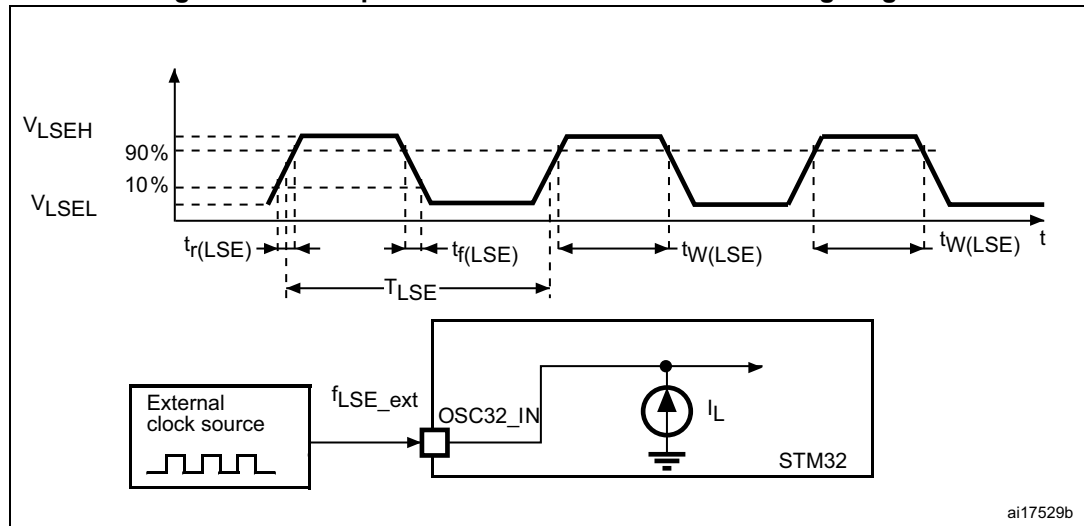

### High-speed external clock generated from a crystal/ceramic resonator

The high-speed external (HSE) clock can be supplied with a 4 to 48 MHz crystal/ceramic resonator oscillator. All the information given in this paragraph are based on characterization results obtained with typical external components specified in [Table 42](#). In the application, the resonator and the load capacitors have to be placed as close as possible to the oscillator pins in order to minimize output distortion and startup stabilization time. Refer to the crystal resonator manufacturer for more details on the resonator characteristics (frequency, package, accuracy).

**Table 42. 4-48 MHz HSE oscillator characteristics<sup>(1)</sup>**

Symbol	Parameter	Operating conditions <sup>(2)</sup>	Min	Typ	Max	Unit
F	Oscillator frequency	-	4	-	48	MHz
R <sub>F</sub>	Feedback resistor	-	-	200	-	kΩ
I <sub>DD(HSE)</sub>	HSE current consumption	During startup <sup>(3)</sup>	-	-	4	mA
		V <sub>DD</sub> =3 V, R <sub>m</sub> =30 Ω C <sub>L</sub> =10pF@4MHz	-	0.35	-	
		V <sub>DD</sub> =3 V, R <sub>m</sub> =30 Ω C <sub>L</sub> =10 pF at 8 MHz	-	0.40	-	
		V <sub>DD</sub> =3 V, R <sub>m</sub> =30 Ω C <sub>L</sub> =10 pF at 16 MHz	-	0.45	-	
		V <sub>DD</sub> =3 V, R <sub>m</sub> =30 Ω C <sub>L</sub> =10 pF at 32 MHz	-	0.65	-	
		V <sub>DD</sub> =3 V, R <sub>m</sub> =30 Ω C <sub>L</sub> =10 pF at 48 MHz	-	0.95	-	
G <sub>m</sub> <sub>critmax</sub>	Maximum critical crystal gm	Startup	-	-	1.5	mA/V
t <sub>SU</sub> <sup>(4)</sup>	Start-up time	V <sub>DD</sub> is stabilized	-	2	-	ms

1. Guaranteed by design.
2. Resonator characteristics given by the crystal/ceramic resonator manufacturer.
3. This consumption level occurs during the first 2/3 of the t<sub>SU(HSE)</sub> startup time.
4. t<sub>SU(HSE)</sub> is the startup time measured from the moment it is enabled (by software) to a stabilized 8 MHz oscillation is reached. This value is measured for a standard crystal resonator and it can vary significantly with the crystal manufacturer.

For C<sub>L1</sub> and C<sub>L2</sub>, it is recommended to use high-quality external ceramic capacitors in the 5 pF to 25 pF range (typical), designed for high-frequency applications, and selected to match the requirements of the crystal or resonator (see [Figure 16](#)). C<sub>L1</sub> and C<sub>L2</sub> are usually the same size. The crystal manufacturer typically specifies a load capacitance which is the series combination of C<sub>L1</sub> and C<sub>L2</sub>. The PCB and MCU pin capacitance must be included (10 pF can be used as a rough estimate of the combined pin and board capacitance) when sizing C<sub>L1</sub> and C<sub>L2</sub>.

**Note:** For information on selecting the crystal, refer to the application note AN2867 “Oscillator design guide for ST microcontrollers” available from the ST website [www.st.com](http://www.st.com).

Figure 16. Typical application with an 8 MHz crystal

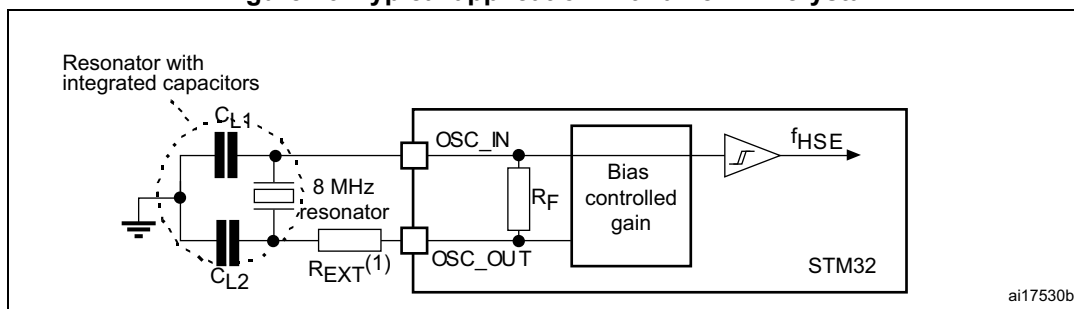

1. R<sub>EXT</sub> value depends on the crystal characteristics.

### Low-speed external clock generated from a crystal/ceramic resonator

The low-speed external (LSE) clock can be supplied with a 32.768 kHz crystal/ceramic resonator oscillator. All the information given in this paragraph are based on characterization results obtained with typical external components specified in [Table 43](#). In the application, the resonator and the load capacitors have to be placed as close as possible to the oscillator pins in order to minimize output distortion and startup stabilization time. Refer to the crystal resonator manufacturer for more details on the resonator characteristics (frequency, package, accuracy).

Table 43. Low-speed external user clock characteristics<sup>(1)</sup>

Symbol	Parameter	Operating conditions <sup>(2)</sup>	Min	Typ	Max	Unit
F	Oscillator frequency	-	-	32.768	-	kHz
I <sub>DD</sub>	LSE current consumption	LSEDRV[1:0] = 00, Low drive capability	-	290	-	nA
		LSEDRV[1:0] = 01, Medium Low drive capability	-	390	-	
		LSEDRV[1:0] = 10, Medium high drive capability	-	550	-	
		LSEDRV[1:0] = 11, High drive capability	-	900	-	
G <sub>m</sub> <sub>critmax</sub>	Maximum critical crystal gm	LSEDRV[1:0] = 00, Low drive capability	-	-	0.5	μA/V
		LSEDRV[1:0] = 01, Medium Low drive capability	-	-	0.75	
		LSEDRV[1:0] = 10, Medium high drive capability	-	-	1.7	
		LSEDRV[1:0] = 11, High drive capability	-	-	2.7	
t <sub>SU</sub> <sup>(3)</sup>	Startup time	VDD is stabilized	-	2	-	s

1. Guaranteed by design.

- Refer to the note and caution paragraphs below the table, and to the application note AN2867 “Oscillator design guide for ST microcontrollers.
- $t_{SU}$  is the startup time measured from the moment it is enabled (by software) to a stabilized 32.768 kHz oscillation is reached. This value is measured for a standard crystal resonator and it can vary significantly with the crystal manufacturer.

**Note:** For information on selecting the crystal, refer to the application note AN2867 “Oscillator design guide for ST microcontrollers” available from the ST website [www.st.com](http://www.st.com).

**Figure 17. Typical application with a 32.768 kHz crystal**

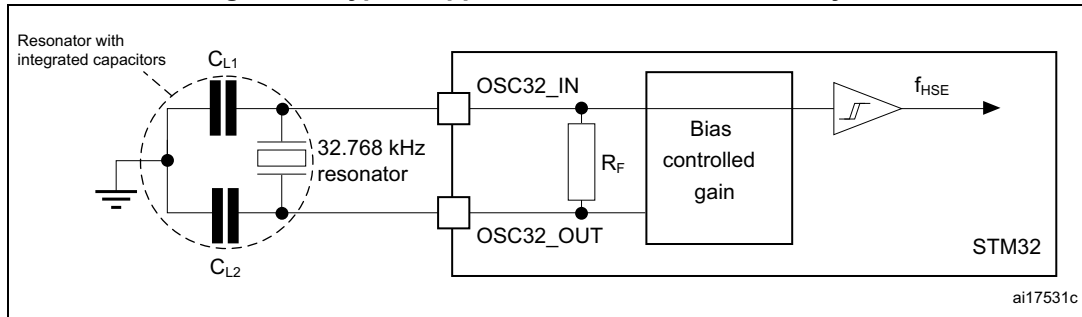

- An external resistor is not required between OSC32\_IN and OSC32\_OUT and it is forbidden to add one.

### 6.3.9 Internal clock source characteristics

The parameters given in [Table 44](#) and [Table 47](#) are derived from tests performed under ambient temperature and  $V_{DD}$  supply voltage conditions summarized in [Table 22: General operating conditions](#).

#### 48 MHz high-speed internal RC oscillator (HSI48)

**Table 44. HSI48 oscillator characteristics**

Symbol	Parameter	Conditions	Min	Typ	Max	Unit
$f_{HSI48}$	HSI48 frequency	$V_{DD}=3.3\text{ V}$ , $T_J=30\text{ °C}$	47.5 <sup>(1)</sup>	48	48.5 <sup>(1)</sup>	MHz
TRIM <sup>(2)</sup>	USER trimming step	-	-	0.17	-	%
USER TRIM COVERAGE <sup>(3)</sup>	USER TRIMMING Coverage	$\pm 32$ steps	-	$\pm 5.45$	-	%
DuCy(HSI48) <sup>(2)</sup>	Duty Cycle	-	45	-	55	%
ACCHSI48_REL <sup>(3)</sup>	Accuracy of the HSI48 oscillator over temperature (factory calibrated)	$V_{DD}=1.62\text{ to }3.6\text{ V}$ , $T_J=-40\text{ to }125\text{ °C}$	-4.5	-	3.5	%
$\Delta V_{DD}(\text{HSI48})$ <sup>(3)</sup>	HSI48 oscillator frequency drift with $V_{DD}$ <sup>(4)</sup>	$V_{DD}=3\text{ to }3.6\text{ V}$	-	0.025	0.05	%
		$V_{DD}=1.62\text{ V to }3.6\text{ V}$	-	0.05	0.1	
$t_{su}(\text{HSI48})$ <sup>(2)</sup>	HSI48 oscillator start-up time	-	-	2.1	3.5	$\mu\text{s}$
$I_{DD}(\text{HSI48})$ <sup>(2)</sup>	HSI48 oscillator power consumption	-	-	350	400	$\mu\text{A}$
$N_T$ jitter	Next transition jitter Accumulated jitter on 28 cycles <sup>(5)</sup>	-	-	$\pm 0.15$	-	ns
$P_T$ jitter	Paired transition jitter Accumulated jitter on 56 cycles <sup>(5)</sup>	-	-	$\pm 0.25$	-	ns



1. Guaranteed by test in production.
2. Guaranteed by design.
3. Guaranteed by characterization.
4. These values are obtained by using the formula:  
(Freq(3.6V) - Freq(3.0V)) / Freq(3.0V) or (Freq(3.6V) - Freq(1.62V)) / Freq(1.62V).
5. Jitter measurements are performed without clock source activated in parallel.

### 64 MHz high-speed internal RC oscillator (HSI)

Table 45. HSI oscillator characteristics<sup>(1)</sup>

Symbol	Parameter	Conditions	Min	Typ	Max	Unit
f <sub>HSI</sub>	HSI frequency	V <sub>DD</sub> =3.3 V, T <sub>J</sub> =30 °C	63.7 <sup>(2)</sup>	64	64.3 <sup>(2)</sup>	MHz
TRIM	HSI user trimming step	Trimming is not a multiple of 32	-	0.24	0.32	%
		Trimming is 128, 256 and 384	-5.2	-1.8	-	
		Trimming is 64, 192, 320 and 448	-1.4	-0.8	-	
		Other trimming are a multiple of 32 (not including multiple of 64 and 128)	-0.6	-0.25	-	
DuCy(HSI)	Duty Cycle	-	45	-	55	%
Δ V <sub>DD</sub> (HSI)	HSI oscillator frequency drift over V <sub>DD</sub> (reference is 3.3 V)	V <sub>DD</sub> =1.62 to 3.6 V	-0.12	-	0.03	%
Δ T <sub>TEMP</sub> (HSI)	HSI oscillator frequency drift over temperature (reference is 64 MHz)	T <sub>J</sub> =-20 to 105 °C	-1 <sup>(3)</sup>	-	1 <sup>(3)</sup>	%
		T <sub>J</sub> =-40 to T <sub>Jmax</sub> °C	-2 <sup>(3)</sup>	-	1 <sup>(3)</sup>	
t <sub>su</sub> (HSI)	HSI oscillator start-up time	-	-	1.4	2	μs
t <sub>stab</sub> (HSI)	HSI oscillator stabilization time	at 1% of target frequency	-	4	8	μs
I <sub>DD</sub> (HSI)	HSI oscillator power consumption	-	-	300	400	μA

1. Guaranteed by design unless otherwise specified.
2. Guaranteed by test in production.
3. Guaranteed by characterization.

### 4 MHz low-power internal RC oscillator (CSI)

Table 46. CSI oscillator characteristics<sup>(1)</sup>

Symbol	Parameter	Conditions	Min	Typ	Max	Unit
f <sub>CSI</sub>	CSI frequency	V <sub>DD</sub> =3.3 V, T <sub>J</sub> =30 °C	3.96 <sup>(2)</sup>	4	4.04 <sup>(2)</sup>	MHz
TRIM	Trimming step	-	-	0.35	-	%
DuCy(CSI)	Duty Cycle	-	45	-	55	%

**Table 46. CSI oscillator characteristics<sup>(1)</sup> (continued)**

Symbol	Parameter	Conditions	Min	Typ	Max	Unit
$\Delta_{TEMP}$ (CSI)	CSI oscillator frequency drift over temperature	$T_J = 0$ to $85$ °C	-	-3.7 <sup>(3)</sup>	4.5 <sup>(3)</sup>	%
		$T_J = -40$ to $125$ °C	-	-11 <sup>(3)</sup>	7.5 <sup>(3)</sup>	
$D_{VDD}$ (CSI)	CSI oscillator frequency drift over $V_{DD}$	$V_{DD} = 1.62$ to $3.6$ V	-	-0.06	0.06	%
$t_{su}$ (CSI)	CSI oscillator startup time	-	-	1	2	$\mu$ s
$t_{stab}$ (CSI)	CSI oscillator stabilization time (to reach $\pm 3\%$ of $f_{CSI}$ )	-	-	4	8	cycle
$I_{DD}$ (CSI)	CSI oscillator power consumption	-	-	23	30	$\mu$ A

1. Guaranteed by design.
2. Guaranteed by test in production.
3. Guaranteed by characterization.

### Low-speed internal (LSI) RC oscillator

**Table 47. LSI oscillator characteristics**

Symbol	Parameter	Conditions	Min	Typ	Max	Unit
$f_{LSI}$ <sup>(1)</sup>	LSI frequency	$V_{DD} = 3.3$ V, $T_J = 25$ °C	31.4	32	32.6	kHz
		$T_J = -40$ to $105$ °C, $V_{DD} = 1.62$ to $3.6$ V	29.76	-	33.60	
$t_{su}$ (LSI) <sup>(2)</sup>	LSI oscillator startup time	-	-	80	130	$\mu$ s
$t_{stab}$ (LSI) <sup>(2)</sup>	LSI oscillator stabilization time (5% of final value)	-	-	120	170	
$I_{DD}$ (LSI) <sup>(2)</sup>	LSI oscillator power consumption	-	-	130	280	nA

1. Guaranteed by characterization results.
2. Guaranteed by design.

### 6.3.10 PLL characteristics

The parameters given in [Table 48](#) are derived from tests performed under temperature and  $V_{DD}$  supply voltage conditions summarized in [Table 22: General operating conditions](#).

**Table 48. PLL characteristics (wide VCO frequency range)<sup>(1)</sup>**

Symbol	Parameter	Conditions	Min	Typ	Max	Unit
$f_{PLL\_IN}$	PLL input clock	-	2	-	16	MHz
	PLL input clock duty cycle	-	10	-	90	%

**Table 48. PLL characteristics (wide VCO frequency range)<sup>(1)</sup> (continued)**

Symbol	Parameter	Conditions	Min	Typ	Max	Unit	
f <sub>PLL_P_OUT</sub>	PLL multiplier output clock P	VOS1	1.5	-	400 <sup>(2)</sup>	MHz	
		VOS2	1.5	-	300		
		VOS3	1.5	-	200		
f <sub>PLL_Q_OUT</sub>	PLL multiplier output clock Q/R	VOS1	1.5	-	400 <sup>(2)</sup>		
		VOS2	1.5	-	300		
		VOS3	1.5	-	200		
f <sub>VCO_OUT</sub>	PLL VCO output	-	192	-	836		
t <sub>LOCK</sub>	PLL lock time	Normal mode	-	50 <sup>(3)</sup>	150 <sup>(3)</sup>	µs	
		Sigma-delta mode (CKIN ≥ 8 MHz)	-	58 <sup>(3)</sup>	166 <sup>(3)</sup>		
Jitter	Cycle-to-cycle jitter <sup>(4)</sup>	VCO = 192 MHz	-	134	-	± ps	
		VCO = 200 MHz	-	134	-		
		VCO = 400 MHz	-	76	-		
		VCO = 800 MHz	-	39	-		
	Long term jitter	Normal mode	-	±0.7	-	%	
		Sigma-delta mode (CKIN = 16 MHz)	-	±0.8	-		
I <sub>DD(PLL)</sub> <sup>(3)</sup>	PLL power consumption on V <sub>DD</sub>	VCO freq = 420 MHz	V <sub>DDA</sub>	-	440	1150	µA
			V <sub>CORE</sub>	-	530	-	
		VCO freq = 150 MHz	V <sub>DDA</sub>	-	180	500	
			V <sub>CORE</sub>	-	200	-	

1. Guaranteed by design unless otherwise specified.
2. This value must be limited to the maximum frequency due to the product limitation (400 MHz for VOS1, 300 MHz for VOS2, 200 MHz for VOS3).
3. Guaranteed by characterization results.
4. Integer mode only.

**Table 49. PLL characteristics (medium VCO frequency range)<sup>(1)</sup>**

Symbol	Parameter	Conditions	Min	Typ	Max	Unit
f <sub>PLL_IN</sub>	PLL input clock	-	1	-	2	MHz
	PLL input clock duty cycle	-	10	-	90	%
f <sub>PLL_OUT</sub>	PLL multiplier output clock P, Q, R	VOS1	1.17	-	210	MHz
		VOS2	1.17	-	210	
		VOS3	1.17	-	200	
f <sub>VCO_OUT</sub>	PLL VCO output	-	150	-	420	MHz
t <sub>LOCK</sub>	PLL lock time	Normal mode	-	60 <sup>(2)</sup>	100 <sup>(2)</sup>	µs
		Sigma-delta mode	forbidden	-	-	µs

**Table 49. PLL characteristics (medium VCO frequency range)<sup>(1)</sup> (continued)**

Symbol	Parameter	Conditions	Min	Typ	Max	Unit	
Jitter	Cycle-to-cycle jitter <sup>(3)</sup>	-	VCO = 150 MHz	-	145	-	+/- ps
			VCO = 300 MHz	-	91	-	
			VCO = 400 MHz	-	64	-	
			VCO = 420 MHz	-	63	-	
	Period jitter	f <sub>PLL_OUT</sub> = 50 MHz	VCO = 150 MHz	-	55	-	+/- ps
			VCO = 400 MHz	-	30	-	
	Long term jitter	Normal mode	VCO = 150 MHz	-	-	-	%
			VCO = 300 MHz	-	-	-	
			VCO = 400 MHz	-	+/-0.3	-	
I(PLL) <sup>(2)</sup>	PLL power consumption on V <sub>DD</sub>	VCO freq = 420MHz	VDD	-	440	1150	µA
			VCORE	-	530	-	
		VCO freq = 150MHz	VDD	-	180	500	
			VCORE	-	200	-	

1. Guaranteed by design unless otherwise specified.
2. Guaranteed by characterization results.
3. Integer mode only.

### 6.3.11 Memory characteristics

#### Flash memory

The characteristics are given at T<sub>J</sub> = -40 to 125 °C unless otherwise specified.

The devices are shipped to customers with the Flash memory erased.

**Table 50. Flash memory characteristics**

Symbol	Parameter	Conditions	Min	Typ	Max	Unit
I <sub>DD</sub>	Supply current	Write / Erase 8-bit mode	-	6.5	-	mA
		Write / Erase 16-bit mode	-	11.5	-	
		Write / Erase 32-bit mode	-	20	-	
		Write / Erase 64-bit mode	-	35	-	

**Table 51. Flash memory programming**

Symbol	Parameter	Conditions	Min <sup>(1)</sup>	Typ	Max <sup>(1)</sup>	Unit
t <sub>prog</sub>	Word (266 bits) programming time	Program/erase parallelism x 8	-	290	580 <sup>(2)</sup>	μs
		Program/erase parallelism x 16	-	180	360	
		Program/erase parallelism x 32	-	130	260	
		Program/erase parallelism x 64	-	100	200	
t <sub>ERASE128KB</sub>	Sector (128 KB) erase time	Program/erase parallelism x 8	-	2	4	s
		Program/erase parallelism x 16	-	1.8	3.6	
		Program/erase parallelism x 32	-			
t <sub>ME</sub>	Mass erase time	Program/erase parallelism x 8	-	13	26	
		Program/erase parallelism x 16	-	8	16	
		Program/erase parallelism x 32	-	6	12	
		Program/erase parallelism x 64	-	5	10	
V <sub>prog</sub>	Programming voltage	Program parallelism x 8	1.62	-	3.6	V
		Program parallelism x 16				
		Program parallelism x 32				
		Program parallelism x 64	1.8	-	3.6	

1. Guaranteed by characterization results.
2. The maximum programming time is measured after 10K erase operations.

**Table 52. Flash memory endurance and data retention**

Symbol	Parameter	Conditions	Value	Unit
			Min <sup>(1)</sup>	
N <sub>END</sub>	Endurance	T <sub>J</sub> = -40 to +125 °C (6 suffix versions)	10	kcycles
t <sub>RET</sub>	Data retention	1 kcycle at T <sub>A</sub> = 85 °C	30	Years
		10 kcycles at T <sub>A</sub> = 55 °C	20	

1. Guaranteed by characterization results.

### 6.3.12 EMC characteristics

Susceptibility tests are performed on a sample basis during device characterization.

#### Functional EMS (electromagnetic susceptibility)

While a simple application is executed on the device (toggling 2 LEDs through I/O ports), the device is stressed by two electromagnetic events until a failure occurs. The failure is indicated by the LEDs:

- **Electrostatic discharge (ESD)** (positive and negative) is applied to all device pins until a functional disturbance occurs. This test is compliant with the IEC 61000-4-2 standard.
- **FTB**: A burst of fast transient voltage (positive and negative) is applied to  $V_{DD}$  and  $V_{SS}$  through a 100 pF capacitor, until a functional disturbance occurs. This test is compliant with the IEC 61000-4-4 standard.

A device reset allows normal operations to be resumed.

The test results are given in [Table 53](#). They are based on the EMS levels and classes defined in application note AN1709.

**Table 53. EMS characteristics**

Symbol	Parameter	Conditions	Level/Class
$V_{FESD}$	Voltage limits to be applied on any I/O pin to induce a functional disturbance	$V_{DD} = 3.3\text{ V}$ , $T_A = +25\text{ °C}$ , UFBGA240, $f_{rcc\_c\_ck} = 400\text{ MHz}$ , conforms to IEC 61000-4-2	3B
$V_{FTB}$	Fast transient voltage burst limits to be applied through 100 pF on $V_{DD}$ and $V_{SS}$ pins to induce a functional disturbance		4B

As a consequence, it is recommended to add a serial resistor (1 k $\Omega$ ) located as close as possible to the MCU to the pins exposed to noise (connected to tracks longer than 50 mm on PCB).

#### Designing hardened software to avoid noise problems

EMC characterization and optimization are performed at component level with a typical application environment and simplified MCU software. It should be noted that good EMC performance is highly dependent on the user application and the software in particular.

Therefore it is recommended that the user applies EMC software optimization and prequalification tests in relation with the EMC level requested for his application.

#### Software recommendations

The software flowchart must include the management of runaway conditions such as:

- Corrupted program counter
- Unexpected reset
- Critical Data corruption (control registers...)

**Prequalification trials**

Most of the common failures (unexpected reset and program counter corruption) can be reproduced by manually forcing a low state on the NRST pin or the Oscillator pins for 1 second.

To complete these trials, ESD stress can be applied directly on the device, over the range of specification values. When unexpected behavior is detected, the software can be hardened to prevent unrecoverable errors occurring (see application note AN1015).

**Electromagnetic Interference (EMI)**

The electromagnetic field emitted by the device are monitored while a simple application, executing EEMBC code, is running. This emission test is compliant with SAE IEC61967-2 standard which specifies the test board and the pin loading.

**Table 54. EMI characteristics**

Symbol	Parameter	Conditions	Monitored frequency band	Max vs. [f <sub>HSE</sub> /f <sub>CPU</sub> ]	Unit
				8/400 MHz	
S <sub>EMI</sub>	Peak level	V <sub>DD</sub> = 3.6 V, T <sub>A</sub> = 25 °C, UFBGA240 package, conforming to IEC61967-2	0.1 to 30 MHz	6	dBμV
			30 to 130 MHz	5	
			130 MHz to 1 GHz	13	
			1 GHz to 2 GHz	7	
			EMI Level	2.5	-

**6.3.13 Absolute maximum ratings (electrical sensitivity)**

Based on three different tests (ESD, LU) using specific measurement methods, the device is stressed in order to determine its performance in terms of electrical sensitivity.

**Electrostatic discharge (ESD)**

Electrostatic discharges (a positive then a negative pulse) are applied to the pins of each sample according to each pin combination. This test conforms to the ANSI/ESDA/JEDEC JS-001 and ANSI/ESDA/JEDEC JS-002 standards.

**Table 55. ESD absolute maximum ratings**

Symbol	Ratings	Conditions	Packages	Class	Maximum value <sup>(1)</sup>	Unit
V <sub>ESD(HBM)</sub>	Electrostatic discharge voltage (human body model)	T <sub>A</sub> = +25 °C conforming to ANSI/ESDA/JEDEC JS-001	All	1C	1000	V
V <sub>ESD(CDM)</sub>	Electrostatic discharge voltage (charge device model)	T <sub>A</sub> = +25 °C conforming to ANSI/ESDA/JEDEC JS-002	All	C1	250	

1. Guaranteed by characterization results.

**Static latchup**

Two complementary static tests are required on six parts to assess the latchup performance:

- A supply overvoltage is applied to each power supply pin
- A current injection is applied to each input, output and configurable I/O pin

These tests are compliant with JESD78 IC latchup standard.

**Table 56. Electrical sensitivities**

Symbol	Parameter	Conditions	Class
LU	Static latchup class	T <sub>A</sub> = +25 °C conforming to JESD78	II level A

**6.3.14 I/O current injection characteristics**

As a general rule, a current injection to the I/O pins, due to external voltage below V<sub>SS</sub> or above V<sub>DD</sub> (for standard, 3.3 V-capable I/O pins) should be avoided during the normal product operation. However, in order to give an indication of the robustness of the microcontroller in cases when an abnormal injection accidentally happens, susceptibility tests are performed on a sample basis during the device characterization.

**Functional susceptibility to I/O current injection**

While a simple application is executed on the device, the device is stressed by injecting current into the I/O pins programmed in floating input mode. While current is injected into the I/O pin, one at a time, the device is checked for functional failures.

The failure is indicated by an out of range parameter: ADC error above a certain limit (higher than 5 LSB TUE), out of conventional limits of induced leakage current on adjacent pins (out of -5 µA/+0 µA range), or other functional failure (for example reset, oscillator frequency deviation).

The following tables are the compilation of the SIC1/SIC2 and functional ESD results.

Negative induced A negative induced leakage current is caused by negative injection and positive induced leakage current by positive injection.

**Table 57. I/O current injection susceptibility<sup>(1)</sup>**

Symbol	Description	Functional susceptibility		Unit
		Negative injection	Positive injection	
I <sub>INJ</sub>	PA7, PC5, PG1, PB14, PJ7, PA11, PA12, PA13, PA14, PA15, PJ12, PB4	5	0	mA
	PA2, PH2, PH3, PE8, PA6, PA7, PC4, PE7, PE10, PE11	0	NA	
	PA0, PA_C, PA1, PA1_C, PC2, PC2_C, PC3, PC3_C, PA4, PA5, PH4, PH5, BOOT0	0	0	
	All other I/Os	5	NA	

1. Guaranteed by characterization.



### 6.3.15 I/O port characteristics

#### General input/output characteristics

Unless otherwise specified, the parameters given in [Table 58: I/O static characteristics](#) are derived from tests performed under the conditions summarized in [Table 22: General operating conditions](#). All I/Os are CMOS and TTL compliant (except for BOOT0).

**Table 58. I/O static characteristics**

Symbol	Parameter	Condition	Min	Typ	Max	Unit
$V_{IL}$	I/O input low level voltage except BOOT0	$1.62\text{ V} < V_{DDIOx} < 3.6\text{ V}$	-	-	$0.3V_{DD}^{(1)}$	V
	I/O input low level voltage except BOOT0		-	-	$0.4V_{DD} - 0.1^{(2)}$	
	BOOT0 I/O input low level voltage		-	-	$0.19V_{DD} + 0.1^{(2)}$	
$V_{IH}$	I/O input high level voltage except BOOT0	$1.62\text{ V} < V_{DDIOx} < 3.6\text{ V}$	$0.7V_{DD}^{(1)}$	-	-	V
	I/O input high level voltage except BOOT0 <sup>(3)</sup>		$0.47V_{DD} + 0.25^{(2)}$	-	-	
	BOOT0 I/O input high level voltage <sup>(3)</sup>		$0.17V_{DD} + 0.6^{(2)}$	-	-	
$V_{HYS}^{(2)}$	TT_xx, FT_XXX and NRST I/O input hysteresis	$1.62\text{ V} < V_{DDIOx} < 3.6\text{ V}$	-	250	-	mV
	BOOT0 I/O input hysteresis		-	200	-	
$I_{leak}^{(4)}$	FT_xx Input leakage current <sup>(2)</sup>	$0 < V_{IN} \leq \text{Max}(V_{DDXXX})^{(9)}$	-	-	+/-250	nA
		$\text{Max}(V_{DDXXX}) < V_{IN} \leq 5.5\text{ V}$ <sup>(5)(6)(9)</sup>	-	-	1500	
	FT_u IO	$0 < V_{IN} \leq \text{Max}(V_{DDXXX})^{(9)}$	-	-	+/- 350	
		$\text{Max}(V_{DDXXX}) < V_{IN} \leq 5.5\text{ V}$ <sup>(5)(6)(9)</sup>	-	-	5000 <sup>(7)</sup>	
	TT_xx Input leakage current	$0 < V_{IN} \leq \text{Max}(V_{DDXXX})^{(9)}$	-	-	+/-250	
	VPP (BOOT0 alternate function)	$0 < V_{IN} \leq V_{DDIOx}$	-	-	15	
$V_{DDIOx} < V_{IN} \leq 9\text{ V}$		-	-	35		
$R_{PU}$	Weak pull-up equivalent resistor <sup>(8)</sup>	$V_{IN} = V_{SS}$	30	40	50	kΩ
$R_{PD}$	Weak pull-down equivalent resistor <sup>(8)</sup>	$V_{IN} = V_{DD}^{(9)}$	30	40	50	
$C_{IO}$	I/O pin capacitance	-	-	5	-	pF

1. Compliant with CMOS requirement.

2. Guaranteed by design.

3.  $V_{DDIOx}$  represents  $V_{DDIO1}$ ,  $V_{DDIO2}$  or  $V_{DDIO3}$ .  $V_{DDIOx} = V_{DD}$ .

4. This parameter represents the pad leakage of the I/O itself. The total product pad leakage is provided by the following formula:  $I_{Total\_leak\_max} = 10\ \mu\text{A} + [\text{number of I/Os where } V_{IN} \text{ is applied on the pad}] \times I_{Ikg}(\text{Max})$ .

5. All FT\_xx IO except FT\_lu, FT\_u and PC3.

6.  $V_{IN}$  must be less than  $\text{Max}(V_{DDXXX}) + 3.6 \text{ V}$ .
7. To sustain a voltage higher than  $\text{MIN}(V_{DD}, V_{DDA}, V_{DD33USB}) + 0.3 \text{ V}$ , the internal pull-up and pull-down resistors must be disabled.
8. The pull-up and pull-down resistors are designed with a true resistance in series with a switchable PMOS/NMOS. This PMOS/NMOS contribution to the series resistance is minimal (~10% order).
9.  $\text{Max}(V_{DDXXX})$  is the maximum value of all the I/O supplies.

All I/Os are CMOS and TTL compliant (no software configuration required). Their characteristics cover more than the strict CMOS-technology or TTL parameters. The coverage of these requirements for FT I/Os is shown in [Figure 18](#).

**Figure 18.  $V_{IL}/V_{IH}$  for all I/Os except BOOT0**

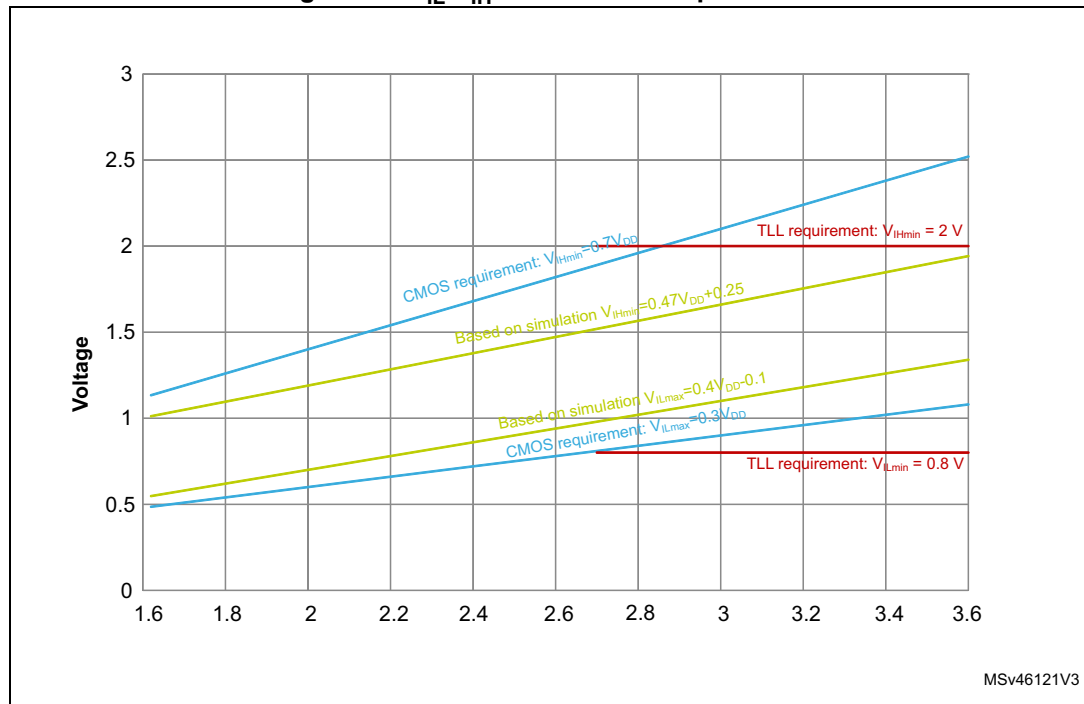

### Output driving current

The GPIOs (general purpose input/outputs) can sink or source up to  $\pm 8 \text{ mA}$ , and sink or source up to  $\pm 20 \text{ mA}$  (with a relaxed  $V_{OL}/V_{OH}$ ).

In the user application, the number of I/O pins which can drive current must be limited to respect the absolute maximum rating specified in [Section 6.2](#). In particular:

- The sum of the currents sourced by all the I/Os on  $V_{DD}$ , plus the maximum Run consumption of the MCU sourced on  $V_{DD}$ , cannot exceed the absolute maximum rating  $\Sigma I_{VDD}$  (see [Table 20](#)).
- The sum of the currents sunk by all the I/Os on  $V_{SS}$  plus the maximum Run consumption of the MCU sunk on  $V_{SS}$  cannot exceed the absolute maximum rating  $\Sigma I_{VSS}$  (see [Table 20](#)).

### Output voltage levels

Unless otherwise specified, the parameters given in [Table 59](#) are derived from tests performed under ambient temperature and  $V_{DD}$  supply voltage conditions summarized in [Table 22: General operating conditions](#). All I/Os are CMOS and TTL compliant.

**Table 59. Output voltage characteristics for all I/Os except PC13, PC14, PC15 and PI8<sup>(1)</sup>**

Symbol	Parameter	Conditions <sup>(3)</sup>	Min	Max	Unit
$V_{OL}$	Output low level voltage	CMOS port <sup>(2)</sup> $I_{IO}=8\text{ mA}$ $2.7\text{ V} \leq V_{DD} \leq 3.6\text{ V}$	-	0.4	V
$V_{OH}$	Output high level voltage	CMOS port <sup>(2)</sup> $I_{IO}=-8\text{ mA}$ $2.7\text{ V} \leq V_{DD} \leq 3.6\text{ V}$	$V_{DD}-0.4$	-	
$V_{OL}^{(3)}$	Output low level voltage	TTL port <sup>(2)</sup> $I_{IO}=8\text{ mA}$ $2.7\text{ V} \leq V_{DD} \leq 3.6\text{ V}$	-	0.4	
$V_{OH}^{(3)}$	Output high level voltage	TTL port <sup>(2)</sup> $I_{IO}=-8\text{ mA}$ $2.7\text{ V} \leq V_{DD} \leq 3.6\text{ V}$	2.4	-	
$V_{OL}^{(3)}$	Output low level voltage	$I_{IO}=20\text{ mA}$ $2.7\text{ V} \leq V_{DD} \leq 3.6\text{ V}$	-	1.3	
$V_{OH}^{(3)}$	Output high level voltage	$I_{IO}=-20\text{ mA}$ $2.7\text{ V} \leq V_{DD} \leq 3.6\text{ V}$	$V_{DD}-1.3$	-	
$V_{OL}^{(3)}$	Output low level voltage	$I_{IO}=4\text{ mA}$ $1.62\text{ V} \leq V_{DD} \leq 3.6\text{ V}$	-	0.4	
$V_{OH}^{(3)}$	Output high level voltage	$I_{IO}=-4\text{ mA}$ $1.62\text{ V} \leq V_{DD} < 3.6\text{ V}$	$V_{DD}-0.4$	-	
$V_{OLFM+}^{(3)}$	Output low level voltage for an FTf I/O pin in FM+ mode	$I_{IO}=20\text{ mA}$ $2.3\text{ V} \leq V_{DD} \leq 3.6\text{ V}$	-	0.4	
		$I_{IO}=10\text{ mA}$ $1.62\text{ V} \leq V_{DD} \leq 3.6\text{ V}$	-	0.4	

- The I/O current sourced or sunk by the device must always respect the absolute maximum rating specified in [Table 19: Voltage characteristics](#), and the sum of the currents sourced or sunk by all the I/Os (I/O ports and control pins) must always respect the absolute maximum ratings  $\Sigma I_{IO}$ .
- TTL and CMOS outputs are compatible with JEDEC standards JESD36 and JESD52.
- Guaranteed by design.

Table 60. Output voltage characteristics for PC13, PC14, PC15 and PI8<sup>(1)</sup>

Symbol	Parameter	Conditions <sup>(3)</sup>	Min	Max	Unit
$V_{OL}$	Output low level voltage	CMOS port <sup>(2)</sup> $I_{IO}=3\text{ mA}$ $2.7\text{ V} \leq V_{DD} \leq 3.6\text{ V}$	-	0.4	V
$V_{OH}$	Output high level voltage	CMOS port <sup>(2)</sup> $I_{IO}=-3\text{ mA}$ $2.7\text{ V} \leq V_{DD} \leq 3.6\text{ V}$	$V_{DD}-0.4$	-	
$V_{OL}^{(3)}$	Output low level voltage	TTL port <sup>(2)</sup> $I_{IO}=3\text{ mA}$ $2.7\text{ V} \leq V_{DD} \leq 3.6\text{ V}$	-	0.4	
$V_{OH}^{(3)}$	Output high level voltage	TTL port <sup>(2)</sup> $I_{IO}=-3\text{ mA}$ $2.7\text{ V} \leq V_{DD} \leq 3.6\text{ V}$	2.4	-	
$V_{OL}^{(3)}$	Output low level voltage	$I_{IO}=1.5\text{ mA}$ $1.62\text{ V} \leq V_{DD} \leq 3.6\text{ V}$	-	0.4	
$V_{OH}^{(3)}$	Output high level voltage	$I_{IO}=-1.5\text{ mA}$ $1.62\text{ V} \leq V_{DD} \leq 3.6\text{ V}$	$V_{DD}-0.4$	-	

1. The I/O current sourced or sunk by the device must always respect the absolute maximum rating specified in [Table 19: Voltage characteristics](#), and the sum of the currents sourced or sunk by all the I/Os (I/O ports and control pins) must always respect the absolute maximum ratings  $\Sigma I_{IO}$ .
2. TTL and CMOS outputs are compatible with JEDEC standards JESD36 and JESD52.
3. Guaranteed by design.

**Output buffer timing characteristics (HSLV option disabled)**

The HSLV bit of SYSCFG\_CCCSR register can be used to optimize the I/O speed when the product voltage is below 2.5 V.

**Table 61. Output timing characteristics (HSLV OFF)<sup>(1)(2)</sup>**

Speed	Symbol	Parameter	conditions	Min	Max	Unit
00	F <sub>max</sub> <sup>(3)</sup>	Maximum frequency	C=50 pF, 2.7 V ≤ V <sub>DD</sub> ≤ 3.6 V	-	12	MHz
			C=50 pF, 1.62 V ≤ V <sub>DD</sub> ≤ 2.7 V	-	3	
			C=30 pF, 2.7 V ≤ V <sub>DD</sub> ≤ 3.6 V	-	12	
			C=30 pF, 1.62 V ≤ V <sub>DD</sub> ≤ 2.7 V	-	3	
			C=10 pF, 2.7 V ≤ V <sub>DD</sub> ≤ 3.6 V	-	16	
			C=10 pF, 1.62 V ≤ V <sub>DD</sub> ≤ 2.7 V	-	4	
	t <sub>r</sub> /t <sub>f</sub> <sup>(4)</sup>	Output high to low level fall time and output low to high level rise time	C=50 pF, 2.7 V ≤ V <sub>DD</sub> ≤ 3.6 V	-	16.6	ns
			C=50 pF, 1.62 V ≤ V <sub>DD</sub> ≤ 2.7 V	-	33.3	
			C=30 pF, 2.7 V ≤ V <sub>DD</sub> ≤ 3.6 V	-	13.3	
			C=30 pF, 1.62 V ≤ V <sub>DD</sub> ≤ 2.7 V	-	25	
			C=10 pF, 2.7 V ≤ V <sub>DD</sub> ≤ 3.6 V	-	10	
			C=10 pF, 1.62 V ≤ V <sub>DD</sub> ≤ 2.7 V	-	20	
01	F <sub>max</sub> <sup>(3)</sup>	Maximum frequency	C=50 pF, 2.7 V ≤ V <sub>DD</sub> ≤ 3.6 V	-	60	MHz
			C=50 pF, 1.62 V ≤ V <sub>DD</sub> ≤ 2.7 V	-	15	
			C=30 pF, 2.7 V ≤ V <sub>DD</sub> ≤ 3.6 V	-	80	
			C=30 pF, 1.62 V ≤ V <sub>DD</sub> ≤ 2.7 V	-	15	
			C=10 pF, 2.7 V ≤ V <sub>DD</sub> ≤ 3.6 V	-	110	
			C=10 pF, 1.62 V ≤ V <sub>DD</sub> ≤ 2.7 V	-	20	
	t <sub>r</sub> /t <sub>f</sub> <sup>(4)</sup>	Output high to low level fall time and output low to high level rise time	C=50 pF, 2.7 V ≤ V <sub>DD</sub> ≤ 3.6 V	-	5.2	ns
			C=50 pF, 1.62 V ≤ V <sub>DD</sub> ≤ 2.7 V	-	10	
			C=30 pF, 2.7 V ≤ V <sub>DD</sub> ≤ 3.6 V	-	4.2	
			C=30 pF, 1.62 V ≤ V <sub>DD</sub> ≤ 2.7 V	-	7.5	
			C=10 pF, 2.7 V ≤ V <sub>DD</sub> ≤ 3.6 V	-	2.8	
			C=10 pF, 1.62 V ≤ V <sub>DD</sub> ≤ 2.7 V	-	5.2	

Table 61. Output timing characteristics (HSLV OFF)<sup>(1)(2)</sup> (continued)

Speed	Symbol	Parameter	conditions	Min	Max	Unit
10	$F_{\max}^{(3)}$	Maximum frequency	C=50 pF, 2.7 V ≤ V <sub>DD</sub> ≤ 3.6 V <sup>(5)</sup>	-	85	MHz
			C=50 pF, 1.62 V ≤ V <sub>DD</sub> ≤ 2.7 V <sup>(5)</sup>	-	35	
			C=30 pF, 2.7 V ≤ V <sub>DD</sub> ≤ 3.6 V <sup>(5)</sup>	-	110	
			C=30 pF, 1.62 V ≤ V <sub>DD</sub> ≤ 2.7 V <sup>(5)</sup>	-	40	
			C=10 pF, 2.7 V ≤ V <sub>DD</sub> ≤ 3.6 V <sup>(5)</sup>	-	166	
			C=10 pF, 1.62 V ≤ V <sub>DD</sub> ≤ 2.7 V <sup>(5)</sup>	-	100	
	$t_r/t_f^{(4)}$	Output high to low level fall time and output low to high level rise time	C=50 pF, 2.7 V ≤ V <sub>DD</sub> ≤ 3.6 V <sup>(5)</sup>	-	3.8	ns
			C=50 pF, 1.62 V ≤ V <sub>DD</sub> ≤ 2.7 V <sup>(5)</sup>	-	6.9	
			C=30 pF, 2.7 V ≤ V <sub>DD</sub> ≤ 3.6 V <sup>(5)</sup>	-	2.8	
			C=30 pF, 1.62 V ≤ V <sub>DD</sub> ≤ 2.7 V <sup>(5)</sup>	-	5.2	
11	$F_{\max}^{(3)}$	Maximum frequency	C=50 pF, 2.7 V ≤ V <sub>DD</sub> ≤ 3.6 V <sup>(5)</sup>	-	100	MHz
			C=50 pF, 1.62 V ≤ V <sub>DD</sub> ≤ 2.7 V <sup>(5)</sup>	-	50	
			C=30 pF, 2.7 V ≤ V <sub>DD</sub> ≤ 3.6 V <sup>(5)</sup>	-	133	
			C=30 pF, 1.62 V ≤ V <sub>DD</sub> ≤ 2.7 V <sup>(5)</sup>	-	66	
			C=10 pF, 2.7 V ≤ V <sub>DD</sub> ≤ 3.6 V <sup>(5)</sup>	-	220	
			C=10 pF, 1.62 V ≤ V <sub>DD</sub> ≤ 2.7 V <sup>(5)</sup>	-	85	
	$t_r/t_f^{(4)}$	Output high to low level fall time and output low to high level rise time	C=50 pF, 2.7 V ≤ V <sub>DD</sub> ≤ 3.6 V <sup>(5)</sup>	-	3.3	ns
			C=50 pF, 1.62 V ≤ V <sub>DD</sub> ≤ 2.7 V <sup>(5)</sup>	-	6.6	
			C=30 pF, 2.7 V ≤ V <sub>DD</sub> ≤ 3.6 V <sup>(5)</sup>	-	2.4	
			C=30 pF, 1.62 V ≤ V <sub>DD</sub> ≤ 2.7 V <sup>(5)</sup>	-	4.5	
			C=10 pF, 2.7 V ≤ V <sub>DD</sub> ≤ 3.6 V <sup>(5)</sup>	-	1.5	
			C=10 pF, 1.62 V ≤ V <sub>DD</sub> ≤ 2.7 V <sup>(5)</sup>	-	2.7	

1. Guaranteed by design.

2. The frequency of the GPIOs that can be supplied in V<sub>BAT</sub> mode (PC13, PC14, PC15 and PI8) is limited to 2 MHz

3. The maximum frequency is defined with the following conditions:

$$(t_r + t_f) \leq 2/3 T$$

$$\text{Skew} \leq 1/20 T$$

$$45\% < \text{Duty cycle} < 55\%$$

4. The fall and rise times are defined between 90% and 10% and between 10% and 90% of the output waveform, respectively.

5. Compensation system enabled.

Output buffer timing characteristics (HSLV option enabled)

Table 62. Output timing characteristics (HSLV ON)<sup>(1)</sup>

Speed	Symbol	Parameter	conditions	Min	Max	Unit
00	F <sub>max</sub> <sup>(2)</sup>	Maximum frequency	C=50 pF, 1.62 V ≤ V <sub>DD</sub> ≤ 2.7 V	-	10	MHz
			C=30 pF, 1.62 V ≤ V <sub>DD</sub> ≤ 2.7 V	-	10	
			C=10 pF, 1.62 V ≤ V <sub>DD</sub> ≤ 2.7 V	-	10	
	t <sub>r</sub> /t <sub>f</sub> <sup>(3)</sup>	Output high to low level fall time and output low to high level rise time	C=50 pF, 1.62 V ≤ V <sub>DD</sub> ≤ 2.7 V	-	11	ns
			C=30 pF, 1.62 V ≤ V <sub>DD</sub> ≤ 2.7 V	-	9	
			C=10 pF, 1.62 V ≤ V <sub>DD</sub> ≤ 2.7 V	-	6.6	
01	F <sub>max</sub> <sup>(3)</sup>	Maximum frequency	C=50 pF, 1.62 V ≤ V <sub>DD</sub> ≤ 2.7 V	-	50	MHz
			C=30 pF, 1.62 V ≤ V <sub>DD</sub> ≤ 2.7 V	-	58	
			C=10 pF, 1.62 V ≤ V <sub>DD</sub> ≤ 2.7 V	-	66	
	t <sub>r</sub> /t <sub>f</sub> <sup>(4)</sup>	Output high to low level fall time and output low to high level rise time	C=50 pF, 1.62 V ≤ V <sub>DD</sub> ≤ 2.7 V	-	6.6	ns
			C=30 pF, 1.62 V ≤ V <sub>DD</sub> ≤ 2.7 V	-	4.8	
			C=10 pF, 1.62 V ≤ V <sub>DD</sub> ≤ 2.7 V	-	3	
10	F <sub>max</sub> <sup>(3)</sup>	Maximum frequency	C=50 pF, 1.62 V ≤ V <sub>DD</sub> ≤ 2.7 V <sup>(4)</sup>	-	55	MHz
			C=30 pF, 1.62 V ≤ V <sub>DD</sub> ≤ 2.7 V <sup>(5)</sup>	-	80	
			C=10 pF, 1.62 V ≤ V <sub>DD</sub> ≤ 2.7 V <sup>(5)</sup>	-	133	
	t <sub>r</sub> /t <sub>f</sub> <sup>(4)</sup>	Output high to low level fall time and output low to high level rise time	C=50 pF, 1.62 V ≤ V <sub>DD</sub> ≤ 2.7 V <sup>(5)</sup>	-	5.8	ns
			C=30 pF, 1.62 V ≤ V <sub>DD</sub> ≤ 2.7 V <sup>(5)</sup>	-	4	
			C=10 pF, 1.62 V ≤ V <sub>DD</sub> ≤ 2.7 V <sup>(5)</sup>	-	2.4	
11	F <sub>max</sub> <sup>(3)</sup>	Maximum frequency	C=50 pF, 1.62 V ≤ V <sub>DD</sub> ≤ 2.7 V <sup>(5)</sup>	-	60	MHz
			C=30 pF, 1.62 V ≤ V <sub>DD</sub> ≤ 2.7 V <sup>(5)</sup>	-	90	
			C=10 pF, 1.62 V ≤ V <sub>DD</sub> ≤ 2.7 V <sup>(5)</sup>	-	175	
	t <sub>r</sub> /t <sub>f</sub> <sup>(4)</sup>	Output high to low level fall time and output low to high level rise time	C=50 pF, 1.62 V ≤ V <sub>DD</sub> ≤ 2.7 V <sup>(5)</sup>	-	5.3	ns
			C=30 pF, 1.62 V ≤ V <sub>DD</sub> ≤ 2.7 V <sup>(5)</sup>	-	3.6	
			C=10 pF, 1.62 V ≤ V <sub>DD</sub> ≤ 2.7 V <sup>(5)</sup>	-	1.9	

1. Guaranteed by design.
2. The maximum frequency is defined with the following conditions:  
 (t<sub>r</sub>+t<sub>f</sub>) ≤ 2/3 T  
 Skew ≤ 1/20 T  
 45% < Duty cycle < 55%
3. The fall and rise times are defined between 90% and 10% and between 10% and 90% of the output waveform, respectively.
4. Compensation system enabled.

### 6.3.16 NRST pin characteristics

The NRST pin input driver uses CMOS technology. It is connected to a permanent pull-up resistor,  $R_{PU}$  (see [Table 58: I/O static characteristics](#)).

Unless otherwise specified, the parameters given in [Table 63](#) are derived from tests performed under the ambient temperature and  $V_{DD}$  supply voltage conditions summarized in [Table 22: General operating conditions](#).

**Table 63. NRST pin characteristics**

Symbol	Parameter	Conditions	Min	Typ	Max	Unit
$R_{PU}^{(2)}$	Weak pull-up equivalent resistor <sup>(1)</sup>	$V_{IN} = V_{SS}$	30	40	50	?
$V_{F(NRST)}^{(2)}$	NRST Input filtered pulse	$1.71\text{ V} < V_{DD} < 3.6\text{ V}$	-	-	50	ns
$V_{NF(NRST)}^{(2)}$	NRST Input not filtered pulse	$1.71\text{ V} < V_{DD} < 3.6\text{ V}$	300	-	-	
		$1.62\text{ V} < V_{DD} < 3.6\text{ V}$	1000	-	-	

1. The pull-up is designed with a true resistance in series with a switchable PMOS. This PMOS contribution to the series resistance must be minimum (~10% order).
2. Guaranteed by design.

**Figure 19. Recommended NRST pin protection**

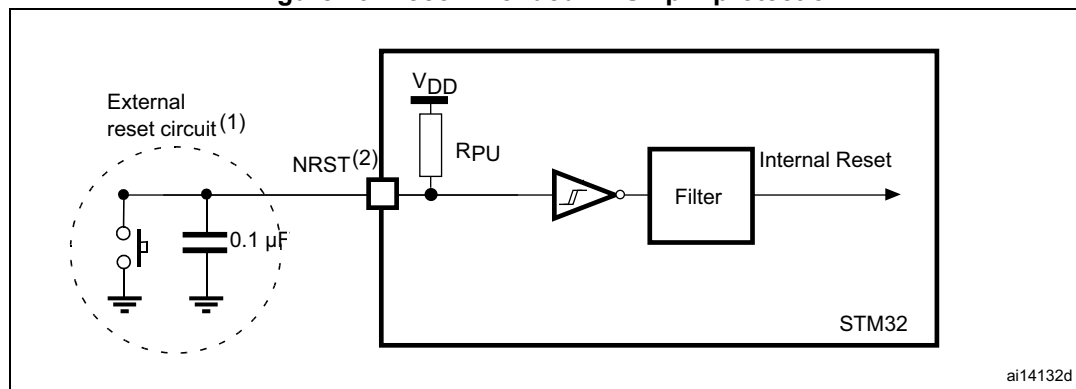

1. The reset network protects the device against parasitic resets.
2. The user must ensure that the level on the NRST pin can go below the  $V_{IL(NRST)}$  max level specified in [Table 58](#). Otherwise the reset is not taken into account by the device.



### 6.3.17 FMC characteristics

Unless otherwise specified, the parameters given in [Table 64](#) to [Table 77](#) for the FMC interface are derived from tests performed under the ambient temperature,  $f_{\text{rcc\_c\_ck}}$  frequency and  $V_{\text{DD}}$  supply voltage conditions summarized in [Table 22: General operating conditions](#), with the following configuration:

- Output speed is set to  $\text{OSPEEDRy}[1:0] = 11$
- Measurement points are done at CMOS levels:  $0.5V_{\text{DD}}$

Refer to [Section 6.3.15: I/O port characteristics](#) for more details on the input/output characteristics.

#### Asynchronous waveforms and timings

[Figure 20](#) through [Figure 23](#) represent asynchronous waveforms and [Table 64](#) through [Table 71](#) provide the corresponding timings. The results shown in these tables are obtained with the following FMC configuration:

- $\text{AddressSetupTime} = 0x1$
- $\text{AddressHoldTime} = 0x1$
- $\text{DataSetupTime} = 0x1$  (except for asynchronous NWAIT mode,  $\text{DataSetupTime} = 0x5$ )
- $\text{BusTurnAroundDuration} = 0x0$
- Capacitive load  $C_L = 30 \text{ pF}$

In all timing tables, the  $T_{\text{KERCK}}$  is the  $f_{\text{mc\_ker\_ck}}$  clock period.

Figure 20. Asynchronous non-multiplexed SRAM/PSRAM/NOR read waveforms

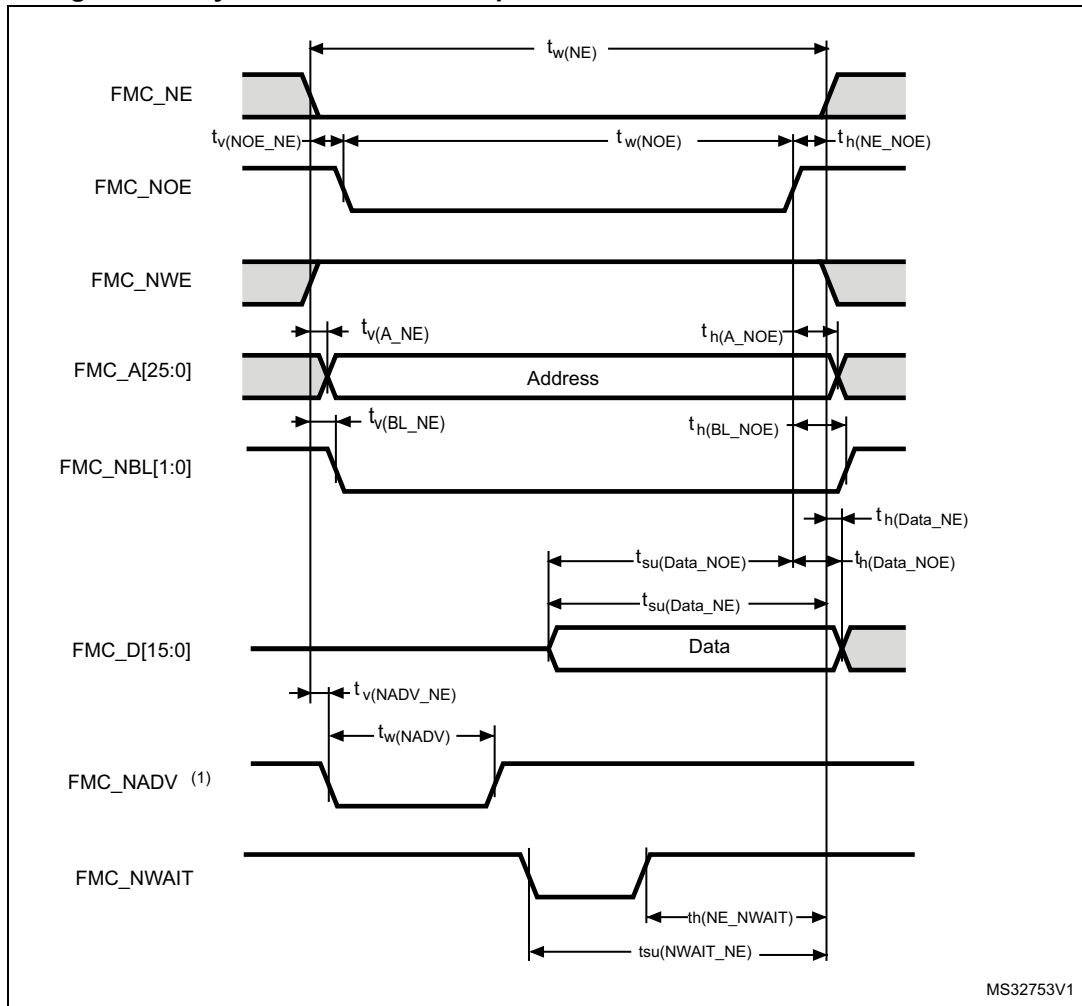

MS32753V1

1. Mode 2/B, C and D only. In Mode 1, FMC\_NADV is not used.

**Table 64. Asynchronous non-multiplexed SRAM/PSRAM/NOR read timings<sup>(1)</sup>**

Symbol	Parameter	Min	Max	Unit
$t_{w(NE)}$	FMC_NE low time	$2T_{fmc\_ker\_ck} - 1$	$2 T_{fmc\_ker\_ck} + 1$	ns
$t_{v(NOE\_NE)}$	FMC_NEx low to FMC_NOE low	0	0.5	
$t_{w(NOE)}$	FMC_NOE low time	$2T_{fmc\_ker\_ck} - 1$	$2T_{fmc\_ker\_ck} + 1$	
$t_{h(NE\_NOE)}$	FMC_NOE high to FMC_NE high hold time	0	-	
$t_{v(A\_NE)}$	FMC_NEx low to FMC_A valid	-	0.5	
$t_{h(A\_NOE)}$	Address hold time after FMC_NOE high	0	-	
$t_{v(BL\_NE)}$	FMC_NEx low to FMC_BL valid	-	0.5	
$t_{h(BL\_NOE)}$	FMC_BL hold time after FMC_NOE high	0	-	
$t_{su(Data\_NE)}$	Data to FMC_NEx high setup time	11	-	
$t_{su(Data\_NOE)}$	Data to FMC_NOEx high setup time	11	-	
$t_{h(Data\_NOE)}$	Data hold time after FMC_NOE high	0	-	
$t_{h(Data\_NE)}$	Data hold time after FMC_NEx high	0	-	
$t_{v(NADV\_NE)}$	FMC_NEx low to FMC_NADV low	-	0	
$t_{w(NADV)}$	FMC_NADV low time	-	$T_{fmc\_ker\_ck} + 1$	

1. Guaranteed by characterization results.

**Table 65. Asynchronous non-multiplexed SRAM/PSRAM/NOR read - NWAIT timings<sup>(1)(2)</sup>**

Symbol	Parameter	Min	Max	Unit
$t_{w(NE)}$	FMC_NE low time	$7T_{fmc\_ker\_ck} + 1$	$7T_{fmc\_ker\_ck} + 1$	ns
$t_{w(NOE)}$	FMC_NWE low time	$5T_{fmc\_ker\_ck} - 1$	$5T_{fmc\_ker\_ck} + 1$	
$t_{w(NWAIT)}$	FMC_NWAIT low time	$T_{fmc\_ker\_ck} - 0.5$	-	
$t_{su(NWAIT\_NE)}$	FMC_NWAIT valid before FMC_NEx high	$4T_{fmc\_ker\_ck} + 11$	-	
$t_{h(NE\_NWAIT)}$	FMC_NEx hold time after FMC_NWAIT invalid	$3T_{fmc\_ker\_ck} + 11.5$	-	

1. Guaranteed by characterization results.

2.  $N_{WAIT}$  pulse width is equal to 1 AHB cycle.

Figure 21. Asynchronous non-multiplexed SRAM/PSRAM/NOR write waveforms

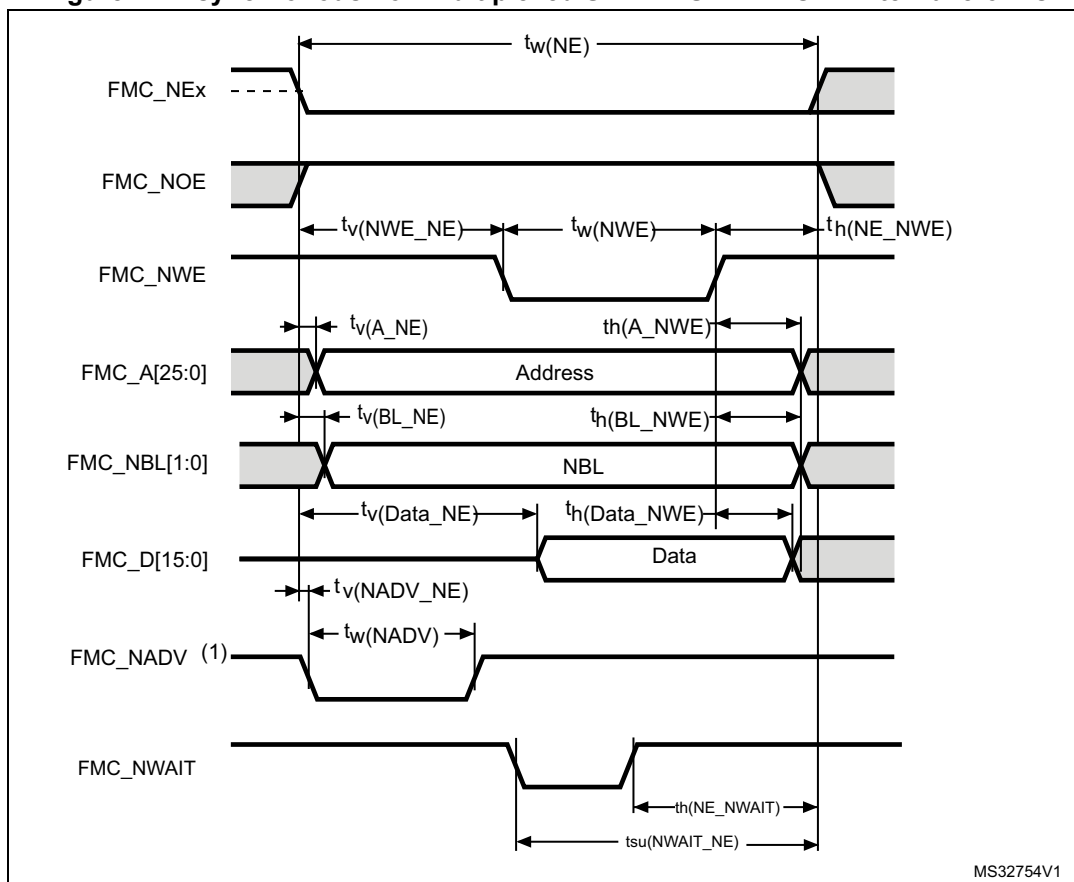

MS32754V1

1. Mode 2/B, C and D only. In Mode 1, FMC\_NADV is not used.

Table 66. Asynchronous non-multiplexed SRAM/PSRAM/NOR write timings<sup>(1)</sup>

Symbol	Parameter	Min	Max	Unit
$t_{w(NE)}$	FMC_NE low time	$3T_{fmc\_ker\_ck} ? 1$	$3T_{fmc\_ker\_ck}$	ns
$t_{v(NWE\_NE)}$	FMC_NEx low to FMC_NWE low	$T_{fmc\_ker\_ck}$	$T_{fmc\_ker\_ck} + 1$	
$t_{w(NWE)}$	FMC_NWE low time	$T_{fmc\_ker\_ck} ? 0.5$	$T_{fmc\_ker\_ck} + 0.5$	
$t_{h(NE\_NWE)}$	FMC_NWE high to FMC_NE high hold time	$T_{fmc\_ker\_ck}$	-	
$t_{v(A\_NE)}$	FMC_NEx low to FMC_A valid	-	2	
$t_{h(A\_NWE)}$	Address hold time after FMC_NWE high	$T_{fmc\_ker\_ck} ? 0.5$	-	
$t_{v(BL\_NE)}$	FMC_NEx low to FMC_BL valid	-	0.5	
$t_{h(BL\_NWE)}$	FMC_BL hold time after FMC_NWE high	$T_{fmc\_ker\_ck} ? 0.5$	-	
$t_{v(Data\_NE)}$	Data to FMC_NEx low to Data valid	-	$T_{fmc\_ker\_ck} + 2.5$	
$t_{h(Data\_NWE)}$	Data hold time after FMC_NWE high	$T_{fmc\_ker\_ck} + 0.5$	-	
$t_{v(NADV\_NE)}$	FMC_NEx low to FMC_NADV low	-	0	
$t_{w(NADV)}$	FMC_NADV low time	-	$T_{fmc\_ker\_ck} + 1$	

1. Guaranteed by characterization results.

**Table 67. Asynchronous non-multiplexed SRAM/PSRAM/NOR write - NWAIT timings<sup>(1)(2)</sup>**

Symbol	Parameter	Min	Max	Unit
$t_{w(NE)}$	FMC_NE low time	$8T_{fmc\_ker\_ck} ? 1$	$8T_{fmc\_ker\_ck} + 1$	ns
$t_{w(NWE)}$	FMC_NWE low time	$6T_{fmc\_ker\_ck} ? 1.5$	$6T_{fmc\_ker\_ck} + 0.5$	
$t_{su(NWAIT\_NE)}$	FMC_NWAIT valid before FMC_NEx high	$5T_{fmc\_ker\_ck} + 13$	-	
$t_{h(NE\_NWAIT)}$	FMC_NEx hold time after FMC_NWAIT invalid	$4T_{fmc\_ker\_ck} + 13$	-	

1. Guaranteed by characterization results.
2.  $N_{WAIT}$  pulse width is equal to 1 AHB cycle.

**Figure 22. Asynchronous multiplexed PSRAM/NOR read waveforms**

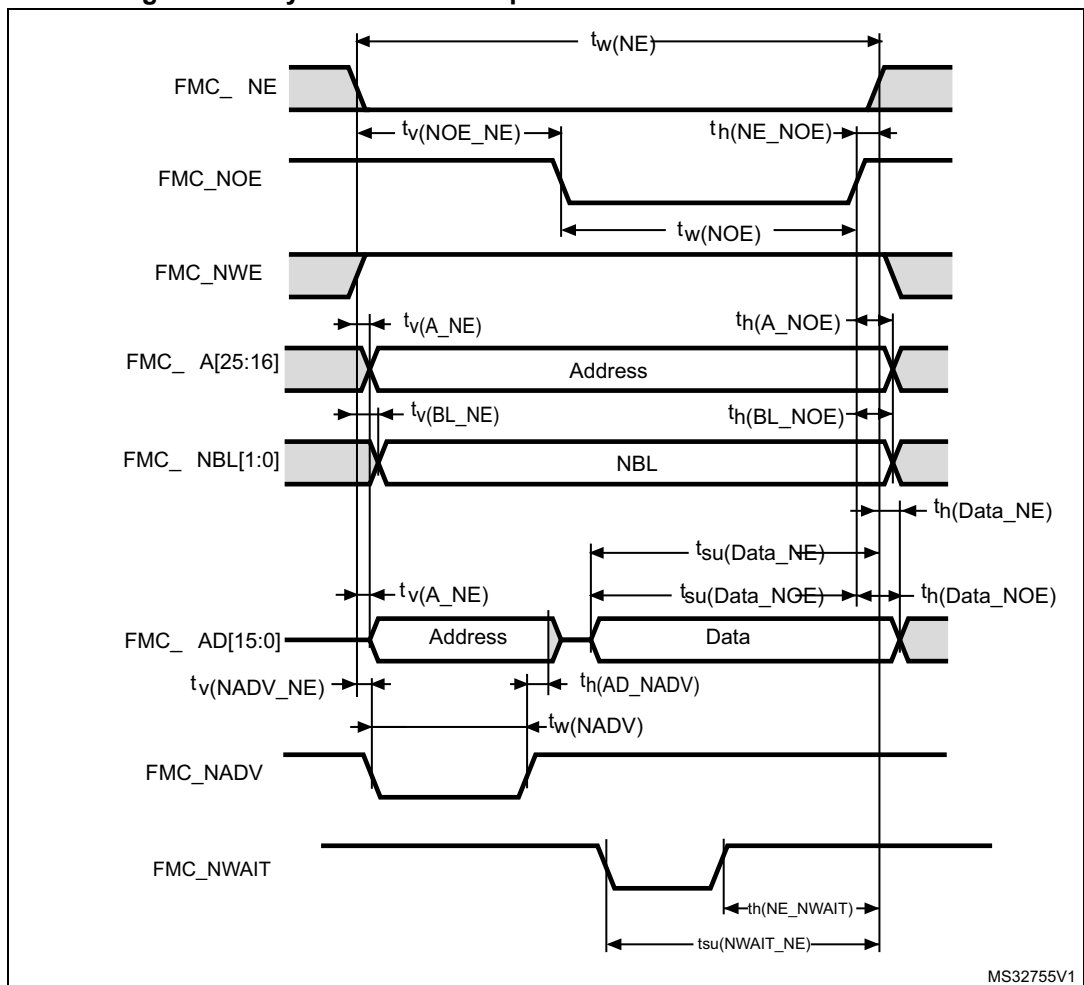

**Table 68. Asynchronous multiplexed PSRAM/NOR read timings<sup>(1)</sup>**

Symbol	Parameter	Min	Max	Unit
$t_{w(NE)}$	FMC_NE low time	$3T_{fmc\_ker\_ck} ? 1$	$3T_{fmc\_ker\_ck} + 1$	ns
$t_{v(NO\_NE)}$	FMC_NEx low to FMC_NOE low	$2T_{fmc\_ker\_ck}$	$2T_{fmc\_ker\_ck} + 0.5$	
$t_{tw(NO\_E)}$	FMC_NOE low time	$T_{fmc\_ker\_ck} ? 1$	$T_{fmc\_ker\_ck} + 1$	
$t_{h(NE\_NOE)}$	FMC_NOE high to FMC_NE high hold time	0	-	
$t_{v(A\_NE)}$	FMC_NEx low to FMC_A valid	-	0.5	
$t_{v(NADV\_NE)}$	FMC_NEx low to FMC_NADV low	0	0.5	
$t_{w(NADV)}$	FMC_NADV low time	$T_{fmc\_ker\_ck} ? 0.5$	$T_{fmc\_ker\_ck} + 1$	
$t_{h(AD\_NADV)}$	FMC_AD(address) valid hold time after FMC_NADV high	$T_{fmc\_ker\_ck} + 0.5$	-	
$t_{h(A\_NOE)}$	Address hold time after FMC_NOE high	$T_{fmc\_ker\_ck} ? 0.5$	-	
$t_{h(BL\_NOE)}$	FMC_BL time after FMC_NOE high	0	-	
$t_{v(BL\_NE)}$	FMC_NEx low to FMC_BL valid	-	0.5	
$t_{su(Data\_NE)}$	Data to FMC_NEx high setup time	$T_{fmc\_ker\_ck} ? 2$	-	
$t_{su(Data\_NOE)}$	Data to FMC_NOE high setup time	$T_{fmc\_ker\_ck} ? 2$	-	
$t_{h(Data\_NE)}$	Data hold time after FMC_NEx high	0	-	
$t_{h(Data\_NOE)}$	Data hold time after FMC_NOE high	0	-	

1. Guaranteed by characterization results.

**Table 69. Asynchronous multiplexed PSRAM/NOR read-NWAIT timings<sup>(1)</sup>**

Symbol	Parameter	Min	Max	Unit
$t_{w(NE)}$	FMC_NE low time	$8T_{fmc\_ker\_ck} ? 1$	$8T_{fmc\_ker\_ck}$	ns
$t_{w(NO\_E)}$	FMC_NWE low time	$5T_{fmc\_ker\_ck} ? 1.5$	$5T_{fmc\_ker\_ck} + 0.5$	
$t_{su(NWAIT\_NE)}$	FMC_NWAIT valid before FMC_NEx high	$5T_{fmc\_ker\_ck} + 3$	-	
$t_{h(NE\_NWAIT)}$	FMC_NEx hold time after FMC_NWAIT invalid	$4T_{fmc\_ker\_ck}$	-	

1. Guaranteed by characterization results.

Figure 23. Asynchronous multiplexed PSRAM/NOR write waveforms

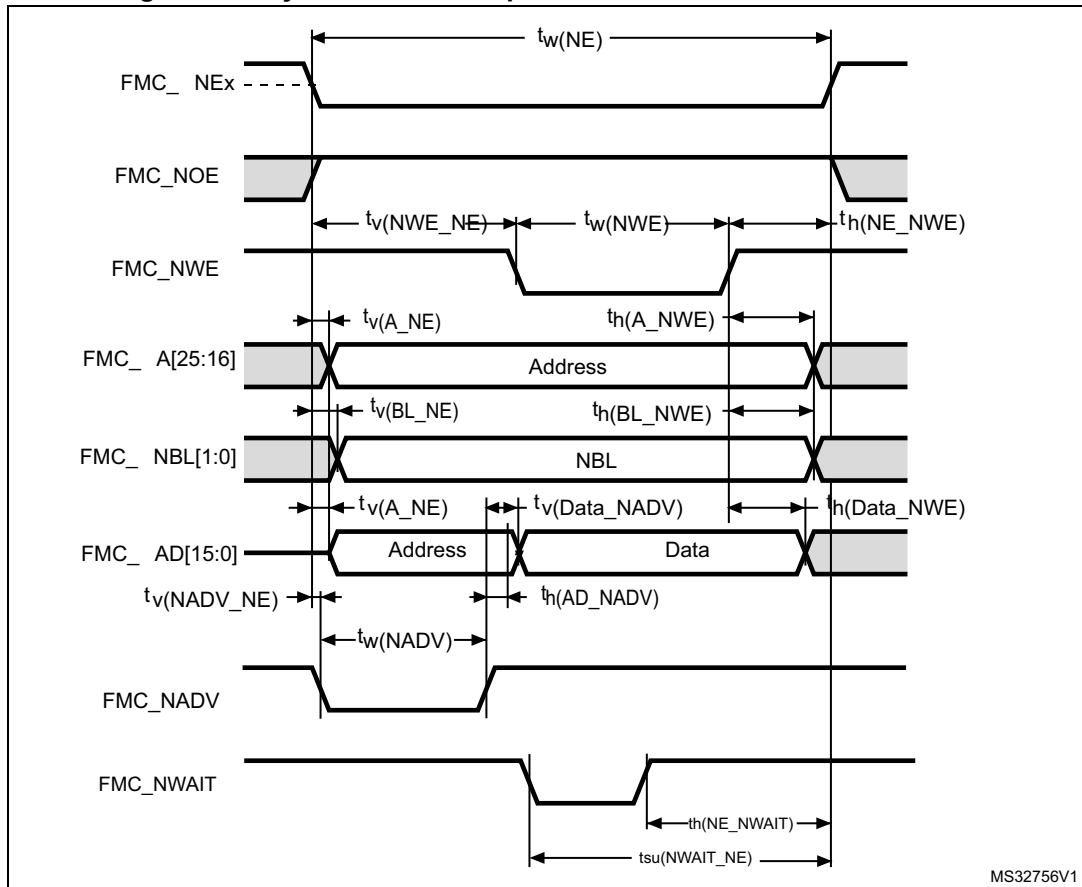

MS32756V1

Table 70. Asynchronous multiplexed PSRAM/NOR write timings<sup>(1)</sup>

Symbol	Parameter	Min	Max	Unit
$t_{w(NE)}$	FMC_NE low time	$4T_{fmc\_ker\_c} ? 1$	$4T_{fmc\_ker\_ck}$	ns
$t_{v(NWE\_NE)}$	FMC_NEX low to FMC_NWE low	$T_{fmc\_ker\_c} ? 1$	$T_{fmc\_ker\_ck} + 0.5$	
$t_{w(NWE)}$	FMC_NWE low time	$2T_{fmc\_ker\_ck} ? 0.5$	$2T_{fmc\_ker\_ck} + 0.5$	
$t_{h(NE\_NWE)}$	FMC_NWE high to FMC_NE high hold time	$T_{fmc\_ker\_ck} ? 0.5$	-	
$t_{v(A\_NE)}$	FMC_NEX low to FMC_A valid	-	0	
$t_{v(NADV\_NE)}$	FMC_NEX low to FMC_NADV low	0	0.5	
$t_{w(NADV)}$	FMC_NADV low time	$T_{fmc\_ker\_ck}$	$T_{fmc\_ker\_ck} + 1$	
$t_{h(AD\_NADV)}$	FMC_AD(address) valid hold time after FMC_NADV high	$T_{fmc\_ker\_ck} + 0.5$	-	
$t_{h(A\_NWE)}$	Address hold time after FMC_NWE high	$T_{fmc\_ker\_ck} + 0.5$	-	
$t_{h(BL\_NWE)}$	FMC_BL hold time after FMC_NWE high	$T_{fmc\_ker\_ck} ? 0.5$	-	
$t_{v(BL\_NE)}$	FMC_NEX low to FMC_BL valid	-	0.5	
$t_{v(Data\_NADV)}$	FMC_NADV high to Data valid	-	$T_{fmc\_ker\_ck} + 2$	
$t_{h(Data\_NWE)}$	Data hold time after FMC_NWE high	$T_{fmc\_ker\_ck} + 0.5$	-	

1. Guaranteed by characterization results.

**Table 71. Asynchronous multiplexed PSRAM/NOR write-NWAIT timings<sup>(1)</sup>**

Symbol	Parameter	Min	Max	Unit
$t_{w(NE)}$	FMC_NE low time	$9T_{fmc\_ker\_ck} - 1$	$9T_{fmc\_ker\_ck}$	ns
$t_{w(NWE)}$	FMC_NWE low time	$7T_{fmc\_ker\_ck} - 0.5$	$7T_{fmc\_ker\_ck} + 0.5$	
$t_{su(NWAIT\_NE)}$	FMC_NWAIT valid before FMC_NEx high	$6T_{fmc\_ker\_ck} + 3$	-	
$t_{h(NE\_NWAIT)}$	FMC_NEx hold time after FMC_NWAIT invalid	$4T_{fmc\_ker\_ck}$	-	

1. Guaranteed by characterization results.

### Synchronous waveforms and timings

Figure 24 through Figure 27 represent synchronous waveforms and Table 72 through Table 75 provide the corresponding timings. The results shown in these tables are obtained with the following FMC configuration:

- BurstAccessMode = FMC\_BurstAccessMode\_Enable
- MemoryType = FMC\_MemoryType\_CRAM
- WriteBurst = FMC\_WriteBurst\_Enable
- CLKDivision = 1
- DataLatency = 1 for NOR Flash; DataLatency = 0 for PSRAM

In all the timing tables, the  $T_{fmc\_ker\_ck}$  is the  $f_{fmc\_ker\_ck}$  clock period, with the following FMC\_CLK maximum values:

- For  $2.7\text{ V} < V_{DD} < 3.6\text{ V}$ , FMC\_CLK = 100 MHz at 20 pF
- For  $1.8\text{ V} < V_{DD} < 1.9\text{ V}$ , FMC\_CLK = 100 MHz at 20 pF
- For  $1.62\text{ V} < V_{DD} < 1.8\text{ V}$ , FMC\_CLK = 100 MHz at 15 pF



Figure 24. Synchronous multiplexed NOR/PSRAM read timings

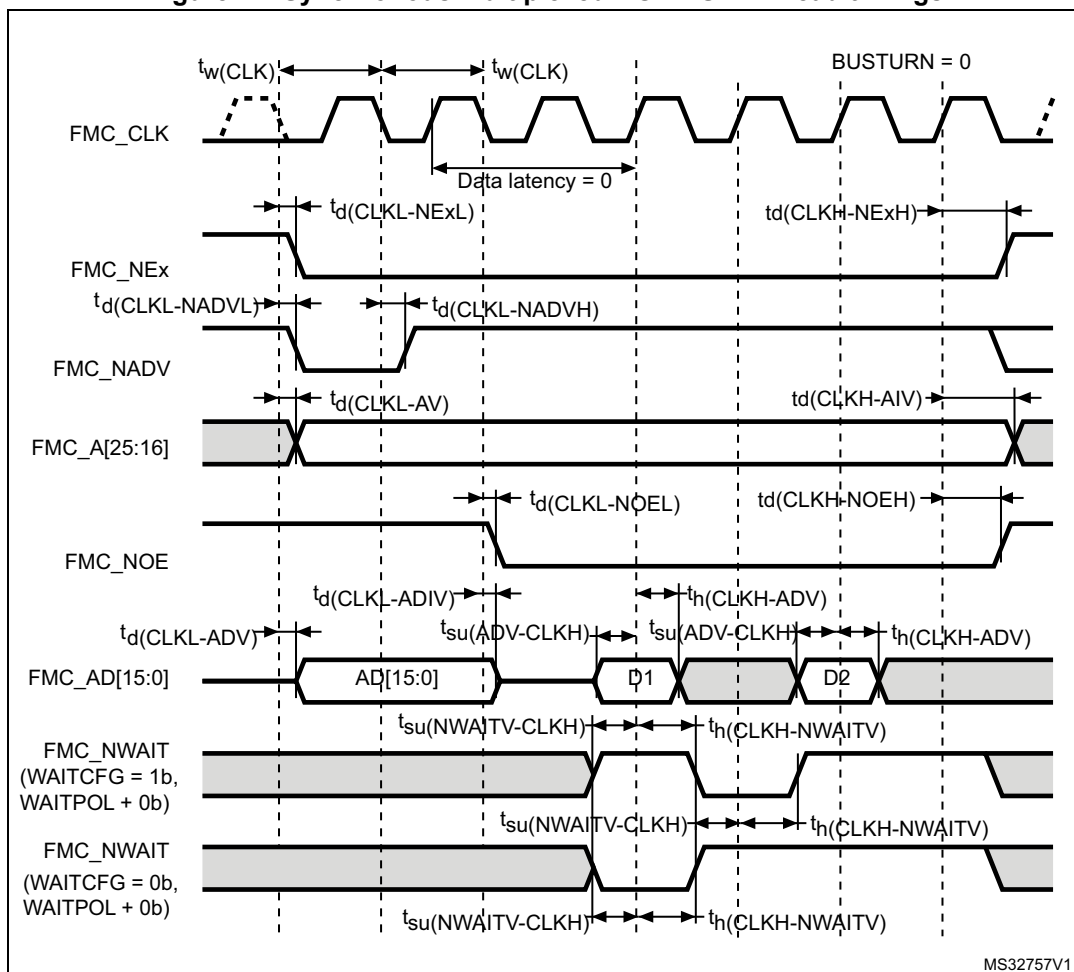

Table 72. Synchronous multiplexed NOR/PSRAM read timings<sup>(1)</sup>

Symbol	Parameter	Min	Max	Unit
$t_{w(\text{CLK})}$	FMC_CLK period	$2T_{\text{fmc\_ker\_ck}} ? 1$	-	ns
$t_{d(\text{CLKL-NEXL})}$	FMC_CLK low to FMC_NEx low (x=0..2)	-	1	
$t_{d(\text{CLKH-NEXH})}$	FMC_CLK high to FMC_NEx high (x= 0...2)	$T_{\text{fmc\_ker\_ck}} + 0.5$	-	
$t_{d(\text{CLKL-NADVL})}$	FMC_CLK low to FMC_NADV low	-	1.	
$t_{d(\text{CLKL-NADVH})}$	FMC_CLK low to FMC_NADV high	0	-	
$t_{d(\text{CLKL-AV})}$	FMC_CLK low to FMC_Ax valid (x=16...25)	-	2.5	
$t_{d(\text{CLKH-AIV})}$	FMC_CLK high to FMC_Ax invalid (x=16...25)	$T_{\text{fmc\_ker\_ck}}$	-	
$t_{d(\text{CLKL-NOEL})}$	FMC_CLK low to FMC_NOE low	-	1.5	
$t_{d(\text{CLKH-NOEH})}$	FMC_CLK high to FMC_NOE high	$T_{\text{fmc\_ker\_ck}} ? 0.5$	-	
$t_{d(\text{CLKL-ADV})}$	FMC_CLK low to FMC_AD[15:0] valid	-	3	
$t_{d(\text{CLKL-ADIV})}$	FMC_CLK low to FMC_AD[15:0] invalid	0	-	
$t_{su(\text{ADV-CLKH})}$	FMC_A/D[15:0] valid data before FMC_CLK high	2	-	
$t_h(\text{CLKH-ADV})$	FMC_A/D[15:0] valid data after FMC_CLK high	1	-	
$t_{su(\text{NWAIT-CLKH})}$	FMC_NWAIT valid before FMC_CLK high	2	-	
$t_h(\text{CLKH-NWAIT})$	FMC_NWAIT valid after FMC_CLK high	2	-	

1. Guaranteed by characterization results.

Figure 25. Synchronous multiplexed PSRAM write timings

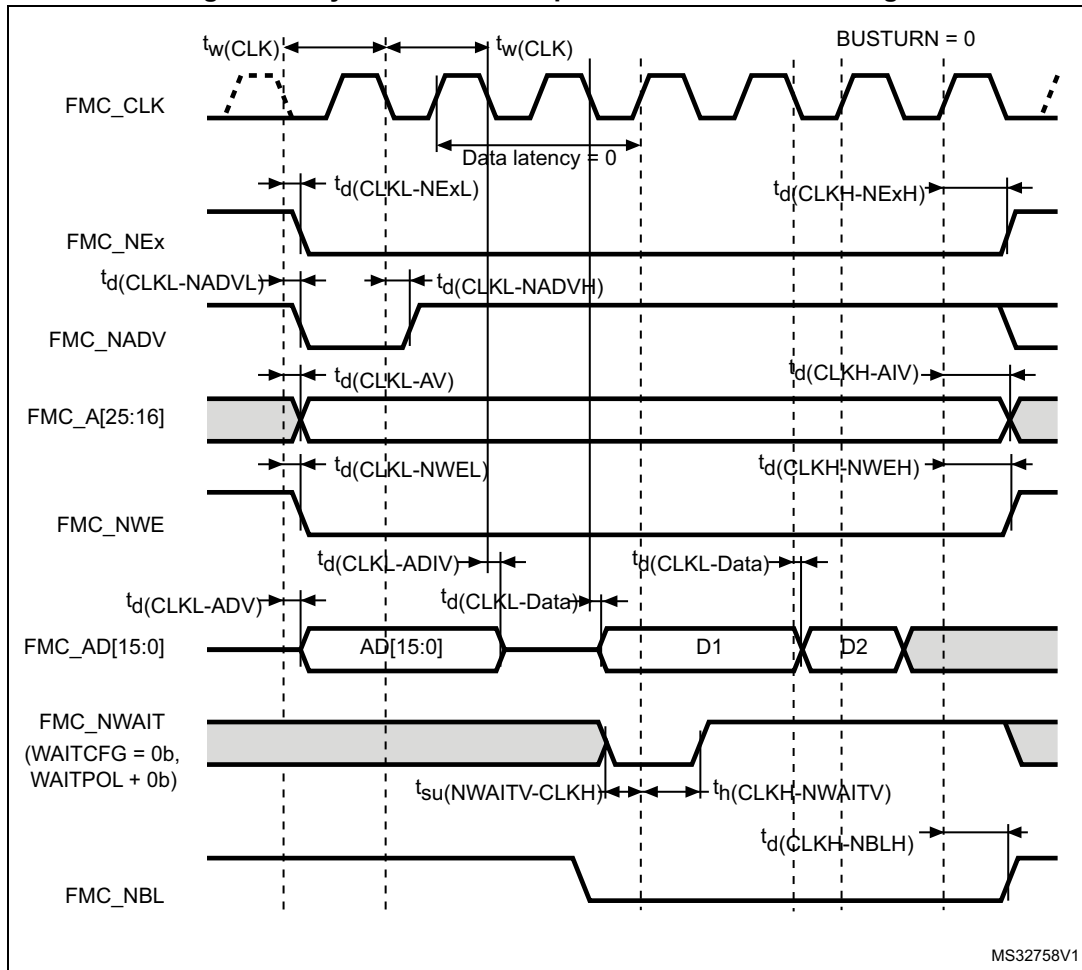

Table 73. Synchronous multiplexed PSRAM write timings<sup>(1)</sup>

Symbol	Parameter	Min	Max	Unit
$t_{w(\text{CLK})}$	FMC_CLK period	$2T_{\text{fmc\_ker\_ck}} ? 1$	-	ns
$t_{d(\text{CLKL-NExL})}$	FMC_CLK low to FMC_NEx low (x=0..2)	-	1	
$t_{d(\text{CLKH-NExH})}$	FMC_CLK high to FMC_NEx high (x= 0...2)	$T_{\text{fmc\_ker\_ck}} + 0.5$	-	
$t_{d(\text{CLKL-NADV})}$	FMC_CLK low to FMC_NADV low	-	1.5	
$t_{d(\text{CLKL-NADVH})}$	FMC_CLK low to FMC_NADV high	0	-	
$t_{d(\text{CLKL-AV})}$	FMC_CLK low to FMC_Ax valid (x=16...25)	-	2	
$t_{d(\text{CLKH-AIV})}$	FMC_CLK high to FMC_Ax invalid (x=16...25)	$T_{\text{fmc\_ker\_ck}}$	-	
$t_{d(\text{CLKL-NWEL})}$	FMC_CLK low to FMC_NWE low	-	1.5	
$t_{d(\text{CLKH-NWEH})}$	FMC_CLK high to FMC_NWE high	$T_{\text{fmc\_ker\_ck}} + 0.5$	-	
$t_{d(\text{CLKL-ADV})}$	FMC_CLK low to FMC_AD[15:0] valid	-	2.5	
$t_{d(\text{CLKL-ADIV})}$	FMC_CLK low to FMC_AD[15:0] invalid	0	-	
$t_{d(\text{CLKL-DATA})}$	FMC_A/D[15:0] valid data after FMC_CLK low	-	2.5	
$t_{d(\text{CLKL-NBLL})}$	FMC_CLK low to FMC_NBL low	-	2	
$t_{d(\text{CLKH-NBLH})}$	FMC_CLK high to FMC_NBL high	$T_{\text{fmc\_ker\_ck}} + 0.5$	-	
$t_{su(\text{NWAIT-CLKH})}$	FMC_NWAIT valid before FMC_CLK high	2	-	
$t_{h(\text{CLKH-NWAIT})}$	FMC_NWAIT valid after FMC_CLK high	2	-	

1. Guaranteed by characterization results.

Figure 26. Synchronous non-multiplexed NOR/PSRAM read timings

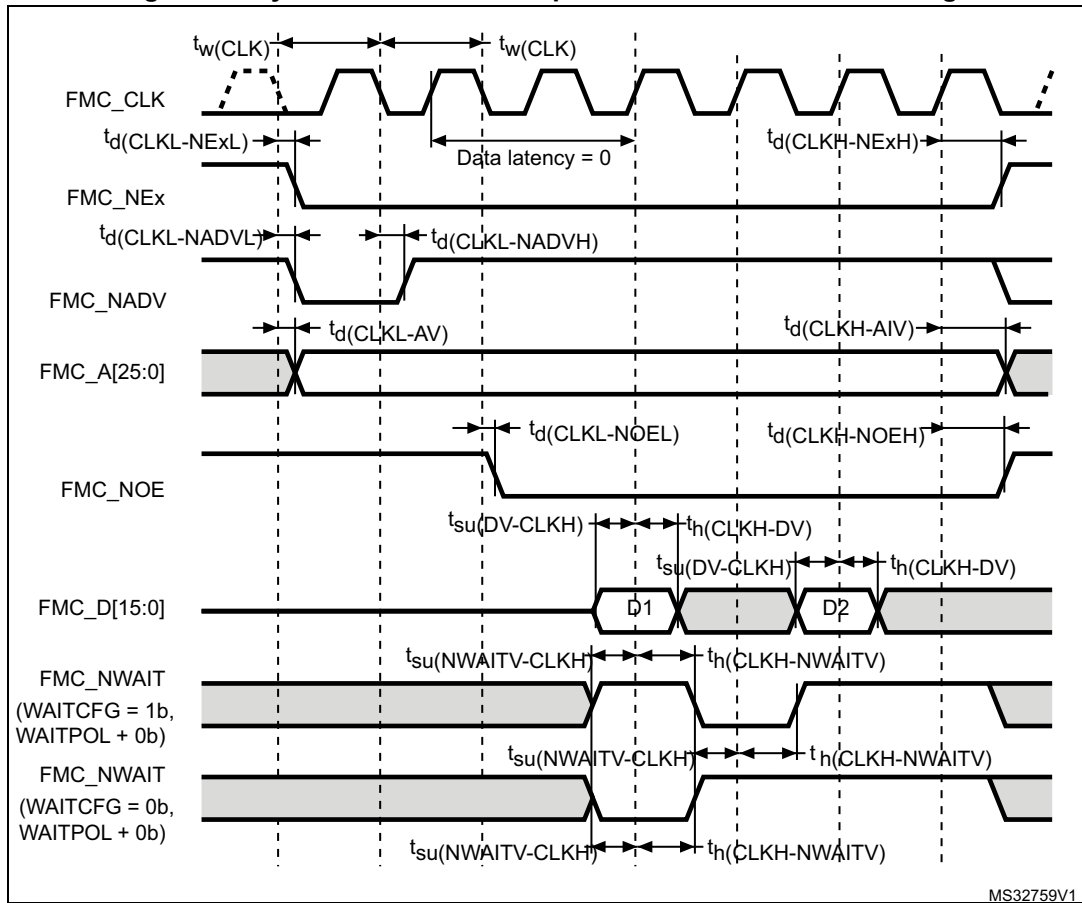
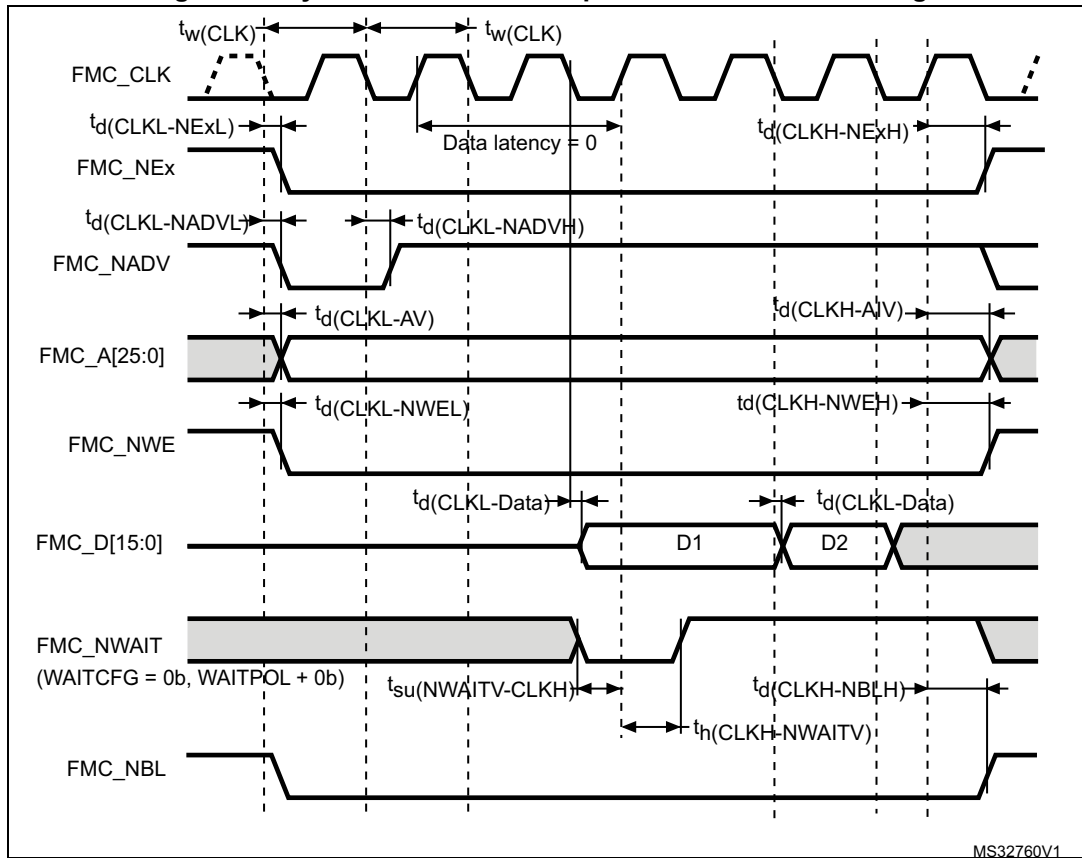

Table 74. Synchronous non-multiplexed NOR/PSRAM read timings<sup>(1)</sup>

Symbol	Parameter	Min	Max	Unit
$t_w(\text{CLK})$	FMC_CLK period	$2T_{\text{fmc\_ker\_ck}} \cdot 1$	-	ns
$t_d(\text{CLKL-NExL})$	FMC_CLK low to FMC_NEx low (x=0..2)	-	2	
$t_d(\text{CLKH-NExH})$	FMC_CLK high to FMC_NEx high (x= 0...2)	$T_{\text{fmc\_ker\_ck}} + 0.5$	-	
$t_d(\text{CLKL-NADV})$	FMC_CLK low to FMC_NADV low	-	0.5	
$t_d(\text{CLKL-NADVH})$	FMC_CLK low to FMC_NADV high	0	-	
$t_d(\text{CLKL-AV})$	FMC_CLK low to FMC_Ax valid (x=16...25)	-	2	
$t_d(\text{CLKH-AIV})$	FMC_CLK high to FMC_Ax invalid (x=16...25)	$T_{\text{fmc\_ker\_ck}}$	-	
$t_d(\text{CLKL-NOEL})$	FMC_CLK low to FMC_NOE low	-	1.5	
$t_d(\text{CLKH-NOEH})$	FMC_CLK high to FMC_NOE high	$T_{\text{fmc\_ker\_ck}} + 0.5$	-	
$t_{su}(\text{DV-CLKH})$	FMC_D[15:0] valid data before FMC_CLK high	2	-	
$t_h(\text{CLKH-DV})$	FMC_D[15:0] valid data after FMC_CLK high	1	-	
$t_{su}(\text{NWAITV-CLKH})$	FMC_NWAIT valid before FMC_CLK high	2	-	
$t_h(\text{CLKH-NWAITV})$	FMC_NWAIT valid after FMC_CLK high	2	-	

1. Guaranteed by characterization results.

Figure 27. Synchronous non-multiplexed PSRAM write timings



MS32760V1

Table 75. Synchronous non-multiplexed PSRAM write timings<sup>(1)</sup>

Symbol	Parameter	Min	Max	Unit
$t_{(CLK)}$	FMC_CLK period	$2T_{fmc\_ker\_ck} ? 1$	-	ns
$t_{d(CLKL-NExL)}$	FMC_CLK low to FMC_NEx low (x=0..2)	-	2	
$t_{(CLKH-NExH)}$	FMC_CLK high to FMC_NEx high (x= 0...2)	$T_{fmc\_ker\_ck} + 0.5$	-	
$t_{d(CLKL-NADV)}$	FMC_CLK low to FMC_NADV low	-	0.5	
$t_{d(CLKL-NADVH)}$	FMC_CLK low to FMC_NADV high	0	-	
$t_{d(CLKL-AV)}$	FMC_CLK low to FMC_Ax valid (x=16...25)	-	2	
$t_{d(CLKH-AIV)}$	FMC_CLK high to FMC_Ax invalid (x=16...25)	$T_{fmc\_ker\_ck}$	-	
$t_{d(CLKL-NWEL)}$	FMC_CLK low to FMC_NWE low	-	1.5	
$t_{d(CLKH-NWEH)}$	FMC_CLK high to FMC_NWE high	$T_{fmc\_ker\_ck} + 1$	-	
$t_{d(CLKL-Data)}$	FMC_D[15:0] valid data after FMC_CLK low	-	3.5	
$t_{d(CLKL-NBLL)}$	FMC_CLK low to FMC_NBL low	-	2	
$t_{d(CLKH-NBLH)}$	FMC_CLK high to FMC_NBL high	$T_{fmc\_ker\_ck} + 1$	-	
$t_{su(NWAITV-CLKH)}$	FMC_NWAIT valid before FMC_CLK high	2	-	
$t_{h(CLKH-NWAIT)}$	FMC_NWAIT valid after FMC_CLK high	2	-	

1. Guaranteed by characterization results.

**NAND controller waveforms and timings**

Figure 28 through Figure 31 represent synchronous waveforms, and Table 76 and Table 77 provide the corresponding timings. The results shown in this table are obtained with the following FMC configuration:

- COM.FMC\_SetupTime = 0x01
- COM.FMC\_WaitSetupTime = 0x03
- COM.FMC\_HoldSetupTime = 0x02
- COM.FMC\_HiZSetupTime = 0x01
- ATT.FMC\_SetupTime = 0x01
- ATT.FMC\_WaitSetupTime = 0x03
- ATT.FMC\_HoldSetupTime = 0x02
- ATT.FMC\_HiZSetupTime = 0x01
- Bank = FMC\_Bank\_NAND
- MemoryDataWidth = FMC\_MemoryDataWidth\_16b
- ECC = FMC\_ECC\_Enable
- ECCPageSize = FMC\_ECCPageSize\_512Bytes
- TCLRSetupTime = 0
- TARSetupTime = 0
- C<sub>L</sub> = 30 pF

In all timing tables, the T<sub>fmc\_ker\_ck</sub> is the fmc\_ker\_ck clock period.

**Figure 28. NAND controller waveforms for read access**

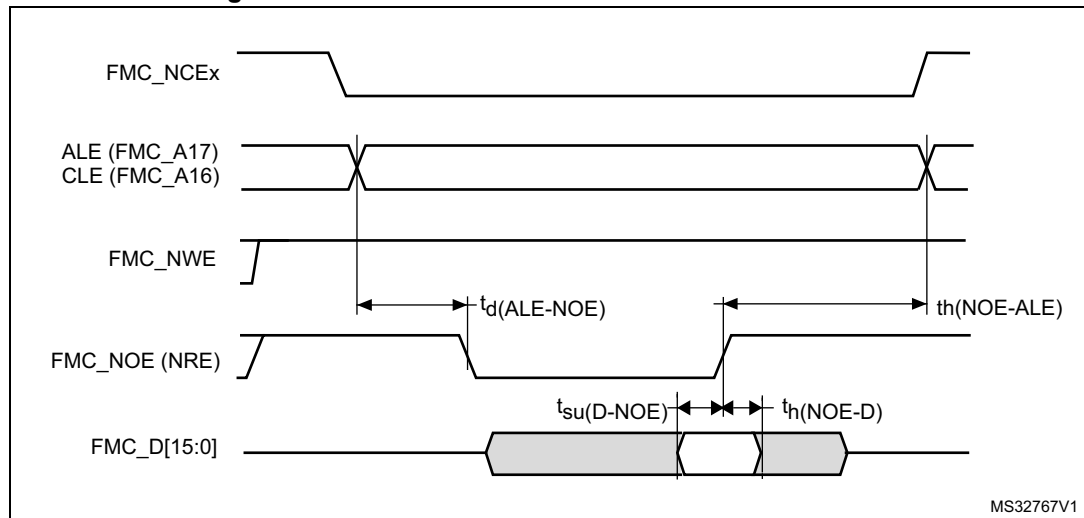
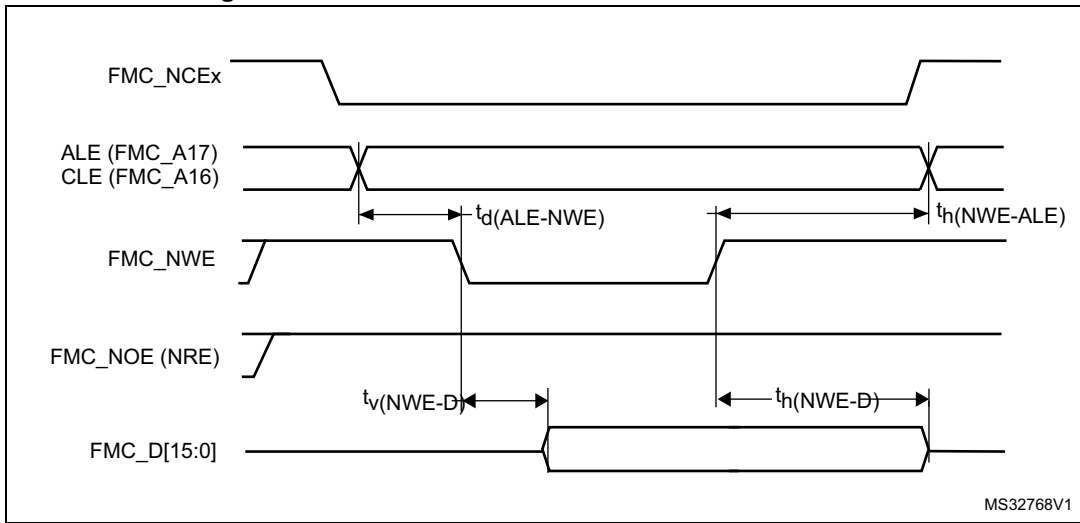
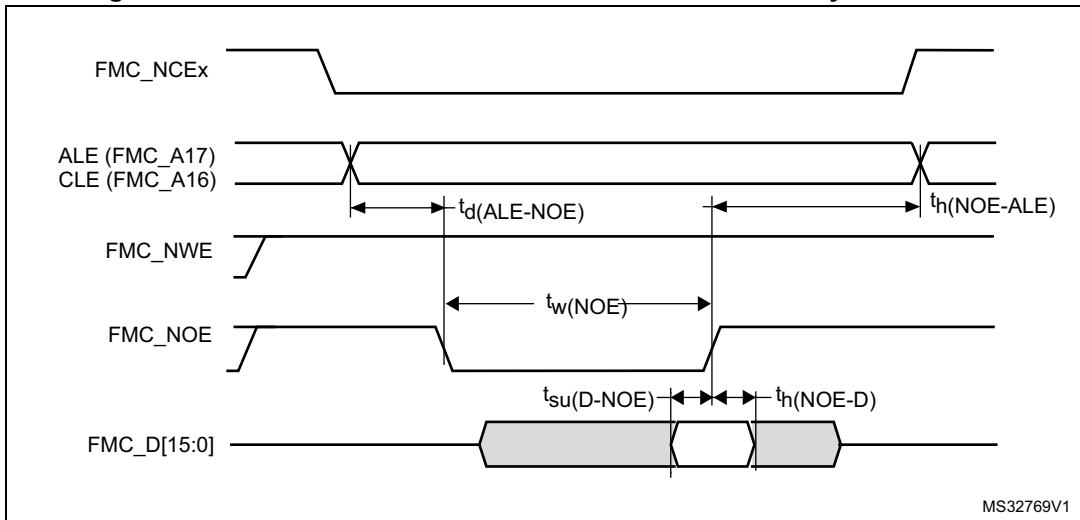

Figure 29. NAND controller waveforms for write access



MS32768V1

Figure 30. NAND controller waveforms for common memory read access



MS32769V1



Figure 31. NAND controller waveforms for common memory write access

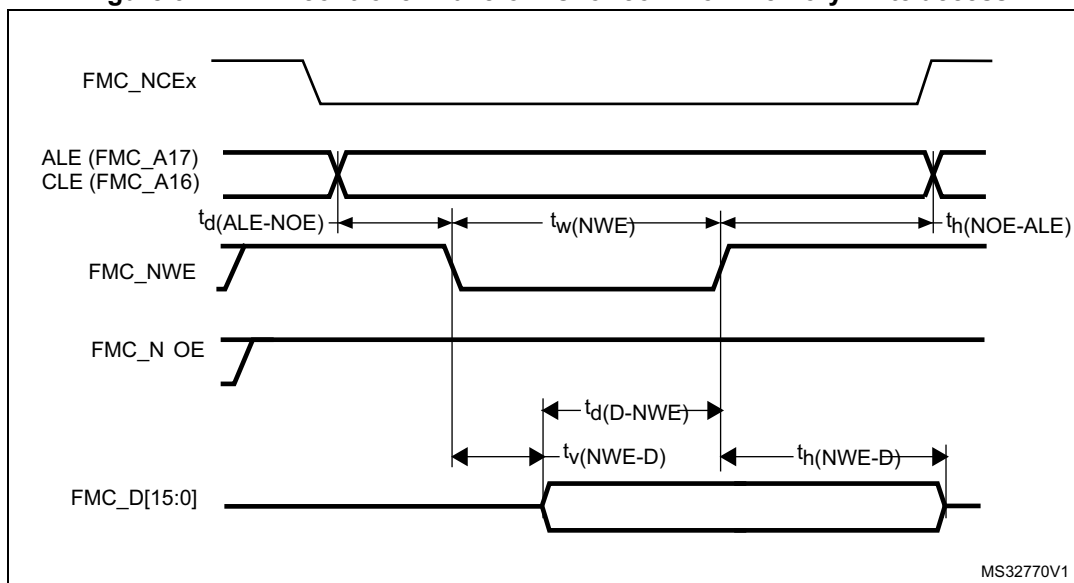

Table 76. Switching characteristics for NAND Flash read cycles<sup>(1)</sup>

Symbol	Parameter	Min	Max	Unit
$t_w(\text{NOE})$	FMC_NOE low width	$4T_{\text{fmc\_ker\_ck}} - 0.5$	$4T_{\text{fmc\_ker\_ck}} + 0.5$	ns
$t_{\text{su}}(\text{D-NOE})$	FMC_D[15-0] valid data before FMC_NOE high	8	-	
$t_h(\text{NOE-D})$	FMC_D[15-0] valid data after FMC_NOE high	0	-	
$t_d(\text{ALE-NOE})$	FMC_ALE valid before FMC_NOE low	-	$3T_{\text{fmc\_ker\_ck}} + 1$	
$t_h(\text{NOE-ALE})$	FMC_NWE high to FMC_ALE invalid	$4T_{\text{fmc\_ker\_ck}} ? 2$	-	

1. Guaranteed by characterization results.

Table 77. Switching characteristics for NAND Flash write cycles<sup>(1)</sup>

Symbol	Parameter	Min	Max	Unit
$t_w(\text{NWE})$	FMC_NWE low width	$4T_{\text{fmc\_ker\_ck}} ? 0.5$	$4T_{\text{fmc\_ker\_ck}} + 0.5$	ns
$t_v(\text{NWE-D})$	FMC_NWE low to FMC_D[15-0] valid	0	-	
$t_h(\text{NWE-D})$	FMC_NWE high to FMC_D[15-0] invalid	$2T_{\text{fmc\_ker\_ck}} ? 0.5$	-	
$t_d(\text{D-NWE})$	FMC_D[15-0] valid before FMC_NWE high	$5T_{\text{fmc\_ker\_ck}} ? 1$	-	
$t_d(\text{ALE-NWE})$	FMC_ALE valid before FMC_NWE low	-	$3T_{\text{fmc\_ker\_ck}} + 0.5$	
$t_h(\text{NWE-ALE})$	FMC_NWE high to FMC_ALE invalid	$2T_{\text{fmc\_ker\_ck}} ? 1$	-	

1. Guaranteed by characterization results.

### SDRAM waveforms and timings

In all timing tables, the  $T_{fmc\_ker\_ck}$  is the  $fmc\_ker\_ck$  clock period, with the following FMC\_SDCLK maximum values:

- For  $1.8\text{ V} < V_{DD} < 3.6\text{ V}$ : FMC\_CLK = 100 MHz at 20 pF
- For  $1.62\text{ V} < V_{DD} < 1.8\text{ V}$ , FMC\_CLK = 100 MHz at 15 pF

Figure 32. SDRAM read access waveforms (CL = 1)

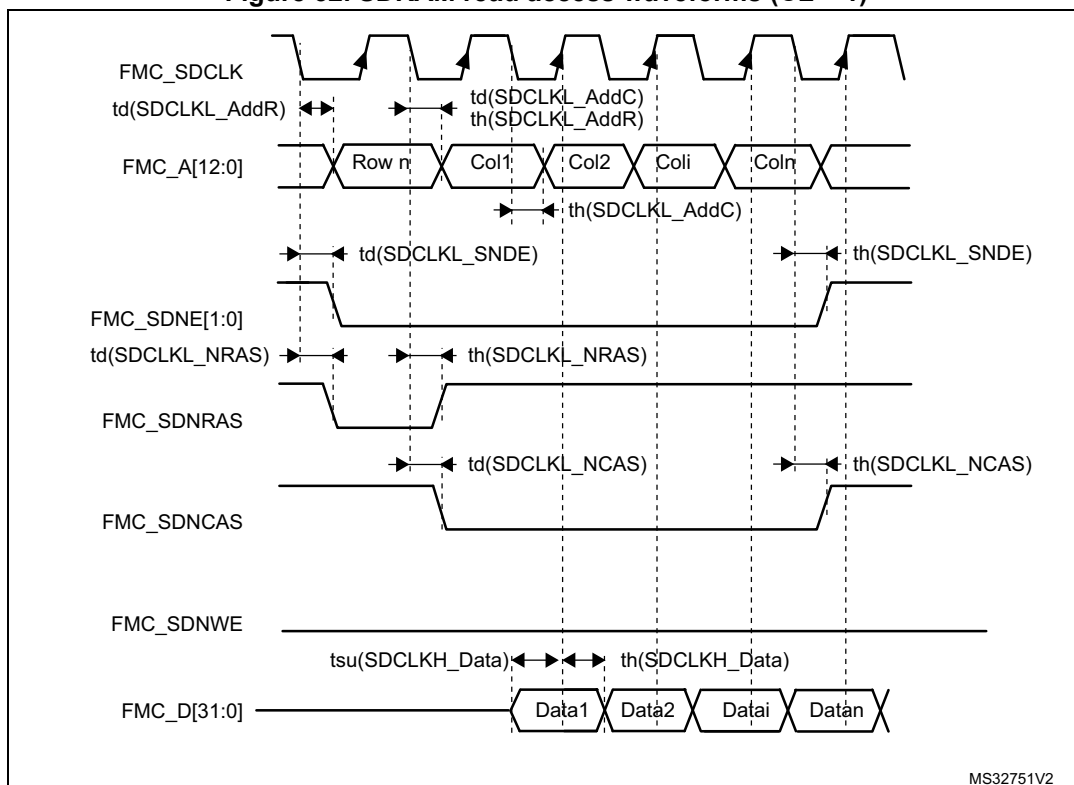

MS32751V2

Table 78. SDRAM read timings<sup>(1)</sup>

Symbol	Parameter	Min	Max	Unit
$t_w(\text{SDCLK})$	FMC_SDCLK period	$2T_{fmc\_ker\_ck} ? 1$	$2T_{fmc\_ker\_ck} + 0.5$	ns
$t_{su}(\text{SDCLKH\_Data})$	Data input setup time	2	-	
$t_h(\text{SDCLKH\_Data})$	Data input hold time	1	-	
$t_d(\text{SDCLKL\_Add})$	Address valid time	-	1.5	
$t_d(\text{SDCLKL-SDNE})$	Chip select valid time	-	1.5	
$t_h(\text{SDCLKL\_SDNE})$	Chip select hold time	0.5	-	
$t_d(\text{SDCLKL\_SDNRAS})$	SDNRAS valid time	-	1	
$t_h(\text{SDCLKL\_SDNRAS})$	SDNRAS hold time	0.5	-	
$t_d(\text{SDCLKL\_SDNCAS})$	SDNCAS valid time	-	0.5	
$t_h(\text{SDCLKL\_SDNCAS})$	SDNCAS hold time	0	-	

1. Guaranteed by characterization results.

Table 79. LPSDR SDRAM read timings<sup>(1)</sup>

Symbol	Parameter	Min	Max	Unit
$t_{W(SDCLK)}$	FMC_SDCLK period	$2T_{fmc\_ker\_ck} ? 1$	$2T_{fmc\_ker\_ck} + 0.5$	ns
$t_{su(SDCLKH\_Data)}$	Data input setup time	2	-	
$t_{h(SDCLKH\_Data)}$	Data input hold time	1.5	-	
$t_d(SDCLKL\_Add)$	Address valid time	-	2.5	
$t_d(SDCLKL\_SDNE)$	Chip select valid time	-	2.5	
$t_h(SDCLKL\_SDNE)$	Chip select hold time	0	-	
$t_d(SDCLKL\_SDNRAS)$	SDNRAS valid time	-	0.5	
$t_h(SDCLKL\_SDNRAS)$	SDNRAS hold time	0	-	
$t_d(SDCLKL\_SDNCAS)$	SDNCAS valid time	-	1.5	
$t_h(SDCLKL\_SDNCAS)$	SDNCAS hold time	0	-	

1. Guaranteed by characterization results.

Figure 33. SDRAM write access waveforms

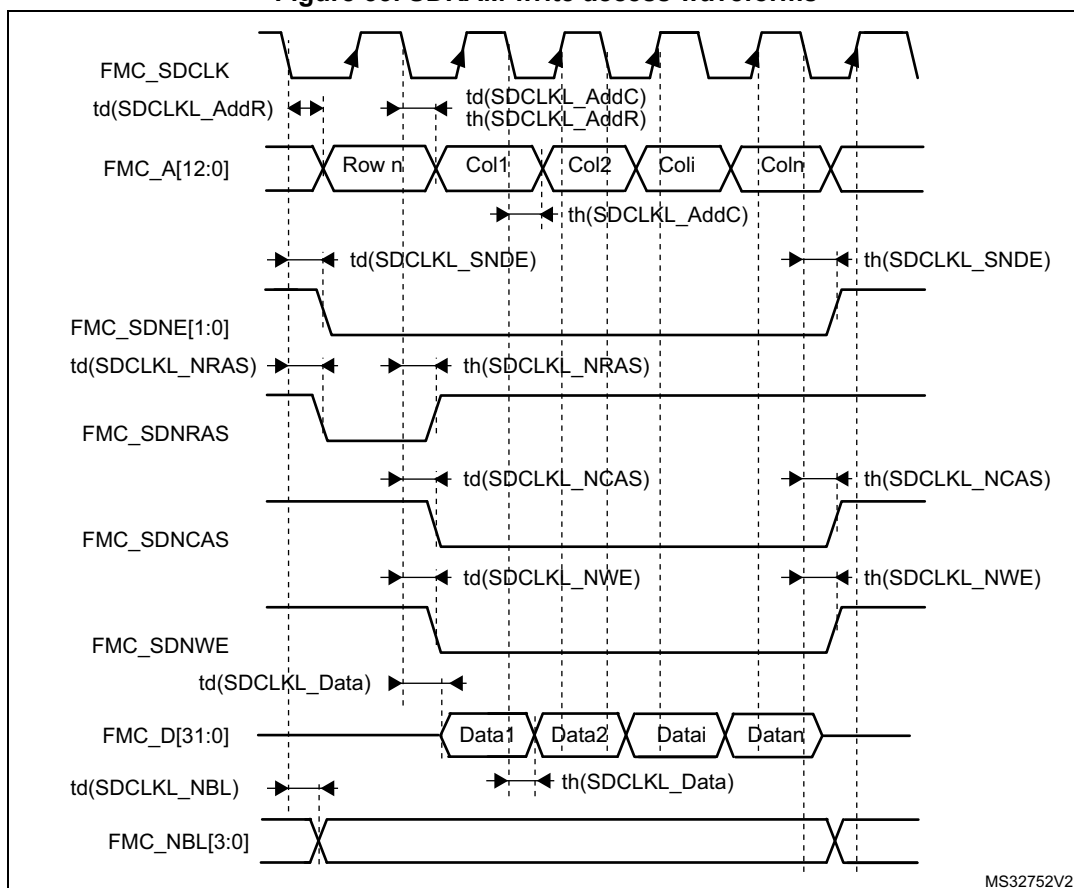

Table 80. SDRAM write timings<sup>(1)</sup>

Symbol	Parameter	Min	Max	Unit
$t_w(\text{SDCLK})$	FMC_SDCLK period	$2T_{\text{fmc\_ker\_ck}} ? 1$	$2T_{\text{fmc\_ker\_ck}} + 0.5$	ns
$t_d(\text{SDCLKL\_Data})$	Data output valid time	-	3	
$t_h(\text{SDCLKL\_Data})$	Data output hold time	0	-	
$t_d(\text{SDCLKL\_Add})$	Address valid time	-	1.5	
$t_d(\text{SDCLKL\_SDNWE})$	SDNWE valid time	-	1.5	
$t_h(\text{SDCLKL\_SDNWE})$	SDNWE hold time	0.5	-	
$t_d(\text{SDCLKL\_SDNE})$	Chip select valid time	-	1.5	
$t_h(\text{SDCLKL\_SDNE})$	Chip select hold time	0.5	-	
$t_d(\text{SDCLKL\_SDNRAS})$	SDNRAS valid time	-	1	
$t_h(\text{SDCLKL\_SDNRAS})$	SDNRAS hold time	0.5	-	
$t_d(\text{SDCLKL\_SDNCAS})$	SDNCAS valid time	-	1	
$t_d(\text{SDCLKL\_SDNCAS})$	SDNCAS hold time	0.5	-	

1. Guaranteed by characterization results.

Table 81. LPDDR SDRAM write timings<sup>(1)</sup>

Symbol	Parameter	Min	Max	Unit
$t_w(\text{SDCLK})$	FMC_SDCLK period	$2T_{\text{fmc\_ker\_ck}} ? 1$	$2T_{\text{fmc\_ker\_ck}} + 0.5$	ns
$t_d(\text{SDCLKL\_Data})$	Data output valid time	-	2.5	
$t_h(\text{SDCLKL\_Data})$	Data output hold time	0	-	
$t_d(\text{SDCLKL\_Add})$	Address valid time	-	2.5	
$t_d(\text{SDCLKL-SDNWE})$	SDNWE valid time	-	2.5	
$t_h(\text{SDCLKL-SDNWE})$	SDNWE hold time	0	-	
$t_d(\text{SDCLKL-SDNE})$	Chip select valid time	-	3	
$t_h(\text{SDCLKL-SDNE})$	Chip select hold time	0	-	
$t_d(\text{SDCLKL-SDNRAS})$	SDNRAS valid time	-	1.5	
$t_h(\text{SDCLKL-SDNRAS})$	SDNRAS hold time	0	-	
$t_d(\text{SDCLKL-SDNCAS})$	SDNCAS valid time	-	1.5	
$t_d(\text{SDCLKL-SDNCAS})$	SDNCAS hold time	0	-	

1. Guaranteed by characterization results.

### 6.3.18 Quad-SPI interface characteristics

Unless otherwise specified, the parameters given in [Table 82](#) and [Table 83](#) for QUADSPI are derived from tests performed under the ambient temperature,  $f_{\text{rcc\_c\_ck}}$  frequency and  $V_{\text{DD}}$  supply voltage conditions summarized in [Table 22: General operating conditions](#), with the following configuration:

- Output speed is set to  $\text{OSPEEDRy}[1:0] = 11$
- Measurement points are done at CMOS levels:  $0.5V_{\text{DD}}$
- I/O compensation cell enabled
- HSLV activated when  $V_{\text{DD}} \leq 2.7 \text{ V}$

Refer to [Section 6.3.15: I/O port characteristics](#) for more details on the input/output alternate function characteristics.

**Table 82. QUADSPI characteristics in SDR mode<sup>(1)</sup>**

Symbol	Parameter	Conditions	Min	Typ	Max	Unit
Fck1/T <sub>CK</sub>	QUADSPI clock frequency	2.7 V ≤ V <sub>DD</sub> < 3.6 V C <sub>L</sub> = 20 pF	-	-	133	MHz
		1.62 V < V <sub>DD</sub> < 3.6 V C <sub>L</sub> = 15 pF	-	-	100	
t <sub>w</sub> (CKH)	QUADSPI clock high and low time	-	T <sub>CK</sub> /2 - 0.5	-	T <sub>CK</sub> /2	ns
t <sub>w</sub> (CKL)			T <sub>CK</sub> /2	-	T <sub>CK</sub> /2 + 0.5	
t <sub>s</sub> (IN)	Data input setup time	-	1.5	-	-	
t <sub>h</sub> (IN)	Data input hold time		2	-	-	
t <sub>v</sub> (OUT)	Data output valid time	-	-	1.5	2	
t <sub>h</sub> (OUT)	Data output hold time	-	0.5	-	-	

1. Guaranteed by characterization results.

Table 83. QUADSPI characteristics in DDR mode<sup>(1)</sup>

Symbol	Parameter	Conditions	Min	Typ	Max	Unit
$F_{ck1/t(CK)}$	QUADSPI clock frequency	2.7 V < $V_{DD}$ < 3.6 V CL=20 pF	-	-	100	MHz
		1.62 V < $V_{DD}$ < 3.6 V CL=15 pF	-	-	100	
$t_{w(CKH)}$	QUADSPI clock high and low time	-	$T_{CK}/2 - 0.5$	-	$T_{CK}/2$	ns
$t_{w(CKL)}$			$T_{CK}/2$	-	$T_{CK}/2 + 0.5$	
$t_{sr(IN)}, t_{sf(IN)}$	Data input setup time	-	2	-	-	
$t_{hr(IN)}, t_{hf(IN)}$	Data input hold time	-	2	-	-	
$t_{vr(OUT)}, t_{vf(OUT)}$	Data output valid time	DHHC=0	-	3.5	4	
		DHHC=1 Pres=1, 2...	-	$T_{CK}/4 + 3.5$	$T_{CK}/4 + 4$	
$t_{hr(OUT)}, t_{hf(OUT)}$	Data output hold time	DHHC=0	3	-	-	
		DHHC=1 Pres=1, 2...	$T_{CK}/4 + 3$	-	-	

1. Guaranteed by characterization results.

Figure 34. Quad-SPI timing diagram - SDR mode

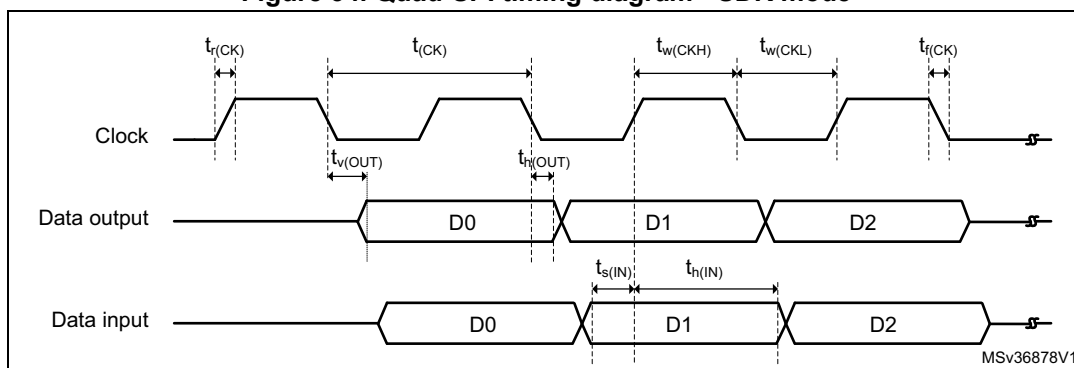
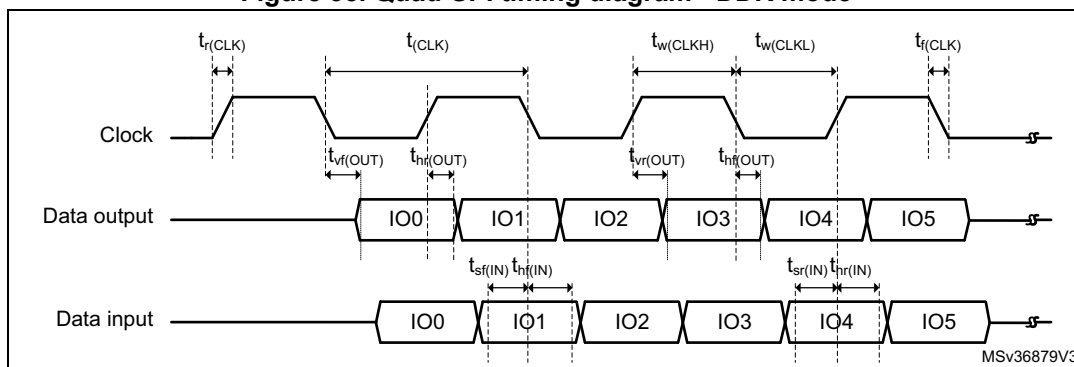

Figure 35. Quad-SPI timing diagram - DDR mode



### 6.3.19 Delay block (DLYB) characteristics

Unless otherwise specified, the parameters given in [Table 85](#) for the delay block are derived from tests performed under the ambient temperature,  $f_{\text{rcc\_c\_ck}}$  frequency and  $V_{\text{DD}}$  supply voltage summarized in [Table 22: General operating conditions](#).

**Table 84. Dynamics characteristics: Delay Block characteristics<sup>(1)</sup>**

Symbol	Parameter	Conditions	Min	Typ	Max	Unit
$t_{\text{init}}$	Initial delay	-	1400	2200	2400	ps
$t_{\Delta}$	Unit Delay	-	35	40	45	

1. Guaranteed by characterization results.

### 6.3.20 16-bit ADC characteristics

Unless otherwise specified, the parameters given in [Table 85](#) are derived from tests performed under the ambient temperature,  $f_{\text{PCLK2}}$  frequency and  $V_{\text{DDA}}$  supply voltage conditions summarized in [Table 22: General operating conditions](#).

**Table 85. ADC characteristics<sup>(1)</sup>**

Symbol	Parameter	Conditions	Min	Typ	Max	Unit	
$V_{\text{DDA}}$	Analog power supply	-	1.62	-	3.6	V	
$V_{\text{REF+}}$	Positive reference voltage	$V_{\text{DDA}} \geq 2 \text{ V}$	2	-	$V_{\text{DDA}}$		
$V_{\text{REF-}}$		Negative reference voltage	-	$V_{\text{SSA}}$			
$f_{\text{ADC}}$	ADC clock frequency	$2 \text{ V} \leq V_{\text{DDA}} \leq 3.3 \text{ V}$	BOOST = 1	-	-	36	MHz
			BOOST = 0	-	-	20	
$f_{\text{S}}$	Sampling rate for Fast channels, BOOST = 1, $f_{\text{ADC}} = 36 \text{ MHz}^{(2)}$	16-bit resolution	-	-	3.60 <sup>(2)</sup>	MSPS	
		14-bit resolution	-	-	4.00 <sup>(2)</sup>		
		12-bit resolution	-	-	4.50 <sup>(2)</sup>		
		10-bit resolution	-	-	5.00 <sup>(2)</sup>		
		8-bit resolution	-	-	6.00 <sup>(2)</sup>		
	Sampling rate for Fast channels, BOOST = 0, $f_{\text{ADC}} = 20 \text{ MHz}$	16-bit resolution	-	-	2.00 <sup>(2)</sup>		
		14-bit resolution	-	-	2.20 <sup>(2)</sup>		
		12-bit resolution	-	-	2.50 <sup>(2)</sup>		
		10-bit resolution	-	-	2.80 <sup>(2)</sup>		
		8-bit resolution	-	-	3.30 <sup>(2)</sup>		
	Sampling rate for Slow channels, BOOST = 0, $f_{\text{ADC}} = 10 \text{ MHz}$	16-bit resolution	-	-	1.00		
		14-bit resolution	-	-	1.00		
		12-bit resolution	-	-	1.00		
		10-bit resolution	-	-	1.00		
		8-bit resolution	-	-	1.00		

Table 85. ADC characteristics<sup>(1)</sup> (continued)

Symbol	Parameter	Conditions	Min	Typ	Max	Unit
f <sub>TRIG</sub>	External trigger frequency	f <sub>ADC</sub> = 36 MHz	-	-	3.6	MHz
		16-bit resolution	-	-	10	1/f <sub>ADC</sub>
V <sub>AIN</sub> <sup>(3)</sup>	Conversion voltage range	-	0	-	V <sub>REF+</sub>	V
V <sub>CMIV</sub>	Common mode input voltage	-	V <sub>REF/2</sub> -10%	V <sub>REF/2</sub>	V <sub>REF/2</sub> +10%	
R <sub>AIN</sub>	External input impedance	-	-	-	50	?
C <sub>ADC</sub>	Internal sample and hold capacitor	-	-	4	-	pF
t <sub>ADCREG-STUP</sub>	ADC LDO startup time	-	-	5	10	μs
t <sub>STAB</sub>	ADC power-up time	LDO already started	1			conversion cycle
t <sub>CAL</sub>	Offset and linearity calibration time	-	165,010			1/f <sub>ADC</sub>
t <sub>OFF_CAL</sub>	Offset calibration time	-	1,280			
t <sub>LATR</sub>	Trigger conversion latency for regular and injected channels without aborting the conversion	CKMODE = 00	1.5	2	2.5	
		CKMODE = 01	-	-	2	
		CKMODE = 10	-	-	2.25	
		CKMODE = 11	-	-	2.125	
t <sub>LATRINJ</sub>	Trigger conversion latency for regular and injected channels when a regular conversion is aborted	CKMODE = 00	2.5	3	3.5	
		CKMODE = 01	-	-	3	
		CKMODE = 10	-	-	3.25	
		CKMODE = 11	-	-	3.125	
t <sub>S</sub>	Sampling time	-	1.5	-	640.5	
t <sub>CONV</sub>	Total conversion time (including sampling time)	N-bit resolution	t <sub>S</sub> + 0.5 + N/2 (9 to 648 cycles in 14-bit mode)			

1. Guaranteed by design.

2. These values are obtained using the following formula:  $f_S = f_{ADC} / t_{CONV}$ , where  $f_{ADC} = 36$  MHz and  $t_{CONV} = 1.5$  cycle sampling time +  $t_{SAR}$  sampling time. Refer to the product reference manual for the value of  $t_{SAR}$  depending on resolution.

3. Depending on the package, V<sub>REF+</sub> can be internally connected to V<sub>DDA</sub> and V<sub>REF-</sub> to V<sub>SSA</sub>.



**Table 86. ADC accuracy<sup>(1)(2)(3)</sup>**

Symbol	Parameter	Conditions <sup>(4)</sup>		Min	Typ	Max	Unit
ET	Total unadjusted error	Single ended	BOOST = 1	-	±6	-	±LSB
			BOOST = 0	-	±8	-	
		Differential	BOOST = 1	-	±10	-	
			BOOST = 0	-	±16	-	
ED	Differential linearity error	Single ended	BOOST = 1	-	2	-	
			BOOST = 0	-	1	-	
		Differential	BOOST = 1	-	8	-	
			BOOST = 0	-	2	-	
EL	Integral linearity error	Single ended	BOOST = 1	-	±6	-	
			BOOST = 0	-	±4	-	
		Differential	BOOST = 1	-	±6	-	
			BOOST = 0	-	±4	-	
ENOB <sup>(5)</sup>	Effective number of bits (2 MSPS)	Single ended	BOOST = 1	-	11.6	-	bits
			BOOST = 0	-	12	-	
		Differential	BOOST = 1	-	13.3	-	
			BOOST = 0	-	13.5	-	
SINAD <sup>(5)</sup>	Signal-to-noise and distortion ratio (2 MSPS)	Single ended	BOOST = 1	-	71.6	-	dB
			BOOST = 0	-	74	-	
		Differential	BOOST = 1	-	81.83	-	
			BOOST = 0	-	83	-	
SNR <sup>(5)</sup>	Signal-to-noise ratio (2 MSPS)	Single ended	BOOST = 1	-	72	-	
			BOOST = 0	-	74	-	
		Differential	BOOST = 1	-	82	-	
			BOOST = 0	-	83	-	
THD <sup>(5)</sup>	Total harmonic distortion	Single ended	BOOST = 1	-	-78	-	
			BOOST = 0	-	-80	-	
		Differential	BOOST = 1	-	-90	-	
			BOOST = 0	-	-95	-	

1. Guaranteed by characterization for BGA packages, the values for LQFP packages might differ.
2. ADC DC accuracy values are measured after internal calibration.
3. The above table gives the ADC performance in 16-bit mode.
4. ADC clock frequency ≤ 36 MHz, 2 V ≤ V<sub>DDA</sub> ≤ 3.3 V, 1.6 V ≤ V<sub>REF</sub> ≤ V<sub>DDA</sub>, BOOSTEN (for I/O) = 1.
5. ENOB, SINAD, SNR and THD are specified for V<sub>DDA</sub> = V<sub>REF</sub> = 3.3 V.

Note: ADC accuracy vs. negative injection current: injecting a negative current on any analog input pins should be avoided as this significantly reduces the accuracy of the conversion

being performed on another analog input. It is recommended to add a Schottky diode (pin to ground) to analog pins which may potentially inject negative currents.

Any positive injection current within the limits specified for  $I_{INJ(PIN)}$  and  $\Sigma I_{INJ(PIN)}$  in [Section 6.3.14](#) does not affect the ADC accuracy.

**Figure 36. ADC accuracy characteristics (12-bit resolution)**

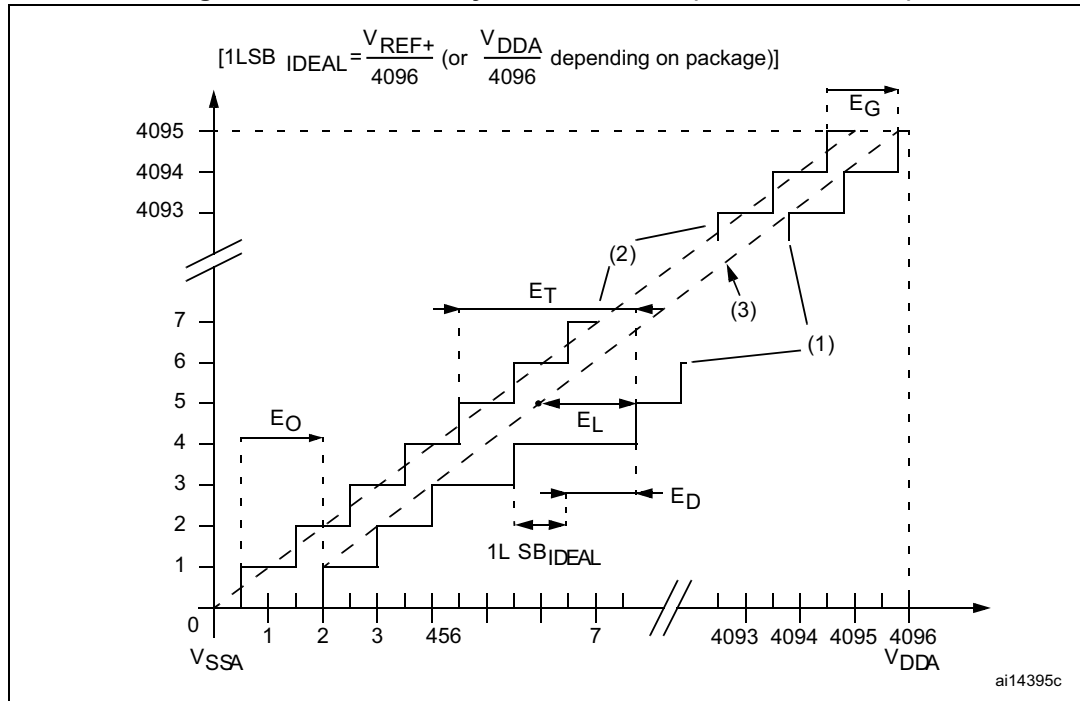

1. Example of an actual transfer curve.
2. Ideal transfer curve.
3. End point correlation line.
4.  $E_T$  = Total Unadjusted Error: maximum deviation between the actual and the ideal transfer curves.  
 $E_O$  = Offset Error: deviation between the first actual transition and the first ideal one.  
 $E_G$  = Gain Error: deviation between the last ideal transition and the last actual one.  
 $E_D$  = Differential Linearity Error: maximum deviation between actual steps and the ideal one.  
 $E_L$  = Integral Linearity Error: maximum deviation between any actual transition and the end point correlation line.

Figure 37. Typical connection diagram using the ADC

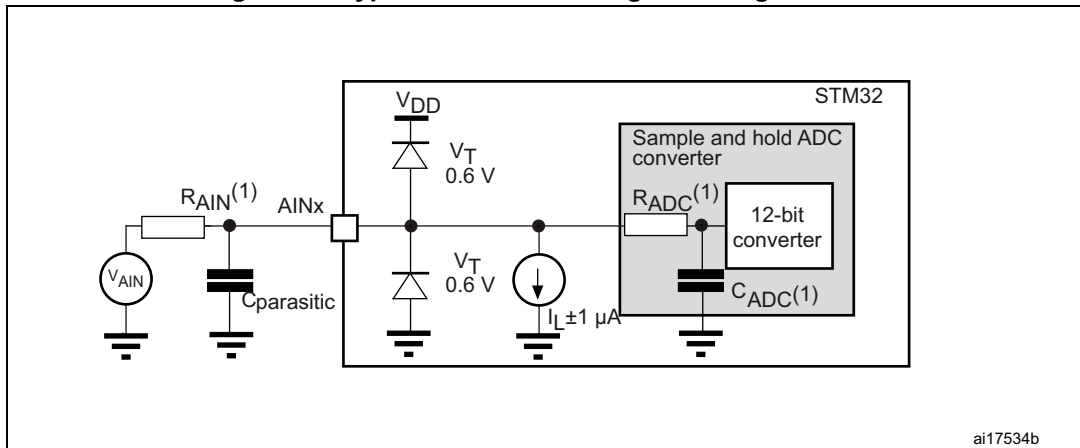

1. Refer to [Table 85](#) for the values of  $R_{AIN}$ ,  $R_{ADC}$  and  $C_{ADC}$ .
2.  $C_{parasitic}$  represents the capacitance of the PCB (dependent on soldering and PCB layout quality) plus the pad capacitance (roughly 5 pF). A high  $C_{parasitic}$  value downgrades conversion accuracy. To remedy this,  $f_{ADC}$  should be reduced.

**General PCB design guidelines**

Power supply decoupling should be performed as shown in [Figure 38](#) or [Figure 39](#), depending on whether  $V_{REF+}$  is connected to  $V_{DDA}$  or not. The 100 nF capacitors should be ceramic (good quality). They should be placed them as close as possible to the chip.

**Figure 38. Power supply and reference decoupling ( $V_{REF+}$  not connected to  $V_{DDA}$ )**

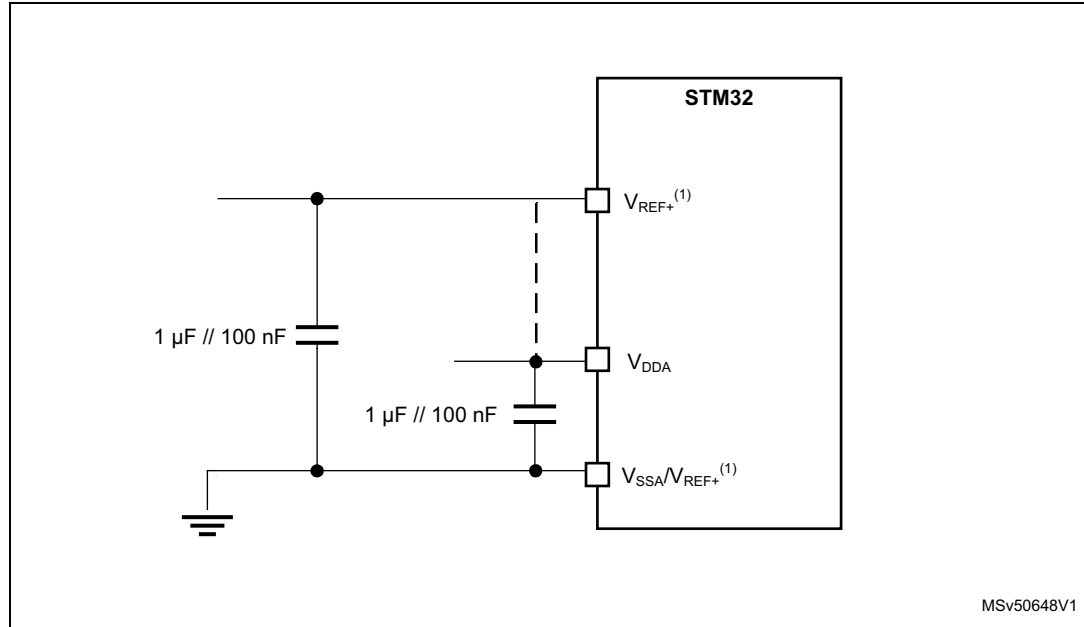

1.  $V_{REF+}$  input is available on all package whereas the  $V_{REF-}$  s available only on UFBGA176+25 and TFBGA240+25. When  $V_{REF-}$  is not available, it is internally connected to  $V_{DDA}$  and  $V_{SSA}$ .

**Figure 39. Power supply and reference decoupling ( $V_{REF+}$  connected to  $V_{DDA}$ )**

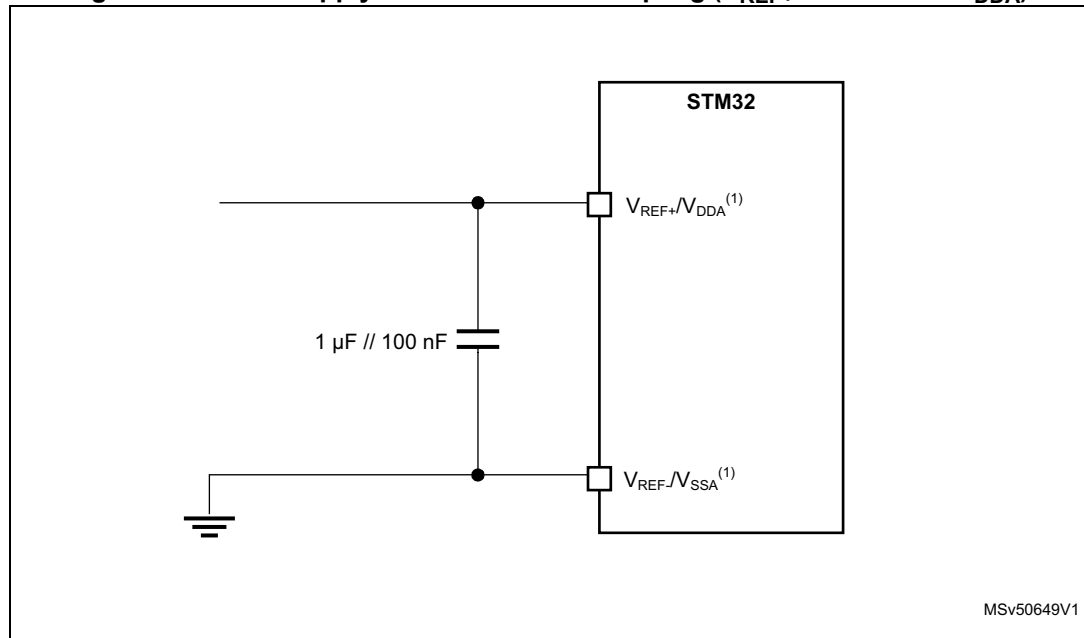

1.  $V_{REF+}$  input is available on all package whereas the  $V_{REF-}$  s available only on UFBGA176+25 and TFBGA240+25. When  $V_{REF-}$  is not available, it is internally connected to  $V_{DDA}$  and  $V_{SSA}$ .

## 6.3.21 DAC electrical characteristics

Table 87. DAC characteristics<sup>(1)</sup>

Symbol	Parameter	Conditions	Min	Typ	Max	Unit	
$V_{DDA}$	Analog supply voltage	-	1.8	3.3	3.6	V	
$V_{REF+}$	Positive reference voltage	-	1.80	-	$V_{DDA}$		
$V_{REF-}$	Negative reference voltage	-	-	$V_{SSA}$	-		
$R_L$	Resistive Load	DAC output buffer ON	connected to $V_{SSA}$	5	-	-	?
			connected to $V_{DDA}$	25	-	-	
$R_O^{(2)}$	Output Impedance	DAC output buffer OFF	10.3	13	16		
$R_{BON}$	Output impedance sample and hold mode, output buffer ON	DAC output buffer ON	$V_{DD} = 2.7\text{ V}$	-	-	1.6	?
			$V_{DD} = 2.0\text{ V}$	-	-	2.6	
$R_{BOFF}$	Output impedance sample and hold mode, output buffer OFF	DAC output buffer OFF	$V_{DD} = 2.7\text{ V}$	-	-	17.8	?
			$V_{DD} = 2.0\text{ V}$	-	-	18.7	
$C_L^{(2)}$	Capacitive Load	DAC output buffer OFF	-	-	50	pF	
$C_{SH}^{(2)}$		Sample and Hold mode	-	0.1	1	$\mu\text{F}$	
$V_{DAC\_OUT}$	Voltage on DAC_OUT output	DAC output buffer ON	0.2	-	$V_{REF+} - 0.2$	V	
		DAC output buffer OFF	0	-	$V_{REF+}$		
$t_{SETTLING}$	Settling time (full scale: for a 12-bit code transition between the lowest and the highest input codes when DAC_OUT reaches the final value of $\pm 0.5\text{LSB}$ , $\pm 1\text{LSB}$ , $\pm 2\text{LSB}$ , $\pm 4\text{LSB}$ , $\pm 8\text{LSB}$ )	Normal mode, DAC output buffer OFF, $\pm 1\text{LSB}$ $C_L = 10\text{ pF}$	-	1.7 <sup>(2)</sup>	2 <sup>(2)</sup>	$\mu\text{s}$	
$t_{WAKEUP}^{(3)}$	Wakeup time from off state (setting the Enx bit in the DAC Control register) until the $\pm 1\text{LSB}$ final value	Normal mode, DAC output buffer ON, $C_L \leq 50\text{ pF}$ , $R_L = 5\text{ ?}$	-	5	7.5	$\mu\text{s}$	
$V_{offset}^{(2)}$	Middle code offset for 1 trim code step	$V_{REF+} = 3.6\text{ V}$	-	850	-	$\mu\text{V}$	
		$V_{REF+} = 1.8\text{ V}$	-	425	-		

**Table 87. DAC characteristics<sup>(1)</sup> (continued)**

Symbol	Parameter	Conditions		Min	Typ	Max	Unit
I <sub>DDA(DAC)</sub>	DAC quiescent consumption from V <sub>DDA</sub>	DAC output buffer ON	No load, middle code (0x800)	-	360	-	μA
			No load, worst code (0xF1C)	-	490	-	
		DAC output buffer OFF	No load, middle/worst code (0x800)	-	20	-	
		Sample and Hold mode, C <sub>SH</sub> =100 nF		-	360*T <sub>ON</sub> / (T <sub>ON</sub> +T <sub>OFF</sub> )	-	
I <sub>DDV(DAC)</sub>	DAC consumption from V <sub>REF+</sub>	DAC output buffer ON	No load, middle code (0x800)	-	170	-	
			No load, worst code (0xF1C)	-	170	-	
		DAC output buffer OFF	No load, middle/worst code (0x800)	-	160	-	
		Sample and Hold mode, Buffer ON, C <sub>SH</sub> =100 nF (worst code)		-	170*T <sub>ON</sub> / (T <sub>ON</sub> +T <sub>OFF</sub> )	-	
		Sample and Hold mode, Buffer OFF, C <sub>SH</sub> =100 nF (worst code)		-	160*T <sub>ON</sub> / (T <sub>ON</sub> +T <sub>OFF</sub> )	-	

1. Guaranteed by characterization results.
2. Guaranteed by design.
3. In buffered mode, the output can overshoot above the final value for low input code (starting from the minimum value).

**Table 88. DAC accuracy<sup>(1)</sup>**

Symbol	Parameter	Conditions		Min	Typ	Max	Unit
DNL	Differential non linearity <sup>(2)</sup>	DAC output buffer ON		-	±2	-	LSB
		DAC output buffer OFF		-	±2	-	
INL	Integral non linearity <sup>(3)</sup>	DAC output buffer ON, C <sub>L</sub> ≤ 50 pF, R <sub>L</sub> ≥ 5 ?		-	±4	-	LSB
		DAC output buffer OFF, C <sub>L</sub> ≤ 50 pF, no R <sub>L</sub>		-	±4	-	
Offset	Offset error at code 0x800 <sup>(3)</sup>	DAC output buffer ON, C <sub>L</sub> ≤ 50 pF, R <sub>L</sub> ≥ 5 ?	V <sub>REF+</sub> = 3.6 V	-	-	±12	LSB
			V <sub>REF+</sub> = 1.8 V	-	-	±25	
		DAC output buffer OFF, C <sub>L</sub> ≤ 50 pF, no R <sub>L</sub>		-	-	±8	

**Table 88. DAC accuracy<sup>(1)</sup> (continued)**

Symbol	Parameter	Conditions	Min	Typ	Max	Unit	
Offset1	Offset error at code 0x001 <sup>(4)</sup>	DAC output buffer OFF, $C_L \leq 50$ pF, no $R_L$	-	-	$\pm 5$	LSB	
OffsetCal	Offset error at code 0x800 after factory calibration	DAC output buffer ON, $C_L \leq 50$ pF, $R_L \geq 5 \text{ ?}$	$V_{REF+} = 3.6$ V	-	-	$\pm 5$	LSB
			$V_{REF+} = 1.8$ V	-	-	$\pm 7$	
Gain	Gain error <sup>(5)</sup>	DAC output buffer ON, $C_L \leq 50$ pF, $R_L \geq 5 \text{ ?}$	-	-	$\pm 1$	%	
		DAC output buffer OFF, $C_L \leq 50$ pF, no $R_L$	-	-	$\pm 1$		
TUE	Total unadjusted error	DAC output buffer OFF, $C_L \leq 50$ pF, no $R_L$	-	-	$\pm 12$	LSB	
SNR	Signal-to-noise ratio <sup>(6)</sup>	DAC output buffer ON, $C_L \leq 50$ pF, $R_L \geq 5 \text{ ?}$ , 1 kHz, BW = 500 KHz	-	67.8	-	dB	
SINAD	Signal-to-noise and distortion ratio <sup>(6)</sup>	DAC output buffer ON, $C_L \leq 50$ pF, $R_L \geq 5 \text{ ?}$ , 1 kHz	-	67.5	-	dB	
ENOB	Effective number of bits	DAC output buffer ON, $C_L \leq 50$ pF, $R_L \geq 5 \text{ ?}$ , 1 kHz	-	10.9	-	bits	

1. Guaranteed by characterization.
2. Difference between two consecutive codes minus 1 LSB.
3. Difference between the value measured at Code i and the value measured at Code i on a line drawn between Code 0 and last Code 4095.
4. Difference between the value measured at Code (0x001) and the ideal value.
5. Difference between the ideal slope of the transfer function and the measured slope computed from code 0x000 and 0xFFFF when the buffer is OFF, and from code giving 0.2 V and ( $V_{REF+} - 0.2$  V) when the buffer is ON.
6. Signal is -0.5dBFS with  $F_{sampling}=1$  MHz.

Figure 40. 12-bit buffered /non-buffered DAC

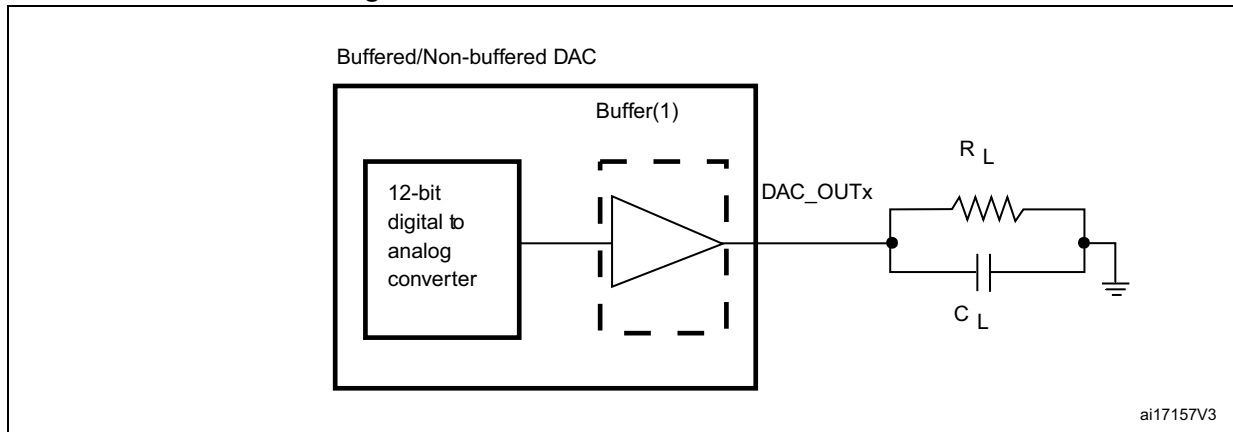

1. The DAC integrates an output buffer that can be used to reduce the output impedance and to drive external loads directly without the use of an external operational amplifier. The buffer can be bypassed by configuring the BOFFx bit in the DAC\_CR register.

### 6.3.22 Voltage reference buffer characteristics

Table 89. VREFBUF characteristics<sup>(1)</sup>

Symbol	Parameter	Conditions		Min	Typ	Max	Unit
V <sub>DDA</sub>	Analog supply voltage	Normal mode	VSCALE = 000	2.8	3.3	3.6	V
			VSCALE = 001	2.4	-	3.6	
			VSCALE = 010	2.1	-	3.6	
			VSCALE = 011	1.8	-	3.6	
		Degraded mode	VSCALE = 000	1.62	-	2.80	
			VSCALE = 001	1.62	-	2.40	
			VSCALE = 010	1.62	-	2.10	
			VSCALE = 011	1.62	-	1.80	
V <sub>REFBUF_OUT</sub>	Voltage Reference Buffer Output	Normal mode	VSCALE = 000	-	2.5	-	
			VSCALE = 001	-	2.048	-	
			VSCALE = 010	-	1.8	-	
			VSCALE = 011	-	1.5	-	
		Degraded mode <sup>(2)</sup>	VSCALE = 000	V <sub>DDA</sub> - 150 mV	-	V <sub>DDA</sub>	
			VSCALE = 001	V <sub>DDA</sub> - 150 mV	-	V <sub>DDA</sub>	
			VSCALE = 010	V <sub>DDA</sub> - 150 mV	-	V <sub>DDA</sub>	
			VSCALE = 011	V <sub>DDA</sub> - 150 mV	-	V <sub>DDA</sub>	
TRIM	Trim step resolution	-	-	-	±0.05	±0.2	%
C <sub>L</sub>	Load capacitor	-	-	0.5	1	1.50	uF



Table 89. VREFBUF characteristics<sup>(1)</sup> (continued)

Symbol	Parameter	Conditions		Min	Typ	Max	Unit
esr	Equivalent Serial Resistor of C <sub>L</sub>	-	-	-	-	2	?
I <sub>load</sub>	Static load current	-	-	-	-	4	mA
I <sub>line_reg</sub>	Line regulation	2.8 V ≤ V <sub>DDA</sub> ≤ 3.6 V	I <sub>load</sub> = 500 μA	-	200	-	ppm/V
			I <sub>load</sub> = 4 mA	-	100	-	
I <sub>load_reg</sub>	Load regulation	500 μA ≤ I <sub>LOAD</sub> ≤ 4 mA	Normal Mode	-	50	-	ppm/ mA
T <sub>coeff</sub>	Temperature coefficient	-40 °C < T <sub>J</sub> < +125 °C	-	-	-	T <sub>coeff</sub> xV <sub>REFINT</sub> + 75	ppm/ °C
PSRR	Power supply rejection	DC	-	-	60	-	dB
		100KHz	-	-	40	-	
t <sub>START</sub>	Start-up time	C <sub>L</sub> =0.5 μF	-	-	300	-	μs
		C <sub>L</sub> =1 μF	-	-	500	-	
		C <sub>L</sub> =1.5 μF	-	-	650	-	
I <sub>INRUSH</sub>	Control of maximum DC current drive on V <sub>REFBUF_OUT</sub> during startup phase <sup>(3)</sup>	-	-	-	8	-	mA
I <sub>DDA(VREFBUF)</sub>	VREFBUF consumption from V <sub>DDA</sub>	I <sub>LOAD</sub> = 0 μA	-	-	15	25	μA
		I <sub>LOAD</sub> = 500 μA	-	-	16	30	
		I <sub>LOAD</sub> = 4 mA	-	-	32	50	

1. Guaranteed by design.
2. In degraded mode, the voltage reference buffer cannot accurately maintain the output voltage (V<sub>DDA</sub>-drop voltage).
3. To properly control VREFBUF I<sub>INRUSH</sub> current during the startup phase and the change of scaling, V<sub>DDA</sub> voltage should be in the range of 1.8 V-3.6 V, 2.1 V-3.6 V, 2.4 V-3.6 V and 2.8 V-3.6 V for VSCALE = 011, 010, 001 and 000, respectively.

### 6.3.23 Temperature sensor characteristics

Table 90. Temperature sensor characteristics

Symbol	Parameter	Min	Typ	Max	Unit
T <sub>L</sub> <sup>(1)</sup>	V <sub>SENSE</sub> linearity with temperature	-	-	3	°C
Avg_Slope <sup>(2)</sup>	Average slope	-	2	-	mV/°C
V <sub>30</sub> <sup>(3)</sup>	Voltage at 30°C ± 5 °C	-	0.62	-	V
t <sub>start_run</sub> <sup>(1)</sup>	Startup time in Run mode (buffer startup)	-	-	25.2	μs
t <sub>S_temp</sub> <sup>(1)</sup>	ADC sampling time when reading the temperature	9	-	-	
I <sub>sens</sub> <sup>(1)</sup>	Sensor consumption	-	0.18	0.31	μA
I <sub>sensbuf</sub> <sup>(1)</sup>	Sensor buffer consumption	-	3.8	6.5	

1. Guaranteed by design.

2. Guaranteed by characterization.
3. Measured at  $V_{DDA} = 3.3 \text{ V} \pm 10 \text{ mV}$ . The  $V_{30}$  ADC conversion result is stored in the TS\_CAL1 byte.

**Table 91. Temperature sensor calibration values**

Symbol	Parameter	Memory address
TS_CAL1	Temperature sensor raw data acquired value at 30 °C, $V_{DDA}=3.3 \text{ V}$	0x1FF1 E820 - 0x1FF1 E821
TS_CAL2	Temperature sensor raw data acquired value at 110 °C, $V_{DDA}=3.3 \text{ V}$	0x1FF1 E840 - 0x1FF1 E841

### 6.3.24 Temperature and $V_{BAT}$ monitoring

**Table 92.  $V_{BAT}$  monitoring characteristics**

Symbol	Parameter	Min	Typ	Max	Unit
R	Resistor bridge for $V_{BAT}$	-	26	-	K $\Omega$
Q	Ratio on $V_{BAT}$ measurement	-	4	-	-
$E_r^{(1)}$	Error on Q	-10	-	+10	%
$t_{S\_vbat}^{(1)}$	ADC sampling time when reading $V_{BAT}$ input	9	-	-	$\mu\text{s}$
$V_{BAThigh}$	High supply monitoring	-	3.55	-	V
$V_{BATlow}$	Low supply monitoring	-	1.36	-	

1. Guaranteed by design.

**Table 93.  $V_{BAT}$  charging characteristics**

Symbol	Parameter	Condition	Min	Typ	Max	Unit
$R_{BC}$	Battery charging resistor	VBRS in PWR_CR3= 0	-	5	-	K $\Omega$
		VBRS in PWR_CR3= 1		1.5	-	

**Table 94. Temperature monitoring characteristics**

Symbol	Parameter	Min	Typ	Max	Unit
TEMP <sub>high</sub>	High temperature monitoring	-	117	-	°C
TEMP <sub>low</sub>	Low temperature monitoring	-	-25	-	

### 6.3.25 Voltage booster for analog switch

Table 95. Voltage booster for analog switch characteristics<sup>(1)</sup>

Symbol	Parameter	Condition	Min	Typ	Max	Unit
$V_{DD}$	Supply voltage	-	1.62	2-6	3.6	V
$t_{SU(BOOST)}$	Booster startup time	-	-	-	50	$\mu$ s
$I_{DD(BOOST)}$	Booster consumption	$1.62\text{ V} \leq V_{DD} \leq 2.7\text{ V}$	-	-	125	$\mu$ A
		$2.7\text{ V} < V_{DD} < 3.6\text{ V}$	-	-	250	

1. Guaranteed by characterization results.

## 6.3.26 Comparator characteristics

Table 96. COMP characteristics<sup>(1)</sup>

Symbol	Parameter	Conditions	Min	Typ	Max	Unit	
$V_{DDA}$	Analog supply voltage	-	1.62	3.3	3.6	V	
$V_{IN}$	Comparator input voltage range	-	0	-	$V_{DDA}$		
$V_{BG}^{(2)}$	Scaler input voltage	-	Refer to $V_{REFINT}$				
$V_{SC}$	Scaler offset voltage	-	-	±5	±10	mV	
$I_{DDA(SCALER)}$	Scaler static consumption from $V_{DDA}$	BRG_EN=0 (bridge disable)	-	0.2	0.3	µA	
		BRG_EN=1 (bridge enable)	-	0.8	1		
$t_{START\_SCALER}$	Scaler startup time	-	-	140	250	µs	
$t_{START}$	Comparator startup time to reach propagation delay specification	High-speed mode	-	2	5	µs	
		Medium mode	-	5	20		
		Ultra-low-power mode	-	15	80		
$t_D$	Propagation delay for 200 mV step with 100 mV overdrive	High-speed mode	-	50	80	ns	
		Medium mode	-	0.5	1.2	µs	
		Ultra-low-power mode	-	2.5	7		
	Propagation delay for step > 200 mV with 100 mV overdrive only on positive inputs	High-speed mode	-	50	120	ns	
		Medium mode	-	0.5	1.2	µs	
		Ultra-low-power mode	-	2.5	7		
$V_{offset}$	Comparator offset error	Full common mode range	-	±5	±20	mV	
$V_{hys}$	Comparator hysteresis	No hysteresis	-	0	-	mV	
		Low hysteresis	-	10	-		
		Medium hysteresis	-	20	-		
		High hysteresis	-	30	-		
$I_{DDA(COMP)}$	Comparator consumption from $V_{DDA}$	Ultra-low-power mode	Static	-	400	600	nA
			With 50 kHz ±100 mV overdrive square signal	-	800	-	
		Medium mode	Static	-	5	7	µA
			With 50 kHz ±100 mV overdrive square signal	-	6	-	
		High-speed mode	Static	-	70	100	
			With 50 kHz ±100 mV overdrive square signal	-	75	-	

1. Guaranteed by design, unless otherwise specified.

2. Refer to [Table 26: Embedded reference voltage](#).

## 6.3.27 Operational amplifier characteristics

Table 97. OPAMP characteristics<sup>(1)</sup>

Symbol	Parameter	Conditions	Min	Typ	Max	Unit
$V_{DDA}$	Analog supply voltage Range	-	2	3.3	3.6	V
CMIR	Common Mode Input Range	-	0	-	$V_{DDA}$	
$V_{I\text{OFFSET}}$	Input offset voltage	25°C, no load on output	-	-	$\pm 1.5$	mV
		All voltages and temperature, no load	-	-	$\pm 2.5$	
$\Delta V_{I\text{OFFSET}}$	Input offset voltage drift	-	-	$\pm 3.0$	-	$\mu\text{V}/^\circ\text{C}$
TRIMOFFSETP TRIMLPOFFSETP	Offset trim step at low common input voltage ( $0.1 \cdot V_{DDA}$ )	-	-	1.1	1.5	mV
TRIMOFFSETN TRIMLPOFFSETN	Offset trim step at high common input voltage ( $0.9 \cdot V_{DDA}$ )	-	-	1.1	1.5	
$I_{LOAD}$	Drive current	-	-	-	500	$\mu\text{A}$
$I_{LOAD\_PGA}$	Drive current in PGA mode	-	-	-	270	
$C_{LOAD}$	Capacitive load	-	-	-	50	pF
CMRR	Common mode rejection ratio	-	-	80	-	dB
PSRR	Power supply rejection ratio	$C_{LOAD} \leq 50\text{pf} /$ $R_{LOAD} \geq 4\text{k}\Omega^{(2)}$ at 1 kHz, $V_{com} = V_{DDA}/2$	50	66	-	dB
GBW	Gain bandwidth for high supply range	-	4	7.3	12.3	MHz
SR	Slew rate (from 10% and 90% of output voltage)	Normal mode	-	3	-	V/ $\mu\text{s}$
		High-speed mode	-	30	-	
AO	Open loop gain	-	59	90	129	dB
$\phi_m$	Phase margin	-	-	55	-	$^\circ$
GM	Gain margin	-	-	12	-	dB

Table 97. OPAMP characteristics<sup>(1)</sup> (continued)

Symbol	Parameter	Conditions	Min	Typ	Max	Unit
V <sub>OHSAT</sub>	High saturation voltage	I <sub>load</sub> =max or R <sub>LOAD</sub> =min <sup>(2)</sup> , Input at V <sub>DDA</sub>	V <sub>DDA</sub> -100 mV	-	-	mV
V <sub>OLSAT</sub>	Low saturation voltage	I <sub>load</sub> =max or R <sub>LOAD</sub> =min <sup>(2)</sup> , Input at 0 V	-	-	100	
t <sub>WAKEUP</sub>	Wake up time from OFF state	Normal mode C <sub>LOAD</sub> ≤ 50pf, R <sub>LOAD</sub> ≥ 4 kΩ <sup>(2)</sup> , follower configuration	-	0.8	3.2	μs
		High speed C <sub>LOAD</sub> ≤ 50pf, R <sub>LOAD</sub> ≥ 4 kΩ <sup>(2)</sup> , follower configuration	-	0.9	2.8	
PGA gain	Non inverting gain value	-	-	2	-	-
		-	-	4	-	-
		-	-	8	-	-
		-	-	16	-	-
	Inverting gain value	-	-	-1	-	-
		-	-	-3	-	-
		-	-	-7	-	-
-	-	-	-15	-	-	
R <sub>network</sub>	R2/R1 internal resistance values in non-inverting PGA mode <sup>(3)</sup>	PGA Gain=2	-	10/10	-	kΩ/ kΩ
		PGA Gain=4	-	30/10	-	
		PGA Gain=8	-	70/10	-	
		PGA Gain=16	-	150/10	-	
	R2/R1 internal resistance values in inverting PGA mode <sup>(3)</sup>	PGA Gain=-1	-	10/10	-	
		PGA Gain=-3	-	30/10	-	
		PGA Gain=-7	-	70/10	-	
		PGA Gain=-15	-	150/10	-	
Delta R	Resistance variation (R1 or R2)	-	-15	-	15	%
PGA BW	PGA bandwidth for different non inverting gain	Gain=2	-	GBW/2	-	MHz
		Gain=4	-	GBW/4	-	
		Gain=8	-	GBW/8	-	
		Gain=16	-	GBW/16	-	

Table 97. OPAMP characteristics<sup>(1)</sup> (continued)

Symbol	Parameter	Conditions		Min	Typ	Max	Unit
en	Voltage noise density	at 1 KHz	output loaded with 4 kΩ	-	140	-	nV/ $\sqrt{\text{Hz}}$
		at 10 KHz		-	55	-	
I <sub>DDA(OPAMP)</sub>	OPAMP consumption from V <sub>DDA</sub>	Normal mode	no Load, quiescent mode, follower	-	570	1000	μA
		High- speed mode		-	610	1200	

1. Guaranteed by design, unless otherwise specified.
2. R<sub>LOAD</sub> is the resistive load connected to VSSA or to VDDA.
3. R2 is the internal resistance between the OPAMP output and the OPAMP inverting input. R1 is the internal resistance between the OPAMP inverting input and ground. PGA gain = 1 + R2/R1.

### 6.3.28 Digital filter for Sigma-Delta Modulators (DFSDM) characteristics

Unless otherwise specified, the parameters given in [Table 98](#) for DFSDM are derived from tests performed under the ambient temperature,  $f_{PCLKx}$  frequency and  $V_{DD}$  supply voltage summarized in [Table 22: General operating conditions](#), with the following configuration:

- Output speed is set to  $OSPEEDRy[1:0] = 10$
- Capacitive load  $C = 30$  pF
- Measurement points are done at CMOS levels:  $0.5V_{DD}$

Refer to [Section 6.3.15: I/O port characteristics](#) for more details on the input/output alternate function characteristics (DFSDMx\_CKINx, DFSDMx\_DATINx, DFSDMx\_CKOUT for DFSDMx).

**Table 98. DFSDM measured timing - 1.62-3.6 V<sup>(1)</sup>**

Symbol	Parameter	Conditions	Min	Typ	Max	Unit
$f_{DFSDMCLK}$	DFSDM clock	$1.62\text{ V} < V_{DD} < 3.6\text{ V}$	-	-	250	
$f_{CKIN}$ ( $1/T_{CKIN}$ )	Input clock frequency	SPI mode (SITP[1:0]=0,1), External clock mode (SPICKSEL[1:0]=0), $1.62\text{ V} < V_{DD} < 3.6\text{ V}$	-	-	20 ( $f_{DFSDMCLK}/4$ )	MHz
		SPI mode (SITP[1:0]=0,1), External clock mode (SPICKSEL[1:0]=0), $2.7 < V_{DD} < 3.6\text{ V}$	-	-	20 ( $f_{DFSDMCLK}/4$ )	
		SPI mode (SITP[1:0]=0,1), Internal clock mode (SPICKSEL[1:0]≠0), $1.62 < V_{DD} < 3.6\text{ V}$	-	-	20 ( $f_{DFSDMCLK}/4$ )	
		SPI mode (SITP[1:0]=0,1), Internal clock mode (SPICKSEL[1:0]≠0), $2.7 < V_{DD} < 3.6\text{ V}$	-	-	20 ( $f_{DFSDMCLK}/4$ )	
$f_{CKOUT}$	Output clock frequency	$1.62 < V_{DD} < 3.6\text{ V}$	-	-	20	
DuCy <sub>CKOUT</sub>	Output clock frequency duty cycle	$1.62 < V_{DD} < 3.6\text{ V}$	45	50	55	%

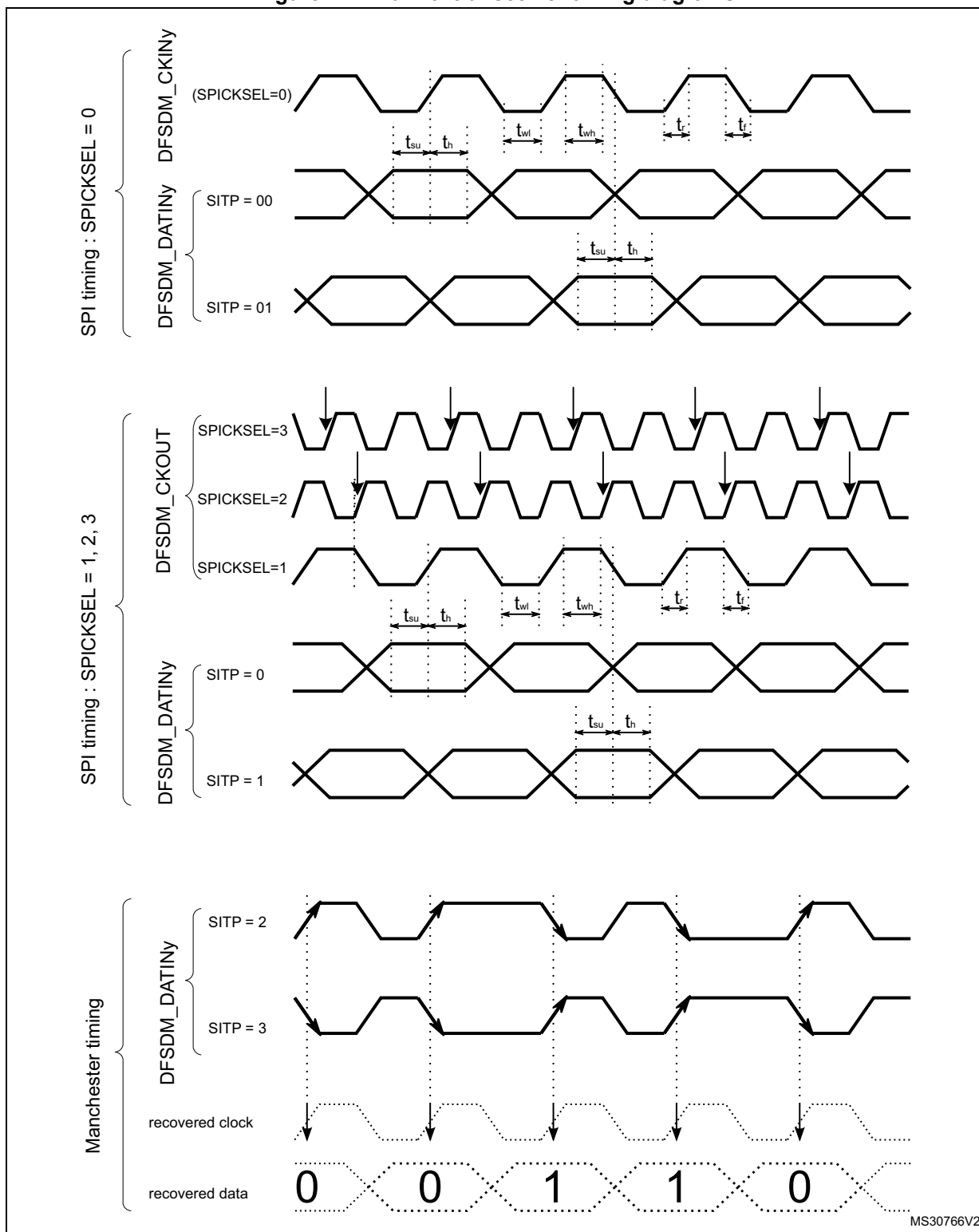

**Table 98. DFSDM measured timing - 1.62-3.6 V<sup>(1)</sup> (continued)**

Symbol	Parameter	Conditions	Min	Typ	Max	Unit
$t_{wh(CKIN)}$ $t_{wl(CKIN)}$	Input clock high and low time	SPI mode (SITP[1:0]=0,1), External clock mode (SPICKSEL[1:0]=0), 1.62 < V <sub>DD</sub> < 3.6 V	$T_{CKIN}/2 - 0.5$	$T_{CKIN}/2$	-	ns
$t_{su}$	Data input setup time	SPI mode (SITP[1:0]=0,1), External clock mode (SPICKSEL[1:0]=0), 1.62 < V <sub>DD</sub> < 3.6 V	4	-	-	
$t_h$	Data input hold time	SPI mode (SITP[1:0]=0,1), External clock mode (SPICKSEL[1:0]=0), 1.62 < V <sub>DD</sub> < 3.6 V	0.5	-	-	
$T_{Manchester}$	Manchester data period (recovered clock period)	Manchester mode (SITP[1:0]=2,3), Internal clock mode (SPICKSEL[1:0]≠0), 1.62 < V <sub>DD</sub> < 3.6 V	$(CKOUTDIV+1) * T_{DFSDMCLK}$	-	$(2*CKOUTDIV) * T_{DFSDMCLK}$	

1. Guaranteed by characterization results.

Figure 41. Channel transceiver timing diagrams



### 6.3.29 Camera interface (DCMI) timing specifications

Unless otherwise specified, the parameters given in [Table 99](#) for DCMI are derived from tests performed under the ambient temperature,  $f_{rcc\_c\_ck}$  frequency and  $V_{DD}$  supply voltage summarized in [Table 22: General operating conditions](#), with the following configuration:

- DCMI\_PIXCLK polarity: falling
- DCMI\_VSYNC and DCMI\_HSYNC polarity: high
- Data formats: 14 bits
- Capacitive load  $C=30$  pF
- Measurement points are done at CMOS levels:  $0.5V_{DD}$

**Table 99. DCMI characteristics<sup>(1)</sup>**

Symbol	Parameter	Min	Max	Unit
-	Frequency ratio DCMI_PIXCLK/ $f_{rcc\_c\_ck}$	-	0.4	-
DCMI_PIXCLK	Pixel clock input	-	80	MHz
$D_{Pixel}$	Pixel clock input duty cycle	30	70	%
$t_{su}(DATA)$	Data input setup time	1	-	ns
$t_h(DATA)$	Data input hold time	1	-	
$t_{su}(HSYNC)$ $t_{su}(VSYNC)$	DCMI_HSYNC/DCMI_VSYNC input setup time	1.5	-	
$t_h(HSYNC)$ $t_h(VSYNC)$	DCMI_HSYNC/DCMI_VSYNC input hold time	1	-	

1. Guaranteed by characterization results.

**Figure 42. DCMI timing diagram**

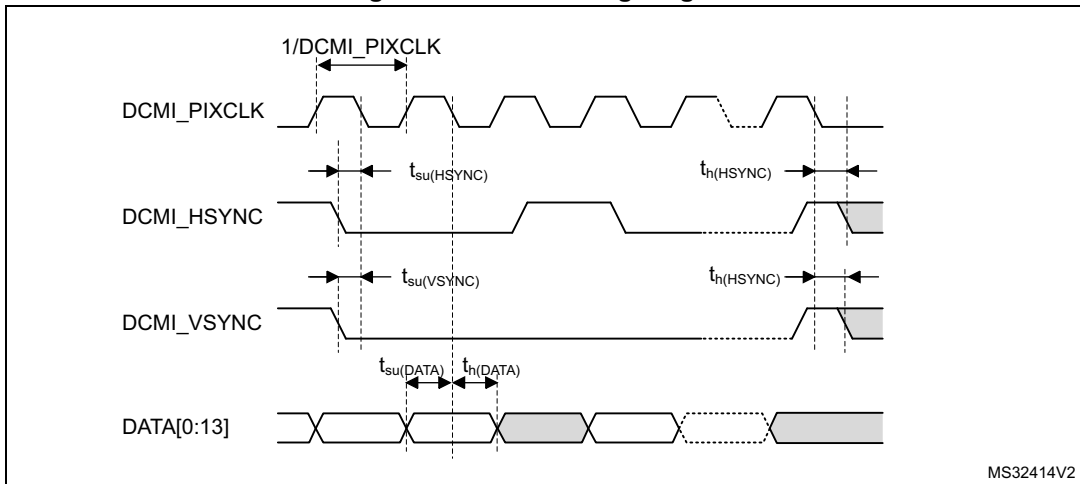

MS32414V2

### 6.3.30 LCD-TFT controller (LTDC) characteristics

Unless otherwise specified, the parameters given in [Table 100](#) for LCD-TFT are derived from tests performed under the ambient temperature,  $f_{\text{rcc\_c\_ck}}$  frequency and  $V_{\text{DD}}$  supply voltage summarized in [Table 22: General operating conditions](#), with the following configuration:

- LCD\_CLK polarity: high
- LCD\_DE polarity: low
- LCD\_VSYNC and LCD\_HSYNC polarity: high
- Pixel formats: 24 bits
- Output speed is set to OSPEEDRy[1:0] = 11
- Capacitive load C=30 pF
- Measurement points are done at CMOS levels:  $0.5V_{\text{DD}}$
- I/O compensation cell enabled

**Table 100. LTDC characteristics <sup>(1)</sup>**

Symbol	Parameter	Conditions	Min	Max	Unit
$f_{\text{CLK}}$	LTDC clock output frequency	$2.7 \text{ V} < V_{\text{DD}} < 3.6 \text{ V}$ , 20 pF	-	150	MHz
		$2.7 \text{ V} < V_{\text{DD}} < 3.6 \text{ V}$	-	133	
		$1.62 \text{ V} < V_{\text{DD}} < 3.6 \text{ V}$	-	90	
$D_{\text{CLK}}$	LTDC clock output duty cycle	-	45	55	%
$t_{\text{w}}(\text{CLKH})$ , $t_{\text{w}}(\text{CLKL})$	Clock High time, low time		$t_{\text{w}}(\text{CLK})/2-0.5$	$t_{\text{w}}(\text{CLK})/2+0.5$	ns
$t_{\text{v}}(\text{DATA})$	Data output valid time		-	0.5	
$t_{\text{h}}(\text{DATA})$	Data output hold time		0	-	
$t_{\text{v}}(\text{HSYNC})$ , $t_{\text{v}}(\text{VSYNC})$ , $t_{\text{v}}(\text{DE})$	HSYNC/VSYNC/DE output valid time		-	0.5	
$t_{\text{h}}(\text{HSYNC})$ , $t_{\text{h}}(\text{VSYNC})$ , $t_{\text{h}}(\text{DE})$	HSYNC/VSYNC/DE output hold time		0.5	-	

1. Guaranteed by characterization results.

Figure 43. LCD-TFT horizontal timing diagram

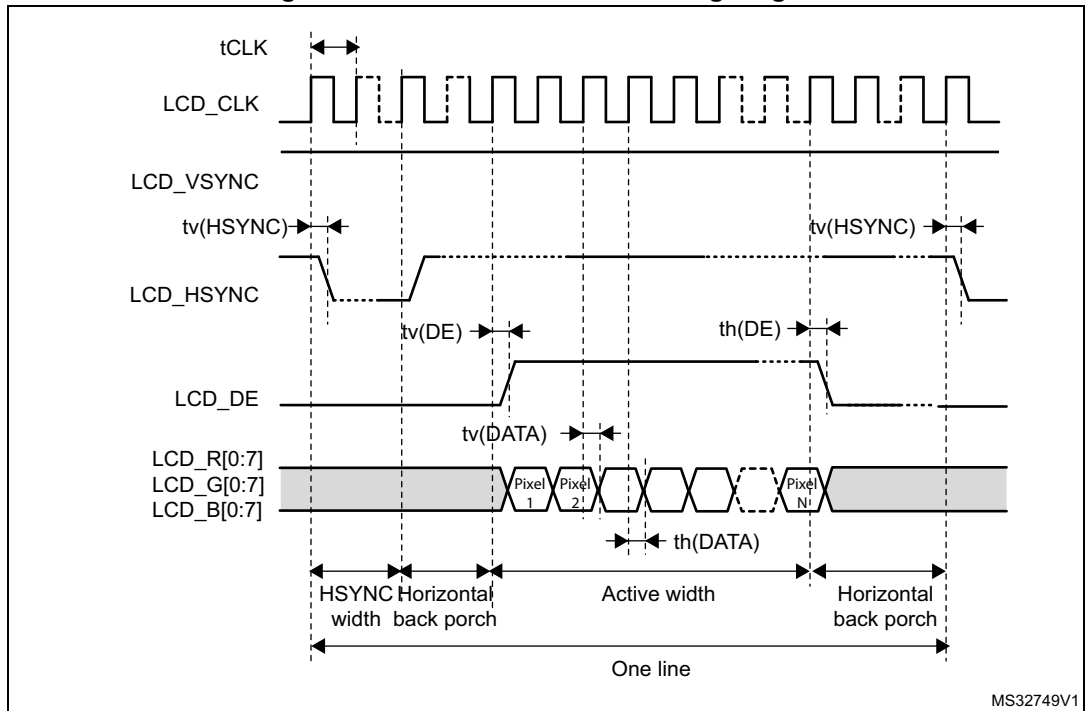
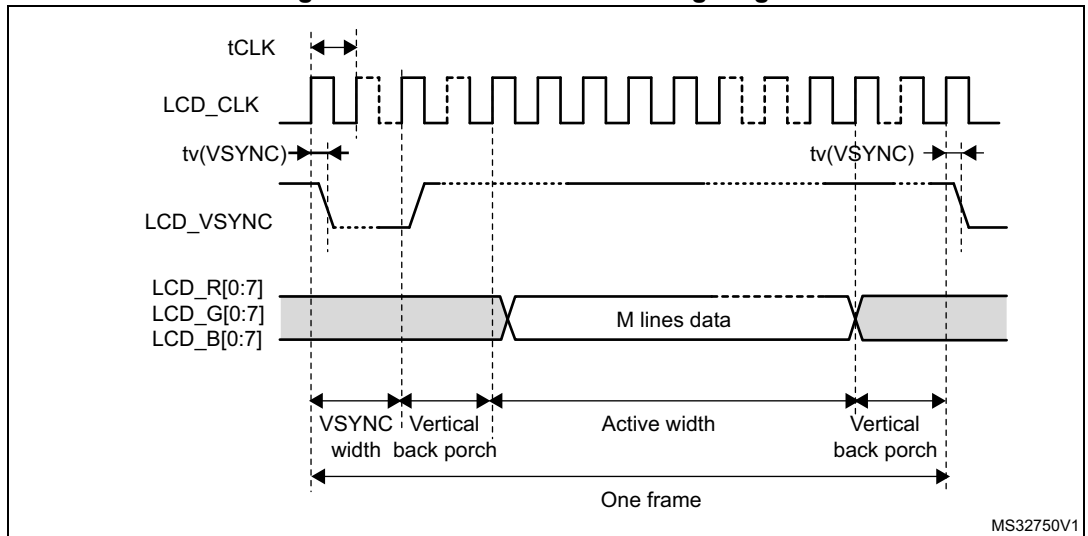

Figure 44. LCD-TFT vertical timing diagram



### 6.3.31 Timer characteristics

The parameters given in [Table 101](#) are guaranteed by design.

Refer to [Section 6.3.15: I/O port characteristics](#) for details on the input/output alternate function characteristics (output compare, input capture, external clock, PWM output).

**Table 101. TIMx characteristics<sup>(1)(2)</sup>**

Symbol	Parameter	Conditions <sup>(3)</sup>	Min	Max	Unit
$t_{res(TIM)}$	Timer resolution time	AHB/APBx prescaler=1 or 2 or 4, $f_{TIMxCLK} = 200$ MHz	1	-	$t_{TIMxCLK}$
		AHB/APBx prescaler>4, $f_{TIMxCLK} = 100$ MHz	1	-	$t_{TIMxCLK}$
$f_{EXT}$	Timer external clock frequency on CH1 to CH4	$f_{TIMxCLK} = 200$ MHz	0	$f_{TIMxCLK}/2$	MHz
$Res_{TIM}$	Timer resolution		-	16/32	bit
$t_{MAX\_COUNT}$	Maximum possible count with 32-bit counter	-	-	$65536 \times 65536$	$t_{TIMxCLK}$

1. TIMx is used as a general term to refer to the TIM1 to TIM17 timers.
2. Guaranteed by design.
3. The maximum timer frequency on APB1 or APB2 is up to 200 MHz, by setting the TIMPRE bit in the RCC\_CFGR register, if APBx prescaler is 1 or 2 or 4, then  $TIMxCLK = rcc_hclk1$ , otherwise  $TIMxCLK = 4 \times F_{rcc\_pclkx\_d2}$ .

### 6.3.32 Communications interfaces

#### I<sup>2</sup>C interface characteristics

The I<sup>2</sup>C interface meets the timings requirements of the I<sup>2</sup>C-bus specification and user manual revision 03 for:

- Standard-mode (Sm): with a bit rate up to 100 kbit/s
- Fast-mode (Fm): with a bit rate up to 400 kbit/s.
- Fast-mode Plus (Fm+): with a bit rate up to 1Mbit/s.

The I<sup>2</sup>C timings requirements are guaranteed by design when the I2C peripheral is properly configured (refer to RM0433 reference manual) and when the i2c\_ker\_ck frequency is greater than the minimum shown in the table below:

**Table 102. Minimum i2c\_ker\_ck frequency in all I<sup>2</sup>C modes**

Symbol	Parameter	Condition		Min	Unit
f(I2CCLK)	I2CCLK frequency	Standard-mode		2	MHz
		Fast-mode	Analog filter ON DNF=0	8	
			Analog filter OFF DNF=1	9	
		Fast-mode Plus	Analog filter ON DNF=0	17	
			Analog filter OFF DNF=1	16	

The SDA and SCL I/O requirements are met with the following restrictions:

- The SDA and SCL I/O pins are not “true” open-drain. When configured as open-drain, the PMOS connected between the I/O pin and V<sub>DD</sub> is disabled, but still present.
- The 20 mA output drive requirement in Fast-mode Plus is not supported. This limits the maximum load C<sub>load</sub> supported in Fm+, which is given by these formulas:

$$t_{r(SDA/SCL)} = 0.8473 \times R_p \times C_{load}$$

$$R_{p(min)} = (V_{DD} - V_{OL(max)}) / I_{OL(max)}$$

Where R<sub>p</sub> is the I2C lines pull-up. Refer to [Section 6.3.15: I/O port characteristics](#) for the I2C I/Os characteristics.

All I<sup>2</sup>C SDA and SCL I/Os embed an analog filter. Refer to [Table 103](#) for the analog filter characteristics:

**Table 103. I2C analog filter characteristics<sup>(1)</sup>**

Symbol	Parameter	Min	Max	Unit
t <sub>AF</sub>	Maximum pulse width of spikes that are suppressed by the analog filter	50 <sup>(2)</sup>	260 <sup>(3)</sup>	ns

1. Guaranteed by design.
2. Spikes with widths below t<sub>AF(min)</sub> are filtered.
3. Spikes with widths above t<sub>AF(max)</sub> are not filtered.

**SPI interface characteristics**

Unless otherwise specified, the parameters given in [Table 104](#) for the SPI interface are derived from tests performed under the ambient temperature,  $f_{PCLKx}$  frequency and  $V_{DD}$  supply voltage conditions summarized in [Table 22: General operating conditions](#), with the following configuration:

- Output speed is set to  $OSPEEDRy[1:0] = 11$
- Capacitive load  $C = 30 \text{ pF}$
- Measurement points are done at CMOS levels:  $0.5V_{DD}$
- I/O compensation cell enabled
- HSLV activated when  $V_{DD} \leq 2.7 \text{ V}$

Refer to [Section 6.3.15: I/O port characteristics](#) for more details on the input/output alternate function characteristics (NSS, SCK, MOSI, MISO for SPI).

**Table 104. SPI dynamic characteristics<sup>(1)</sup>**

Symbol	Parameter	Conditions	Min	Typ	Max	Unit
$f_{SCK}$ $1/t_{c(SCK)}$	SPI clock frequency	Master mode $1.62 \text{ V} \leq V_{DD} \leq 3.6 \text{ V}$	-	-	90	MHz
		Master mode $2.7 \text{ V} \leq V_{DD} \leq 3.6 \text{ V}$ SPI1,2,3			133	
		Master mode $2.7 \text{ V} \leq V_{DD} \leq 3.6 \text{ V}$ SPI4,5,6			100	
		Slave receiver mode $1.62 \text{ V} \leq V_{DD} \leq 3.6 \text{ V}$ SPI1,2,3			150	
		Slave receiver mode $1.62 \text{ V} \leq V_{DD} \leq 3.6 \text{ V}$ SPI4,5,6			100	
		Slave mode transmitter/full duplex $2.7 \text{ V} \leq V_{DD} \leq 3.6 \text{ V}$			31	
		Slave mode transmitter/full duplex $1.62 \text{ V} \leq V_{DD} \leq 3.6 \text{ V}$			25	
$t_{su(NSS)}$	NSS setup time	Slave mode	2	-	-	ns
$t_h(NSS)$	NSS hold time		1	-	-	
$t_w(SCKH)$ , $t_w(SCKL)$	SCK high and low time	Master mode	$T_{PLCK} - 2$	$T_{PLCK}$	$T_{PLCK} + 2$	

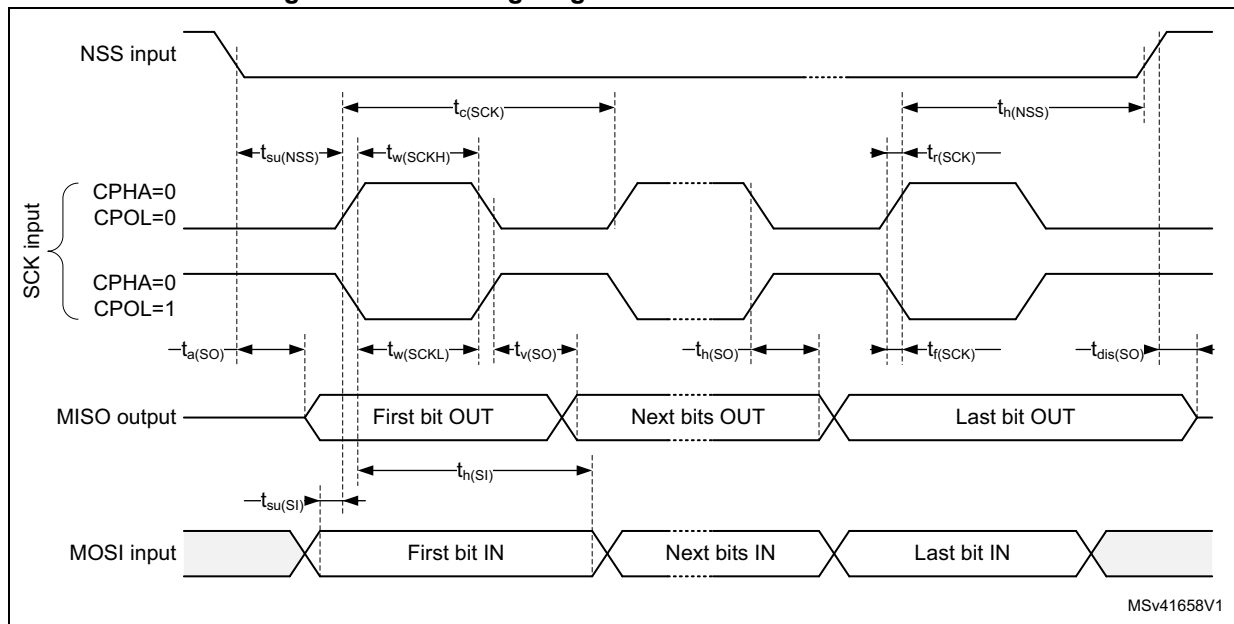

Table 104. SPI dynamic characteristics<sup>(1)</sup> (continued)

Symbol	Parameter	Conditions	Min	Typ	Max	Unit
$t_{su(MI)}$	Data input setup time	Master mode	1	-	-	ns
$t_{su(SI)}$		Slave mode	2	-	-	
$t_{h(MI)}$	Data input hold time	Master mode	2	-	-	
$t_{h(SI)}$		Slave mode	1	-	-	
$t_{a(SO)}$	Data output access time	Slave mode	9	13	27	
$t_{dis(SO)}$	Data output disable time	Slave mode	0	1	5	
$t_{V(SO)}$	Data output valid time	Slave mode, $2.7 V \leq V_{DD} \leq 3.6 V$	-	11.5	16	
		Slave mode $1.62 V \leq V_{DD} \leq 3.6 V$	-	13	20	
$t_{V(MO)}$		Master mode	-	1	3	
$t_{h(SO)}$	Data output hold time	Slave mode, $1.62 V \leq V_{DD} \leq 3.6 V$	9	-	-	
$t_{h(MO)}$		Master mode	0	-	-	

1. Guaranteed by characterization results.

Figure 45. SPI timing diagram - slave mode and CPHA = 0



MSv41658V1

Figure 46. SPI timing diagram - slave mode and CPHA = 1<sup>(1)</sup>

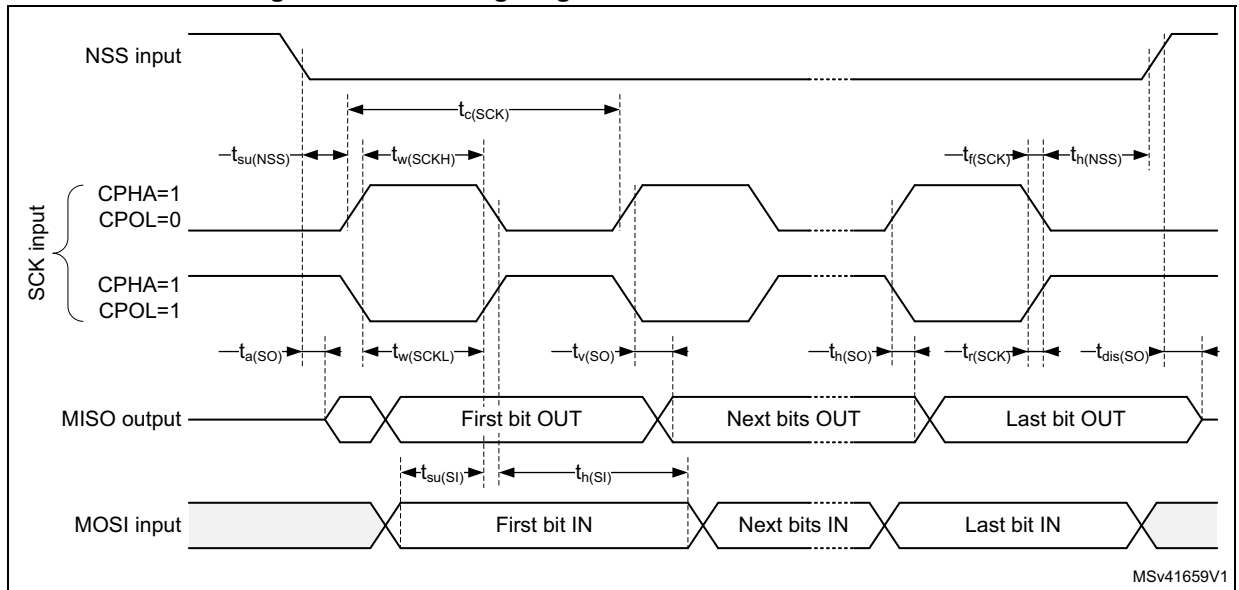

1. Measurement points are done at 0.5V<sub>DD</sub> and with external C<sub>L</sub> = 30 pF.

Figure 47. SPI timing diagram - master mode<sup>(1)</sup>

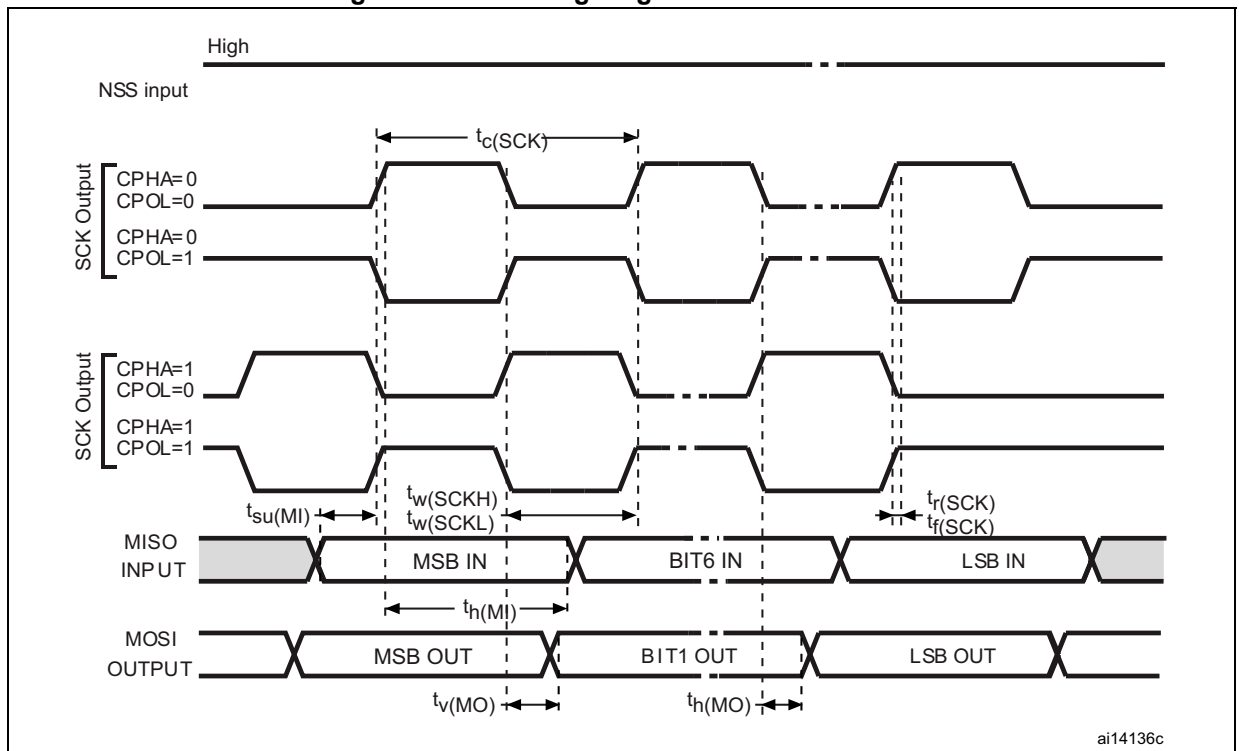

1. Measurement points are done at 0.5V<sub>DD</sub> and with external C<sub>L</sub> = 30 pF.

## I<sup>2</sup>S interface characteristics

Unless otherwise specified, the parameters given in [Table 105](#) for the I<sup>2</sup>S interface are derived from tests performed under the ambient temperature,  $f_{PCLKx}$  frequency and  $V_{DD}$  supply voltage conditions summarized in [Table 22: General operating conditions](#), with the following configuration:

- Output speed is set to  $OSPEEDRy[1:0] = 10$
- Capacitive load  $C = 30$  pF
- Measurement points are done at CMOS levels:  $0.5V_{DD}$
- I/O compensation cell enabled

Refer to [Section 6.3.15: I/O port characteristics](#) for more details on the input/output alternate function characteristics (CK, SD, WS).

**Table 105. I<sup>2</sup>S dynamic characteristics<sup>(1)</sup>**

Symbol	Parameter	Conditions	Min	Max	Unit
$f_{MCK}$	I2S Main clock output	-	256x8K	$256F_S$	MHz
$f_{CK}$	I2S clock frequency	Master data	-	$64F_S$	MHz
		Slave data	-	$64F_S$	
$t_{v(WS)}$	WS valid time	Master mode	-	3.5	ns
$t_{h(WS)}$	WS hold time	Master mode	0	-	
$t_{su(WS)}$	WS setup time	Slave mode	1	-	
$t_{h(WS)}$	WS hold time	Slave mode	1	-	
$t_{su(SD\_MR)}$	Data input setup time	Master receiver	1	-	
$t_{su(SD\_SR)}$		Slave receiver	1	-	
$t_{h(SD\_MR)}$	Data input hold time	Master receiver	4	-	
$t_{h(SD\_SR)}$		Slave receiver	2	-	
$t_{v(SD\_ST)}$	Data output valid time	Slave transmitter (after enable edge)	-	20	
$t_{v(SD\_MT)}$		Master transmitter (after enable edge)	-	3	
$t_{h(SD\_ST)}$	Data output hold time	Slave transmitter (after enable edge)	9	-	
$t_{h(SD\_MT)}$		Master transmitter (after enable edge)	0	-	

1. Guaranteed by characterization results.

Figure 48. I<sup>2</sup>S slave timing diagram (Philips protocol)<sup>(1)</sup>

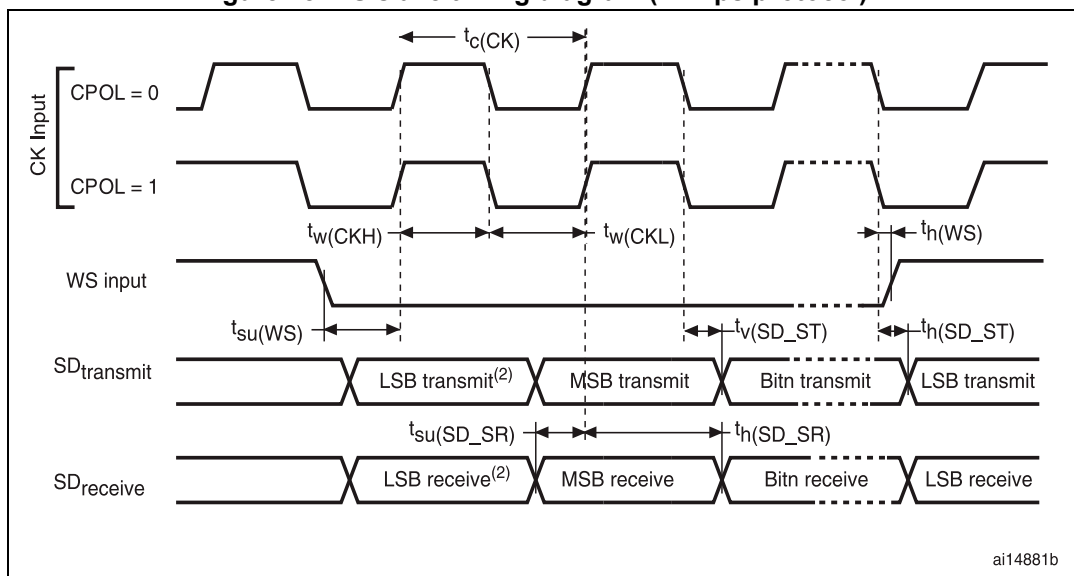

1. LSB transmit/receive of the previously transmitted byte. No LSB transmit/receive is sent before the first byte.

Figure 49. I<sup>2</sup>S master timing diagram (Philips protocol)<sup>(1)</sup>

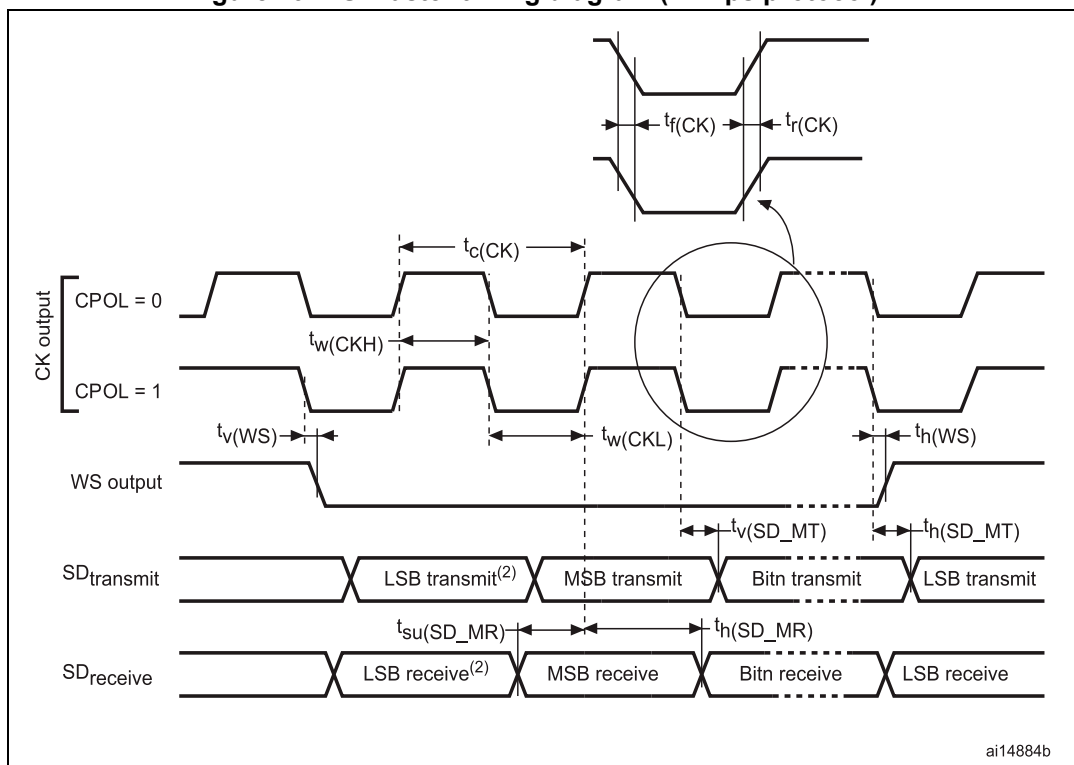

1. LSB transmit/receive of the previously transmitted byte. No LSB transmit/receive is sent before the first byte.

### SAI characteristics

Unless otherwise specified, the parameters given in [Table 106](#) for SAI are derived from tests performed under the ambient temperature,  $f_{PCLKx}$  frequency and VDD supply voltage conditions summarized in [Table 22: General operating conditions](#), with the following configuration:

- Output speed is set to OSPEEDRy[1:0] = 10
- Capacitive load C=30 pF
- Measurement points are performed at CMOS levels:  $0.5V_{DD}$

Refer to [Section 6.3.15: I/O port characteristics](#) for more details on the input/output alternate function characteristics (SCK,SD,WS).

**Table 106. SAI characteristics<sup>(1)</sup>**

Symbol	Parameter	Conditions	Min	Max	Unit
$f_{MCK}$	SAI Main clock output	-	256 x 8K	256xFs	MHz
$F_{CK}$	SAI clock frequency <sup>(2)</sup>	Master data: 32 bits	-	128xFs <sup>(3)</sup>	MHz
		Slave data: 32 bits	-	128xFs	
$t_{v(FS)}$	FS valid time	Master mode $2.7 \leq V_{DD} \leq 3.6V$	-	15	ns
		Master mode $1.71 \leq V_{DD} \leq 3.6V$	-	20	
$t_{su(FS)}$	FS setup time	Slave mode	7	-	
$t_{h(FS)}$	FS hold time	Master mode	1	-	
		Slave mode	1	-	
$t_{su(SD\_A\_MR)}$	Data input setup time	Master receiver	0.5	-	
$t_{su(SD\_B\_SR)}$		Slave receiver	1	-	
$t_{h(SD\_A\_MR)}$	Data input hold time	Master receiver	3.5	-	
$t_{h(SD\_B\_SR)}$		Slave receiver	2	-	
$t_{v(SD\_B\_ST)}$	Data output valid time	Slave transmitter (after enable edge) $2.7 \leq V_{DD} \leq 3.6V$	-	17	
		Slave transmitter (after enable edge) $1.62 \leq V_{DD} \leq 3.6V$	-	20	
$t_{h(SD\_B\_ST)}$	Data output hold time	Slave transmitter (after enable edge)	7	-	
$t_{v(SD\_A\_MT)}$	Data output valid time	Master transmitter (after enable edge) $2.7 \leq V_{DD} \leq 3.6V$	-	17	
		Master transmitter (after enable edge) $1.62 \leq V_{DD} \leq 3.6V$	-	20	
$t_{h(SD\_A\_MT)}$	Data output hold time	Master transmitter (after enable edge)	7.55	-	

1. Guaranteed by characterization results.
2. APB clock frequency must be at least twice SAI clock frequency.
3. With  $F_S=192$  kHz.

Figure 50. SAI master timing waveforms

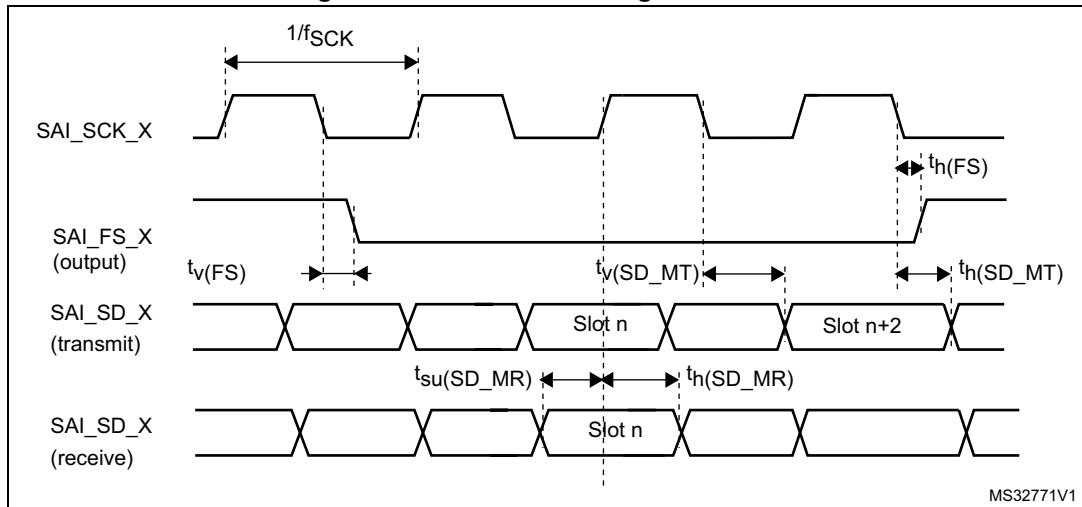

MS32771V1

Figure 51. SAI slave timing waveforms

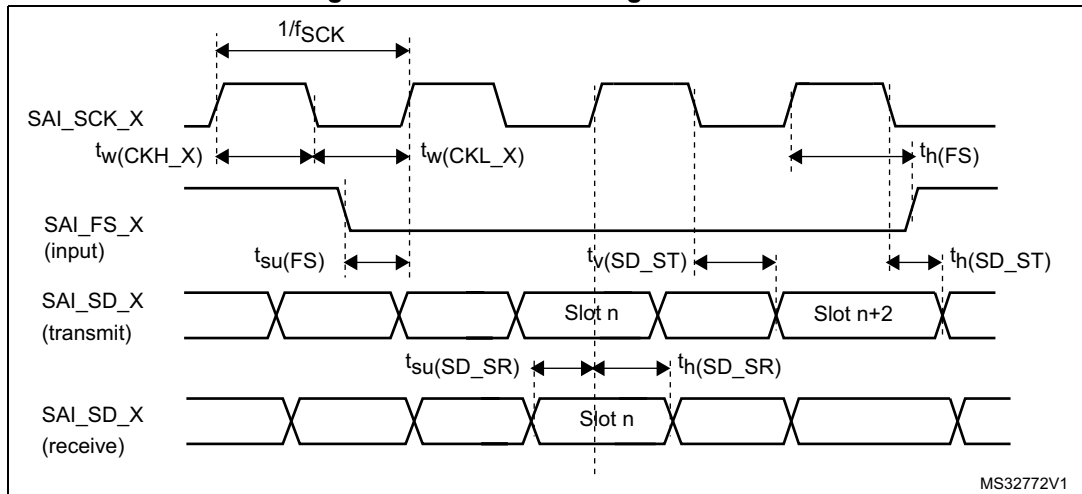

MS32772V1

MDIO characteristics

Table 107. MDIO Slave timing parameters

Symbol	Parameter	Min	Typ	Max	Unit
$F_{sDC}$	Management data clock	-	-	40	MHz
$t_d(MDIO)$	Management data input/output <b>output valid time</b>	7	8	20	ns
$t_{su}(MDIO)$	Management data input/output <b>setup time</b>	4	-	-	
$t_h(MDIO)$	Management data input/output <b>hold time</b>	1	-	-	

The MDIO controller is mapped on APB2 domain. The frequency of the APB bus should at least 1.5 times the MDC frequency:  $F_{PCLK2} \geq 1.5 * F_{MDC}$ .

Figure 52. MDIO Slave timing diagram

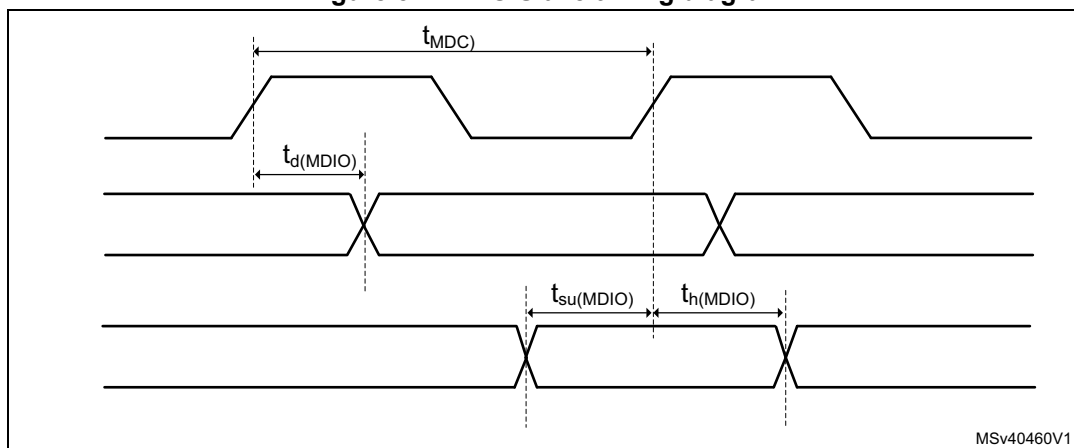

MSv40460V1

**SD/SDIO MMC card host interface (SDMMC) characteristics**

Unless otherwise specified, the parameters given in [Table 108](#) for the SDIO/MMC interface are derived from tests performed under the ambient temperature,  $f_{PCLK2}$  frequency and  $V_{DD}$  supply voltage conditions summarized in [Table 22: General operating conditions](#), with the following configuration:

- Output speed is set to OSPEEDRy[1:0] = 11
- Capacitive load C = 30 pF
- Measurement points are done at CMOS levels:  $0.5V_{DD}$
- I/O compensation cell enabled
- HSLV activated when  $V_{DD} \leq 2.7 V$

Refer to [Section 6.3.15: I/O port characteristics](#) for more details on the input/output characteristics.

**Table 108. Dynamic characteristics: SD / MMC characteristics,  $V_{DD}=2.7V$  to  $3.6V^{(1)(2)}$**

Symbol	Parameter	Conditions	Min	Typ	Max	Unit
$f_{PP}$	Clock frequency in data transfer mode	-	0	-	125	MHz
$t_{W(CKL)}$	Clock low time	$f_{PP} = 50 \text{ MHz}$	9.5	10.5	-	ns
$t_{W(CKH)}$	Clock high time		8.5	9.5	-	
<b>CMD, D inputs (referenced to CK) in MMC and SD HS/SDR/DDR mode</b>						
$t_{ISU}$	Input setup time HS	$f_{PP} \geq 50 \text{ MHz}$	2	-	-	ns
$t_{IH}$	Input hold time HS		1.5	-	-	
$t_{IDW}^{(3)}$	Input valid window (variable window)		3	-	-	
<b>CMD, D outputs (referenced to CK) in MMC and SD HS/SDR/DDR mode</b>						
$t_{OV}$	Output valid time HS	$f_{PP} \geq 50 \text{ MHz}$	-	3.5	5	ns
$t_{OH}$	Output hold time HS		2	-	-	

Table 108. Dynamic characteristics: SD / MMC characteristics,  $V_{DD}=2.7V$  to  $3.6V^{(1)(2)}$ 

Symbol	Parameter	Conditions	Min	Typ	Max	Unit
<b>CMD, D inputs (referenced to CK) in SD default mode</b>						
$t_{ISUD}$	Input setup time SD	$f_{PP} = 25$ MHz	2	-	-	ns
$t_{IHD}$	Input hold time SD		1.5	-	-	
<b>CMD, D outputs (referenced to CK) in SD default mode</b>						
$t_{OVD}$	Output valid default time SD	$f_{PP} = 25$ MHz	-	1	2	ns
$t_{OHD}$	Output hold default time SD		0	-	-	

1. Guaranteed by characterization results.
2. Above 100 MHz,  $C_L = 20$  pF.
3. The minimum window of time where the data needs to be stable for proper sampling in tuning mode.

Table 109. Dynamic characteristics: eMMC characteristics,  $V_{DD}=1.71V$  to  $1.9V^{(1)(2)}$ 

Symbol	Parameter	Conditions	Min	Typ	Max	Unit
$f_{PP}$	Clock frequency in data transfer mode	-	0	-	120	MHz
$t_{W(CKL)}$	Clock low time	$f_{PP} = 50$ MHz	9.5	10.5	-	ns
$t_{W(CKH)}$	Clock high time		8.5	9.5	-	
<b>CMD, D inputs (referenced to CK) in eMMC mode</b>						
$t_{ISU}$	Input setup time HS	$f_{PP} \geq 50$ MHz	1.5	-	-	ns
$t_{IH}$	Input hold time HS		2	-	-	
$t_{IDW}^{(3)}$	Input valid window (variable window)		3.5	-	-	
<b>CMD, D outputs (referenced to CK) in eMMC mode</b>						
$t_{OV}$	Output valid time HS	$f_{PP} \geq 50$ MHz	-	5	7	ns
$t_{OH}$	Output hold time HS		3	-	-	

1. Guaranteed by characterization results.
2.  $C_L = 20$  pF.
3. The minimum window of time where the data needs to be stable for proper sampling in tuning mode.



Figure 53. SDIO high-speed mode

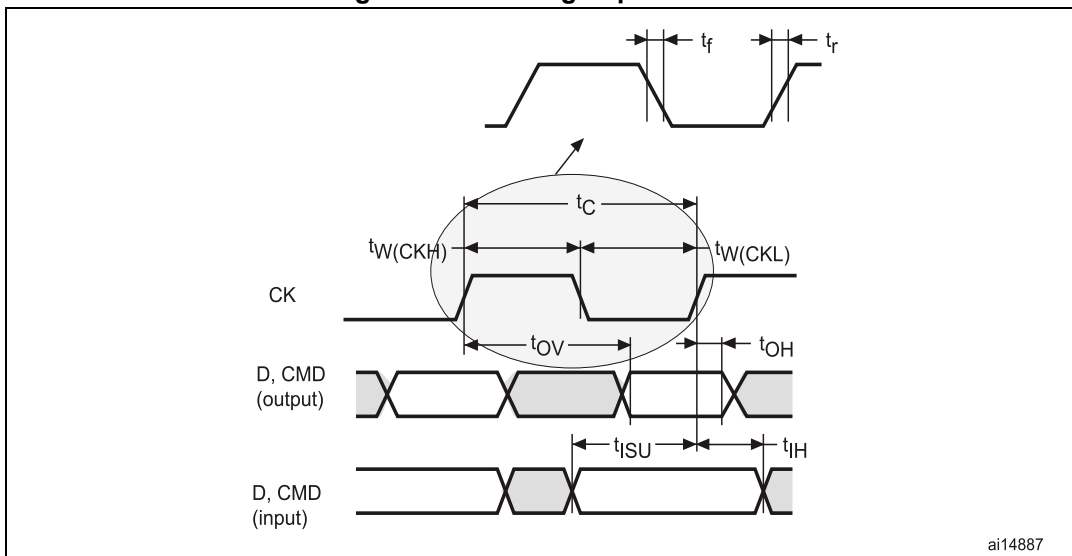

Figure 54. SD default mode

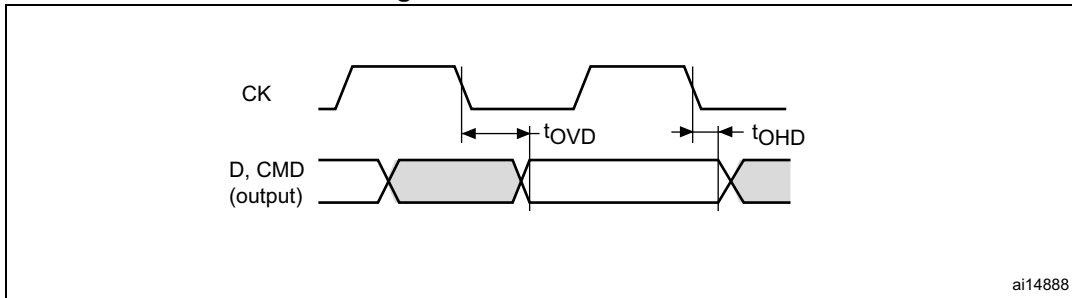

Figure 55. DDR mode



**CAN (controller area network) interface**

Refer to [Section 6.3.15: I/O port characteristics](#) for more details on the input/output alternate function characteristics (FDCANx\_TX and FDCANx\_RX).

### USB OTG\_FS characteristics

The USB interface is fully compliant with the USB specification version 2.0 and is USB-IF certified (for Full-speed device operation).

**Table 110. USB OTG\_FS electrical characteristics**

Symbol	Parameter	Condition	Min	Typ	Max	Unit
$V_{DD33USB}$	USB transceiver operating voltage	-	3.0 <sup>(1)</sup>	-	3.6	V
$R_{PUI}$	Embedded USB_DP pull-up value during idle	-	900	1250	1600	Ω
$R_{PUR}$	Embedded USB_DP pull-up value during reception	-	1400	2300	3200	
$Z_{DRV}$	Output driver impedance <sup>(2)</sup>	Driver high and low	28	36	44	

- The USB functionality is ensured down to 2.7 V but not the full USB electrical characteristics which are degraded in the 2.7 to 3.0 V voltage range.
- No external termination series resistors are required on USB\_DP (D+) and USB\_DM (D-); the matching impedance is already included in the embedded driver.

### USB OTG\_HS characteristics

Unless otherwise specified, the parameters given in [Table 111](#) for ULPI are derived from tests performed under the ambient temperature,  $f_{rcc\_c\_ck}$  frequency and  $V_{DD}$  supply voltage conditions summarized in [Table 22: General operating conditions](#), with the following configuration:

- Output speed is set to OSPEEDRy[1:0] = 11
- Capacitive load C = 20 pF
- Measurement points are done at CMOS levels:  $0.5V_{DD}$ .

Refer to [Section 6.3.15: I/O port characteristics](#) for more details on the input/output characteristics.

**Table 111. Dynamic characteristics: USB ULPI<sup>(1)</sup>**

Symbol	Parameter	Conditions	Min	Typ	Max	Unit
$t_{SC}$	Control in (ULPI_DIR, ULPI_NXT) setup time	-	0.5	-	-	ns
$t_{HC}$	Control in (ULPI_DIR, ULPI_NXT) hold time	-	6.5	-	-	
$t_{SD}$	Data in setup time	-	2.5	-	-	
$t_{HD}$	Data in hold time	-	0	-	-	
$t_{DC}/t_{DD}$	Data/control output delay	$2.7\text{ V} < V_{DD} < 3.6\text{ V}$ , $C_L = 20\text{ pF}$	-	6.5	8.5	
		$1.7\text{ V} < V_{DD} < 3.6\text{ V}$ , $C_L = 15\text{ pF}$	-	6.5	13	

- Guaranteed by characterization results.

Figure 56. ULPI timing diagram

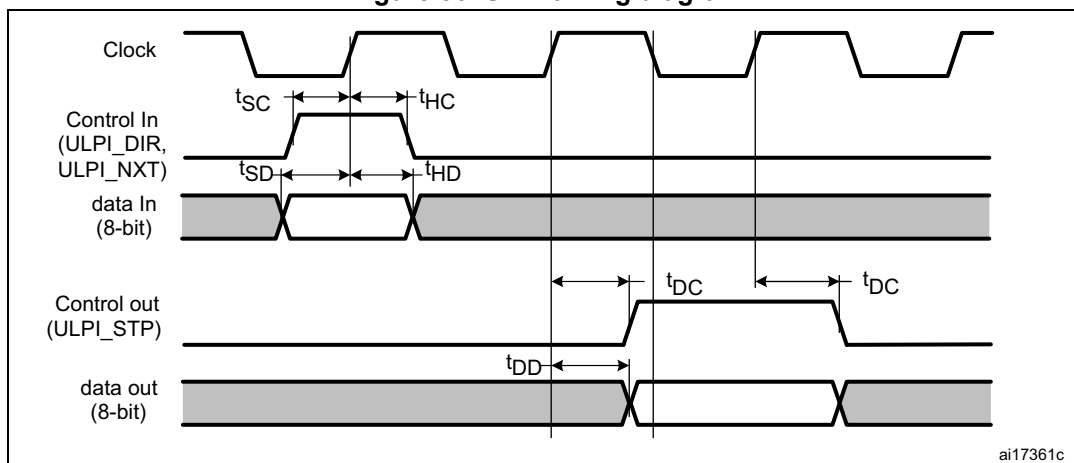

**Ethernet characteristics**

Unless otherwise specified, the parameters given in [Table 112](#), [Table 113](#) and [Table 114](#) for SMI, RMII and MII are derived from tests performed under the ambient temperature,  $f_{rcc\_c\_ck}$  frequency summarized in [Table 22: General operating conditions](#), with the following configuration:

- Output speed is set to  $OSPEEDRy[1:0] = 10$
- Capacitive load  $C = 20\text{ pF}$
- Measurement points are done at CMOS levels:  $0.5V_{DD}$ .

Refer to [Section 6.3.15: I/O port characteristics](#) for more details on the input/output characteristics.

[Table 112](#) gives the list of Ethernet MAC signals for the SMI and [Figure 57](#) shows the corresponding timing diagram.

**Table 112. Dynamics characteristics: Ethernet MAC signals for SMI<sup>(1)</sup>**

Symbol	Parameter	Min	Typ	Max	Unit
$t_{MDC}$	MDC cycle time(2.5 MHz)	400	400	403	ns
$T_{d(MDIO)}$	Write data valid time	1	1.5	3	
$t_{su(MDIO)}$	Read data setup time	8	-	-	
$t_{h(MDIO)}$	Read data hold time	0	-	-	

1. Guaranteed by characterization results.

Figure 57. Ethernet SMI timing diagram

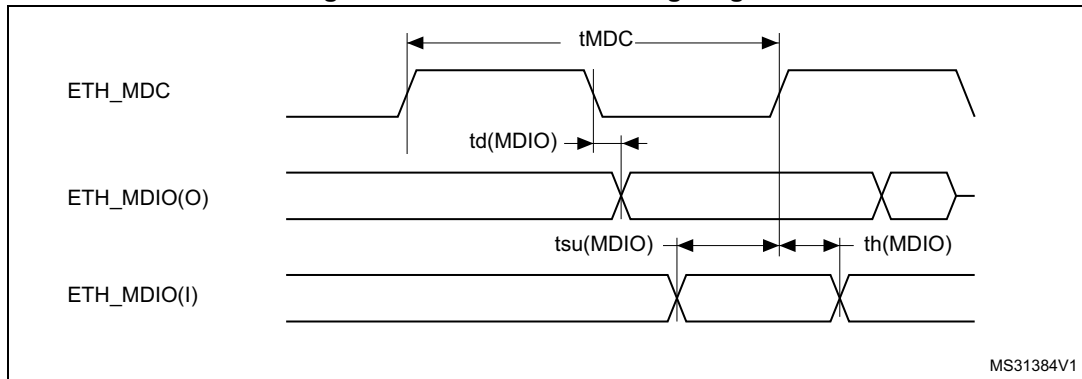

Table 113 gives the list of Ethernet MAC signals for the RMI and Figure 58 shows the corresponding timing diagram.

Table 113. Dynamics characteristics: Ethernet MAC signals for RMI(1)

Symbol	Parameter	Min	Typ	Max	Unit
$t_{su}(RXD)$	Receive data setup time	2	-	-	ns
$t_{ih}(RXD)$	Receive data hold time	3	-	-	
$t_{su}(CRS)$	Carrier sense setup time	2.5	-	-	
$t_{ih}(CRS)$	Carrier sense hold time	2	-	-	
$t_d(TXEN)$	Transmit enable valid delay time	4	4.5	7	
$t_d(TXD)$	Transmit data valid delay time	7	7.5	11.5	

1. Guaranteed by characterization results.

Figure 58. Ethernet RMI timing diagram

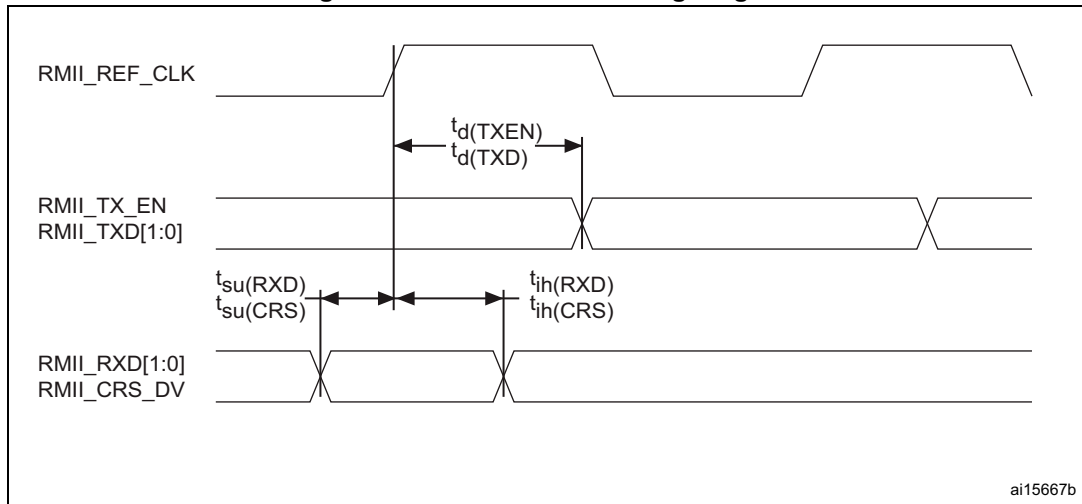

Table 114 gives the list of Ethernet MAC signals for MII and Figure 59 shows the corresponding timing diagram.

**Table 114. Dynamics characteristics: Ethernet MAC signals for MII<sup>(1)</sup>**

Symbol	Parameter	Min	Typ	Max	Unit
$t_{su}(RXD)$	Receive data setup time	2	-	-	ns
$t_{ih}(RXD)$	Receive data hold time	3	-	-	
$t_{su}(DV)$	Data valid setup time	1.5	-	-	
$t_{ih}(DV)$	Data valid hold time	1	-	-	
$t_{su}(ER)$	Error setup time	1.5	-	-	
$t_{ih}(ER)$	Error hold time	0.5	-	-	
$t_d(TXEN)$	Transmit enable valid delay time	4.5	6.5	11	
$t_d(TXD)$	Transmit data valid delay time	7	7.5	15	

1. Guaranteed by characterization results.

**Figure 59. Ethernet MII timing diagram**

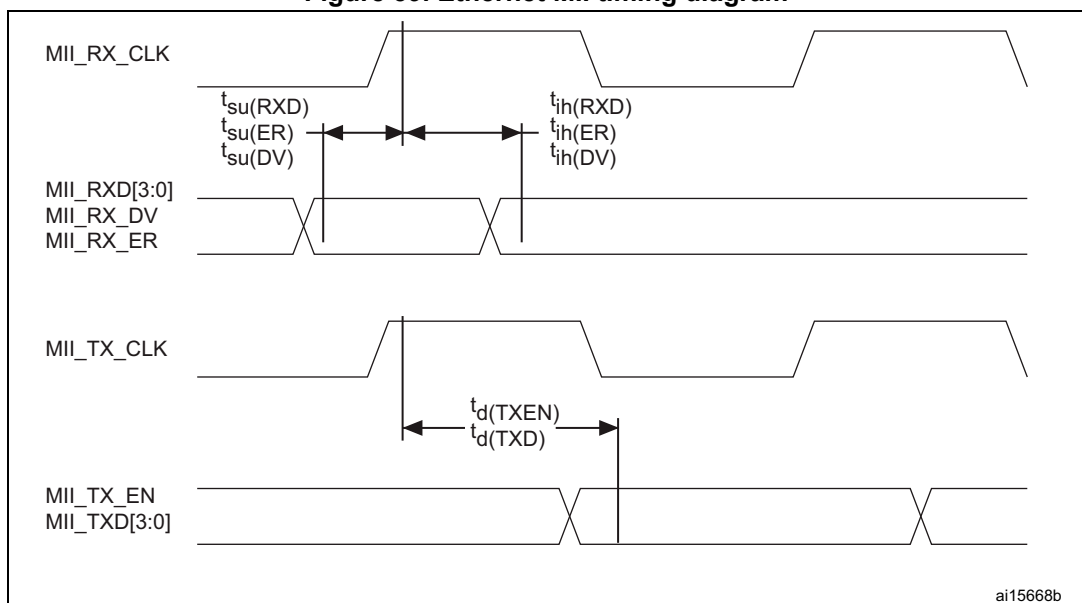

### 6.3.33 JTAG/SWD interface characteristics

Unless otherwise specified, the parameters given in [Table 115](#) and [Table 116](#) for JTAG/SWD are derived from tests performed under the ambient temperature,  $f_{rcc\_c\_ck}$  frequency and  $V_{DD}$  supply voltage summarized in [Table 22: General operating conditions](#), with the following configuration:

- Output speed is set to OSPEEDRy[1:0] = 0x10
- Capacitive load C=30 pF
- Measurement points are done at CMOS levels:  $0.5V_{DD}$

Refer to [Section 6.3.15: I/O port characteristics](#) for more details on the input/output characteristics.

Table 115. Dynamics JTAG characteristics<sup>(1)</sup>

Symbol	Parameter	Conditions	Min	Typ	Max	Unit
$F_{pp}$	$T_{CK}$ clock frequency	$2.7\text{ V} < V_{DD} < 3.6\text{ V}$	-	-	37	MHz
$1/t_{c(TCK)}$		$1.62\text{ V} < V_{DD} < 3.6\text{ V}$	-	-	27.5	
$t_{i_{su}(TMS)}$	TMS input setup time	-	2	-	-	ns
$t_{i_{h}(TMS)}$	TMS input hold time	-	1	-	-	
$t_{i_{su}(TDI)}$	TDI input setup time	-	1.5	-	-	
$t_{i_{h}(TDI)}$	TDI input hold time	-	1	-	-	
$t_{ov}(TDO)$	TDO output valid time	$2.7\text{ V} < V_{DD} < 3.6\text{ V}$	-	8	13.5	
		$1.62\text{ V} < V_{DD} < 3.6\text{ V}$	-	8	18	
$t_{oh}(TDO)$	TDO output hold time	-	7	-	-	

1. Guaranteed by characterization results.

Table 116. Dynamics SWD characteristics<sup>(1)</sup>

Symbol	Parameter	Conditions	Min	Typ	Max	Unit
$F_{pp}$	SWCLK clock frequency	$2.7\text{ V} < V_{DD} < 3.6\text{ V}$	-	-	71	MHz
$1/t_{c(SWCLK)}$		$1.62\text{ V} < V_{DD} < 3.6\text{ V}$	-	-	55.5	
$t_{i_{su}(SWDIO)}$	SWDIO input setup time	-	2.5	-	-	ns
$t_{i_{h}(SWDIO)}$	SWDIO input hold time	-	1	-	-	
$t_{ov}(SWDIO)$	SWDIO output valid time	$2.7\text{ V} < V_{DD} < 3.6\text{ V}$	-	8.5	14	
		$1.62\text{ V} < V_{DD} < 3.6\text{ V}$	-	8.5	18	
$t_{oh}(SWDIO)$	SWDIO output hold time	-	8	-	-	

1. Guaranteed by characterization results.

Figure 60. JTAG timing diagram

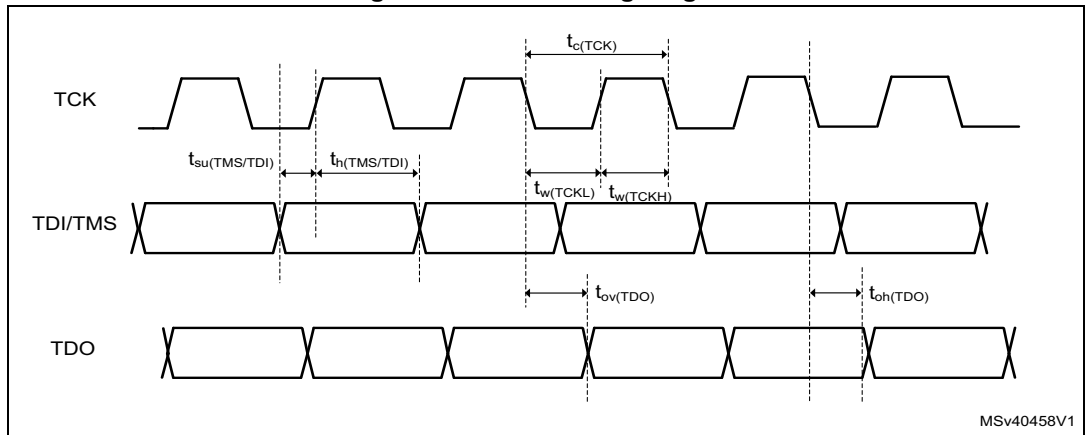
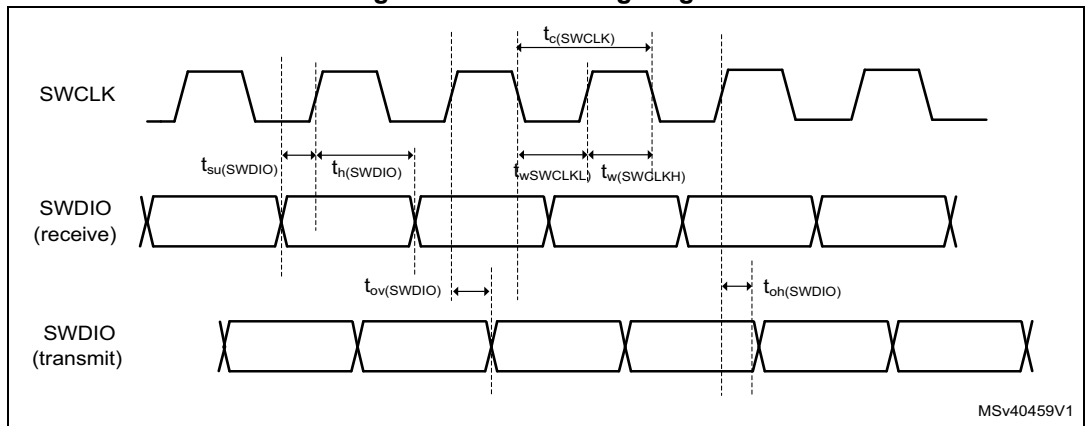

Figure 61. SWD timing diagram



## 7 Electrical characteristics (rev V)

### 7.1 Parameter conditions

Unless otherwise specified, all voltages are referenced to  $V_{SS}$ .

#### 7.1.1 Minimum and maximum values

Unless otherwise specified the minimum and maximum values are guaranteed in the worst conditions of junction temperature, supply voltage and frequencies by tests in production on 100% of the devices with an junction temperature at  $T_J = 25\text{ °C}$  and  $T_J = T_{Jmax}$  (given by the selected temperature range).

Data based on characterization results, design simulation and/or technology characteristics are indicated in the table footnotes. Based on characterization, the minimum and maximum values refer to sample tests and represent the mean value plus or minus three times the standard deviation ( $\text{mean} \pm 3\sigma$ ).

#### 7.1.2 Typical values

Unless otherwise specified, typical data are based on  $T_J = 25\text{ °C}$ ,  $V_{DD} = 3.3\text{ V}$  (for the  $1.7\text{ V} \leq V_{DD} \leq 3.6\text{ V}$  voltage range). They are given only as design guidelines and are not tested.

Typical ADC accuracy values are determined by characterization of a batch of samples from a standard diffusion lot over the full temperature range, where 95% of the devices have an error less than or equal to the value indicated ( $\text{mean} \pm 2\sigma$ ).

#### 7.1.3 Typical curves

Unless otherwise specified, all typical curves are given only as design guidelines and are not tested.

#### 7.1.4 Loading capacitor

The loading conditions used for pin parameter measurement are shown in [Figure 62](#).

#### 7.1.5 Pin input voltage

The input voltage measurement on a pin of the device is described in [Figure 63](#).

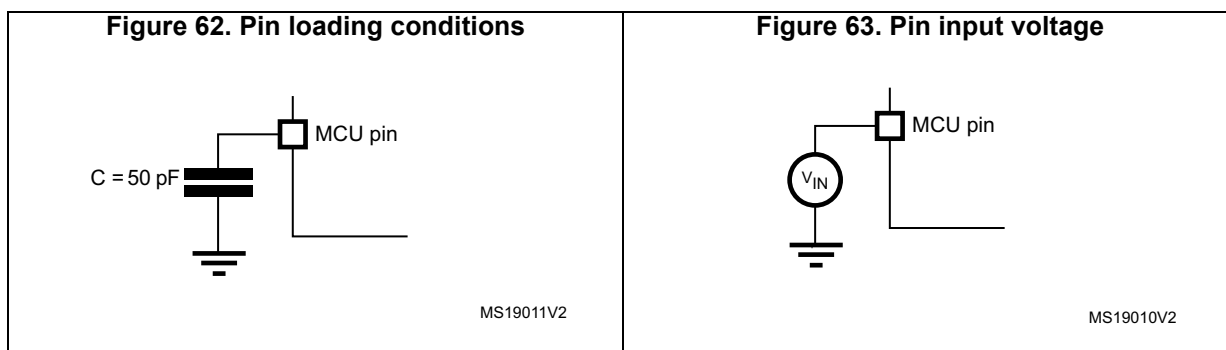



7.1.6 Power supply scheme

Figure 64. Power supply scheme

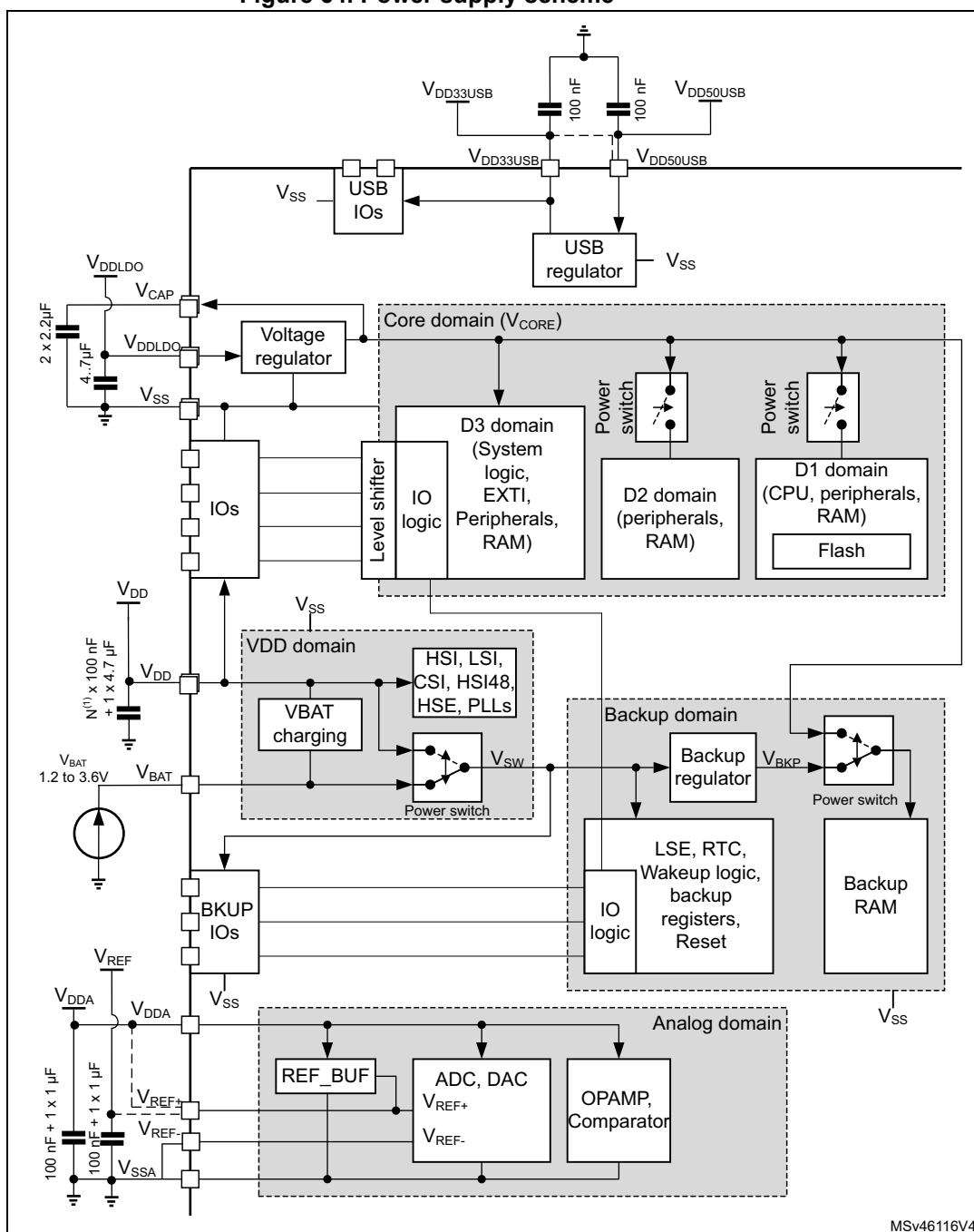

MSv46116V4

1. N corresponds to the number of VDD pins available on the package.
2. A tolerance of +/- 20% is acceptable on decoupling capacitors.

**Caution:** Each power supply pair ( $V_{DD}/V_{SS}$ ,  $V_{DDA}/V_{SSA}$  ...) must be decoupled with filtering ceramic capacitors as shown above. These capacitors must be placed as close as possible to, or below, the appropriate pins on the underside of the PCB to ensure good operation of the

device. It is not recommended to remove filtering capacitors to reduce PCB size or cost. This might cause incorrect operation of the device.

### 7.1.7 Current consumption measurement

Figure 65. Current consumption measurement scheme

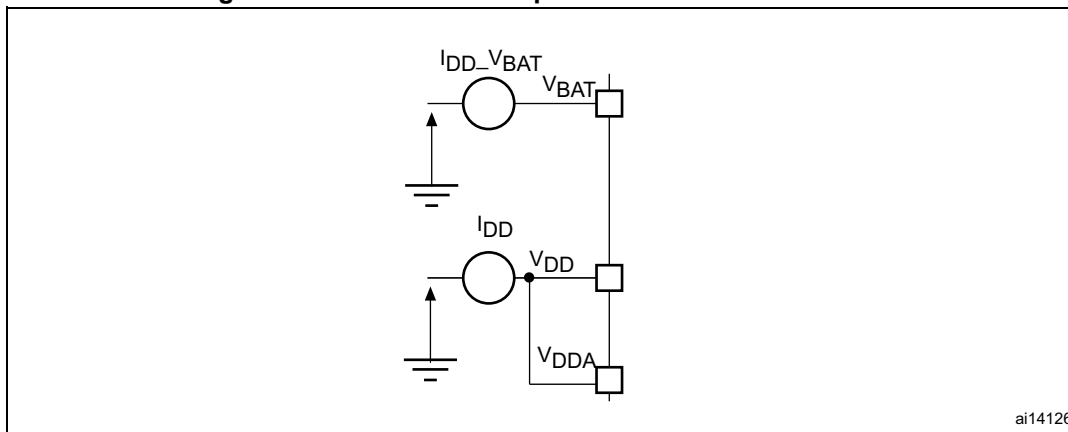

## 7.2 Absolute maximum ratings

Stresses above the absolute maximum ratings listed in [Table 117: Voltage characteristics](#), [Table 118: Current characteristics](#), and [Table 119: Thermal characteristics](#) may cause permanent damage to the device. These are stress ratings only and the functional operation of the device at these conditions is not implied. Exposure to maximum rating conditions for extended periods may affect device reliability. Device mission profile (application conditions) is compliant with JEDEC JESD47 Qualification Standard, extended mission profiles are available on demand.

Table 117. Voltage characteristics (1)

Symbols	Ratings	Min	Max	Unit
$V_{DDX} - V_{SS}$	External main supply voltage (including $V_{DD}$ , $V_{DDLDO}$ , $V_{DDA}$ , $V_{DD33USB}$ , $V_{BAT}$ )	-0.3	4.0	V
$V_{IN}^{(2)}$	Input voltage on FT_xxx pins	$V_{SS}-0.3$	$\text{Min}(V_{DD}, V_{DDA}, V_{DD33USB}, V_{BAT}) + 4.0^{(3)(4)}$	V
	Input voltage on TT_xx pins	$V_{SS}-0.3$	4.0	V
	Input voltage on BOOT0 pin	$V_{SS}$	9.0	V
	Input voltage on any other pins	$V_{SS}-0.3$	4.0	V
$ \Delta V_{DDX} $	Variations between different $V_{DDX}$ power pins of the same domain	-	50	mV
$ V_{SSx}-V_{SS} $	Variations between all the different ground pins	-	50	mV

- All main power ( $V_{DD}$ ,  $V_{DDA}$ ,  $V_{DD33USB}$ ,  $V_{BAT}$ ) and ground ( $V_{SS}$ ,  $V_{SSA}$ ) pins must always be connected to the external power supply, in the permitted range.
- $V_{IN}$  maximum must always be respected. Refer to [Table 154: I/O current injection susceptibility](#) for the maximum allowed injected current values.

3. This formula has to be applied on power supplies related to the IO structure described by the pin definition table.
4. To sustain a voltage higher than 4V the internal pull-up/pull-down resistors must be disabled.

**Table 118. Current characteristics**

Symbols	Ratings	Max	Unit
$\Sigma IV_{DD}$	Total current into sum of all $V_{DD}$ power lines (source) <sup>(1)</sup>	620	mA
$\Sigma IV_{SS}$	Total current out of sum of all $V_{SS}$ ground lines (sink) <sup>(1)</sup>	620	
$IV_{DD}$	Maximum current into each $V_{DD}$ power pin (source) <sup>(1)</sup>	100	
$IV_{SS}$	Maximum current out of each $V_{SS}$ ground pin (sink) <sup>(1)</sup>	100	
$I_{IO}$	Output current sunk by any I/O and control pin	20	
$\Sigma I_{(PIN)}$	Total output current sunk by sum of all I/Os and control pins <sup>(2)</sup>	140	
	Total output current sourced by sum of all I/Os and control pins <sup>(2)</sup>	140	
$I_{INJ(PIN)}^{(3)(4)}$	Injected current on FT_xxx, TT_xx, RST and B pins except PA4, PA5	-5/+0	
	Injected current on PA4, PA5	-0/0	
$\Sigma I_{INJ(PIN)}$	Total injected current (sum of all I/Os and control pins) <sup>(5)</sup>	±25	

1. All main power ( $V_{DD}$ ,  $V_{DDA}$ ,  $V_{DD33USB}$ ) and ground ( $V_{SS}$ ,  $V_{SSA}$ ) pins must always be connected to the external power supplies, in the permitted range.
2. This current consumption must be correctly distributed over all I/Os and control pins. The total output current must not be sunk/sourced between two consecutive power supply pins referring to high pin count QFP packages.
3. Positive injection is not possible on these I/Os and does not occur for input voltages lower than the specified maximum value.
4. A positive injection is induced by  $V_{IN} > V_{DD}$  while a negative injection is induced by  $V_{IN} < V_{SS}$ .  $I_{INJ(PIN)}$  must never be exceeded. Refer also to [Table 117: Voltage characteristics](#) for the maximum allowed input voltage values.
5. When several inputs are submitted to a current injection, the maximum  $\Sigma I_{INJ(PIN)}$  is the absolute sum of the positive and negative injected currents (instantaneous values).

**Table 119. Thermal characteristics**

Symbol	Ratings	Value	Unit
$T_{STG}$	Storage temperature range	? 65 to +150	°C
$T_J$	Maximum junction temperature	125	

## 7.3 Operating conditions

### 7.3.1 General operating conditions

Table 120. General operating conditions

Symbol	Parameter	Operating conditions	Min	Typ	Max	Unit
$V_{DD}$	Standard operating voltage	-	1.62 <sup>(1)</sup>	-	3.6	V
$V_{DDLDO}$	Supply voltage for the internal regulator	$V_{DDLDO} \leq V_{DD}$	1.62 <sup>(1)</sup>	-	3.6	
$V_{DD33USB}$	Standard operating voltage, USB domain	USB used	3.0	-	3.6	
		USB not used	0	-	3.6	
$V_{DDA}$	Analog operating voltage	ADC or COMP used	1.62	-	3.6	V
		DAC used	1.8	-		
		OPAMP used	2.0	-		
		VREFBUF used	1.8	-		
		ADC, DAC, OPAMP, COMP, VREFBUF not used	0	-		
$V_{IN}$	I/O Input voltage	TT_xx I/O	-0.3	-	$V_{DD}+0.3$	
		BOOT0	0	-	9	
		All I/O except BOOT0 and TT_xx	-0.3	-	$\text{Min}(V_{DD}, V_{DDA}, V_{DD33USB}) + 3.6V < 5.5V^{(2)(3)}$	
$V_{CORE}$	Internal regulator ON (LDO)	VOS3 (max frequency 200 MHz)	0.95	1.0	1.26	V
		VOS2 (max frequency 300 MHz)	1.05	1.10	1.26	
		VOS1 (max frequency 400 MHz)	1.15	1.20	1.26	
		VOS0 <sup>(4)</sup> (max frequency 480 MHz <sup>(5)</sup> )	1.26	1.35	1.40	
	Regulator OFF: external $V_{CORE}$ voltage must be supplied from external regulator on two VCAP pins	VOS3 (max frequency 200 MHz)	0.98	1.03	1.26	
		VOS2 (max frequency 300 MHz)	1.08	1.13	1.26	
		VOS1 (max frequency 400 MHz)	1.17	1.23	1.26	
		VOS0 (max frequency 480 MHz <sup>(5)</sup> )	1.37	1.38	1.40	

Table 120. General operating conditions (continued)

Symbol	Parameter	Operating conditions	Min	Typ	Max	Unit
f <sub>CPU</sub>	Arm® Cortex®-M7 clock frequency	VOS3	-	-	200	MHz
		VOS2	-	-	300	
		VOS1	-	-	400	
		VOS0	-	-	480 <sup>(5)</sup>	
f <sub>HCLK</sub>	AHB clock frequency	VOS3	-	-	100	
		VOS2	-	-	150	
		VOS1	-	-	200	
		VOS0	-	-	240 <sup>(5)</sup>	
f <sub>PCLK</sub>	APB clock frequency	VOS3	-	-	50 <sup>(6)</sup>	
		VOS2	-	-	75	
		VOS1	-	-	100	
		VOS0	-	-	120 <sup>(5)</sup>	
T <sub>A</sub>	Ambient temperature for the suffix 6 version	Maximum power dissipation		-40	85	
		Low-power dissipation <sup>(7)</sup>		-40	105	
T <sub>J</sub>	Junction temperature range	Suffix 6 version		-40	125	°C

- When RESET is released functionality is guaranteed down to V<sub>BOR0</sub> min
- This formula has to be applied on power supplies related to the IO structure described by the pin definition table.
- For operation with voltage higher than Min (V<sub>DD</sub>, V<sub>DDA</sub>, V<sub>DD33USB</sub>) +0.3V, the internal Pull-up and Pull-Down resistors must be disabled.
- VOS0 is available only when the LDO regulator is ON.
- T<sub>Jmax</sub> = 105 °C.
- Maximum APB clock frequency when at least one peripheral is enabled.
- In low-power dissipation state, T<sub>A</sub> can be extended to this range as long as T<sub>J</sub> does not exceed T<sub>Jmax</sub> (see [Section 8.6: Thermal characteristics](#)).

Table 121. Supply voltage and maximum frequency configuration

Power scale	V <sub>CORE</sub> source	Max T <sub>J</sub> (°C)	Max frequency (MHz)	Min V <sub>DD</sub> (V)
VOS0	LDO	105	480	1.7
VOS1	LDO	125	400	1.62
VOS2	LDO	125	300	1.62
VOS3	LDO	125	200	1.62
SVOS4	LDO	105	N/A	1.62
SVOS5	LDO	105	N/A	1.62

### 7.3.2 VCAP external capacitor

Stabilization for the main regulator is achieved by connecting an external capacitor  $C_{EXT}$  to the VCAP pin.  $C_{EXT}$  is specified in [Table 122](#). Two external capacitors can be connected to VCAP pins.

Figure 66. External capacitor  $C_{EXT}$

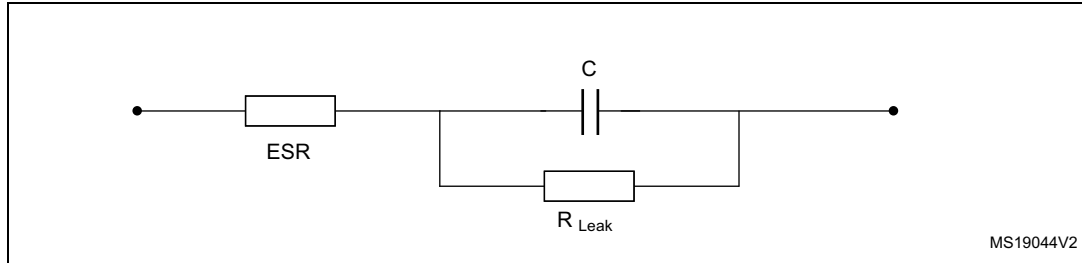

1. Legend: ESR is the equivalent series resistance.

Table 122. VCAP operating conditions<sup>(1)</sup>

Symbol	Parameter	Conditions
C <sub>EXT</sub>	Capacitance of external capacitor	2.2 $\mu$ F <sup>(2)</sup>
ESR	ESR of external capacitor	< 100 m $\Omega$

1. When bypassing the voltage regulator, the two 2.2  $\mu$ F V<sub>CAP</sub> capacitors are not required and should be replaced by two 100 nF decoupling capacitors.
2. This value corresponds to C<sub>EXT</sub> typical value. A variation of +/-20% is tolerated.

### 7.3.3 Operating conditions at power-up / power-down

Subject to general operating conditions for T<sub>A</sub>.

Table 123. Operating conditions at power-up / power-down (regulator ON)

Symbol	Parameter	Min	Max	Unit
t <sub>VDD</sub>	V <sub>DD</sub> rise time rate	0	$\infty$	$\mu$ s/V
	V <sub>DD</sub> fall time rate	10	$\infty$	
t <sub>VDDA</sub>	V <sub>D<sub>DA</sub></sub> rise time rate	0	$\infty$	
	V <sub>D<sub>DA</sub></sub> fall time rate	10	$\infty$	
t <sub>VDDUSB</sub>	V <sub>D<sub>DU</sub>SB</sub> rise time rate	0	$\infty$	
	V <sub>D<sub>DU</sub>SB</sub> fall time rate	10	$\infty$	

### 7.3.4 Embedded reset and power control block characteristics

The parameters given in [Table 124](#) are derived from tests performed under ambient temperature and  $V_{DD}$  supply voltage conditions summarized in [Table 120: General operating conditions](#).

**Table 124. Reset and power control block characteristics**

Symbol	Parameter	Conditions	Min	Typ	Max	Unit
$t_{RSTTEMPO}^{(1)}$	Reset temporization after BOR0 released	-	-	377	-	$\mu s$
$V_{BOR0}$	Brown-out reset threshold 0	Rising edge <sup>(1)</sup>	1.62	1.67	1.71	V
		Falling edge	1.58	1.62	1.68	
$V_{BOR1}$	Brown-out reset threshold 1	Rising edge	2.04	2.10	2.15	
		Falling edge	1.95	2.00	2.06	
$V_{BOR2}$	Brown-out reset threshold 2	Rising edge	2.34	2.41	2.47	
		Falling edge	2.25	2.31	2.37	
$V_{BOR3}$	Brown-out reset threshold 3	Rising edge	2.63	2.70	2.78	
		Falling edge	2.54	2.61	2.68	
$V_{PVD0}$	Programmable Voltage Detector threshold 0	Rising edge	1.90	1.96	2.01	
		Falling edge	1.81	1.86	1.91	
$V_{PVD1}$	Programmable Voltage Detector threshold 1	Rising edge	2.05	2.10	2.16	
		Falling edge	1.96	2.01	2.06	
$V_{PVD2}$	Programmable Voltage Detector threshold 2	Rising edge	2.19	2.26	2.32	
		Falling edge	2.10	2.15	2.21	
$V_{PVD3}$	Programmable Voltage Detector threshold 3	Rising edge	2.35	2.41	2.47	
		Falling edge	2.25	2.31	2.37	
$V_{PVD4}$	Programmable Voltage Detector threshold 4	Rising edge	2.49	2.56	2.62	
		Falling edge	2.39	2.45	2.51	
$V_{PVD5}$	Programmable Voltage Detector threshold 5	Rising edge	2.64	2.71	2.78	
		Falling edge	2.55	2.61	2.68	
$V_{PVD6}$	Programmable Voltage Detector threshold 6	Rising edge	2.78	2.86	2.94	
		Falling edge in Run mode	2.69	2.76	2.83	
$V_{hyst\_BOR\_PVD}$	Hysteresis voltage of BOR (unless BOR0) and PVD	Hysteresis in Run mode	-	100	-	mV
$I_{DD\_BOR\_PVD}^{(1)}$	BOR <sup>(2)</sup> (unless BOR0) and PVD consumption from $V_{DD}$	-	-	-	0.630	$\mu A$

Table 124. Reset and power control block characteristics (continued)

Symbol	Parameter	Conditions	Min	Typ	Max	Unit
$V_{AVM\_0}$	Analog voltage detector for $V_{DDA}$ threshold 0	Rising edge	1.66	1.71	1.76	V
		Falling edge	1.56	1.61	1.66	
$V_{AVM\_1}$	Analog voltage detector for $V_{DDA}$ threshold 1	Rising edge	2.06	2.12	2.19	
		Falling edge	1.96	2.02	2.08	
$V_{AVM\_2}$	Analog voltage detector for $V_{DDA}$ threshold 2	Rising edge	2.42	2.50	2.58	
		Falling edge	2.35	2.42	2.49	
$V_{AVM\_3}$	Analog voltage detector for $V_{DDA}$ threshold 3	Rising edge	2.74	2.83	2.91	
		Falling edge	2.64	2.72	2.80	
$V_{hyst\_VDDA}$	Hysteresis of $V_{DDA}$ voltage detector	-	-	100	-	mV
$I_{DD\_PVM}$	PVM consumption from $V_{DD(1)}$	-	-	-	0.25	$\mu$ A
$I_{DD\_VDDA}$	Voltage detector consumption on $V_{DDA}^{(1)}$	Resistor bridge	-	-	2.5	$\mu$ A

1. Guaranteed by design.

2. BOR0 is enabled in all modes and its consumption is therefore included in the supply current characteristics tables (refer to [Section 7.3.6: Supply current characteristics](#)).

### 7.3.5 Embedded reference voltage

The parameters given in [Table 125](#) are derived from tests performed under ambient temperature and  $V_{DD}$  supply voltage conditions summarized in [Table 120: General operating conditions](#).

Table 125. Embedded reference voltage

Symbol	Parameter	Conditions	Min	Typ	Max	Unit
$V_{REFINT}$	Internal reference voltages	$-40^{\circ}\text{C} < T_J < 125^{\circ}\text{C}$ , $V_{DD} = 3.3\text{ V}$	1.180	1.216	1.255	V
$t_{S\_vrefint}^{(1)(2)}$	ADC sampling time when reading the internal reference voltage	-	4.3	-	-	$\mu$ s
$t_{S\_vbat}^{(1)(2)}$	VBAT sampling time when reading the internal VBAT reference voltage	-	9	-	-	
$I_{refbuf}^{(2)}$	Reference Buffer consumption for ADC	$V_{DDA} = 3.3\text{ V}$	9	13.5	23	$\mu$ A
$\Delta V_{REFINT}^{(2)}$	Internal reference voltage spread over the temperature range	$-40^{\circ}\text{C} < T_J < 125^{\circ}\text{C}$	-	5	15	mV
$T_{coeff}^{(2)}$	Average temperature coefficient	Average temperature coefficient	-	20	70	ppm/ $^{\circ}\text{C}$
$V_{DDcoeff}^{(2)}$	Average Voltage coefficient	$3.0\text{V} < V_{DD} < 3.6\text{V}$	-	10	1370	ppm/V



Table 125. Embedded reference voltage (continued)

Symbol	Parameter	Conditions	Min	Typ	Max	Unit
V <sub>REFINT_DIV1</sub>	1/4 reference voltage	-	-	25	-	% V <sub>REFINT</sub>
V <sub>REFINT_DIV2</sub>	1/2 reference voltage	-	-	50	-	
V <sub>REFINT_DIV3</sub>	3/4 reference voltage	-	-	75	-	

1. The shortest sampling time for the application can be determined by multiple iterations.
2. Guaranteed by design.

Table 126. Internal reference voltage calibration values

Symbol	Parameter	Memory address
V <sub>REFIN_CAL</sub>	Raw data acquired at temperature of 30 °C, V <sub>DDA</sub> = 3.3 V	1FF1E860 - 1FF1E861

### 7.3.6 Supply current characteristics

The current consumption is a function of several parameters and factors such as the operating voltage, ambient temperature, I/O pin loading, device software configuration, operating frequencies, I/O pin switching rate, program location in memory and executed binary code.

The current consumption is measured as described in [Figure 65: Current consumption measurement scheme](#).

All the run-mode current consumption measurements given in this section are performed with a CoreMark code.

#### Typical and maximum current consumption

The MCU is placed under the following conditions:

- All I/O pins are in analog input mode.
- All peripherals are disabled except when explicitly mentioned.
- The Flash memory access time is adjusted with the minimum wait states number, depending on the  $f_{\text{ACLK}}$  frequency (refer to the table “Number of wait states according to CPU clock ( $f_{\text{rcc\_c\_ck}}$ ) frequency and V<sub>CORE</sub> range” available in the reference manual).
- When the peripherals are enabled, the AHB clock frequency is the CPU frequency divided by 2 and the APB clock frequency is AHB clock frequency divided by 2.

The parameters given in the below tables are derived from tests performed under ambient temperature and supply voltage conditions summarized in [Table 120: General operating conditions](#).

**Table 127. Typical and maximum current consumption in Run mode, code with data processing running from ITCM, LDO regulator ON<sup>(1)</sup>**

Symbol	Parameter	Conditions	f <sub>HCLK</sub> (MHz)	Typ	Max <sup>(2)</sup>				Unit	
					T <sub>j</sub> =25 °C	T <sub>j</sub> =85 °C	T <sub>j</sub> =105 °C	T <sub>j</sub> =125 °C		
I <sub>DD</sub>	Supply current in Run mode	All peripherals disabled	VOS0	480	148	226	307	390	-	mA
				400	125	-	-	-	-	
			VOS1	400	110	168	230	296	384	
				300	84	-	-	-	-	
			VOS2	300	76	114	170	224	297	
				216	56	88	152	205	278	
			VOS3	200	53	-	-	-	-	
				200	47	71	121	164	223	
				180	43	64	116	159	218	
				168	40	63	115	158	217	
		144		35	55	109	153	212		
		60		16	36	92	135	194		
		All peripherals enabled	VOS0	25	12	24	83	126	185	
				480	226	348	439	550	-	
			VOS1	400	190	-	-	-	-	
				400	167	256	327	416	536	
			VOS2	300	135	-	-	-	-	
				300	122	183	248	320	419	
			VOS3	200	85	-	-	-	-	
				200	76	116	174	233	313	

1. Data are in DTCM for best computation performance, the cache has no influence on consumption in this case.
2. Guaranteed by characterization results, unless otherwise specified.

**Table 128. Typical and maximum current consumption in Run mode, code with data processing running from Flash memory, cache ON, LDO regulator ON**

Symbol	Parameter	Conditions	f <sub>HCLK</sub> (MHz)	Typ	Max <sup>(1)</sup>				Unit	
					T <sub>j</sub> =25 °C	T <sub>j</sub> =85 °C	T <sub>j</sub> =105 °C	T <sub>j</sub> =125 °C		
I <sub>DD</sub>	Supply current in Run mode	All peripherals disabled	VOS0	480	110	222	304	388	-	mA
				400	91	-	-	-	-	
			VOS1	400	80	162	228	294	381	
				300	61.5	-	-	-	-	
			VOS2	300	55	111	168	222	294	
				200	38.5	-	-	-	-	
		VOS3	200	34.5	69	120	163	222		
			200	75	114	173	232	312		
		All peripherals enabled	VOS0	480	220	342	436	546	-	
				400	195	-	-	-	-	
			VOS1	400	175	264	336	424	544	
				300	135	-	-	-	-	
			VOS2	300	120	180	246	318	418	
				200	83	-	-	-	-	

1. Guaranteed by characterization results, unless otherwise specified.

**Table 129. Typical and maximum current consumption in Run mode, code with data processing running from Flash memory, cache OFF, LDO regulator ON**

Symbol	Parameter	Conditions	f <sub>HCLK</sub> (MHz)	Typ	Max <sup>(1)</sup>				Unit	
					T <sub>j</sub> =25 °C	T <sub>j</sub> =85 °C	T <sub>j</sub> =105 °C	T <sub>j</sub> =125 °C		
I <sub>DD</sub>	Supply current in Run mode	All peripherals disabled	VOS0	480	87	157	259	342	453	mA
			VOS1	400	73	123	201	267	355	
			VOS2	300	52	85	150	204	277	
			VOS3	200	34	54	109	152	212	
		All peripherals enabled	VOS0	480	168	276	390	504	658	
			VOS1	400	135	224	308	397	519	
			VOS2	300	100	154	228	301	401	
			VOS3	200	70	103	167	226	307	

1. Guaranteed by characterization results, unless otherwise specified.

**Table 130. Typical and maximum current consumption batch acquisition mode, LDO regulator ON**

Symbol	Parameter	Conditions		f <sub>HCLK</sub> (MHz)	Typ	Max <sup>(1)</sup>				Unit
						T <sub>j</sub> =25°C	T <sub>j</sub> =85°C	T <sub>j</sub> =105 °C	T <sub>j</sub> =125 °C	
I <sub>DD</sub>	Supply current in batch acquisition mode	D1 Standby, D2 Standby, D3 Run	VOS3	64	2.7	4.7	12.9	19.0	27.5	mA
				8	1.1	-	-	-	-	
		D1 Stop, D2 Stop, D3 Run	VOS3	64	5.4	18.4	83.7	132.6	202.4	
				8	3.8	-	-	-	-	

1. Guaranteed by characterization results, unless otherwise specified.

**Table 131. Typical and maximum current consumption in Stop, LDO regulator ON**

Symbol	Parameter	Conditions		Typ	Max <sup>(1)</sup>				Unit
					T <sub>j</sub> =25°C	T <sub>j</sub> =85°C	T <sub>j</sub> =105 °C	T <sub>j</sub> =125 °C	
I <sub>DD</sub> (Stop)	D1 Stop, D2 Stop, D3 Stop	Flash memory OFF, no IWDG	SVOS5	1.27	6.3	42.5	72.0	-	
			SVOS4	1.96	9.4	57.4	94.6	-	
			SVOS3	2.78	13.8	75.9	121.3	183.8	
		Flash memory ON, no IWDG	SVOS5	1.27	6.3	42.5	72.0	-	
			SVOS4	2.25	9.8	57.9	95.2	-	
			SVOS3	3.07	14.1	76.4	122.0	184.8	
	D1 Stop, D2 Standby, D3 Stop	Flash memory OFF, no IWDG	SVOS5	0.91	4.6	30.4	51.2	-	
			SVOS4	1.42	6.8	41.1	67.3	-	
			SVOS3	2.02	10.0	54.4	86.6	130.0	
		Flash memory ON, no IWDG	SVOS5	0.91	4.6	30.4	51.2	-	
			SVOS4	1.70	7.2	41.5	67.9	-	
			SVOS3	2.31	10.3	54.9	87.1	130.8	
	D1 Standby, D2 Stop, D3 Stop	Flash memory OFF, no IWDG	SVOS5	0.49	2.4	16.5	28.0	-	
			SVOS4	0.76	3.6	22.2	36.6	-	
			SVOS3	1.10	5.3	29.3	46.9	71.2	
	D1 Standby, D2 Standby, D3 Stop	Flash memory OFF, no IWDG	SVOS5	0.15	0.7	4.3	7.3	-	
			SVOS4	0.22	1.0	5.8	9.6	-	
			SVOS3	0.35	1.5	7.8	12.3	18.6	

1. Guaranteed by characterization results, unless otherwise specified.

**Table 132. Typical and maximum current consumption in Sleep mode, LDO regulator <sup>(1)</sup>**

Symbol	Parameter	Conditions	f <sub>HCLK</sub> (MHz)	Typ	Max <sup>(2)</sup>				Unit	
					T <sub>j</sub> =25 °C	T <sub>j</sub> =85 °C	T <sub>j</sub> =105 °C	T <sub>j</sub> =125 °C		
I <sub>DD</sub> (Sleep)	Supply current in Sleep mode	All peripherals disabled	VOS0	480	50.7	96.3	253.4	366.1		mA
				400	43.4	87.8	245.5	357.9		
			VOS1	400	35.3	66.5	181.3	265.8	379.6	
				300	27.9	-	-	-	-	
			VOS2	300	24.6	47.3	139.1	207.3	300.4	
				200	18.8	-	-	-	-	
		VOS3	200	16.5	33.6	106.4	160.9	236.1		
			All peripherals enabled	VOS0	480	136.0	194.7	348.5	464.4	
		400			115.0	169.0	325.9	441.7		
		VOS1		400	97.7	138.2	251.3	338.4	456.4	
				300	74.9	-	-	-	-	
		VOS2		300	67.3	95.8	187.6	257.9	354.1	
				200	52.8	-	-	-	-	
		VOS3	200	47.1	69.3	141.4	197.7	275.1		

1. The parameters given in the above table for the SMPS regulator are derived by extrapolation from the LDO consumption and typical SMPS efficiency factors.
2. Guaranteed by characterization results, unless otherwise specified.

**Table 133. Typical and maximum current consumption in Standby**

Symbol	Parameter	Conditions		Typ				Max <sup>(1)</sup>				Unit
				1.62 V	2.4 V	3 V	3.3 V	3 V				
		Backup SRAM	RTC and LSE					T <sub>j</sub> =25 °C	T <sub>j</sub> =85 °C	T <sub>j</sub> =105 °C	T <sub>j</sub> =125 °C	
I <sub>DD</sub> (Standby)	Supply current in Standby mode	OFF	OFF	1,92	1,95	2,06	2,16	4	18	40	90	µA
		ON	OFF	3,33	3,44	3,6	3,79	8.2	47	83	141	
		OFF	ON	2,43	2,57	2,77	2,95	-	-	-	-	
		ON	ON	3,82	4,05	4,31	4,55	-	-	-	-	

1. Guaranteed by characterization results, unless otherwise specified.

**Table 134. Typical and maximum current consumption in V<sub>BAT</sub> mode**

Symbol	Parameter	Conditions		Typ				Max <sup>(1)</sup>				Unit
		Backup SRAM	RTC and LSE	1.2 V	2 V	3 V	3.4 V	3 V				
								T <sub>j</sub> =25 °C	T <sub>j</sub> =85 °C	T <sub>j</sub> =105 °C	T <sub>j</sub> =125 °C	
I <sub>DD</sub> (VBAT)	Supply current in V <sub>BAT</sub> mode	OFF	OFF	0,02	0,02	0,03	0,05	0,5	4,1	10	24	µA
		ON	OFF	1,33	1,45	1,58	1,7	4,4	22	48	87	
		OFF	ON	0,46	0,57	0,75	0,87	-	-	-	-	
		ON	ON	1,77	2	2,3	2,5	-	-	-	-	

1. Guaranteed by characterization results, unless otherwise specified.

### I/O system current consumption

The current consumption of the I/O system has two components: static and dynamic.

#### I/O static current consumption

All the I/Os used as inputs with pull-up generate a current consumption when the pin is externally held low. The value of this current consumption can be simply computed by using the pull-up/pull-down resistors values given in [Table 155: I/O static characteristics](#).

For the output pins, any external pull-down or external load must also be considered to estimate the current consumption.

An additional I/O current consumption is due to I/Os configured as inputs if an intermediate voltage level is externally applied. This current consumption is caused by the input Schmitt trigger circuits used to discriminate the input value. Unless this specific configuration is required by the application, this supply current consumption can be avoided by configuring these I/Os in analog mode. This is notably the case of ADC input pins which should be configured as analog inputs.

**Caution:** Any floating input pin can also settle to an intermediate voltage level or switch inadvertently, as a result of external electromagnetic noise. To avoid a current consumption related to floating pins, they must either be configured in analog mode, or forced internally to a definite digital value. This can be done either by using pull-up/down resistors or by configuring the pins in output mode.

### I/O dynamic current consumption

In addition to the internal peripheral current consumption (see [Table 135: Peripheral current consumption in Run mode](#)), the I/Os used by an application also contribute to the current consumption. When an I/O pin switches, it uses the current from the MCU supply voltage to supply the I/O pin circuitry and to charge/discharge the capacitive load (internal or external) connected to the pin:

$$I_{SW} = V_{DDx} \times f_{SW} \times C_L$$

where

$I_{SW}$  is the current sunk by a switching I/O to charge/discharge the capacitive load

$V_{DDx}$  is the MCU supply voltage

$f_{SW}$  is the I/O switching frequency

$C_L$  is the total capacitance seen by the I/O pin:  $C = C_{INT} + C_{EXT}$

The test pin is configured in push-pull output mode and is toggled by software at a fixed frequency.

### On-chip peripheral current consumption

The MCU is placed under the following conditions:

- At startup, all I/O pins are in analog input configuration.
- All peripherals are disabled unless otherwise mentioned.
- The I/O compensation cell is enabled.
- $f_{rcc\_c\_ck}$  is the CPU clock.  $f_{PCLK} = f_{rcc\_c\_ck}/4$ , and  $f_{HCLK} = f_{rcc\_c\_ck}/2$ .  
The given value is calculated by measuring the difference of current consumption
  - with all peripherals clocked off
  - with only one peripheral clocked on
  - $f_{rcc\_c\_ck} = 480$  MHz (Scale 0),  $f_{rcc\_c\_ck} = 400$  MHz (Scale 1),  $f_{rcc\_c\_ck} = 300$  MHz (Scale 2),  $f_{rcc\_c\_ck} = 200$  MHz (Scale 3)
- The ambient operating temperature is 25 °C and  $V_{DD}=3.3$  V.

Table 135. Peripheral current consumption in Run mode

Bus	Peripheral	VOS0	VOS1	VOS2	VOS3	Unit
AHB3	MDMA	4.6	3.8	3.4	3.2	μA/MHz
	DMA2D	2.9	2.4	2.1	1.9	
	JPGDEC	4.1	3.7	3.4	3.1	
	FLASH	17.0	15.0	14.0	12.0	
	FMC registers	0.9	1.1	0.9	0.8	
	FMC kernel	7.0	6.1	5.6	5.0	
	QUADSPI registers	1.5	1.5	1.4	1.3	
	QSPI kernel	1.0	0.9	0.8	0.7	
	SDMMC1 registers	8.2	7.2	6.7	6.0	
	SDMMC1 kernel	1.3	1.2	0.9	0.9	
	DTCM1	7.9	6.8	6.0	5.3	
	DTCM2	8.3	7.2	6.4	5.7	
	ITCM	7.0	6.3	5.6	5.1	
	D1SRAM1	13.0	11.0	9.9	8.7	
	AHB3 bridge	35.0	32.0	29.0	26.0	
	<b>Total AHB3</b>	<b>120</b>	<b>106</b>	<b>96</b>	<b>86</b>	
AHB1	DMA1	54.0	48.0	41.0	37.0	
	DMA2	55.0	49.0	42.0	37.0	
	ADC12 registers	4.5	4.1	3.7	3.3	
	ADC12 kernel	1.0	0.7	0.4	0.6	
	ART accelerator	4.1	3.7	3.2	2.9	
	ETH1MAC	17.0	15.0	14.0	12.0	
	ETH1TX	0.1	0.1	0.1	0.1	
	ETH1RX	0.1	0.1	0.1	0.1	
	USB1 OTG registers	23.0	21.0	19.0	17.0	
	USB1 OTG kernel	8.2	0.5	8.3	8.2	
	USB1 ULPI	0.1	0.1	0.1	0.1	
	USB2 OTG registers	21.0	19.0	17.0	15.0	
	USB2 OTG kernel	8.5	0.4	8.6	8.3	
	USB2 ULPI	23.0	19.0	20.0	19.0	
	AHB1 bridge	0.1	0.1	0.1	0.1	
	<b>Total AHB1</b>	<b>220</b>	<b>181</b>	<b>178</b>	<b>161</b>	



Table 135. Peripheral current consumption in Run mode (continued)

Bus	Peripheral	VOS0	VOS1	VOS2	VOS3	Unit
AHB2	DCMI	2.1	1.9	1.8	1.6	μA/MHz
	CRYPT	0.1	0.1	0.1	0.1	
	HASH	0.1	0.1	0.1	0.1	
	RNG registers	1.7	2.0	1.3	1.2	
	RNG kernel	11.0	0.1	9.7	9.4	
	SDMMC2 registers	47.0	41.0	37.0	34.0	
	SDMMC2 kernel	1.7	1.2	1.1	1.0	
	D2SRAM1	5.7	4.9	4.4	3.9	
	D2SRAM2	5.2	4.5	4.0	3.5	
	D2SRAM3	4.1	3.6	3.2	2.8	
	AHB2 bridge	0.1	0.1	0.1	0.1	
	<b>Total AHB2</b>	<b>79</b>	<b>60</b>	<b>63</b>	<b>58</b>	
AHB4	GPIOA	1.5	1.3	1.3	1.1	μA/MHz
	GPIOB	1.2	1.0	1.0	0.9	
	GPIOC	0.8	0.7	0.7	0.6	
	GIPOD	1.1	1.0	1.0	0.9	
	GPIOE	0.7	0.7	0.7	0.6	
	GPIOF	0.8	0.8	0.7	0.6	
	GPIOG	0.9	0.8	0.8	0.7	
	GPIOH	1.1	1.0	1.0	0.9	
	GPIOI	0.9	0.9	0.8	0.7	
	GPIOJ	0.8	0.8	0.7	0.7	
	GPIOK	0.7	0.8	0.7	0.6	
	CRC	0.4	0.5	0.4	0.3	
	BDMA	6.6	5.9	5.3	4.8	
	ADC3 registers	1.7	1.5	1.2	1.2	
	ADC3 kernel	0.4	0.3	0.5	0.2	
	BKPRAM	2.3	1.9	1.7	1.5	
	AHB4 bridge	0.1	0.1	0.1	0.1	
	<b>Total AHB4</b>	<b>22</b>	<b>20</b>	<b>19</b>	<b>16</b>	
APB3	WWDG1	0.7	0.5	0.5	0.2	μA/MHz
	LCD-TFT	81.0	36.0	33.0	30.0	
	APB3 bridge	0.3	0.2	0.1	0.1	
	<b>Total APB3</b>	<b>87</b>	<b>41</b>	<b>38</b>	<b>34</b>	

**Table 135. Peripheral current consumption in Run mode (continued)**

Bus	Peripheral	VOS0	VOS1	VOS2	VOS3	Unit
APB1	TIM2	7.7	3.6	3.3	3.0	µA/MHz
	TIM3	6.7	3.2	3.0	2.7	
	TIM4	6.3	3.1	2.8	2.5	
	TIM5	7.4	3.5	3.2	2.8	
	TIM6	1.4	0.7	0.8	0.6	
	TIM7	1.4	0.7	0.7	0.6	
	TIM12	3.2	1.5	1.5	1.3	
	TIM13	2.3	1.1	1.1	0.9	
	TIM14	2.1	1.1	1.1	0.9	
	LPTIM1 registers	0.7	0.5	0.8	0.7	
	LPTIM1 kernel	2.4	2.3	1.9	1.7	
	WWDG2	0.6	0.5	0.5	0.4	
	SPI2 registers	2.0	1.8	1.7	1.4	
	SPI2 kernel	0.8	0.6	0.5	0.6	
	SPI3 registers	1.8	1.6	1.6	1.3	
	SPI3 kernel	0.7	0.9	0.7	0.7	
	SPDIFRX1 registers	0.5	0.7	0.7	0.6	
	SPDIFRX1 kernel	3.5	2.8	2.4	2.2	
	USART2 registers	1.9	1.7	1.4	1.3	
	USART2 kernel	4.3	3.9	3.6	3.2	
	USART3 registers	1.9	1.7	1.4	1.3	
	USART3 kernel	4.4	3.9	3.5	3.2	
	UART4 registers	1.7	1.5	1.4	1.4	
	UART4 kernel	3.9	3.4	3.1	2.8	
	UART5 registers	1.6	1.4	1.4	1.3	
	UART5 kernel	3.8	3.4	3.0	2.7	
	I2C1 registers	1.1	0.8	0.9	0.8	
	I2C1 kernel	2.5	2.3	2.0	1.9	
I2C2 registers	1.0	0.8	0.9	0.8		

**Table 135. Peripheral current consumption in Run mode (continued)**

Bus	Peripheral	VOS0	VOS1	VOS2	VOS3	Unit
APB1 (continued)	I2C2 kernel	2.3	2.2	1.9	1.7	μA/MHz
	I2C3 registers	0.8	1.0	0.8	0.8	
	I2C3 kernel	2.4	1.9	1.8	1.6	
	HDMI-CEC registers	0.7	0.5	0.6	0.5	
	HDMI-CEC kernel	0.1	0.1	3.2	0.1	
	DAC12	3.6	1.3	1.2	1.0	
	USART7 registers	1.8	1.8	1.6	1.4	
	USART7 kernel	4.0	3.3	3.0	2.8	
	USART8 registers	2.0	1.6	1.6	1.4	
	USART8 kernel	3.9	3.4	3.1	2.8	
	CRS	6.4	5.5	5.0	4.5	
	SWPMI registers	2.7	2.4	2.3	1.9	
	SWPMI kernel	0.1	0.1	0.1	0.1	
	OPAMP	0.2	0.3	0.3	0.2	
	MDIO	3.3	2.9	2.6	2.3	
	FDCAN registers	19.0	17.0	15.0	13.0	
	FDCAN kernel	9.1	7.9	6.9	6.4	
	APB1 bridge	0.1	0.1	0.1	0.1	
	<b>Total APB1</b>	<b>142</b>	<b>108</b>	<b>102</b>	<b>88</b>	
	APB2	TIM1	11.0	5.0	4.5	
TIM8		10.0	4.7	4.3	3.8	
USART1 registers		3.6	2.5	2.7	2.9	
USART1 kernel		0.1	0.1	0.1	0.1	
USART6 registers		4.5	3.0	3.1	3.4	
USART6 kernel		0.1	0.1	0.1	0.1	
SPI1 registers		2.0	1.7	1.6	1.4	
SPI1 kernel		0.9	0.8	0.7	0.6	
SPI4 registers		2.1	1.7	1.6	1.5	
SPI4 kernel		0.6	0.5	0.5	0.3	
TIM15		5.5	2.5	2.3	2.1	
TIM16		4.1	2.0	1.8	1.7	
TIM17		4.1	1.9	1.8	1.6	
SPI5 registers		2.0	1.8	1.6	1.3	
SPI5 kernel		0.5	0.4	0.4	0.5	
SAI1 registers		1.3	1.1	1.1	1.0	

**Table 135. Peripheral current consumption in Run mode (continued)**

Bus	Peripheral	VOS0	VOS1	VOS2	VOS3	Unit
APB2 (continued)	SAI1 kernel	1.4	1.1	1.0	0.8	μA/MHz
	SAI2 registers	1.5	1.3	1.2	1.0	
	SAI2 kernel	1.1	1.0	0.9	0.9	
	SAI3 registers	1.6	1.3	1.1	1.0	
	SAI3 kernel	1.1	1.2	1.1	0.9	
	DFSDM1 registers	6.5	5.8	5.2	4.7	
	DFSDM1 kernel	0.3	0.2	0.2	0.4	
	HRTIM	84.0	39.0	35.0	32.0	
	APB2 bridge	0.2	0.1	0.1	0.2	
	<b>Total APB2</b>	<b>150</b>	<b>81</b>	<b>74</b>	<b>68</b>	
APB4	SYSCFG	0.9	1.0	0.7	0.8	
	LPUART1 registers	1.1	1.3	1.0	0.8	
	LPUART1 kernel	2.9	2.2	2.2	2.1	
	SPI6 registers	1.8	1.6	1.4	1.3	
	SPI6 kernel	0.4	0.4	0.5	0.3	
	I2C4 registers	0.9	0.7	0.7	0.4	
	I2C4 kernel	2.2	2.1	1.9	1.8	
	LPTIM2 registers	0.8	0.6	0.7	0.5	
	LPTIM2 kernel	2.3	2.1	1.8	1.4	
	LPTIM3 registers	0.7	0.7	0.7	0.4	
	LPTIM3 kernel	2.1	1.7	1.6	1.5	
	LPTIM4 registers	0.8	0.4	0.6	0.4	
	LPTIM4 kernel	2.2	2.0	1.7	1.5	
	LPTIM5 registers	0.5	0.4	0.6	0.4	
	LPTIM5 kernel	2.0	1.8	1.5	1.2	
	COMP12	0.6	0.4	0.5	0.2	
	VREF	0.4	0.2	0.2	0.1	
	RTC	1.1	0.9	1.0	0.6	
	SAI4 registers	1.7	1.4	1.3	1.0	
	SAI4 kernel	2.0	2.0	1.8	1.6	
APB4 bridge	0.1	0.1	0.1	0.1		
<b>Total APB4</b>	<b>28</b>	<b>24.4</b>	<b>22.4</b>	<b>18.9</b>		

### 7.3.7 Wakeup time from low-power modes

The wakeup times given in [Table 136](#) are measured starting from the wakeup event trigger up to the first instruction executed by the CPU:

- For Stop or Sleep modes: the wakeup event is WFE.
- WKUP (PC1) pin is used to wakeup from Standby, Stop and Sleep modes.

All timings are derived from tests performed under ambient temperature and  $V_{DD}=3.3\text{ V}$ .

**Table 136. Low-power mode wakeup timings**

Symbol	Parameter	Conditions	Typ <sup>(1)</sup>	Max <sup>(1)</sup>	Unit
$t_{WUSLEEP}^{(2)}$	Wakeup from Sleep	-	9	10	CPU clock cycles
$t_{WUSTOP}^{(2)}$	Wakeup from Stop	VOS3, HSI, Flash memory in normal mode	4.4	5.6	$\mu\text{s}$
		VOS3, HSI, Flash memory in low-power mode	12	15	
		VOS4, HSI, Flash memory in normal mode	15	20	
		VOS4, HSI, Flash memory in low-power mode	23	28	
		VOS5, HSI, Flash memory in normal mode	39	71	
		VOS5, HSI, Flash memory in low-power mode	39	47	
		VOS3, CSI, Flash memory in normal mode	30	37	
		VOS3, CSI, Flash memory in low power mode	36	50	
		VOS4, CSI, Flash memory in normal mode	38	48	
		VOS4, CSI, Flash memory in low-power mode	47	61	
		VOS5, CSI, Flash memory in normal mode	68	75	
		VOS5, CSI, Flash memory in low-power mode	68	77	
$t_{WUSTOP\_KERON}^{(2)}$	Wakeup from Stop, clock kept running	VOS3, HSI, Flash memory in normal mode	2.6	3.4	$\mu\text{s}$
		VOS3, CSI, Flash memory in normal mode	26	36	
$t_{WUSTDBY}^{(2)}$	Wakeup from Standby mode	-	390	500	$\mu\text{s}$

1. Guaranteed by characterization results.

2. The wakeup times are measured from the wakeup event to the point in which the application code reads the first instruction.

### 7.3.8 External clock source characteristics

#### High-speed external user clock generated from an external source

In bypass mode the HSE oscillator is switched off and the input pin is a standard I/O.

The external clock signal has to respect the [Table 155: I/O static characteristics](#). However, the recommended clock input waveform is shown in [Figure 67](#).

**Table 137. High-speed external user clock characteristics<sup>(1)</sup>**

Symbol	Parameter	Min	Typ	Max	Unit
$f_{HSE\_ext}$	User external clock source frequency	4	25	50	MHz
$V_{SW}$ ( $V_{HSEH}$ ? $V_{HSEL}$ )	OSC_IN amplitude	$0.7V_{DD}$	-	$V_{DD}$	V
$V_{DC}$	OSC_IN input voltage	$V_{SS}$	-	$0.3V_{SS}$	
$t_{W(HSE)}$	OSC_IN high or low time	7	-	-	ns

1. Guaranteed by design.

**Figure 67. High-speed external clock source AC timing diagram**

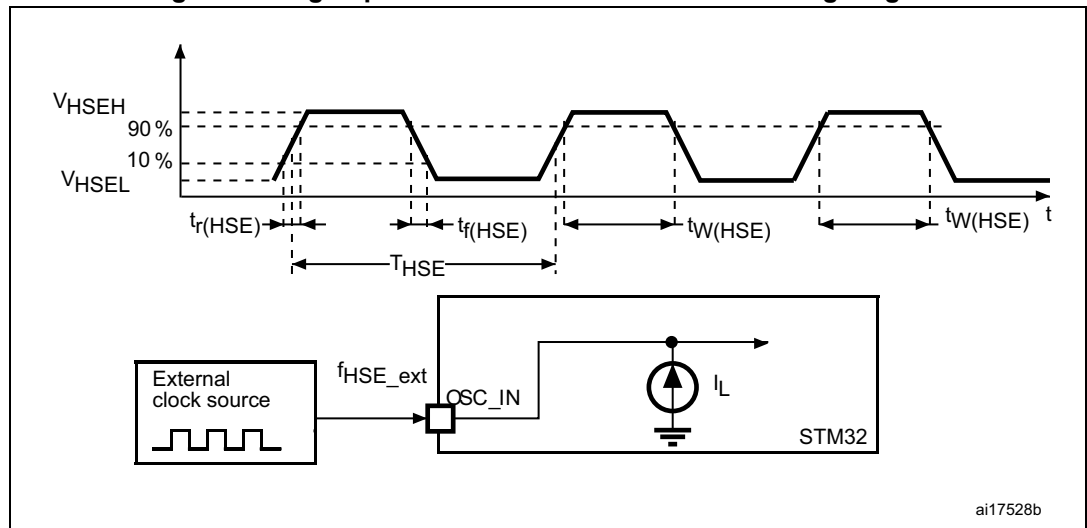

**Low-speed external user clock generated from an external source**

In bypass mode the LSE oscillator is switched off and the input pin is a standard I/O. The external clock signal has to respect the [Table 155: I/O static characteristics](#). However, the recommended clock input waveform is shown in [Figure 68](#).

**Table 138. Low-speed external user clock characteristics<sup>(1)</sup>**

Symbol	Parameter	Conditions	Min	Typ	Max	Unit
$f_{LSE\_ext}$	User external clock source frequency	-	-	32.768	1000	kHz
$V_{LSEH}$	OSC32_IN input pin high level voltage	-	$0.7 V_{DDIOx}$	-	$V_{DDIOx}$	V
$V_{LSEL}$	OSC32_IN input pin low level voltage	-	$V_{SS}$	-	$0.3 V_{DDIOx}$	
$t_{w(LSEH)}$ $t_{w(LSEL)}$	OSC32_IN high or low time	-	250	-	-	ns

1. Guaranteed by design.

**Note:** For information on selecting the crystal, refer to the application note AN2867 “Oscillator design guide for ST microcontrollers” available from the ST website [www.st.com](http://www.st.com).

**Figure 68. Low-speed external clock source AC timing diagram**

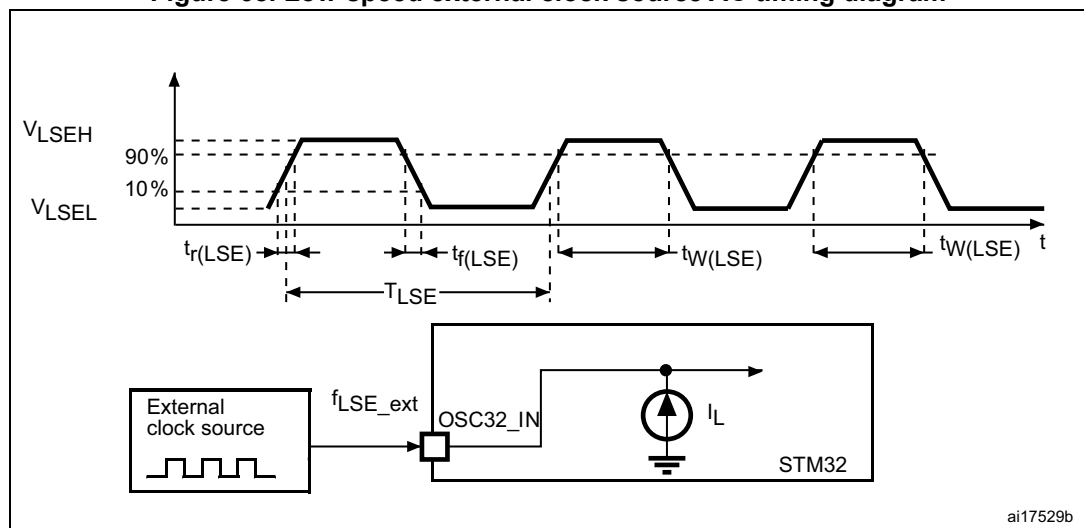

### High-speed external clock generated from a crystal/ceramic resonator

The high-speed external (HSE) clock can be supplied with a 4 to 48 MHz crystal/ceramic resonator oscillator. All the information given in this paragraph are based on characterization results obtained with typical external components specified in [Table 139](#). In the application, the resonator and the load capacitors have to be placed as close as possible to the oscillator pins in order to minimize output distortion and startup stabilization time. Refer to the crystal resonator manufacturer for more details on the resonator characteristics (frequency, package, accuracy).

**Table 139. 4-48 MHz HSE oscillator characteristics<sup>(1)</sup>**

Symbol	Parameter	Operating conditions <sup>(2)</sup>	Min	Typ	Max	Unit
F	Oscillator frequency	-	4	-	48	MHz
R <sub>F</sub>	Feedback resistor	-	-	200	-	kΩ
I <sub>DD(HSE)</sub>	HSE current consumption	During startup <sup>(3)</sup>	-	-	4	mA
		V <sub>DD</sub> =3 V, R <sub>m</sub> =30 Ω C <sub>L</sub> =10pF@4MHz	-	0.35	-	
		V <sub>DD</sub> =3 V, R <sub>m</sub> =30 Ω C <sub>L</sub> =10 pF at 8 MHz	-	0.40	-	
		V <sub>DD</sub> =3 V, R <sub>m</sub> =30 Ω C <sub>L</sub> =10 pF at 16 MHz	-	0.45	-	
		V <sub>DD</sub> =3 V, R <sub>m</sub> =30 Ω C <sub>L</sub> =10 pF at 32 MHz	-	0.65	-	
		V <sub>DD</sub> =3 V, R <sub>m</sub> =30 Ω C <sub>L</sub> =10 pF at 48 MHz	-	0.95	-	
G <sub>m<sub>crit</sub>max</sub>	Maximum critical crystal gm	Startup	-	-	1.5	mA/V
t <sub>SU</sub> <sup>(4)</sup>	Start-up time	V <sub>DD</sub> is stabilized	-	2	-	ms

1. Guaranteed by design.
2. Resonator characteristics given by the crystal/ceramic resonator manufacturer.
3. This consumption level occurs during the first 2/3 of the t<sub>SU(HSE)</sub> startup time.
4. t<sub>SU(HSE)</sub> is the startup time measured from the moment it is enabled (by software) to a stabilized 8 MHz oscillation is reached. This value is measured for a standard crystal resonator and it can vary significantly with the crystal manufacturer.

For C<sub>L1</sub> and C<sub>L2</sub>, it is recommended to use high-quality external ceramic capacitors in the 5 pF to 25 pF range (typical), designed for high-frequency applications, and selected to match the requirements of the crystal or resonator (see [Figure 69](#)). C<sub>L1</sub> and C<sub>L2</sub> are usually the same size. The crystal manufacturer typically specifies a load capacitance which is the series combination of C<sub>L1</sub> and C<sub>L2</sub>. The PCB and MCU pin capacitance must be included (10 pF can be used as a rough estimate of the combined pin and board capacitance) when sizing C<sub>L1</sub> and C<sub>L2</sub>.

**Note:** For information on selecting the crystal, refer to the application note AN2867 "Oscillator design guide for ST microcontrollers" available from the ST website [www.st.com](http://www.st.com).



Figure 69. Typical application with an 8 MHz crystal

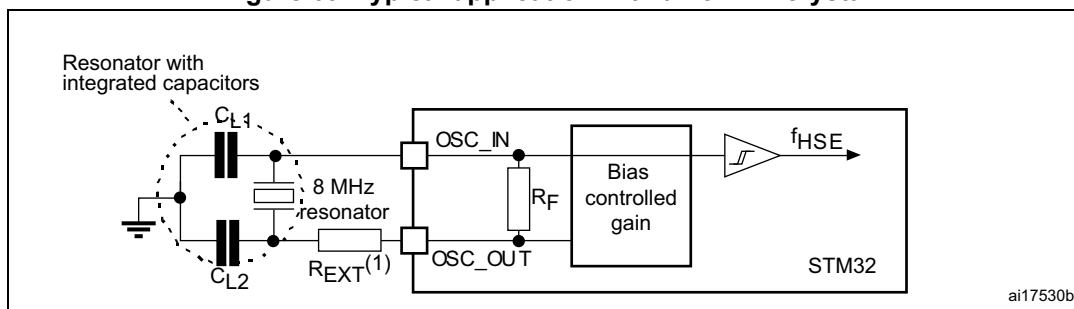

1.  $R_{EXT}$  value depends on the crystal characteristics.

### Low-speed external clock generated from a crystal/ceramic resonator

The low-speed external (LSE) clock can be supplied with a 32.768 kHz crystal/ceramic resonator oscillator. All the information given in this paragraph are based on characterization results obtained with typical external components specified in [Table 140](#). In the application, the resonator and the load capacitors have to be placed as close as possible to the oscillator pins in order to minimize output distortion and startup stabilization time. Refer to the crystal resonator manufacturer for more details on the resonator characteristics (frequency, package, accuracy).

Table 140. Low-speed external user clock characteristics<sup>(1)</sup>

Symbol	Parameter	Operating conditions <sup>(2)</sup>	Min	Typ	Max	Unit
F	Oscillator frequency	-	-	32.768	-	kHz
$I_{DD}$	LSE current consumption	LSEDRV[1:0] = 00, Low drive capability	-	290	-	nA
		LSEDRV[1:0] = 01, Medium Low drive capability	-	390	-	
		LSEDRV[1:0] = 10, Medium high drive capability	-	550	-	
		LSEDRV[1:0] = 11, High drive capability	-	900	-	
$G_{m_{critmax}}$	Maximum critical crystal gm	LSEDRV[1:0] = 00, Low drive capability	-	-	0.5	$\mu A/V$
		LSEDRV[1:0] = 01, Medium Low drive capability	-	-	0.75	
		LSEDRV[1:0] = 10, Medium high drive capability	-	-	1.7	
		LSEDRV[1:0] = 11, High drive capability	-	-	2.7	
$t_{SU}^{(3)}$	Startup time	VDD is stabilized	-	2	-	s

1. Guaranteed by design.
2. Refer to the note and caution paragraphs below the table, and to the application note AN2867 "Oscillator design guide for ST microcontrollers.
3.  $t_{SU}$  is the startup time measured from the moment it is enabled (by software) to a stabilized 32.768k Hz oscillation is reached. This value is measured for a standard crystal resonator and it can vary significantly with the crystal manufacturer.

Note: For information on selecting the crystal, refer to the application note AN2867 "Oscillator design guide for ST microcontrollers" available from the ST website [www.st.com](http://www.st.com).

Figure 70. Typical application with a 32.768 kHz crystal

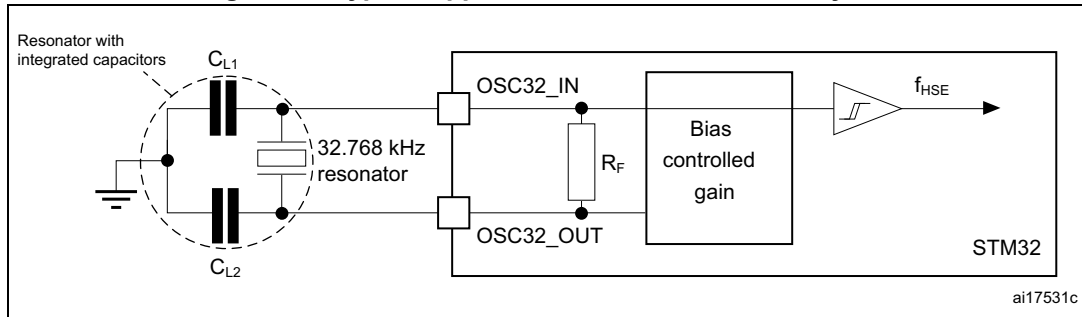

1. An external resistor is not required between OSC32\_IN and OSC32\_OUT and it is forbidden to add one.

### 7.3.9 Internal clock source characteristics

The parameters given in [Table 141](#) to [Table 144](#) are derived from tests performed under ambient temperature and  $V_{DD}$  supply voltage conditions summarized in [Table 120: General operating conditions](#).

#### 48 MHz high-speed internal RC oscillator (HSI48)

Table 141. HSI48 oscillator characteristics

Symbol	Parameter	Conditions	Min	Typ	Max	Unit
$f_{\text{HSI48}}$	HSI48 frequency	$V_{DD}=3.3\text{ V}$ , $T_J=30\text{ }^\circ\text{C}$	47.5 <sup>(1)</sup>	48	48.5 <sup>(1)</sup>	MHz
TRIM <sup>(2)</sup>	USER trimming step	-	-	0.175	-	%
USER TRIM COVERAGE <sup>(3)</sup>	USER TRIMMING Coverage	$\pm 32$ steps	$\pm 4.79$	$\pm 5.60$	-	%
DuCy(HSI48) <sup>(2)</sup>	Duty Cycle	-	45	-	55	%
ACCHSI48_REL <sup>(3)(4)</sup>	Accuracy of the HSI48 oscillator over temperature (factory calibrated)	$T_J=-40$ to $125\text{ }^\circ\text{C}$	-4.5	-	3.5	%
$\Delta V_{DD}(\text{HSI48})$ <sup>(3)</sup>	HSI48 oscillator frequency drift with $V_{DD}$ <sup>(5)</sup>	$V_{DD}=3$ to $3.6\text{ V}$	-	0.025	0.05	%
		$V_{DD}=1.62\text{ V}$ to $3.6\text{ V}$	-	0.05	0.1	
$t_{\text{su}}(\text{HSI48})$ <sup>(2)</sup>	HSI48 oscillator start-up time	-	-	2.1	4.0	$\mu\text{s}$
$I_{DD}(\text{HSI48})$ <sup>(2)</sup>	HSI48 oscillator power consumption	-	-	350	400	$\mu\text{A}$
$N_T$ jitter	Next transition jitter Accumulated jitter on 28 cycles <sup>(6)</sup>	-	-	$\pm 0.15$	-	ns
$P_T$ jitter	Paired transition jitter Accumulated jitter on 56 cycles <sup>(6)</sup>	-	-	$\pm 0.25$	-	ns

1. Guaranteed by test in production.
2. Guaranteed by design.
3. Guaranteed by characterization.
4.  $\Delta f_{\text{HSI}} = \text{ACCHSI48\_REL} + \Delta V_{DD}$ .

5. These values are obtained by using the formula:  $(\text{Freq}(3.6\text{V}) - \text{Freq}(3.0\text{V})) / \text{Freq}(3.0\text{V})$  or  $(\text{Freq}(3.6\text{V}) - \text{Freq}(1.62\text{V})) / \text{Freq}(1.62\text{V})$ .
6. Jitter measurements are performed without clock source activated in parallel.

### 64 MHz high-speed internal RC oscillator (HSI)

Table 142. HSI oscillator characteristics<sup>(1)</sup>

Symbol	Parameter	Conditions	Min	Typ	Max	Unit
$f_{\text{HSI}}$	HSI frequency	$V_{\text{DD}}=3.3\text{ V}, T_{\text{J}}=30\text{ }^{\circ}\text{C}$	63.7 <sup>(2)</sup>	64	64.3 <sup>(2)</sup>	MHz
TRIM	HSI user trimming step	Trimming is not a multiple of 32	-	0.24	0.32	%
		Trimming is 128, 256 and 384	-5.2	-1.8	-	
		Trimming is 64, 192, 320 and 448	-1.4	-0.8	-	
		Other trimming are a multiple of 32 (not including multiple of 64 and 128)	-0.6	-0.25	-	
DuCy(HSI)	Duty Cycle	-	45	-	55	%
$\Delta V_{\text{DD}}(\text{HSI})$	HSI oscillator frequency drift over $V_{\text{DD}}$ (reference is 3.3 V)	$V_{\text{DD}}=1.62\text{ to }3.6\text{ V}$	-0.12	-	0.03	%
$\Delta T_{\text{EMP}}(\text{HSI})$	HSI oscillator frequency drift over temperature (reference is 64 MHz)	$T_{\text{J}}=-20\text{ to }105\text{ }^{\circ}\text{C}$	-1 <sup>(3)</sup>	-	1 <sup>(3)</sup>	%
		$T_{\text{J}}=-40\text{ to }T_{\text{Jmax}}\text{ }^{\circ}\text{C}$	-2 <sup>(3)</sup>	-	1 <sup>(3)</sup>	
$t_{\text{su}}(\text{HSI})$	HSI oscillator start-up time	-	-	1.4	2	$\mu\text{s}$
$t_{\text{stab}}(\text{HSI})$	HSI oscillator stabilization time	at 1% of target frequency	-	4	8	$\mu\text{s}$
$I_{\text{DD}}(\text{HSI})$	HSI oscillator power consumption	-	-	300	400	$\mu\text{A}$

1. Guaranteed by design unless otherwise specified.
2. Guaranteed by test in production.
3. Guaranteed by characterization.

### 4 MHz low-power internal RC oscillator (CSI)

Table 143. CSI oscillator characteristics<sup>(1)</sup>

Symbol	Parameter	Conditions	Min	Typ	Max	Unit
$f_{\text{CSI}}$	CSI frequency	$V_{\text{DD}}=3.3\text{ V}, T_{\text{J}}=30\text{ }^{\circ}\text{C}$	3.96 <sup>(2)</sup>	4	4.04 <sup>(2)</sup>	MHz
TRIM	Trimming step	-	-	0.35	-	%
DuCy(CSI)	Duty Cycle	-	45	-	55	%
$\Delta T_{\text{EMP}}(\text{CSI})$	CSI oscillator frequency drift over temperature	$T_{\text{J}}=0\text{ to }85\text{ }^{\circ}\text{C}$	-	-3.7 <sup>(3)</sup>	4.5 <sup>(3)</sup>	%
		$T_{\text{J}}=-40\text{ to }125\text{ }^{\circ}\text{C}$	-	-11 <sup>(3)</sup>	7.5 <sup>(3)</sup>	
$D_{\text{VDD}}(\text{CSI})$	CSI oscillator frequency drift over $V_{\text{DD}}$	$V_{\text{DD}}=1.62\text{ to }3.6\text{ V}$	-	-0.06	0.06	%

Table 143. CSI oscillator characteristics<sup>(1)</sup> (continued)

Symbol	Parameter	Conditions	Min	Typ	Max	Unit
$t_{su(CSI)}$	CSI oscillator startup time	-	-	1	2	$\mu s$
$t_{stab(CSI)}$	CSI oscillator stabilization time (to reach $\pm 3\%$ of $f_{CSI}$ )	-	-	-	4	cycle
$I_{DD(CSI)}$	CSI oscillator power consumption	-	-	23	30	$\mu A$

1. Guaranteed by design.
2. Guaranteed by test in production.
3. Guaranteed by characterization.

### Low-speed internal (LSI) RC oscillator

Table 144. LSI oscillator characteristics

Symbol	Parameter	Conditions	Min	Typ	Max	Unit
$f_{LSI}$	LSI frequency	$V_{DD} = 3.3 V, T_J = 25\text{ }^\circ C$	31.4 <sup>(1)</sup>	32	32.6 <sup>(1)</sup>	kHz
		$T_J = -40\text{ to }110\text{ }^\circ C, V_{DD} = 1.62\text{ to }3.6\text{ V}$	29.76 <sup>(2)</sup>	-	33.6 <sup>(2)</sup>	
		$T_J = -40\text{ to }125\text{ }^\circ C, V_{DD} = 1.62\text{ to }3.6\text{ V}$	29.4	-	33.6	
$t_{su(LSI)}^{(3)}$	LSI oscillator startup time	-	-	80	130	$\mu s$
$t_{stab(LSI)}^{(3)}$	LSI oscillator stabilization time (5% of final value)	-	-	120	170	
$I_{DD(LSI)}^{(3)}$	LSI oscillator power consumption	-	-	130	280	

1. Guaranteed by test in production.
2. Guaranteed by characterization results.
3. Guaranteed by design.

### 7.3.10 PLL characteristics

The parameters given in [Table 145](#) are derived from tests performed under temperature and  $V_{DD}$  supply voltage conditions summarized in [Table 120: General operating conditions](#).

**Table 145. PLL characteristics (wide VCO frequency range)<sup>(1)</sup>**

Symbol	Parameter	Conditions	Min	Typ	Max	Unit		
$f_{PLL\_IN}$	PLL input clock	-	2	-	16	MHz		
	PLL input clock duty cycle	-	10	-	90	%		
$f_{PLL\_P\_OUT}$	PLL multiplier output clock P	VOS0	1.5	-	480 <sup>(2)</sup>	MHz		
		VOS1	1.5	-	400 <sup>(2)</sup>			
		VOS2	1.5	-	300 <sup>(2)</sup>			
		VOS3	1.5	-	200 <sup>(2)</sup>			
$f_{VCO\_OUT}$	PLL VCO output	-	192	-	960			
$t_{LOCK}$	PLL lock time	Normal mode	-	50 <sup>(3)</sup>	150 <sup>(3)</sup>	$\mu s$		
		Sigma-delta mode (CKIN $\geq$ 8 MHz)	-	58 <sup>(3)</sup>	166 <sup>(3)</sup>			
Jitter	Cycle-to-cycle jitter <sup>(4)</sup>	-	VCO = 192 MHz	-	134	-	$\pm ps$	
			VCO = 200 MHz	-	134	-		
			VCO = 400 MHz	-	76	-		
			VCO = 800 MHz	-	39	-		
	Long term jitter	Normal mode	VCO = 800 MHz	-	$\pm 0.7$	-	%	
			Sigma-delta mode (CKIN = 16 MHz)	VCO = 800 MHz	-	$\pm 0.8$		-
	$I_{DD(PLL)}^{(3)}$	PLL power consumption on $V_{DD}$	VCO freq = 836 MHz	$V_{DDA}$	-	590	1500	$\mu A$
				$V_{CORE}$	-	720	-	
VCO freq = 192 MHz			$V_{DDA}$	-	180	600		
			$V_{CORE}$	-	280	-		

1. Guaranteed by design unless otherwise specified.
2. This value must be limited to the maximum frequency due to the product limitation (480 MHz for VOS0, 400 MHz for VOS1, 300 MHz for VOS2, 200 MHz for VOS3).
3. Guaranteed by characterization results.
4. Integer mode only.

Table 146. PLL characteristics (medium VCO frequency range)<sup>(1)</sup>

Symbol	Parameter	Conditions	Min	Typ	Max	Unit	
$f_{\text{PLL\_IN}}$	PLL input clock	-	1	-	2	MHz	
	PLL input clock duty cycle	-	10	-	90	%	
$f_{\text{PLL\_OUT}}$	PLL multiplier output clock P, Q, R	VOS1	1.17	-	210	MHz	
		VOS2	1.17	-	210		
		VOS3	1.17	-	200		
$f_{\text{VCO\_OUT}}$	PLL VCO output	-	150	-	420		
$t_{\text{LOCK}}$	PLL lock time	Normal mode	-	60 <sup>(2)</sup>	100 <sup>(2)</sup>	$\mu\text{s}$	
		Sigma-delta mode	forbidden				
Jitter	Cycle-to-cycle jitter <sup>(3)</sup>	-	VCO = 150 MHz	-	145	-	$\pm\text{ps}$
			VCO = 300 MHz	-	91	-	
			VCO = 400 MHz	-	64	-	
			VCO = 420 MHz	-	63	-	
	Period jitter	$f_{\text{PLL\_OUT}} = 50 \text{ MHz}$	VCO = 150 MHz	-	55	-	$\pm\text{-ps}$
			VCO = 400 MHz	-	30	-	
Long term jitter	Normal mode	VCO = 400 MHz	-	$\pm 0.3$	-	%	
$I(\text{PLL})^{(2)}$	PLL power consumption on $V_{\text{DD}}$	VCO freq = 420MHz	VDD	-	440	1150	$\mu\text{A}$
			VCORE	-	530	-	
		VCO freq = 150MHz	VDD	-	180	500	
			VCORE	-	200	-	

1. Guaranteed by design unless otherwise specified.

2. Guaranteed by characterization results.

3. Integer mode only.

### 7.3.11 Memory characteristics

#### Flash memory

The characteristics are given at  $T_J = -40$  to  $125$  °C unless otherwise specified.

The devices are shipped to customers with the Flash memory erased.

**Table 147. Flash memory characteristics**

Symbol	Parameter	Conditions	Min	Typ	Max	Unit
$I_{DD}$	Supply current	Write / Erase 8-bit mode	-	6.5	-	mA
		Write / Erase 16-bit mode	-	11.5	-	
		Write / Erase 32-bit mode	-	20	-	
		Write / Erase 64-bit mode	-	35	-	

**Table 148. Flash memory programming**

Symbol	Parameter	Conditions	Min <sup>(1)</sup>	Typ	Max <sup>(1)</sup>	Unit
$t_{prog}$	Word (266 bits) programming time	Program/erase parallelism x 8	-	290	580 <sup>(2)</sup>	$\mu$ s
		Program/erase parallelism x 16	-	180	360	
		Program/erase parallelism x 32	-	130	260	
		Program/erase parallelism x 64	-	100	200	
$t_{ERASE128KB}$	Sector (128 KB) erase time	Program/erase parallelism x 8	-	2	4	s
		Program/erase parallelism x 16	-	1.8	3.6	
		Program/erase parallelism x 32	-			
$t_{ME}$	Mass erase time	Program/erase parallelism x 8	-	13	26	s
		Program/erase parallelism x 16	-	8	16	
		Program/erase parallelism x 32	-	6	12	
		Program/erase parallelism x 64	-	5	10	
$V_{prog}$	Programming voltage	Program parallelism x 8	1.62	-	3.6	V
		Program parallelism x 16				
		Program parallelism x 32				
		Program parallelism x 64	1.8	-	3.6	

1. Guaranteed by characterization results.

2. The maximum programming time is measured after 10K erase operations.

Table 149. Flash memory endurance and data retention

Symbol	Parameter	Conditions	Value	Unit
			Min <sup>(1)</sup>	
N <sub>END</sub>	Endurance	T <sub>J</sub> = -40 to +125 °C (6 suffix versions)	10	kcycles
t <sub>RET</sub>	Data retention	1 kcycle at T <sub>A</sub> = 85 °C	30	Years
		10 kcycles at T <sub>A</sub> = 55 °C	20	

1. Guaranteed by characterization results.

### 7.3.12 EMC characteristics

Susceptibility tests are performed on a sample basis during device characterization.

#### Functional EMS (electromagnetic susceptibility)

While a simple application is executed on the device (toggling 2 LEDs through I/O ports), the device is stressed by two electromagnetic events until a failure occurs. The failure is indicated by the LEDs:

- **Electrostatic discharge (ESD)** (positive and negative) is applied to all device pins until a functional disturbance occurs. This test is compliant with the IEC 61000-4-2 standard.
- **FTB:** A burst of fast transient voltage (positive and negative) is applied to V<sub>DD</sub> and V<sub>SS</sub> through a 100 pF capacitor, until a functional disturbance occurs. This test is compliant with the IEC 61000-4-4 standard.

A device reset allows normal operations to be resumed.

The test results are given in [Table 150](#). They are based on the EMS levels and classes defined in application note AN1709.

Table 150. EMS characteristics

Symbol	Parameter	Conditions	Level/Class
V <sub>FESD</sub>	Voltage limits to be applied on any I/O pin to induce a functional disturbance	V <sub>DD</sub> = 3.3 V, T <sub>A</sub> = +25 °C, UFBGA240, f <sub>rcc_ck</sub> = 400 MHz, conforms to IEC 61000-4-2	3B
V <sub>FTB</sub>	Fast transient voltage burst limits to be applied through 100 pF on V <sub>DD</sub> and V <sub>SS</sub> pins to induce a functional disturbance		5A

As a consequence, it is recommended to add a serial resistor (1 k?) located as close as possible to the MCU to the pins exposed to noise (connected to tracks longer than 50 mm on PCB).



**Designing hardened software to avoid noise problems**

EMC characterization and optimization are performed at component level with a typical application environment and simplified MCU software. It should be noted that good EMC performance is highly dependent on the user application and the software in particular.

Therefore it is recommended that the user applies EMC software optimization and prequalification tests in relation with the EMC level requested for his application.

**Software recommendations**

The software flowchart must include the management of runaway conditions such as:

- Corrupted program counter
- Unexpected reset
- Critical Data corruption (control registers...)

**Prequalification trials**

Most of the common failures (unexpected reset and program counter corruption) can be reproduced by manually forcing a low state on the NRST pin or the Oscillator pins for 1 second.

To complete these trials, ESD stress can be applied directly on the device, over the range of specification values. When unexpected behavior is detected, the software can be hardened to prevent unrecoverable errors occurring (see application note AN1015).

**Electromagnetic Interference (EMI)**

The electromagnetic field emitted by the device are monitored while a simple application, executing EEMBC code, is running. This emission test is compliant with SAE IEC61967-2 standard which specifies the test board and the pin loading.

**Table 151. EMI characteristics**

Symbol	Parameter	Conditions	Monitored frequency band	Max vs. [f <sub>HSE</sub> /f <sub>CPU</sub> ]	Unit
				8/400 MHz	
S <sub>EMI</sub>	Peak level	V <sub>DD</sub> = 3.6 V, T <sub>A</sub> = 25 °C, UFBGA240 package, conforming to IEC61967-2	0.1 to 30 MHz	11	dBμV
			30 to 130 MHz	6	
			130 MHz to 1 GHz	12	
			1 GHz to 2 GHz	7	
			EMI Level	2.5	-

### 7.3.13 Absolute maximum ratings (electrical sensitivity)

Based on three different tests (ESD, LU) using specific measurement methods, the device is stressed in order to determine its performance in terms of electrical sensitivity.

#### Electrostatic discharge (ESD)

Electrostatic discharges (a positive then a negative pulse) are applied to the pins of each sample according to each pin combination. This test conforms to the ANSI/ESDA/JEDEC JS-001 and ANSI/ESDA/JEDEC JS-002 standards.

**Table 152. ESD absolute maximum ratings**

Symbol	Ratings	Conditions	Packages	Class	Maximum value <sup>(1)</sup>	Unit
$V_{ESD(HBM)}$	Electrostatic discharge voltage (human body model)	$T_A = +25\text{ °C}$ conforming to ANSI/ESDA/JEDEC JS-001	All	1C	1000	V
$V_{ESD(CDM)}$	Electrostatic discharge voltage (charge device model)	$T_A = +25\text{ °C}$ conforming to ANSI/ESDA/JEDEC JS-002	All	C1	250	

1. Guaranteed by characterization results.

#### Static latchup

Two complementary static tests are required on six parts to assess the latchup performance:

- A supply overvoltage is applied to each power supply pin
- A current injection is applied to each input, output and configurable I/O pin

These tests are compliant with JESD78 IC latchup standard.

**Table 153. Electrical sensitivities**

Symbol	Parameter	Conditions	Class
LU	Static latchup class	$T_A = +25\text{ °C}$ conforming to JESD78	II level A

### 7.3.14 I/O current injection characteristics

As a general rule, a current injection to the I/O pins, due to external voltage below  $V_{SS}$  or above  $V_{DD}$  (for standard, 3.3 V-capable I/O pins) should be avoided during the normal product operation. However, in order to give an indication of the robustness of the microcontroller in cases when an abnormal injection accidentally happens, susceptibility tests are performed on a sample basis during the device characterization.

#### Functional susceptibility to I/O current injection

While a simple application is executed on the device, the device is stressed by injecting current into the I/O pins programmed in floating input mode. While current is injected into the I/O pin, one at a time, the device is checked for functional failures.

The failure is indicated by an out of range parameter: ADC error above a certain limit (higher than 5 LSB TUE), out of conventional limits of induced leakage current on adjacent pins (out of  $-5 \mu A/+0 \mu A$  range), or other functional failure (for example reset, oscillator frequency deviation).

The following tables are the compilation of the SIC1/SIC2 and functional ESD results.

Negative induced A negative induced leakage current is caused by negative injection and positive induced leakage current by positive injection.

**Table 154. I/O current injection susceptibility<sup>(1)</sup>**

Symbol	Description	Functional susceptibility		Unit
		Negative injection	Positive injection	
$I_{INJ}$	PA7, PC5, PG1, PB14, PJ7, PA11, PA12, PA13, PA14, PA15, PJ12, PB4	5	0	mA
	PA2, PH2, PH3, PE8, PA6, PA7, PC4, PE7, PE10, PE11	0	NA	
	PA0, PA_C, PA1, PA1_C, PC2, PC2_C, PC3, PC3_C, PA4, PA5, PH4, PH5, BOOT0	0	0	
	All other I/Os	5	NA	

1. Guaranteed by characterization.

### 7.3.15 I/O port characteristics

#### General input/output characteristics

Unless otherwise specified, the parameters given in [Table 155: I/O static characteristics](#) are derived from tests performed under the conditions summarized in [Table 120: General operating conditions](#). All I/Os are CMOS and TTL compliant (except for BOOT0).

**Table 155. I/O static characteristics**

Symbol	Parameter	Condition	Min	Typ	Max	Unit
$V_{IL}$	I/O input low level voltage except BOOT0	$1.62\text{ V} < V_{DDIOx} < 3.6\text{ V}$	-	-	$0.3V_{DD}^{(1)}$	V
	I/O input low level voltage except BOOT0		-	-	$0.4V_{DD} - 0.1^{(2)}$	
	BOOT0 I/O input low level voltage		-	-	$0.19V_{DD} + 0.1^{(2)}$	
$V_{IH}$	I/O input high level voltage except BOOT0	$1.62\text{ V} < V_{DDIOx} < 3.6\text{ V}$	$0.7V_{DD}^{(1)}$	-	-	V
	I/O input high level voltage except BOOT0 <sup>(3)</sup>		$0.47V_{DD} + 0.25^{(2)}$	-	-	
	BOOT0 I/O input high level voltage <sup>(3)</sup>		$0.17V_{DD} + 0.6^{(2)}$	-	-	
$V_{HYS}^{(2)}$	TT_xx, FT_XXX and NRST I/O input hysteresis	$1.62\text{ V} < V_{DDIOx} < 3.6\text{ V}$	-	250	-	mV
	BOOT0 I/O input hysteresis		-	200	-	
$I_{leak}^{(4)}$	FT_xx Input leakage current <sup>(2)</sup>	$0 < V_{IN} \leq \text{Max}(V_{DDXXX})^{(9)}$	-	-	+/-250	nA
		$\text{Max}(V_{DDXXX}) < V_{IN} \leq 5.5\text{ V}$ <sub>(5)(6)(9)</sub>	-	-	1500	
	FT_u IO	$0 < V_{IN} \leq \text{Max}(V_{DDXXX})^{(9)}$	-	-	+/- 350	
		$\text{Max}(V_{DDXXX}) < V_{IN} \leq 5.5\text{ V}$ <sub>(5)(6)(9)</sub>	-	-	5000 <sup>(7)</sup>	
	TT_xx Input leakage current	$0 < V_{IN} \leq \text{Max}(V_{DDXXX})^{(9)}$	-	-	+/-250	
	VPP (BOOT0 alternate function)	$0 < V_{IN} \leq V_{DDIOx}$	-	-	15	
$V_{DDIOx} < V_{IN} \leq 9\text{ V}$		-	-	35		
$R_{PU}$	Weak pull-up equivalent resistor <sup>(8)</sup>	$V_{IN} = V_{SS}$	30	40	50	kΩ
$R_{PD}$	Weak pull-down equivalent resistor <sup>(8)</sup>	$V_{IN} = V_{DD}^{(9)}$	30	40	50	
$C_{IO}$	I/O pin capacitance	-	-	5	-	pF

1. Compliant with CMOS requirements.

2. Guaranteed by design.

3. VDDIOx represents VDDIO1, VDDIO2 or VDDIO3. VDDIOx= VDD.

4. This parameter represents the pad leakage of the I/O itself. The total product pad leakage is provided by the following formula:  $I_{Total\_leak\_max} = 10\ \mu\text{A} + [\text{number of I/Os where } V_{IN} \text{ is applied on the pad}] \times I_{Ikg}(\text{Max})$ .

5. All FT\_xx IO except FT\_lu, FT\_u and PC3.

6.  $V_{IN}$  must be less than  $\text{Max}(V_{DDXXX}) + 3.6 \text{ V}$ .
7. To sustain a voltage higher than  $\text{MIN}(V_{DD}, V_{DDA}, V_{DD33USB}) + 0.3 \text{ V}$ , the internal pull-up and pull-down resistors must be disabled.
8. The pull-up and pull-down resistors are designed with a true resistance in series with a switchable PMOS/NMOS. This PMOS/NMOS contribution to the series resistance is minimal (~10% order).
9.  $\text{Max}(V_{DDXXX})$  is the maximum value of all the I/O supplies.

All I/Os are CMOS and TTL compliant (no software configuration required). Their characteristics cover more than the strict CMOS-technology or TTL parameters. The coverage of these requirements for FT I/Os is shown in [Figure 71](#).

**Figure 71.  $V_{IL}/V_{IH}$  for all I/Os except BOOT0**

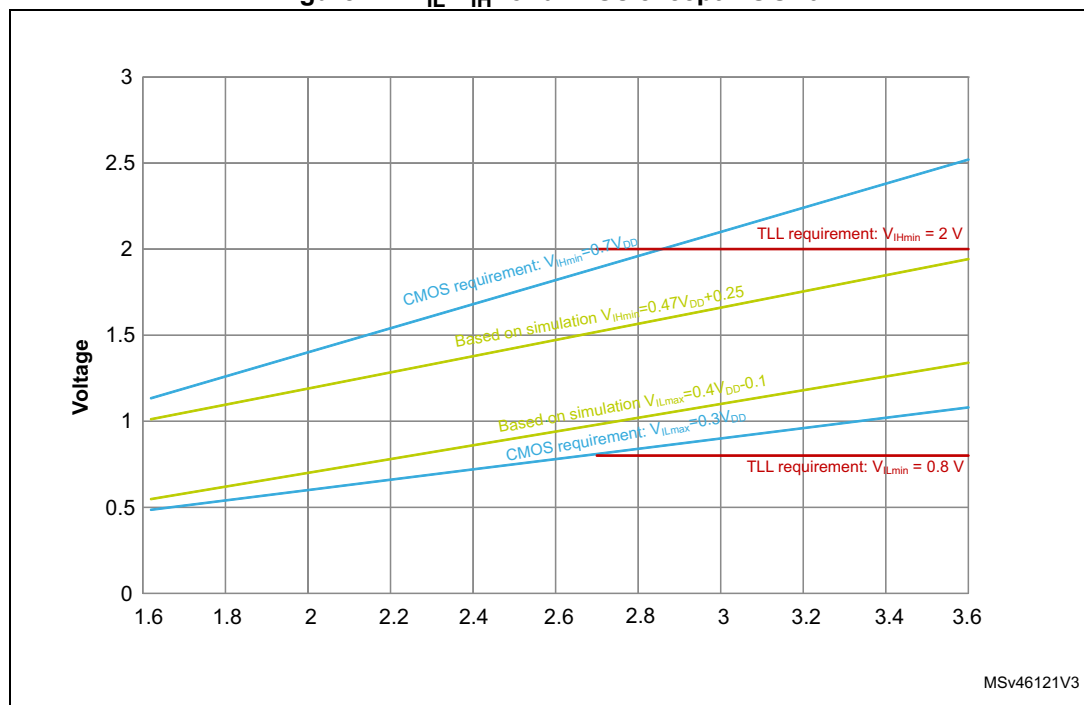

### Output driving current

The GPIOs (general purpose input/outputs) can sink or source up to  $\pm 8 \text{ mA}$ , and sink or source up to  $\pm 20 \text{ mA}$  (with a relaxed  $V_{OL}/V_{OH}$ ).

In the user application, the number of I/O pins which can drive current must be limited to respect the absolute maximum rating specified in [Section 7.2](#). In particular:

- The sum of the currents sourced by all the I/Os on  $V_{DD}$ , plus the maximum Run consumption of the MCU sourced on  $V_{DD}$ , cannot exceed the absolute maximum rating  $\Sigma I_{VDD}$  (see [Table 118](#)).
- The sum of the currents sunk by all the I/Os on  $V_{SS}$  plus the maximum Run consumption of the MCU sunk on  $V_{SS}$  cannot exceed the absolute maximum rating  $\Sigma I_{VSS}$  (see [Table 118](#)).

### Output voltage levels

Unless otherwise specified, the parameters given in [Table 156: Output voltage characteristics for all I/Os except PC13, PC14, PC15 and PI8](#) and [Table 157: Output voltage characteristics for PC13, PC14, PC15 and PI8](#) are derived from tests performed under ambient temperature and  $V_{DD}$  supply voltage conditions summarized in [Table 120: General operating conditions](#). All I/Os are CMOS and TTL compliant.

**Table 156. Output voltage characteristics for all I/Os except PC13, PC14, PC15 and PI8<sup>(1)</sup>**

Symbol	Parameter	Conditions <sup>(3)</sup>	Min	Max	Unit
$V_{OL}$	Output low level voltage	CMOS port <sup>(2)</sup> $I_{IO}=8\text{ mA}$ $2.7\text{ V} \leq V_{DD} \leq 3.6\text{ V}$	-	0.4	V
$V_{OH}$	Output high level voltage	CMOS port <sup>(2)</sup> $I_{IO}=-8\text{ mA}$ $2.7\text{ V} \leq V_{DD} \leq 3.6\text{ V}$	$V_{DD}-0.4$	-	
$V_{OL}^{(3)}$	Output low level voltage	TTL port <sup>(2)</sup> $I_{IO}=8\text{ mA}$ $2.7\text{ V} \leq V_{DD} \leq 3.6\text{ V}$	-	0.4	
$V_{OH}^{(3)}$	Output high level voltage	TTL port <sup>(2)</sup> $I_{IO}=-8\text{ mA}$ $2.7\text{ V} \leq V_{DD} \leq 3.6\text{ V}$	2.4	-	
$V_{OL}^{(3)}$	Output low level voltage	$I_{IO}=20\text{ mA}$ $2.7\text{ V} \leq V_{DD} \leq 3.6\text{ V}$	-	1.3	
$V_{OH}^{(3)}$	Output high level voltage	$I_{IO}=-20\text{ mA}$ $2.7\text{ V} \leq V_{DD} \leq 3.6\text{ V}$	$V_{DD}-1.3$	-	
$V_{OL}^{(3)}$	Output low level voltage	$I_{IO}=4\text{ mA}$ $1.62\text{ V} \leq V_{DD} \leq 3.6\text{ V}$	-	0.4	
$V_{OH}^{(3)}$	Output high level voltage	$I_{IO}=-4\text{ mA}$ $1.62\text{ V} \leq V_{DD} < 3.6\text{ V}$	$V_{DD}-0.4$	-	
$V_{OLFM+}^{(3)}$	Output low level voltage for an FTf I/O pin in FM+ mode	$I_{IO}=20\text{ mA}$ $2.3\text{ V} \leq V_{DD} \leq 3.6\text{ V}$	-	0.4	
		$I_{IO}=10\text{ mA}$ $1.62\text{ V} \leq V_{DD} \leq 3.6\text{ V}$	-	0.4	

- The I/O current sourced or sunk by the device must always respect the absolute maximum rating specified in [Table 117: Voltage characteristics](#), and the sum of the currents sourced or sunk by all the I/Os (I/O ports and control pins) must always respect the absolute maximum ratings  $\Sigma I_{IO}$ .
- TTL and CMOS outputs are compatible with JEDEC standards JESD36 and JESD52.
- Guaranteed by design.

Table 157. Output voltage characteristics for PC13, PC14, PC15 and PI8<sup>(1)</sup>

Symbol	Parameter	Conditions <sup>(3)</sup>	Min	Max	Unit
$V_{OL}$	Output low level voltage	CMOS port <sup>(2)</sup> $I_{IO}=3\text{ mA}$ $2.7\text{ V} \leq V_{DD} \leq 3.6\text{ V}$	-	0.4	V
$V_{OH}$	Output high level voltage	CMOS port <sup>(2)</sup> $I_{IO}=-3\text{ mA}$ $2.7\text{ V} \leq V_{DD} \leq 3.6\text{ V}$	$V_{DD}-0.4$	-	
$V_{OL}^{(3)}$	Output low level voltage	TTL port <sup>(2)</sup> $I_{IO}=3\text{ mA}$ $2.7\text{ V} \leq V_{DD} \leq 3.6\text{ V}$	-	0.4	
$V_{OH}^{(2)}$	Output high level voltage	TTL port <sup>(2)</sup> $I_{IO}=-3\text{ mA}$ $2.7\text{ V} \leq V_{DD} \leq 3.6\text{ V}$	2.4	-	
$V_{OL}^{(2)}$	Output low level voltage	$I_{IO}=1.5\text{ mA}$ $1.62\text{ V} \leq V_{DD} \leq 3.6\text{ V}$	-	0.4	
$V_{OH}^{(2)}$	Output high level voltage	$I_{IO}=-1.5\text{ mA}$ $1.62\text{ V} \leq V_{DD} \leq 3.6\text{ V}$	$V_{DD}-0.4$	-	

1. The I/O current sourced or sunk by the device must always respect the absolute maximum rating specified in [Table 117: Voltage characteristics](#), and the sum of the currents sourced or sunk by all the I/Os (I/O ports and control pins) must always respect the absolute maximum ratings  $\Sigma I/O$ .
2. TTL and CMOS outputs are compatible with JEDEC standards JESD36 and JESD52.
3. Guaranteed by design.

**Output buffer timing characteristics (HSLV option disabled)**

The HSLV bit of SYSCFG\_CCCSR register can be used to optimize the I/O speed when the product voltage is below 2.7 V.

**Table 158. Output timing characteristics (HSLV OFF)<sup>(1)(2)</sup>**

Speed	Symbol	Parameter	conditions	Min	Max	Unit
00	$F_{\max}^{(3)}$	Maximum frequency	C=50 pF, 2.7 V ≤ V <sub>DD</sub> ≤ 3.6 V	-	12	MHz
			C=50 pF, 1.62 V ≤ V <sub>DD</sub> ≤ 2.7 V	-	3	
			C=30 pF, 2.7 V ≤ V <sub>DD</sub> ≤ 3.6 V	-	12	
			C=30 pF, 1.62 V ≤ V <sub>DD</sub> ≤ 2.7 V	-	3	
			C=10 pF, 2.7 V ≤ V <sub>DD</sub> ≤ 3.6 V	-	16	
			C=10 pF, 1.62 V ≤ V <sub>DD</sub> ≤ 2.7 V	-	4	
	$t_r/t_f^{(4)}$	Output high to low level fall time and output low to high level rise time	C=50 pF, 2.7 V ≤ V <sub>DD</sub> ≤ 3.6 V	-	16.6	ns
			C=50 pF, 1.62 V ≤ V <sub>DD</sub> ≤ 2.7 V	-	33.3	
			C=30 pF, 2.7 V ≤ V <sub>DD</sub> ≤ 3.6 V	-	13.3	
			C=30 pF, 1.62 V ≤ V <sub>DD</sub> ≤ 2.7 V	-	25	
			C=10 pF, 2.7 V ≤ V <sub>DD</sub> ≤ 3.6 V	-	10	
			C=10 pF, 1.62 V ≤ V <sub>DD</sub> ≤ 2.7 V	-	20	
01	$F_{\max}^{(3)}$	Maximum frequency	C=50 pF, 2.7 V ≤ V <sub>DD</sub> ≤ 3.6 V	-	60	MHz
			C=50 pF, 1.62 V ≤ V <sub>DD</sub> ≤ 2.7 V	-	15	
			C=30 pF, 2.7 V ≤ V <sub>DD</sub> ≤ 3.6 V	-	80	
			C=30 pF, 1.62 V ≤ V <sub>DD</sub> ≤ 2.7 V	-	15	
			C=10 pF, 2.7 V ≤ V <sub>DD</sub> ≤ 3.6 V	-	110	
			C=10 pF, 1.62 V ≤ V <sub>DD</sub> ≤ 2.7 V	-	20	
	$t_r/t_f^{(4)}$	Output high to low level fall time and output low to high level rise time	C=50 pF, 2.7 V ≤ V <sub>DD</sub> ≤ 3.6 V	-	5.2	ns
			C=50 pF, 1.62 V ≤ V <sub>DD</sub> ≤ 2.7 V	-	10	
			C=30 pF, 2.7 V ≤ V <sub>DD</sub> ≤ 3.6 V	-	4.2	
			C=30 pF, 1.62 V ≤ V <sub>DD</sub> ≤ 2.7 V	-	7.5	
			C=10 pF, 2.7 V ≤ V <sub>DD</sub> ≤ 3.6 V	-	2.8	
			C=10 pF, 1.62 V ≤ V <sub>DD</sub> ≤ 2.7 V	-	5.2	



Table 158. Output timing characteristics (HSLV OFF)<sup>(1)(2)</sup> (continued)

Speed	Symbol	Parameter	conditions	Min	Max	Unit
10	$F_{\max}^{(3)}$	Maximum frequency	C=50 pF, 2.7 V ≤ V <sub>DD</sub> ≤ 3.6 V <sup>(5)</sup>	-	85	MHz
			C=50 pF, 1.62 V ≤ V <sub>DD</sub> ≤ 2.7 V <sup>(5)</sup>	-	35	
			C=30 pF, 2.7 V ≤ V <sub>DD</sub> ≤ 3.6 V <sup>(5)</sup>	-	110	
			C=30 pF, 1.62 V ≤ V <sub>DD</sub> ≤ 2.7 V <sup>(5)</sup>	-	40	
			C=10 pF, 2.7 V ≤ V <sub>DD</sub> ≤ 3.6 V <sup>(5)</sup>	-	166	
			C=10 pF, 1.62 V ≤ V <sub>DD</sub> ≤ 2.7 V <sup>(5)</sup>	-	100	
	$t_r/t_f^{(4)}$	Output high to low level fall time and output low to high level rise time	C=50 pF, 2.7 V ≤ V <sub>DD</sub> ≤ 3.6 V <sup>(5)</sup>	-	3.8	ns
			C=50 pF, 1.62 V ≤ V <sub>DD</sub> ≤ 2.7 V <sup>(5)</sup>	-	6.9	
			C=30 pF, 2.7 V ≤ V <sub>DD</sub> ≤ 3.6 V <sup>(5)</sup>	-	2.8	
			C=30 pF, 1.62 V ≤ V <sub>DD</sub> ≤ 2.7 V <sup>(5)</sup>	-	5.2	
11	$F_{\max}^{(3)}$	Maximum frequency	C=50 pF, 2.7 V ≤ V <sub>DD</sub> ≤ 3.6 V <sup>V</sup>	-	100	MHz
			C=50 pF, 1.62 V ≤ V <sub>DD</sub> ≤ 2.7 V <sup>(5)</sup>	-	50	
			C=30 pF, 2.7 V ≤ V <sub>DD</sub> ≤ 3.6 V <sup>V</sup>	-	133	
			C=30 pF, 1.62 V ≤ V <sub>DD</sub> ≤ 2.7 V <sup>(5)</sup>	-	66	
			C=10 pF, 2.7 V ≤ V <sub>DD</sub> ≤ 3.6 V <sup>(5)</sup>	-	220	
			C=10 pF, 1.62 V ≤ V <sub>DD</sub> ≤ 2.7 V <sup>(5)</sup>	-	85	
	$t_r/t_f^{(4)}$	Output high to low level fall time and output low to high level rise time	C=50 pF, 2.7 V ≤ V <sub>DD</sub> ≤ 3.6 V <sup>(5)</sup>	-	3.3	ns
			C=50 pF, 1.62 V ≤ V <sub>DD</sub> ≤ 2.7 V <sup>(5)</sup>	-	6.6	
			C=30 pF, 2.7 V ≤ V <sub>DD</sub> ≤ 3.6 V <sup>(5)</sup>	-	2.4	
			C=30 pF, 1.62 V ≤ V <sub>DD</sub> ≤ 2.7 V <sup>(5)</sup>	-	4.5	
			C=10 pF, 2.7 V ≤ V <sub>DD</sub> ≤ 3.6 V <sup>(5)</sup>	-	1.5	
			C=10 pF, 1.62 V ≤ V <sub>DD</sub> ≤ 2.7 V <sup>(5)</sup>	-	2.7	

- Guaranteed by design.
- The frequency of the GPIOs that can be supplied in V<sub>BAT</sub> mode (PC13, PC14, PC15 and PI8) is limited to 2 MHz
- The maximum frequency is defined with the following conditions:  
 $(t_r + t_f) \leq 2/3 T$   
Skew ≤ 1/20 T  
45% < Duty cycle < 55%
- The fall and rise times are defined between 90% and 10% and between 10% and 90% of the output waveform, respectively.
- Compensation system enabled.

## Output buffer timing characteristics (HSLV option enabled)

Table 159. Output timing characteristics (HSLV ON)<sup>(1)</sup>

Speed	Symbol	Parameter	conditions	Min	Max	Unit
00	$F_{\max}^{(2)}$	Maximum frequency	C=50 pF, 1.62 V ≤ V <sub>DD</sub> ≤ 2.7 V	-	10	MHz
			C=30 pF, 1.62 V ≤ V <sub>DD</sub> ≤ 2.7 V	-	10	
			C=10 pF, 1.62 V ≤ V <sub>DD</sub> ≤ 2.7 V	-	10	
	$t_r/t_f^{(3)}$	Output high to low level fall time and output low to high level rise time	C=50 pF, 1.62 V ≤ V <sub>DD</sub> ≤ 2.7 V	-	11	ns
			C=30 pF, 1.62 V ≤ V <sub>DD</sub> ≤ 2.7 V	-	9	
			C=10 pF, 1.62 V ≤ V <sub>DD</sub> ≤ 2.7 V	-	6.6	
01	$F_{\max}^{(2)}$	Maximum frequency	C=50 pF, 1.62 V ≤ V <sub>DD</sub> ≤ 2.7 V	-	50	MHz
			C=30 pF, 1.62 V ≤ V <sub>DD</sub> ≤ 2.7 V	-	58	
			C=10 pF, 1.62 V ≤ V <sub>DD</sub> ≤ 2.7 V	-	66	
	$t_r/t_f^{(3)}$	Output high to low level fall time and output low to high level rise time	C=50 pF, 1.62 V ≤ V <sub>DD</sub> ≤ 2.7 V	-	6.6	ns
			C=30 pF, 1.62 V ≤ V <sub>DD</sub> ≤ 2.7 V	-	4.8	
			C=10 pF, 1.62 V ≤ V <sub>DD</sub> ≤ 2.7 V	-	3	
10	$F_{\max}^{(2)}$	Maximum frequency	C=50 pF, 1.62 V ≤ V <sub>DD</sub> ≤ 2.7 V <sup>(4)</sup>	-	55	MHz
			C=30 pF, 1.62 V ≤ V <sub>DD</sub> ≤ 2.7 V <sup>(4)</sup>	-	80	
			C=10 pF, 1.62 V ≤ V <sub>DD</sub> ≤ 2.7 V <sup>(4)</sup>	-	133	
	$t_r/t_f^{(3)}$	Output high to low level fall time and output low to high level rise time	C=30 pF, 1.62 V ≤ V <sub>DD</sub> ≤ 2.7 V <sup>(4)</sup>	-	5.8	ns
			C=30 pF, 1.62 V ≤ V <sub>DD</sub> ≤ 2.7 V <sup>(4)</sup>	-	4	
			C=30 pF, 1.62 V ≤ V <sub>DD</sub> ≤ 2.7 V <sup>(4)</sup>	-	2.4	
11	$F_{\max}^{(2)}$	Maximum frequency	C=30 pF, 1.62 V ≤ V <sub>DD</sub> ≤ 2.7 V <sup>(4)</sup>	-	60	MHz
			C=30 pF, 1.62 V ≤ V <sub>DD</sub> ≤ 2.7 V <sup>(4)</sup>	-	90	
			C=30 pF, 1.62 V ≤ V <sub>DD</sub> ≤ 2.7 V <sup>(4)</sup>	-	175	
	$t_r/t_f^{(3)}$	Output high to low level fall time and output low to high level rise time	C=30 pF, 1.62 V ≤ V <sub>DD</sub> ≤ 2.7 V <sup>(4)</sup>	-	5.3	ns
			C=30 pF, 1.62 V ≤ V <sub>DD</sub> ≤ 2.7 V <sup>(4)</sup>	-	3.6	
			C=30 pF, 1.62 V ≤ V <sub>DD</sub> ≤ 2.7 V <sup>(4)</sup>	-	1.9	

1. Guaranteed by design.

2. The maximum frequency is defined with the following conditions:  
 $(t_r + t_f) \leq 2/3 T$   
 Skew ≤ 1/20 T  
 45% < Duty cycle < 55%

3. The fall and rise times are defined between 90% and 10% and between 10% and 90% of the output waveform, respectively.

4. Compensation system enabled.

### 7.3.16 NRST pin characteristics

The NRST pin input driver uses CMOS technology. It is connected to a permanent pull-up resistor,  $R_{PU}$  (see [Table 155: I/O static characteristics](#)).

Unless otherwise specified, the parameters given in [Table 160](#) are derived from tests performed under the ambient temperature and  $V_{DD}$  supply voltage conditions summarized in [Table 120: General operating conditions](#).

**Table 160. NRST pin characteristics**

Symbol	Parameter	Conditions	Min	Typ	Max	Unit
$R_{PU}^{(2)}$	Weak pull-up equivalent resistor <sup>(1)</sup>	$V_{IN} = V_{SS}$	30	40	50	?
$V_{F(NRST)}^{(2)}$	NRST Input filtered pulse	$1.71\text{ V} < V_{DD} < 3.6\text{ V}$	-	-	50	ns
$V_{NF(NRST)}^{(2)}$	NRST Input not filtered pulse	$1.71\text{ V} < V_{DD} < 3.6\text{ V}$	300	-	-	
		$1.62\text{ V} < V_{DD} < 3.6\text{ V}$	1000	-	-	

1. The pull-up is designed with a true resistance in series with a switchable PMOS. This PMOS contribution to the series resistance must be minimum (~10% order).
2. Guaranteed by design.

**Figure 72. Recommended NRST pin protection**

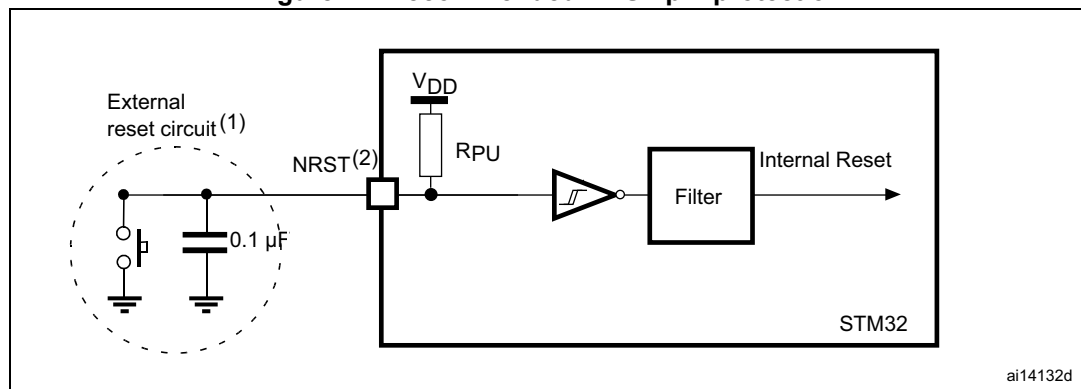

1. The reset network protects the device against parasitic resets.
2. The user must ensure that the level on the NRST pin can go below the  $V_{IL(NRST)}$  max level specified in [Table 155](#). Otherwise the reset is not taken into account by the device.

### 7.3.17 FMC characteristics

Unless otherwise specified, the parameters given in [Table 161](#) to [Table 174](#) for the FMC interface are derived from tests performed under the ambient temperature,  $f_{HCLK}$  frequency and  $V_{DD}$  supply voltage conditions summarized in [Table 120: General operating conditions](#), with the following configuration:

- Output speed is set to  $OSPEEDRy[1:0] = 11$
- Measurement points are done at CMOS levels:  $0.5V_{DD}$
- IO Compensation cell activated.
- HSLV activated when  $V_{DD} \leq 2.7\text{ V}$
- VOS level set to VOS1.

Refer to [Section 7.3.15: I/O port characteristics](#) for more details on the input/output alternate function characteristics.

### Asynchronous waveforms and timings

[Figure 73](#) through [Figure 75](#) represent asynchronous waveforms and [Table 161](#) through [Table 168](#) provide the corresponding timings. The results shown in these tables are obtained with the following FMC configuration:

- AddressSetupTime = 0x1
- AddressHoldTime = 0x1
- DataSetupTime = 0x1 (except for asynchronous NWAIT mode , DataSetupTime = 0x5)
- BusTurnAroundDuration = 0x0
- Capacitive load  $C_L = 30$  pF

In all timing tables, the  $T_{KERCK}$  is the  $f_{mc\_ker\_ck}$  clock period.

**Figure 73. Asynchronous non-multiplexed SRAM/PSRAM/NOR read waveforms**

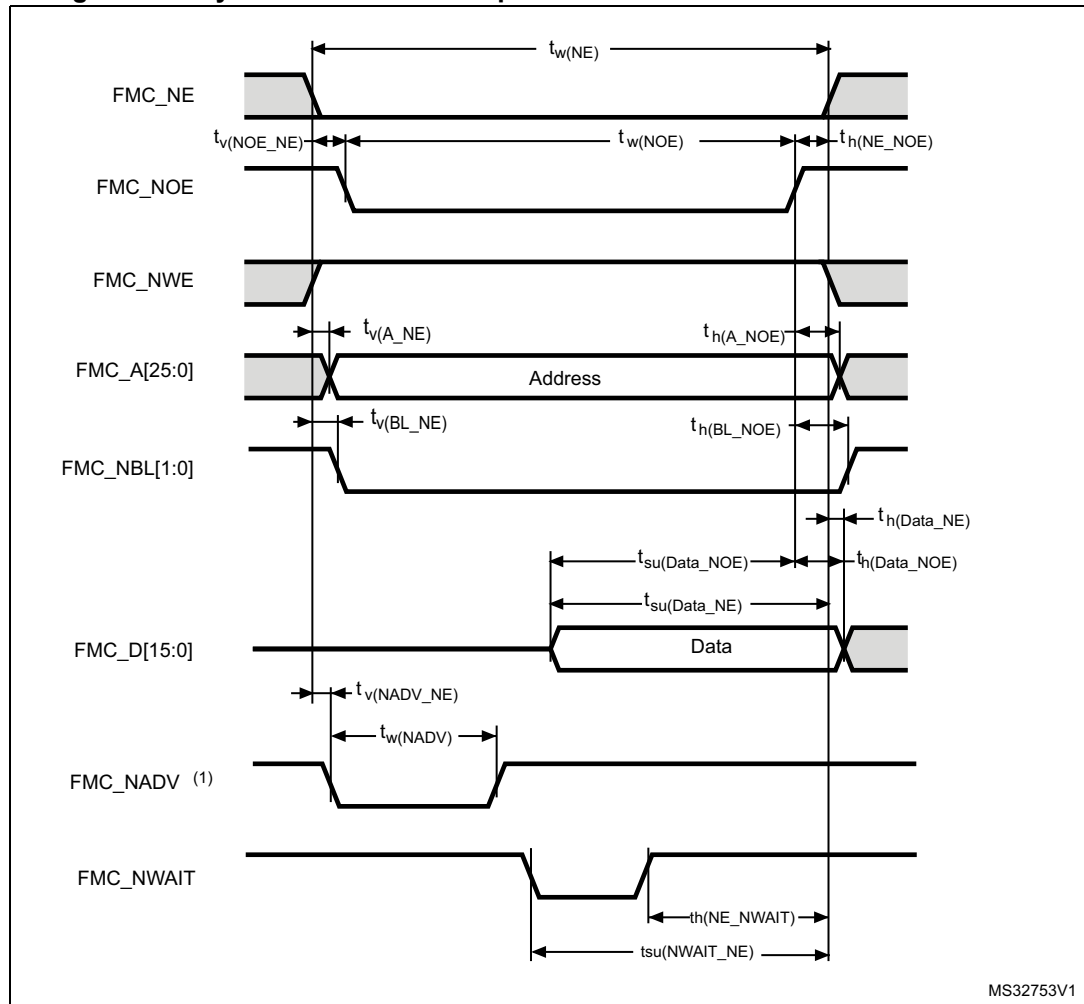

1. Mode 2/B, C and D only. In Mode 1, FMC\_NADV is not used.

**Table 161. Asynchronous non-multiplexed SRAM/PSRAM/NOR read timings<sup>(1)</sup>**

Symbol	Parameter	Min	Max	Unit
$t_{w(NE)}$	FMC_NE low time	$3T_{fmc\_ker\_ck}-1$	$3T_{fmc\_ker\_ck}+1$	ns
$t_{v(NOE\_NE)}$	FMC_NEx low to FMC_NOE low	0	0.5	
$t_{w(NOE)}$	FMC_NOE low time	$2T_{fmc\_ker\_ck}-1$	$2T_{fmc\_ker\_ck}+1$	
$t_{h(NE\_NOE)}$	FMC_NOE high to FMC_NE high hold time	0	-	
$t_{v(A\_NE)}$	FMC_NEx low to FMC_A valid	-	0.5	
$t_{h(A\_NOE)}$	Address hold time after FMC_NOE high	0	-	
$t_{su(Data\_NE)}$	Data to FMC_NEx high setup time	11	-	
$t_{su(Data\_NOE)}$	Data to FMC_NOEx high setup time	11	-	
$t_{h(Data\_NOE)}$	Data hold time after FMC_NOE high	0	-	
$t_{h(Data\_NE)}$	Data hold time after FMC_NEx high	0	-	
$t_{v(NADV\_NE)}$	FMC_NEx low to FMC_NADV low	-	0	
$t_{w(NADV)}$	FMC_NADV low time	-	$T_{fmc\_ker\_ck}+1$	

1. Guaranteed by characterization results.

**Table 162. Asynchronous non-multiplexed SRAM/PSRAM/NOR read-NWAIT timings<sup>(1)(2)</sup>**

Symbol	Parameter	Min	Max	Unit
$t_{w(NE)}$	FMC_NE low time	$7T_{fmc\_ker\_ck}+1$	$7T_{fmc\_ker\_ck}+1$	ns
$t_{w(NOE)}$	FMC_NOE low time	$5T_{fmc\_ker\_ck}-1$	$5T_{fmc\_ker\_ck}+1$	
$t_{w(NWAIT)}$	FMC_NWAIT low time	$T_{fmc\_ker\_ck}-0.5$	-	
$t_{su(NWAIT\_NE)}$	FMC_NWAIT valid before FMC_NEx high	$4T_{fmc\_ker\_ck}+11$	-	
$t_{h(NE\_NWAIT)}$	FMC_NEx hold time after FMC_NWAIT invalid	$3T_{fmc\_ker\_ck}+11.5$	-	

1. Guaranteed by characterization results.

2.  $N_{WAIT}$  pulse width is equal to 1 AHB cycle.

Figure 74. Asynchronous non-multiplexed SRAM/PSRAM/NOR write waveforms

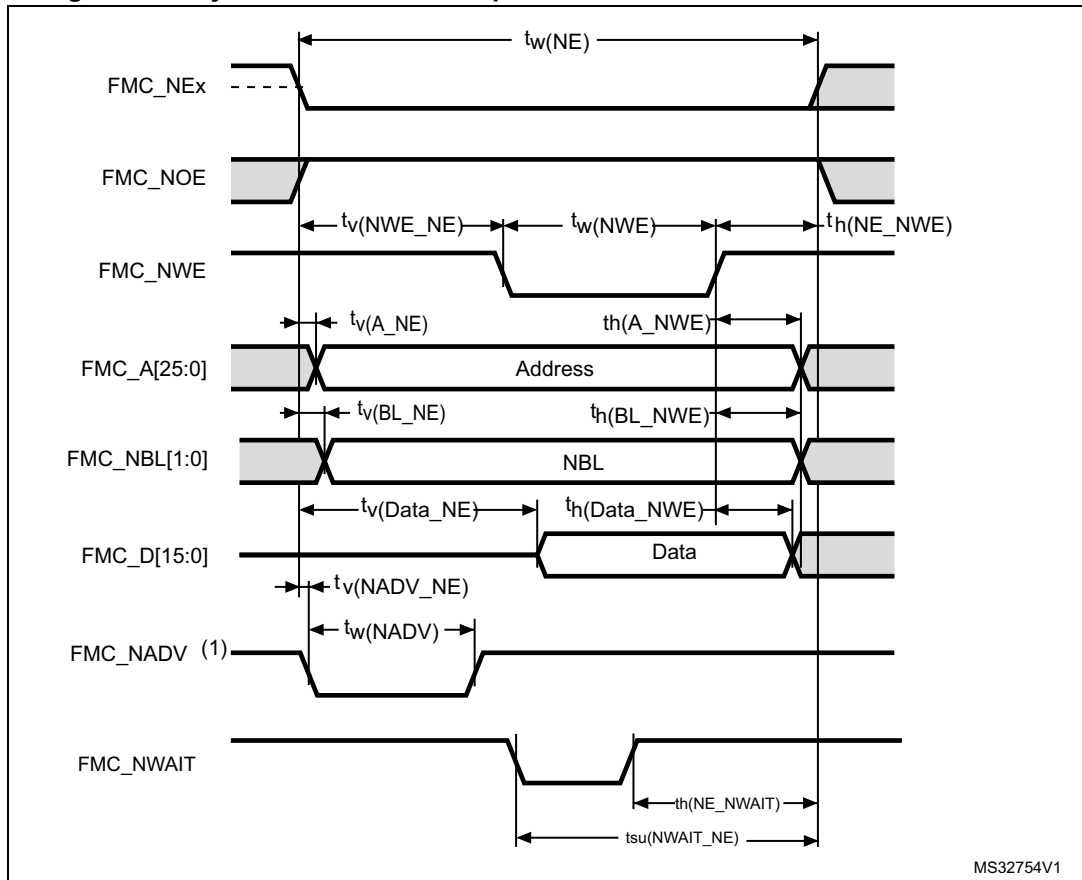

MS32754V1

1. Mode 2/B, C and D only. In Mode 1, FMC\_NADV is not used.

**Table 163. Asynchronous non-multiplexed SRAM/PSRAM/NOR write timings<sup>(1)</sup>**

Symbol	Parameter	Min	Max	Unit
$t_{w(NE)}$	FMC_NE low time	$3T_{fmc\_ker\_ck} - 1$	$3T_{fmc\_ker\_ck}$	ns
$t_{v(NWE\_NE)}$	FMC_NEx low to FMC_NWE low	$T_{fmc\_ker\_ck}$	$T_{fmc\_ker\_ck} + 1$	
$t_{w(NWE)}$	FMC_NWE low time	$T_{fmc\_ker\_ck} - 0.5$	$T_{fmc\_ker\_ck} + 0.5$	
$t_{h(NE\_NWE)}$	FMC_NWE high to FMC_NE high hold time	$T_{fmc\_ker\_ck}$	-	
$t_{v(A\_NE)}$	FMC_NEx low to FMC_A valid	-	2	
$t_{h(A\_NWE)}$	Address hold time after FMC_NWE high	$T_{fmc\_ker\_ck} - 0.5$	-	
$t_{v(BL\_NE)}$	FMC_NEx low to FMC_BL valid	-	0.5	
$t_{h(BL\_NWE)}$	FMC_BL hold time after FMC_NWE high	$T_{fmc\_ker\_ck} - 0.5$	-	
$t_{v(Data\_NE)}$	Data to FMC_NEx low to Data valid	-	$T_{fmc\_ker\_ck} + 2.5$	
$t_{h(Data\_NWE)}$	Data hold time after FMC_NWE high	$T_{fmc\_ker\_ck} + 0.5$	-	
$t_{v(NADV\_NE)}$	FMC_NEx low to FMC_NADV low	-	0	
$t_{w(NADV)}$	FMC_NADV low time	-	$T_{fmc\_ker\_ck} + 1$	

1. Guaranteed by characterization results.

**Table 164. Asynchronous non-multiplexed SRAM/PSRAM/NOR write-NWAIT timings<sup>(1)(2)</sup>**

Symbol	Parameter	Min	Max	Unit
$t_{w(NE)}$	FMC_NE low time	$8T_{fmc\_ker\_ck} - 1$	$8T_{fmc\_ker\_ck} + 1$	ns
$t_{w(NWE)}$	FMC_NWE low time	$6T_{fmc\_ker\_ck} - 1.5$	$6T_{fmc\_ker\_ck} + 0.5$	
$t_{su(NWAIT\_NE)}$	FMC_NWAIT valid before FMC_NEx high	$5T_{fmc\_ker\_ck} + 13$	-	
$t_{h(NE\_NWAIT)}$	FMC_NEx hold time after FMC_NWAIT invalid	$4T_{fmc\_ker\_ck} + 13$	-	

1. Guaranteed by characterization results.

2.  $N_{WAIT}$  pulse width is equal to 1 AHB cycle.

Figure 75. Asynchronous multiplexed PSRAM/NOR read waveforms

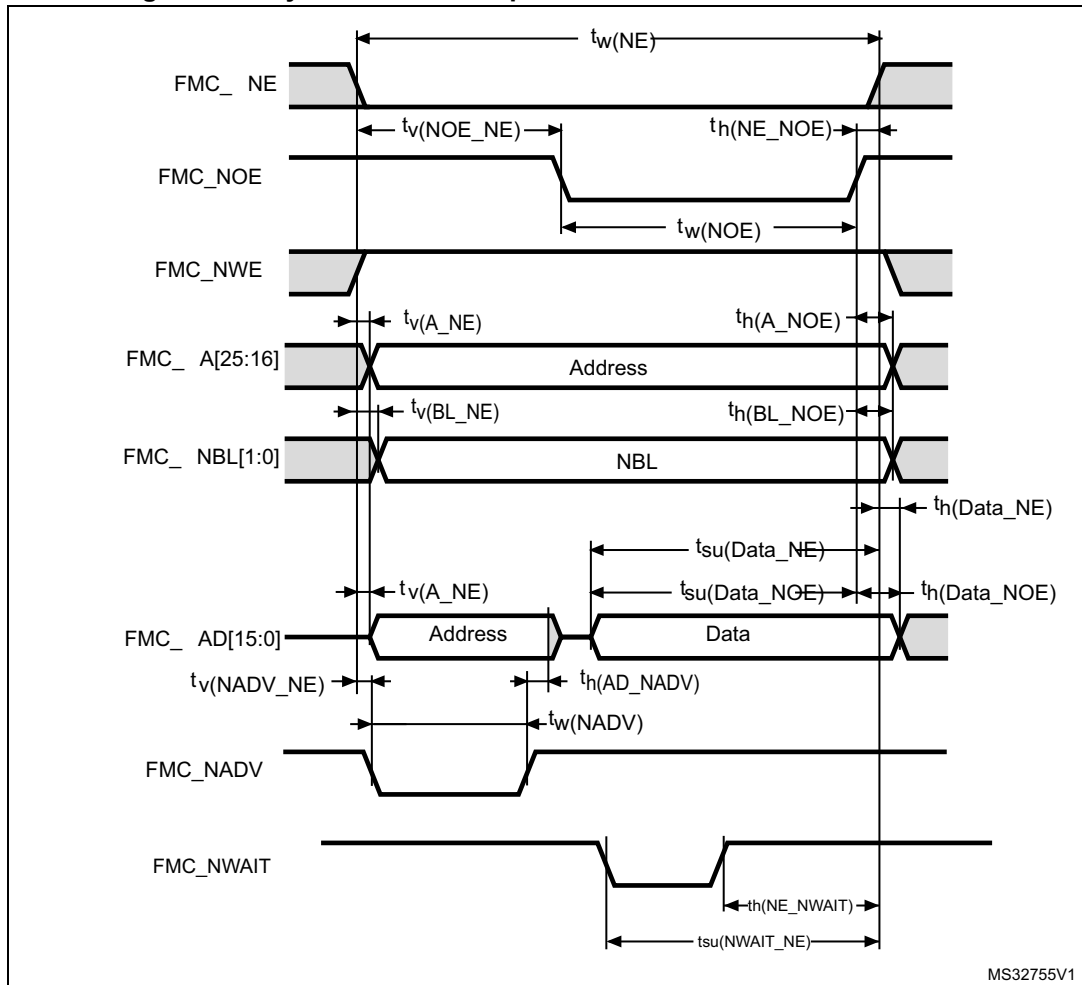



**Table 165. Asynchronous multiplexed PSRAM/NOR read timings<sup>(1)</sup>**

Symbol	Parameter	Min	Max	Unit
$t_{w(NE)}$	FMC_NE low time	$4T_{fmc\_ker\_ck} - 1$	$4T_{fmc\_ker\_ck} + 1$	ns
$t_{v(NOE\_NE)}$	FMC_NEx low to FMC_NOE low	$2T_{fmc\_ker\_ck}$	$2T_{fmc\_ker\_ck} + 0.5$	
$t_{tw(NOE)}$	FMC_NOE low time	$T_{fmc\_ker\_ck} - 1$	$T_{fmc\_ker\_ck} + 1$	
$t_{h(NE\_NOE)}$	FMC_NOE high to FMC_NE high hold time	0	-	
$t_{v(A\_NE)}$	FMC_NEx low to FMC_A valid	-	0.5	
$t_{v(NADV\_NE)}$	FMC_NEx low to FMC_NADV low	0	0.5	
$t_{w(NADV)}$	FMC_NADV low time	$T_{fmc\_ker\_ck} - 0.5$	$T_{fmc\_ker\_ck} + 1$	
$t_{h(AD\_NADV)}$	FMC_AD(address) valid hold time after FMC_NADV high	$T_{fmc\_ker\_ck} + 0.5$	-	
$t_{h(A\_NOE)}$	Address hold time after FMC_NOE high	$T_{fmc\_ker\_ck} - 0.5$	-	
$t_{su(Data\_NE)}$	Data to FMC_NEx high setup time	11	-	
$t_{su(Data\_NOE)}$	Data to FMC_NOE high setup time	11	-	
$t_{h(Data\_NE)}$	Data hold time after FMC_NEx high	0	-	
$t_{h(Data\_NOE)}$	Data hold time after FMC_NOE high	0	-	

1. Guaranteed by characterization results.

**Table 166. Asynchronous multiplexed PSRAM/NOR read-NWAIT timings<sup>(1)(2)</sup>**

Symbol	Parameter	Min	Max	Unit
$t_{w(NE)}$	FMC_NE low time	$8T_{fmc\_ker\_ck} - 1$	$8T_{fmc\_ker\_ck}$	ns
$t_{w(NOE)}$	FMC_NWE low time	$5T_{fmc\_ker\_ck} - 1.5$	$5T_{fmc\_ker\_ck} + 0.5$	
$t_{su(NWAIT\_NE)}$	FMC_NWAIT valid before FMC_NEx high	$4T_{fmc\_ker\_ck} + 11$	-	
$t_{h(NE\_NWAIT)}$	FMC_NEx hold time after FMC_NWAIT invalid	$3T_{fmc\_ker\_ck} + 11.5$	-	

1. Guaranteed by characterization results.

2.  $N_{WAIT}$  pulse width is equal to 1 AHB cycle.

Table 167. Asynchronous multiplexed PSRAM/NOR write timings<sup>(1)</sup>

Symbol	Parameter	Min	Max	Unit
$t_{w(NE)}$	FMC_NE low time	$4T_{fmc\_ker\_ck} - 1$	$4T_{fmc\_ker\_ck}$	ns
$t_{v(NWE\_NE)}$	FMC_NEx low to FMC_NWE low	$T_{fmc\_ker\_ck} - 1$	$T_{fmc\_ker\_ck} + 0.5$	
$t_{w(NWE)}$	FMC_NWE low time	$2T_{fmc\_ker\_ck} - 0.5$	$2T_{fmc\_ker\_ck} + 0.5$	
$t_{h(NE\_NWE)}$	FMC_NWE high to FMC_NE high hold time	$T_{fmc\_ker\_ck} - 0.5$	-	
$t_{v(A\_NE)}$	FMC_NEx low to FMC_A valid	-	0	
$t_{v(NADV\_NE)}$	FMC_NEx low to FMC_NADV low	0	0.5	
$t_{w(NADV)}$	FMC_NADV low time	$T_{fmc\_ker\_ck}$	$T_{fmc\_ker\_ck} + 1$	
$t_{h(AD\_NADV)}$	FMC_AD(address) valid hold time after FMC_NADV high	$T_{fmc\_ker\_ck} + 0.5$	-	
$t_{h(A\_NWE)}$	Address hold time after FMC_NWE high	$T_{fmc\_ker\_ck} + 0.5$	-	
$t_{h(BL\_NWE)}$	FMC_BL hold time after FMC_NWE high	$T_{fmc\_ker\_ck} - 0.5$	-	
$t_{v(BL\_NE)}$	FMC_NEx low to FMC_BL valid	-	0.5	
$t_{v(Data\_NADV)}$	FMC_NADV high to Data valid	-	$T_{fmc\_ker\_ck} + 2$	
$t_{h(Data\_NWE)}$	Data hold time after FMC_NWE high	$T_{fmc\_ker\_ck} + 0.5$	-	

1. Guaranteed by characterization results.

Table 168. Asynchronous multiplexed PSRAM/NOR write-NWAIT timings<sup>(1)(2)</sup>

Symbol	Parameter	Min	Max	Unit
$t_{w(NE)}$	FMC_NE low time	$9T_{fmc\_ker\_ck} - 1$	$9T_{fmc\_ker\_ck}$	ns
$t_{w(NWE)}$	FMC_NWE low time	$7T_{fmc\_ker\_ck} - 0.5$	$7T_{fmc\_ker\_ck} + 0.5$	
$t_{su(NWAIT\_NE)}$	FMC_NWAIT valid before FMC_NEx high	$5T_{fmc\_ker\_ck} + 11$	-	
$t_{h(NE\_NWAIT)}$	FMC_NEx hold time after FMC_NWAIT invalid	$4T_{fmc\_ker\_ck} + 11.5$	-	

1. Guaranteed by characterization results.

2.  $N_{WAIT}$  pulse width is equal to 1 AHB cycle.

## Synchronous waveforms and timings

Figure 76 through Figure 79 represent synchronous waveforms and Table 169 through Table 172 provide the corresponding timings. The results shown in these tables are obtained with the following FMC configuration:

- BurstAccessMode = FMC\_BurstAccessMode\_Enable
- MemoryType = FMC\_MemoryType\_CRAM
- WriteBurst = FMC\_WriteBurst\_Enable
- CLKDivision = 1
- DataLatency = 1 for NOR Flash; DataLatency = 0 for PSRAM

In all the timing tables, the  $T_{fmc\_ker\_ck}$  is the  $f_{fmc\_ker\_ck}$  clock period, with the following FMC\_CLK maximum values:

- For  $2.7\text{ V} < V_{DD} < 3.6\text{ V}$ , FMC\_CLK = 125 MHz at 20 pF
- For  $1.8\text{ V} < V_{DD} < 1.9\text{ V}$ , FMC\_CLK = 100 MHz at 20 pF
- For  $1.62\text{ V} < V_{DD} < 1.8\text{ V}$ , FMC\_CLK = 100 MHz at 15 pF

Figure 76. Synchronous multiplexed NOR/PSRAM read timings

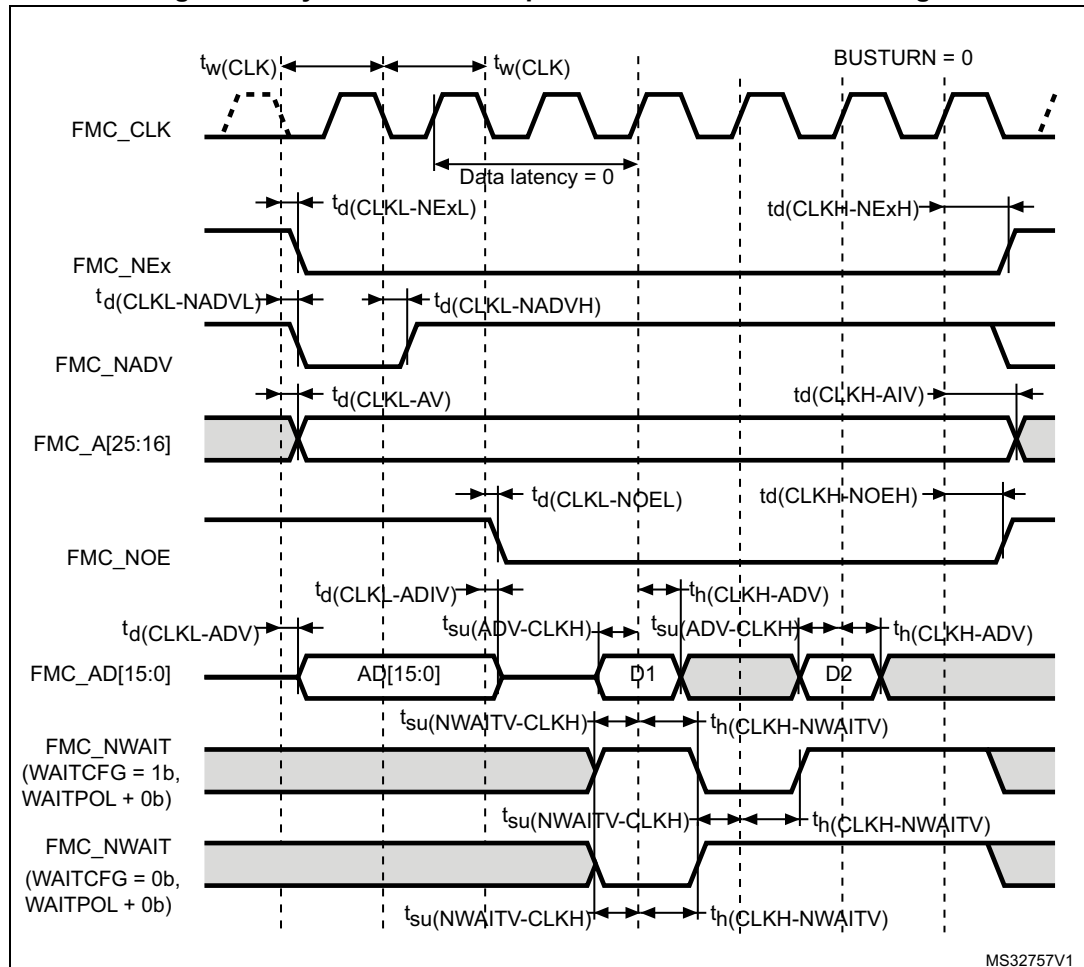

Table 169. Synchronous multiplexed NOR/PSRAM read timings<sup>(1)</sup>

Symbol	Parameter	Min	Max	Unit
$t_w(\text{CLK})$	FMC_CLK period	$2T_{\text{fmc\_ker\_ck}} - 1$	-	ns
$t_d(\text{CLKL-NEXL})$	FMC_CLK low to FMC_NEx low ( $x=0..2$ )	-	1	
$t_d(\text{CLKH-NEXH})$	FMC_CLK high to FMC_NEx high ( $x=0..2$ )	$T_{\text{fmc\_ker\_ck}} + 0.5$	-	
$t_d(\text{CLKL-NADVL})$	FMC_CLK low to FMC_NADV low	-	1	
$t_d(\text{CLKL-NADVH})$	FMC_CLK low to FMC_NADV high	0	-	
$t_d(\text{CLKL-AV})$	FMC_CLK low to FMC_Ax valid ( $x=16..25$ )	-	2.5	
$t_d(\text{CLKH-AIV})$	FMC_CLK high to FMC_Ax invalid ( $x=16..25$ )	$T_{\text{fmc\_ker\_ck}}$	-	
$t_d(\text{CLKL-NOEL})$	FMC_CLK low to FMC_NOE low	-	1.5	
$t_d(\text{CLKH-NOEH})$	FMC_CLK high to FMC_NOE high	$T_{\text{fmc\_ker\_ck}} - 0.5$	-	
$t_d(\text{CLKL-ADV})$	FMC_CLK low to FMC_AD[15:0] valid	-	3	
$t_d(\text{CLKL-ADIV})$	FMC_CLK low to FMC_AD[15:0] invalid	0	-	
$t_{su}(\text{ADV-CLKH})$	FMC_A/D[15:0] valid data before FMC_CLK high	2	-	
$t_h(\text{CLKH-ADV})$	FMC_A/D[15:0] valid data after FMC_CLK high	1	-	
$t_{su}(\text{NWAIT-CLKH})$	FMC_NWAIT valid before FMC_CLK high	2	-	
$t_h(\text{CLKH-NWAIT})$	FMC_NWAIT valid after FMC_CLK high	2	-	

1. Guaranteed by characterization results.

Figure 77. Synchronous multiplexed PSRAM write timings

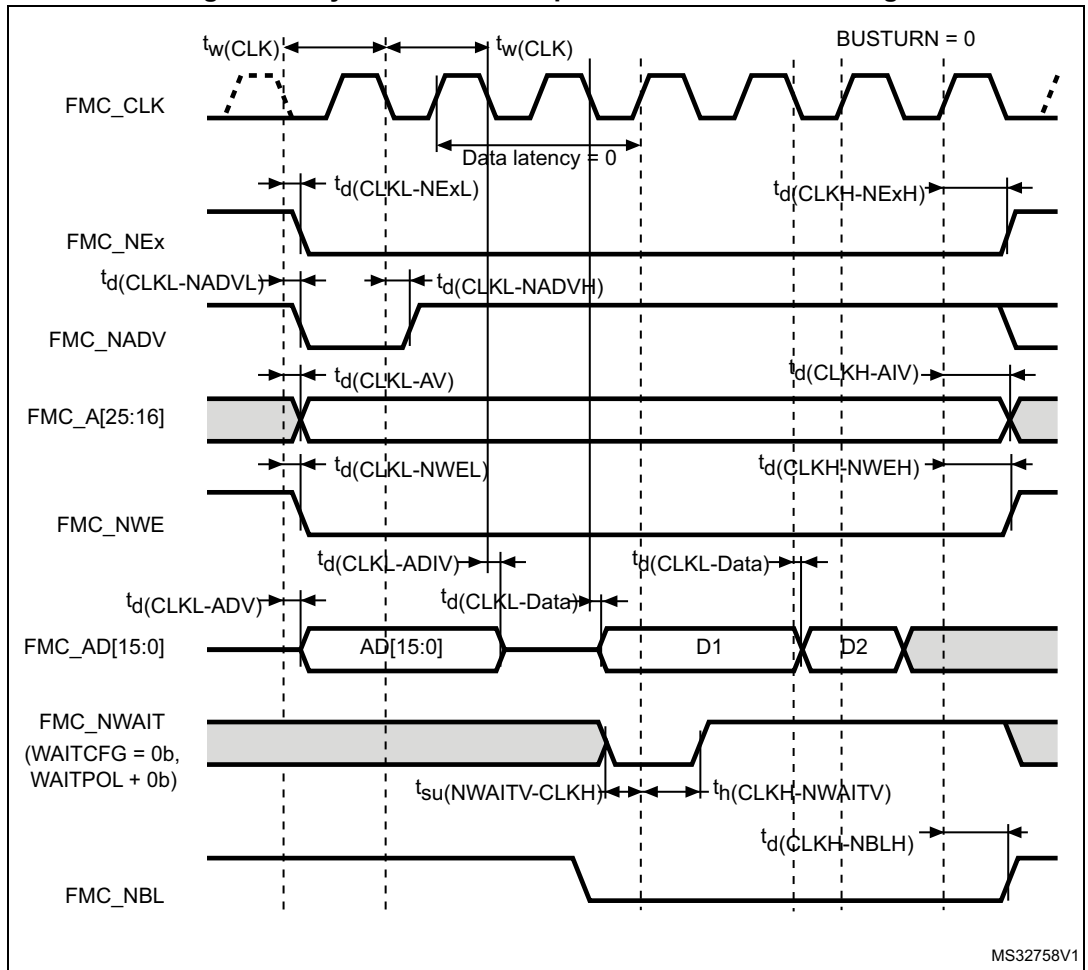

Table 170. Synchronous multiplexed PSRAM write timings<sup>(1)</sup>

Symbol	Parameter	Min	Max	Unit
$t_{w(\text{CLK})}$	FMC_CLK period, $V_{DD} = 2.7$ to $3.6$ V	$\frac{2T_{fmc\_ker\_ck}-1}{1}$	-	Ns
$t_{d(\text{CLKL-NEXL})}$	FMC_CLK low to FMC_NEx low ( $x = 0..2$ )	-	1	
$t_{d(\text{CLKH-NEXH})}$	FMC_CLK high to FMC_NEx high ( $x = 0..2$ )	$T_{fmc\_ker\_ck} + 0.5$	-	
$t_{d(\text{CLKL-NADV})}$	FMC_CLK low to FMC_NADV low	-	1.5	
$t_{d(\text{CLKL-NADVH})}$	FMC_CLK low to FMC_NADV high	0	-	
$t_{d(\text{CLKL-AV})}$	FMC_CLK low to FMC_Ax valid ( $x = 16..25$ )	-	2	
$t_{d(\text{CLKH-AIV})}$	FMC_CLK high to FMC_Ax invalid ( $x = 16..25$ )	$T_{fmc\_ker\_ck}$	-	
$t_{d(\text{CLKL-NWEL})}$	FMC_CLK low to FMC_NWE low	-	1.5	
$t_{d(\text{CLKH-NWEH})}$	FMC_CLK high to FMC_NWE high	$T_{fmc\_ker\_ck} + 0.5$	-	
$t_{d(\text{CLKL-ADV})}$	FMC_CLK low to FMC_AD[15:0] valid	-	2.5	
$t_{d(\text{CLKL-ADIV})}$	FMC_CLK low to FMC_AD[15:0] invalid	0	-	
$t_{d(\text{CLKL-DATA})}$	FMC_A/D[15:0] valid data after FMC_CLK low	-	2.5	
$t_{d(\text{CLKL-NBLL})}$	FMC_CLK low to FMC_NBL low	-	2	
$t_{d(\text{CLKH-NBLH})}$	FMC_CLK high to FMC_NBL high	$T_{fmc\_ker\_ck} + 0.5$	-	
$t_{su(\text{NWAIT-CLKH})}$	FMC_NWAIT valid before FMC_CLK high	2	-	
$t_h(\text{CLKH-NWAIT})$	FMC_NWAIT valid after FMC_CLK high	2	-	

1. Guaranteed by characterization results.

Figure 78. Synchronous non-multiplexed NOR/PSRAM read timings

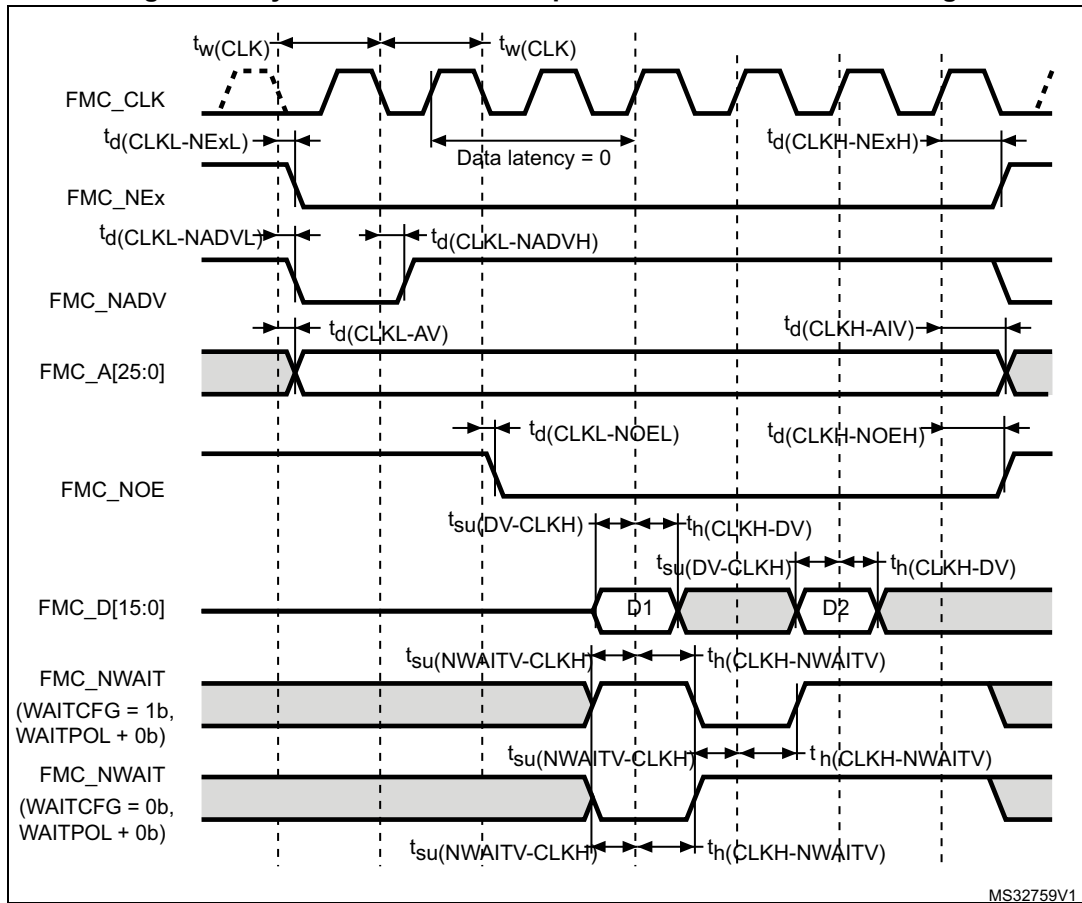

Table 171. Synchronous non-multiplexed NOR/PSRAM read timings<sup>(1)</sup>

Symbol	Parameter	Min	Max	Unit
$t_{w(\text{CLK})}$	FMC_CLK period	$2T_{\text{fmc\_ker\_ck}}-1$	-	ns
$t_{(\text{CLKL-NExL})}$	FMC_CLK low to FMC_NEx low (x=0..2)	-	1	
$t_{d(\text{CLKH-NExH})}$	FMC_CLK high to FMC_NEx high (x= 0..2)	$2T_{\text{fmc\_ker\_ck}}+0.5$	-	
$t_{d(\text{CLKL-NADV})}$	FMC_CLK low to FMC_NADV low	-	0.5	
$t_{d(\text{CLKL-NADVH})}$	FMC_CLK low to FMC_NADV high	0	-	
$t_{d(\text{CLKL-AV})}$	FMC_CLK low to FMC_Ax valid (x=16...25)	-	2	
$t_{d(\text{CLKH-AIV})}$	FMC_CLK high to FMC_Ax invalid (x=16...25)	$2T_{\text{fmc\_ker\_ck}}$	-	
$t_{d(\text{CLKL-NOEL})}$	FMC_CLK low to FMC_NOE low	-	1.5	
$t_{d(\text{CLKH-NOEH})}$	FMC_CLK high to FMC_NOE high	$2T_{\text{fmc\_ker\_ck}}-0.5$	-	
$t_{\text{su}(\text{DV-CLKH})}$	FMC_D[15:0] valid data before FMC_CLK high	2	-	
$t_{\text{h}(\text{CLKH-DV})}$	FMC_D[15:0] valid data after FMC_CLK high	1	-	
$t_{(\text{NWAIT-CLKH})}$	FMC_NWAIT valid before FMC_CLK high	2	-	
$t_{\text{h}(\text{CLKH-NWAIT})}$	FMC_NWAIT valid after FMC_CLK high	2	-	

1. Guaranteed by characterization results.



Figure 79. Synchronous non-multiplexed PSRAM write timings

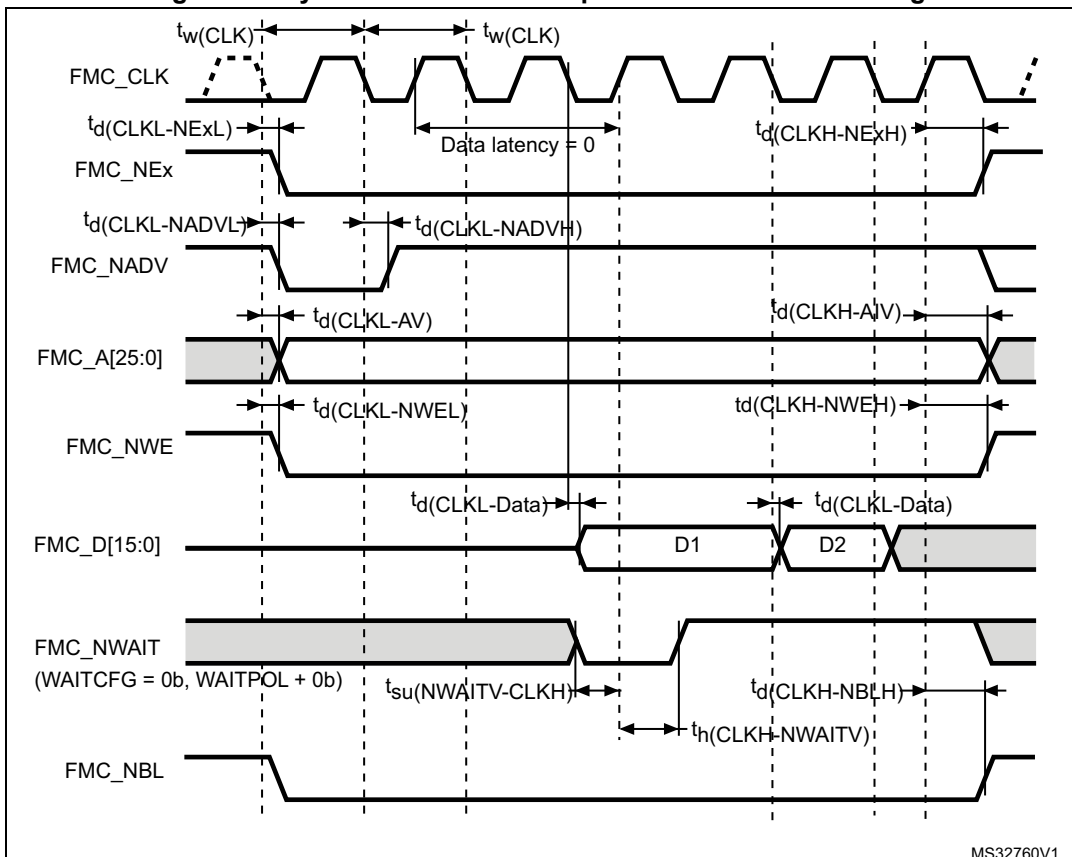

Table 172. Synchronous non-multiplexed PSRAM write timings<sup>(1)</sup>

Symbol	Parameter	Min	Max	Unit
$t_{(CLK)}$	FMC_CLK period	$2T_{fmc\_ker\_ck} - 1$	-	ns
$t_{d(CLKL-NEXL)}$	FMC_CLK low to FMC_NEx low (x=0..2)	-	2	
$t_{(CLKH-NEXH)}$	FMC_CLK high to FMC_NEx high (x= 0..2)	$T_{fmc\_ker\_ck} + 0.5$	-	
$t_{d(CLKL-NADV)}$	FMC_CLK low to FMC_NADV low	-	0.5	
$t_{d(CLKL-NADV)}$	FMC_CLK low to FMC_NADV high	0	-	
$t_{d(CLKL-AV)}$	FMC_CLK low to FMC_Ax valid (x=16...25)	-	2.	
$t_{d(CLKH-AIV)}$	FMC_CLK high to FMC_Ax invalid (x=16...25)	$T_{fmc\_ker\_ck}$	-	
$t_{d(CLKL-NWEL)}$	FMC_CLK low to FMC_NWE low	-	1.5	
$t_{d(CLKH-NWEH)}$	FMC_CLK high to FMC_NWE high	$T_{fmc\_ker\_ck} + 1$	-	
$t_{d(CLKL-Data)}$	FMC_D[15:0] valid data after FMC_CLK low	-	3.5	
$t_{d(CLKL-NBLL)}$	FMC_CLK low to FMC_NBL low	-	2	
$t_{d(CLKH-NBLH)}$	FMC_CLK high to FMC_NBL high	$T_{fmc\_ker\_ck} + 1$	-	
$t_{su(NWAIT-CLKH)}$	FMC_NWAIT valid before FMC_CLK high	2	-	
$t_{h(CLKH-NWAIT)}$	FMC_NWAIT valid after FMC_CLK high	2	-	

1. Guaranteed by characterization results.

**NAND controller waveforms and timings**

Figure 80 through Figure 83 represent synchronous waveforms, and Table 173 and Table 174 provide the corresponding timings. The results shown in this table are obtained with the following FMC configuration:

- COM.FMC\_SetupTime = 0x01
- COM.FMC\_WaitSetupTime = 0x03
- COM.FMC\_HoldSetupTime = 0x02
- COM.FMC\_HiZSetupTime = 0x01
- ATT.FMC\_SetupTime = 0x01
- ATT.FMC\_WaitSetupTime = 0x03
- ATT.FMC\_HoldSetupTime = 0x02
- ATT.FMC\_HiZSetupTime = 0x01
- Bank = FMC\_Bank\_NAND
- MemoryDataWidth = FMC\_MemoryDataWidth\_16b
- ECC = FMC\_ECC\_Enable
- ECCPageSize = FMC\_ECCPageSize\_512Bytes
- TCLRSetupTime = 0
- TARSetupTime = 0
- Capacitive load  $C_L = 30$  pF

In all timing tables, the  $T_{fmc\_ker\_ck}$  is the `fmc_ker_ck` clock period.

**Figure 80. NAND controller waveforms for read access**

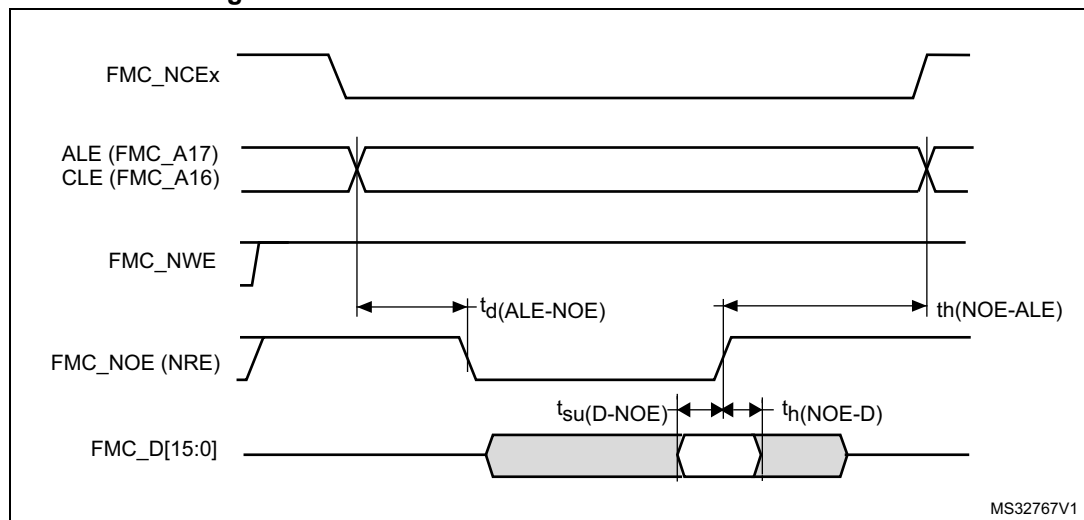

Figure 81. NAND controller waveforms for write access

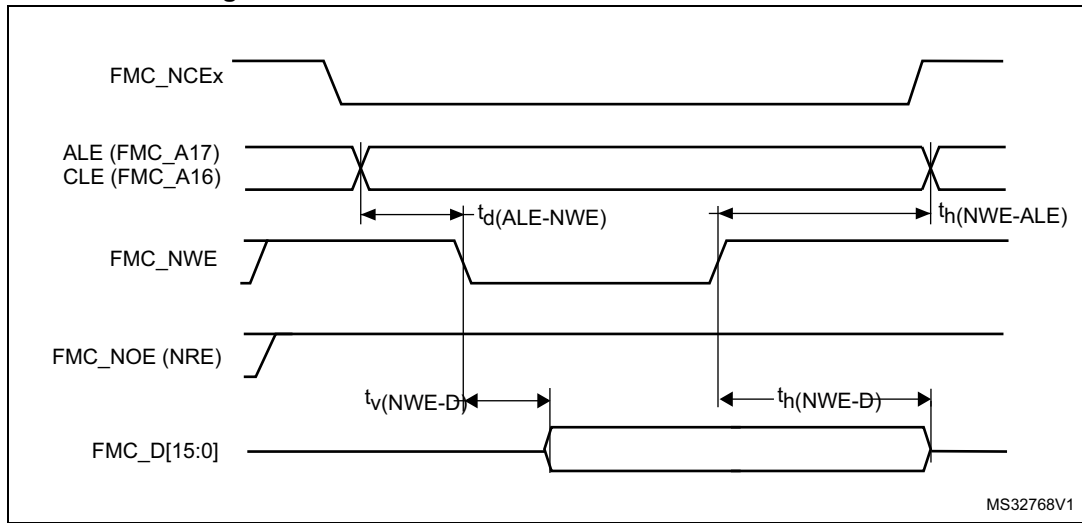

Figure 82. NAND controller waveforms for common memory read access

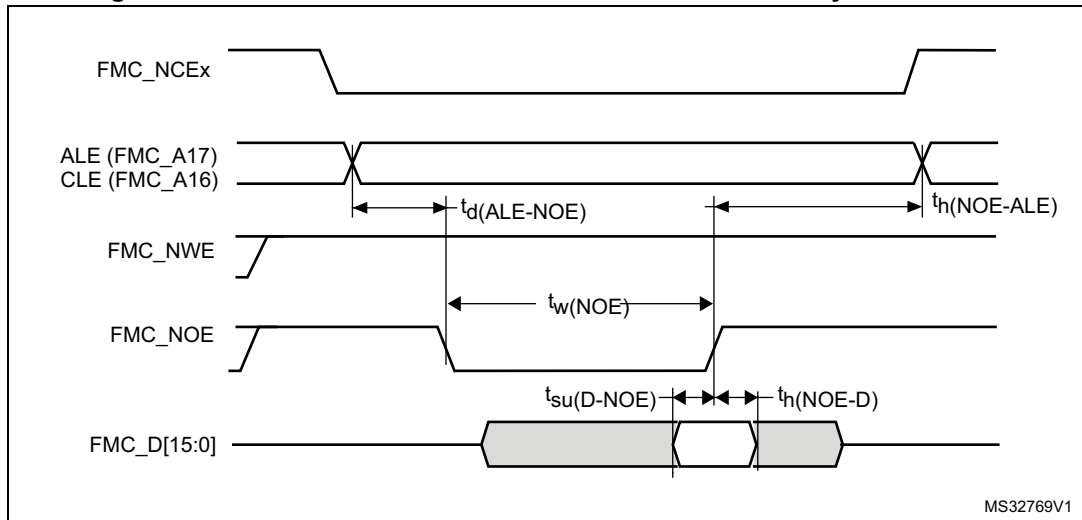

Figure 83. NAND controller waveforms for common memory write access

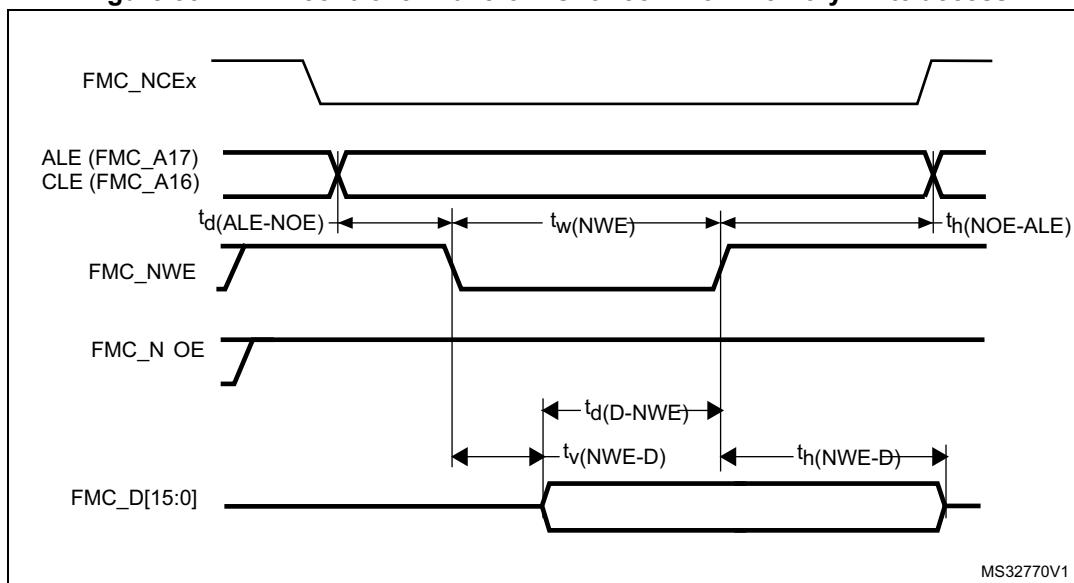

Table 173. Switching characteristics for NAND Flash read cycles<sup>(1)</sup>

Symbol	Parameter	Min	Max	Unit
$t_w(\text{NOE})$	FMC_NOE low width	$4T_{\text{fmc\_ker\_ck}} - 0.5$	$4T_{\text{fmc\_ker\_ck}} + 0.5$	ns
$t_{\text{su}}(\text{D-NOE})$	FMC_D[15-0] valid data before FMC_NOE high	8	-	
$t_h(\text{NOE-D})$	FMC_D[15-0] valid data after FMC_NOE high	0	-	
$t_d(\text{ALE-NOE})$	FMC_ALE valid before FMC_NOE low	-	$3T_{\text{fmc\_ker\_ck}} + 1$	
$t_h(\text{NOE-ALE})$	FMC_NWE high to FMC_ALE invalid	$4T_{\text{fmc\_ker\_ck}} - 2$	-	

1. Guaranteed by characterization results.

Table 174. Switching characteristics for NAND Flash write cycles<sup>(1)</sup>

Symbol	Parameter	Min	Max	Unit
$t_w(\text{NWE})$	FMC_NWE low width	$4T_{\text{fmc\_ker\_ck}} - 0.5$	$4T_{\text{fmc\_ker\_ck}} + 0.5$	ns
$t_v(\text{NWE-D})$	FMC_NWE low to FMC_D[15-0] valid	0	-	
$t_h(\text{NWE-D})$	FMC_NWE high to FMC_D[15-0] invalid	$2T_{\text{fmc\_ker\_ck}} - 0.5$	-	
$t_d(\text{D-NWE})$	FMC_D[15-0] valid before FMC_NWE high	$5T_{\text{fmc\_ker\_ck}} - 1$	-	
$t_d(\text{ALE-NWE})$	FMC_ALE valid before FMC_NWE low	-	$3T_{\text{fmc\_ker\_ck}} + 0.5$	
$t_h(\text{NWE-ALE})$	FMC_NWE high to FMC_ALE invalid	$2T_{\text{fmc\_ker\_ck}} - 1$	-	

1. Guaranteed by characterization results.

**SDRAM waveforms and timings**

In all timing tables, the TKERCK is the fmc\_ker\_ck clock period, with the following FMC\_SDCLK maximum values:

- For  $2.7\text{ V} < V_{DD} < 3.6\text{ V}$ : FMC\_CLK = 110 MHz at 20 pF
- For  $1.8\text{ V} < V_{DD} < 1.9\text{ V}$ : FMC\_CLK = 100 MHz at 20 pF
- For  $1.62\text{ V} < V_{DD} < 1.8\text{ V}$ , FMC\_CLK = 100 MHz at 15 pF

**Figure 84. SDRAM read access waveforms (CL = 1)**

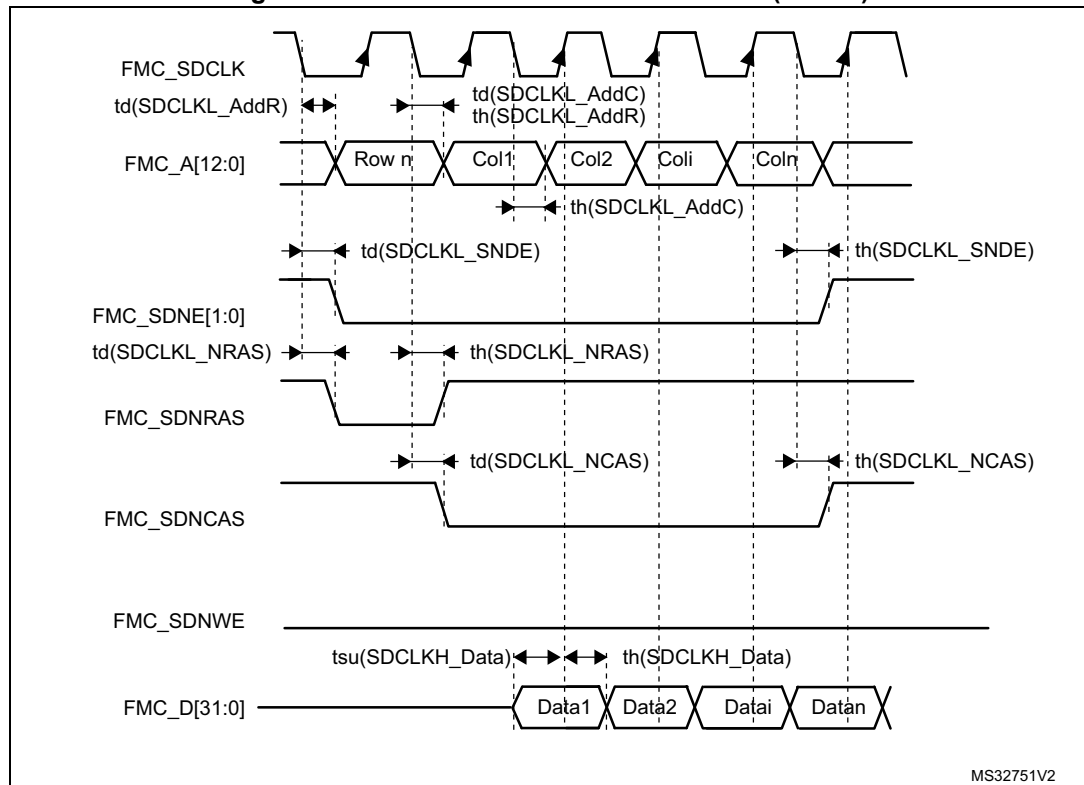

**Table 175. SDRAM read timings<sup>(1)</sup>**

Symbol	Parameter	Min	Max	Unit
$t_w(\text{SDCLK})$	FMC_SDCLK period	$2T_{\text{fmc\_ker\_ck}} - 1$	$2T_{\text{fmc\_ker\_ck}} + 0.5$	ns
$t_{\text{su}}(\text{SDCLKH\_Data})$	Data input setup time	2	-	
$t_h(\text{SDCLKH\_Data})$	Data input hold time	1	-	
$t_d(\text{SDCLKL\_Add})$	Address valid time	-	1.5	
$t_d(\text{SDCLKL\_SDNE})$	Chip select valid time	-	1.5	
$t_h(\text{SDCLKL\_SDNE})$	Chip select hold time	0.5	-	
$t_d(\text{SDCLKL\_SDNRAS})$	SDNRAS valid time	-	1	
$t_h(\text{SDCLKL\_SDNRAS})$	SDNRAS hold time	0.5	-	
$t_d(\text{SDCLKL\_SDNCAS})$	SDNCAS valid time	-	0.5	
$t_h(\text{SDCLKL\_SDNCAS})$	SDNCAS hold time	0	-	

1. Guaranteed by characterization results.

**Table 176. LPDDR SDRAM read timings<sup>(1)</sup>**

Symbol	Parameter	Min	Max	Unit
$t_w(\text{SDCLK})$	FMC_SDCLK period	$2T_{\text{fmc\_ker\_ck}} - 1$	$2T_{\text{fmc\_ker\_ck}} + 0.5$	ns
$t_{\text{su}}(\text{SDCLKH\_Data})$	Data input setup time	2	-	
$t_h(\text{SDCLKH\_Data})$	Data input hold time	1.5	-	
$t_d(\text{SDCLKL\_Add})$	Address valid time	-	2.5	
$t_d(\text{SDCLKL\_SDNE})$	Chip select valid time	-	2.5	
$t_h(\text{SDCLKL\_SDNE})$	Chip select hold time	0	-	
$t_d(\text{SDCLKL\_SDNRAS})$	SDNRAS valid time	-	0.5	
$t_h(\text{SDCLKL\_SDNRAS})$	SDNRAS hold time	0	-	
$t_d(\text{SDCLKL\_SDNCAS})$	SDNCAS valid time	-	1.5	
$t_h(\text{SDCLKL\_SDNCAS})$	SDNCAS hold time	0	-	

1. Guaranteed by characterization results.

Figure 85. SDRAM write access waveforms

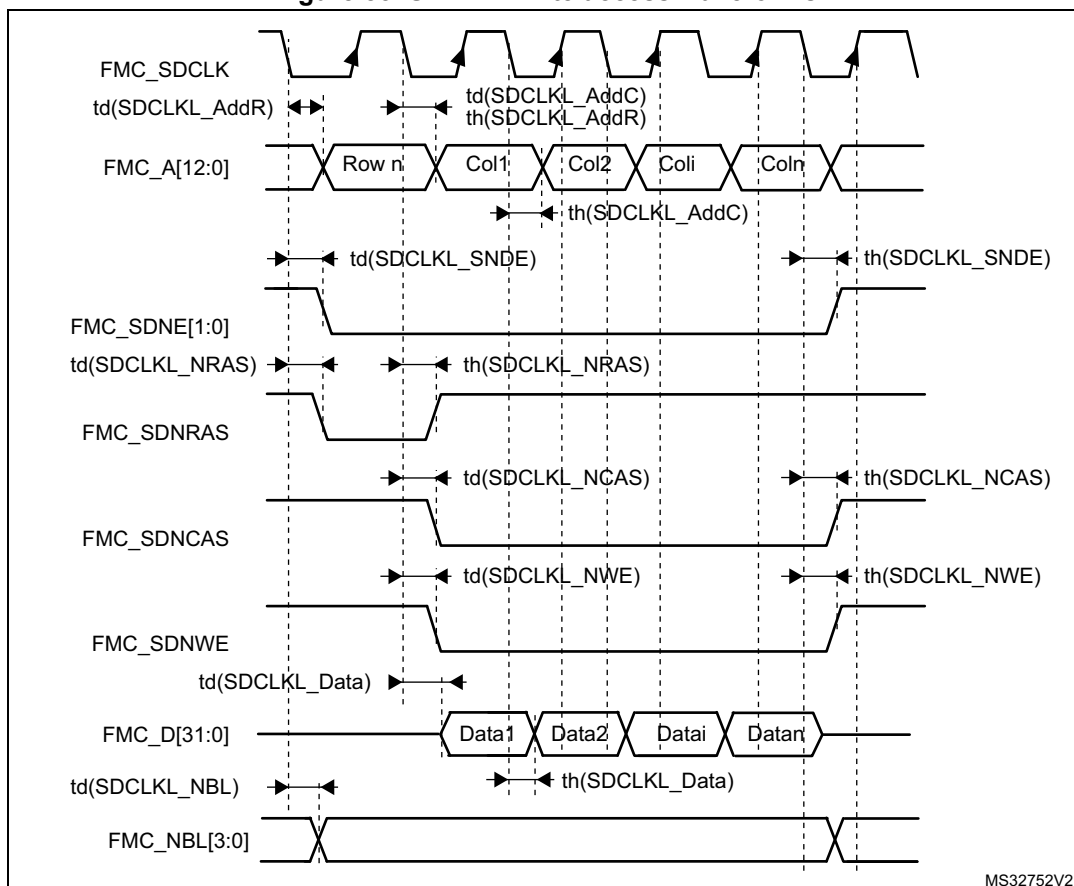

MS32752V2

Table 177. SDRAM Write timings<sup>(1)</sup>

Symbol	Parameter	Min	Max	Unit
$t_w(\text{SDCLK})$	FMC_SDCLK period	$2T_{\text{fmc\_ker\_ck}} - 1$	$2T_{\text{fmc\_ker\_ck}} + 0.5$	ns
$t_d(\text{SDCLKL\_Data})$	Data output valid time	-	1	
$t_h(\text{SDCLKL\_Data})$	Data output hold time	0	-	
$t_d(\text{SDCLKL\_Add})$	Address valid time	-	1.5	
$t_d(\text{SDCLKL\_SDNWE})$	SDNWE valid time	-	1.5	
$t_h(\text{SDCLKL\_SDNWE})$	SDNWE hold time	0.5	-	
$t_d(\text{SDCLKL\_SDNE})$	Chip select valid time	-	1.5	
$t_h(\text{SDCLKL\_SDNE})$	Chip select hold time	0.5	-	
$t_d(\text{SDCLKL\_SDNRAS})$	SDNRAS valid time	-	1	
$t_h(\text{SDCLKL\_SDNRAS})$	SDNRAS hold time	0.5	-	
$t_d(\text{SDCLKL\_SDNCAS})$	SDNCAS valid time	-	1	
$t_d(\text{SDCLKL\_SDNCAS})$	SDNCAS hold time	0.5	-	

1. Guaranteed by characterization results.



**Table 178. LPSDR SDRAM Write timings<sup>(1)</sup>**

Symbol	Parameter	Min	Max	Unit
$t_w(\text{SDCLK})$	FMC_SDCLK period	$2T_{\text{fmc\_ker\_ck}} - 1$	$2T_{\text{fmc\_ker\_ck}} + 0.5$	ns
$t_d(\text{SDCLKL\_Data})$	Data output valid time	-	2.5	
$t_h(\text{SDCLKL\_Data})$	Data output hold time	0	-	
$t_d(\text{SDCLKL\_Add})$	Address valid time	-	2.5	
$t_d(\text{SDCLKL-SDNWE})$	SDNWE valid time	-	2.5	
$t_h(\text{SDCLKL-SDNWE})$	SDNWE hold time	0	-	
$t_d(\text{SDCLKL-SDNE})$	Chip select valid time	-	3	
$t_h(\text{SDCLKL-SDNE})$	Chip select hold time	0	-	
$t_d(\text{SDCLKL-SDNRAS})$	SDNRAS valid time	-	1.5	
$t_h(\text{SDCLKL-SDNRAS})$	SDNRAS hold time	0	-	
$t_d(\text{SDCLKL-SDNCAS})$	SDNCAS valid time	-	1.5	
$t_d(\text{SDCLKL-SDNCAS})$	SDNCAS hold time	0	-	

1. Guaranteed by characterization results.

### 7.3.18 Quad-SPI interface characteristics

Unless otherwise specified, the parameters given in [Table 179](#) and [Table 180](#) for QUADSPI are derived from tests performed under the ambient temperature,  $f_{\text{AHB}}$  frequency and  $V_{\text{DD}}$  supply voltage conditions summarized in [Table 120: General operating conditions](#), with the following configuration:

- Output speed is set to  $\text{OSPEEDRy}[1:0] = 11$
- Measurement points are done at CMOS levels:  $0.5V_{\text{DD}}$
- IO Compensation cell activated.
- HSLV activated when  $V_{\text{DD}} \leq 2.7 \text{ V}$
- VOS level set to VOS1

Refer to [Section 7.3.15: I/O port characteristics](#) for more details on the input/output alternate function characteristics.

The following table summarizes the parameters measured in SDR mode.

**Table 179. QUADSPI characteristics in SDR mode<sup>(1)</sup>**

Symbol	Parameter	Conditions	Min	Typ	Max	Unit
$F_{\text{ck1}}/T_{\text{CK}}$	QUADSPI clock frequency	$2.7 < V_{\text{DD}} < 3.6 \text{ V}$ CL = 20 pF	-	-	133	MHz
		$1.62 < V_{\text{DD}} < 3.6 \text{ V}$ CL = 15 pF	-	-	100	

**Table 179. QUADSPI characteristics in SDR mode<sup>(1)</sup> (continued)**

Symbol	Parameter	Conditions	Min	Typ	Max	Unit
$t_{w(CKH)}$	QUADSPI clock high and low time Even division	PRESCALER[7:0] = n = 0,1,3,5...	$T_{CK}/2-0.5$	-	$T_{CK}/2$	ns
$t_{w(CKL)}$			$T_{CK}/2$	-	$T_{CK}/2+0.5$	
$t_{w(CKH)}$	QUADSPI clock high and low time Odd division	PRESCALER[7:0] = n = 2,4,6,8...	$(n/2)*T_{CK}/(n+1)-0.5$	-	$(n/2)*T_{CK}/(n+1)$	
$t_{w(CKL)}$			$(n/2+1)*T_{CK}/(n+1)$	-	$(n/2+1)*T_{CK}/(n+1)+0.5$	
$t_{s(IN)}$	Data input setup time	-	1	-	-	
$t_{h(IN)}$	Data input hold time	-	3.5	-	-	
$t_{v(OUT)}$	Data output valid time	-	-	1	2	
$t_{h(OUT)}$	Data output hold time	-	0	-	-	

1. Guaranteed by characterization results.

The following table summarizes the parameters measured in DDR mode.

**Table 180. QUADSPI characteristics in DDR mode<sup>(1)</sup>**

Symbol	Parameter	Conditions	Min	Typ	Max	Unit
$F_{ck1}/T_{CK}$	QUADSPI clock frequency	2.7<V <sub>DD</sub> <3.6 V CL = 20 pF	-	-	100	MHz
		1.62<V <sub>DD</sub> <3.6 V CL = 15 pF	-	-	100	
$t_{w(CKH)}$	QUADSPI clock high and low time Even division	PRESCALER[7:0] = n = 0,1,3,5...	$T_{CK}/2-0.5$	-	$T_{CK}/2$	ns
$t_{w(CKL)}$			$T_{CK}/2$	-	$T_{CK}/2+0.5$	
$t_{w(CKH)}$	QUADSPI clock high and low time Odd division	PRESCALER[7:0] = n = 2,4,6,8...	$(n/2)*T_{CK}/(n+1)-0.5$	-	$(n/2)*T_{CK}/(n+1)$	
$t_{w(CKL)}$			$(n/2+1)*T_{CK}/(n+1)$	-	$(n/2+1)*T_{CK}/(n+1)+0.5$	
$t_{sr(IN)}, t_{sf(IN)}$	Data input setup time	-	1.5	-	-	
$t_{hr(IN)}, t_{hf(IN)}$	Data input hold time	-	3.5	-	-	
$t_{vr(OUT)}, t_{vf(OUT)}$	Data output valid time	DHHC=0	-	5	6	
		DHHC=1 PRESCALER[7:0] = 1,2...	-	$T_{CK}/4+1$	$T_{CK}/4+2$	
$t_{hr(OUT)}, t_{hf(OUT)}$	Data output hold time	DHHC=0	3	-	-	
		DHHC=1 PRESCALER[7:0]=1,2...	$T_{CK}/4$	-	-	

1. Guaranteed by characterization results.

Figure 86. Quad-SPI timing diagram - SDR mode

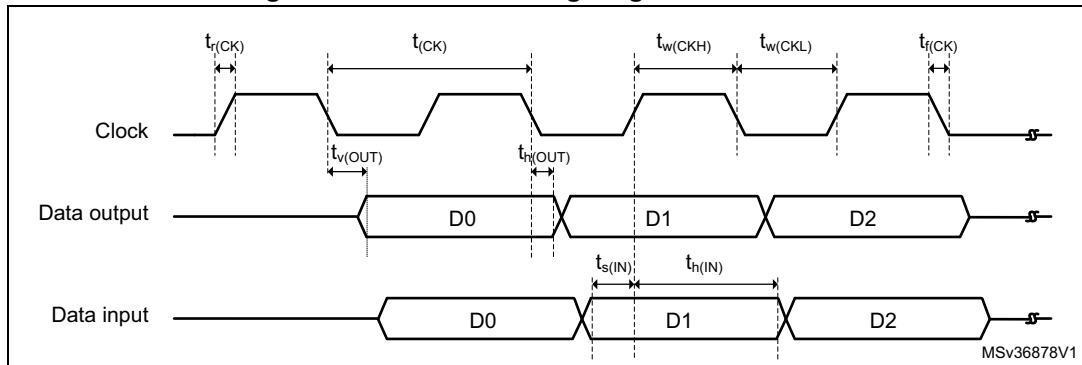
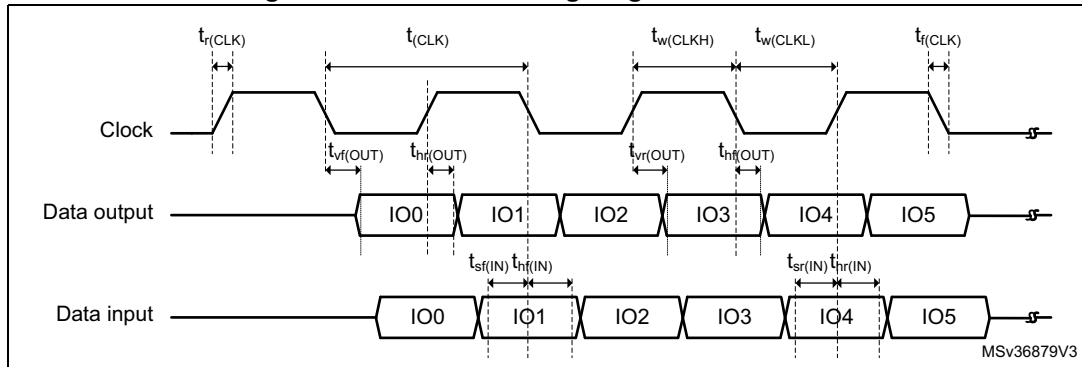

Figure 87. Quad-SPI timing diagram - DDR mode



### 7.3.19 Delay block (DLYB) characteristics

Unless otherwise specified, the parameters given in [Table 181](#) for Delay Block are derived from tests performed under the ambient temperature,  $f_{\text{rcc\_c\_ck}}$  frequency and VDD supply voltage summarized in [Table 120: General operating conditions](#), with the following configuration:

Table 181. Delay Block characteristics

Symbol	Parameter	Conditions	Min	Typ	Max	Unit
$t_{\text{init}}$	Initial delay	-	1400	2200	2400	ps
$t_{\Delta}$	Unit Delay	-	35	40	45	-

7.3.20 16-bit ADC characteristics

Unless otherwise specified, the parameters given in [Table 182](#) are derived from tests performed under the ambient temperature,  $f_{PCLK2}$  frequency and  $V_{DDA}$  supply voltage conditions summarized in [Table 120: General operating conditions](#).

Table 182. ADC characteristics<sup>(1)(2)</sup>

Symbol	Parameter	Conditions				Min	Typ	Max	Unit	
$V_{DDA}$	Analog supply voltage for ADC ON	-				1.62	-	3.6	V	
$V_{REF+}$	Positive reference voltage	-				1.62	-	$V_{DDA}$	V	
$V_{REF-}$	Negative reference voltage	-				$V_{SSA}$			V	
$f_{ADC}$	ADC clock frequency	$1.62\text{ V} \leq V_{DDA} \leq 3.6\text{ V}$				BOOST = 11	0.12	-	50	MHz
						BOOST = 10	0.12	-	25	
						BOOST = 01	0.12	-	12.5	
						BOOST = 00	-	-	6.25	
$f_s^{(3)}$	Sampling rate for Direct channels <sup>(4)</sup>	Resolution = 16 bits, $V_{DDA} > 2.5\text{ V}$	$T_J = 90\text{ }^\circ\text{C}$	$f_{ADC} = 36\text{ MHz}$	SMP = 1.5	-	-	3.60	MSps	
		Resolution = 16 bits		$f_{ADC} = 37\text{ MHz}$	SMP = 2.5	-	-	3.35		
		Resolution = 14 bits	$T_J = 125\text{ }^\circ\text{C}$	$f_{ADC} = 50\text{ MHz}$	SMP = 2.5	-	-	5.00		
		Resolution = 12 bits		$f_{ADC} = 50\text{ MHz}$	SMP = 2.5	-	-	5.50		
		Resolution = 10 bits		$f_{ADC} = 50\text{ MHz}$	SMP = 1.5	-	-	7.10		
		Resolution = 8 bits		$f_{ADC} = 50\text{ MHz}$	SMP = 1.5	-	-	8.30		
	Sampling rate for Fast channels	Resolution = 16 bits, $V_{DDA} > 2.5\text{ V}$	$T_J = 90\text{ }^\circ\text{C}$	$f_{ADC} = 32\text{ MHz}$	SMP = 2.5	-	-	2.90		
		Resolution = 16 bits		$f_{ADC} = 31\text{ MHz}$	SMP = 2.5	-	-	2.80		
		Resolution = 14 bits	$T_J = 125\text{ }^\circ\text{C}$	$f_{ADC} = 33\text{ MHz}$	SMP = 2.5	-	-	3.30		
		Resolution = 12 bits		$f_{ADC} = 39\text{ MHz}$	SMP = 2.5	-	-	4.30		
		Resolution = 10 bits		$f_{ADC} = 48\text{ MHz}$	SMP = 2.5	-	-	6.00		
		Resolution = 8 bits		$f_{ADC} = 50\text{ MHz}$	SMP = 2.5	-	-	7.10		
	Sampling rate for Slow channels	Resolution = 16 bits	$T_J = 90\text{ }^\circ\text{C}$	$f_{ADC} = 10\text{ MHz}$	SMP = 1.5	-	-	1.00		
		resolution = 14 bits				-	-			
		resolution = 12 bits	$T_J = 125\text{ }^\circ\text{C}$			-	-			
resolution = 10 bits		-				-				
resolution = 8 bits		-				-				
$t_{TRIG}$	External trigger period	Resolution = 16 bits				-	-	10	1/ $f_{ADC}$	
$V_{AIN}^{(5)}$	Conversion voltage range	-				0	-	$V_{REF+}$	V	
$V_{CMIV}$	Common mode input voltage	-				$V_{REF}/2 - 10\%$	$V_{REF}/2$	$V_{REF}/2 + 10\%$	V	

**Table 182. ADC characteristics<sup>(1)(2)</sup> (continued)**

Symbol	Parameter	Conditions			Min	Typ	Max	Unit
R <sub>AIN</sub> <sup>(6)</sup>	External input impedance	Resolution = 16 bits, T <sub>J</sub> = 125 °C	-	-	-	-	170	Ω
		Resolution = 14 bits, T <sub>J</sub> = 125 °C	-	-	-	-	435	
		Resolution = 12 bits, T <sub>J</sub> = 125 °C	-	-	-	-	1150	
		Resolution = 10 bits, T <sub>J</sub> = 125 °C	-	-	-	-	5650	
		Resolution = 8 bits, T <sub>J</sub> = 125 °C	-	-	-	-	26500	
C <sub>ADC</sub>	Internal sample and hold capacitor	-			-	4	-	pF
t <sub>ADCVREG_STUP</sub>	ADC LDO startup time	-			-	5	10	us
t <sub>STAB</sub>	ADC Power-up time	LDO already started			1	-	-	conversion cycle
t <sub>CAL</sub>	Offset and linearity calibration time	-			165010	-	-	1/f <sub>ADC</sub>
t <sub>OFF_CAL</sub>	Offset calibration time	-			1280	-	-	1/f <sub>ADC</sub>
t <sub>LATR</sub>	Trigger conversion latency regular and injected channels without conversion abort	CKMODE = 00			1.5	2	2.5	1/f <sub>ADC</sub>
		CKMODE = 01			-	-	2.5	
		CKMODE = 10			-	-	2.5	
		CKMODE = 11			-	-	2.25	
t <sub>LATRINJ</sub>	Trigger conversion latency regular injected channels aborting a regular conversion	CKMODE = 00			2.5	3	3.5	1/f <sub>ADC</sub>
		CKMODE = 01			-	-	3.5	
		CKMODE = 10			-	-	3.5	
		CKMODE = 11			-	-	3.25	
t <sub>S</sub>	Sampling time	-			1.5	-	810.5	1/f <sub>ADC</sub>
t <sub>CONV</sub>	Total conversion time (including sampling time)	Resolution = N bits			t <sub>s</sub> + 0.5 + N/2	-	-	1/f <sub>ADC</sub>

Table 182. ADC characteristics<sup>(1)(2)</sup> (continued)

Symbol	Parameter	Conditions			Min	Typ	Max	Unit
I <sub>DDA_D</sub> (ADC)	ADC consumption on V <sub>DDA</sub> , BOOST=11, Differential mode	Resolution = 16 bits, f <sub>ADC</sub> =25 MHz	-	-	-	1440	-	µA
		Resolution = 14 bits, f <sub>ADC</sub> =30 MHz	-	-	-	1350	-	
		Resolution = 12 bits, f <sub>ADC</sub> =40 MHz	-	-	-	990	-	
	ADC consumption on V <sub>DDA</sub> , BOOST=10, Differential mode f <sub>ADC</sub> =25 MHz	Resolution = 16 bits	-	-	-	1080	-	
		Resolution = 14 bits	-	-	-	810	-	
		Resolution = 12 bits	-	-	-	585	-	
	ADC consumption on V <sub>DDA</sub> , BOOST=01, Differential mode f <sub>ADC</sub> =12.5 MHz	Resolution = 16 bits	-	-	-	630	-	
		Resolution = 14 bits	-	-	-	432	-	
		Resolution = 12 bits	-	-	-	315	-	
	ADC consumption on V <sub>DDA</sub> , BOOST=00, Differential mode f <sub>ADC</sub> =6.25 MHz	Resolution = 16 bits	-	-	-	360	-	
		Resolution = 14 bits	-	-	-	270	-	
		Resolution = 12 bits	-	-	-	225	-	
I <sub>DDA_SE</sub> (ADC)	ADC consumption on V <sub>DDA</sub> , BOOST=11, Single-ended mode	Resolution = 16 bits, f <sub>ADC</sub> =25 MHz	-	-	-	720	-	
		Resolution = 14 bits, f <sub>ADC</sub> =30 MHz	-	-	-	675	-	
		Resolution = 12 bits, f <sub>ADC</sub> =40 MHz	-	-	-	495	-	
	ADC consumption on V <sub>DDA</sub> , BOOST=10, Single-ended mode f <sub>ADC</sub> =25 MHz	Resolution = 16 bits	-	-	-	540	-	
		Resolution = 14 bits	-	-	-	405	-	
		Resolution = 12 bits	-	-	-	292.5	-	
	ADC consumption on V <sub>DDA</sub> , BOOST=01, Single-ended mode f <sub>ADC</sub> =12.5 MHz	Resolution = 16 bits	-	-	-	315	-	
		Resolution = 14 bits	-	-	-	216	-	
		Resolution = 12 bits	-	-	-	157.5	-	
	ADC consumption on V <sub>DDA</sub> , BOOST=00, Single-ended mode f <sub>ADC</sub> =6.25 MHz	Resolution = 16 bits	-	-	-	180	-	
		Resolution = 14 bits	-	-	-	135	-	
		Resolution = 12 bits	-	-	-	112.5	-	
I <sub>DD</sub> (ADC)	ADC consumption on V <sub>DD</sub>	f <sub>ADC</sub> =50 MHz	-	-	-	400	-	
		f <sub>ADC</sub> =25 MHz	-	-	-	220	-	
		f <sub>ADC</sub> =12.5 MHz	-	-	-	180	-	
		f <sub>ADC</sub> =6.25 MHz	-	-	-	120	-	
		f <sub>ADC</sub> =3.125 MHz	-	-	-	80	-	

1. Guaranteed by design.
2. The voltage booster on ADC switches must be used for V<sub>DDA</sub> < 2.4 V (embedded I/O switches).
3. These values are valid for UFBGA176+25 and one ADC. The values for other packages and multiple ADCs may be different.
4. Direct channels are connected to analog I/Os (PA0\_C, PA1\_C, PC2\_C and PC3\_C) to optimize ADC performance.
5. Depending on the package, V<sub>REF+</sub> can be internally connected to V<sub>DDA</sub> and V<sub>REF-</sub> to V<sub>SSA</sub>.
6. The tolerance is 10 LSBs for 16-bit resolution, 4 LSBs for 14-bit resolution, and 2 LSBs for 12-bit, 10-bit and 8-bit resolutions.

Table 183. Minimum sampling time vs  $R_{AIN}^{(1)(2)}$

Resolution	RAIN ( $\Omega$ )	Minimum sampling time (s)		
		Direct channels <sup>(3)</sup>	Fast channels <sup>(4)</sup>	Slow channels <sup>(5)</sup>
16 bits	47	7.37E-08	1.14E-07	1.72E-07
14 bits	47	6.29E-08	9.74E-08	1.55E-07
	68	6.84E-08	1.02E-07	1.58E-07
	100	7.80E-08	1.12E-07	1.62E-07
	150	9.86E-08	1.32E-07	1.80E-07
	220	1.32E-07	1.61E-07	2.01E-07
12 bits	47	5.32E-08	8.00E-08	1.29E-07
	68	5.74E-08	8.50E-08	1.32E-07
	100	6.58E-08	9.31E-08	1.40E-07
	150	8.37E-08	1.10E-07	1.51E-07
	220	1.11E-07	1.34E-07	1.73E-07
	330	1.56E-07	1.78E-07	2.14E-07
	470	2.16E-07	2.39E-07	2.68E-07
	680	3.01E-07	3.29E-07	3.54E-07
10 bits	47	4.34E-08	6.51E-08	1.08E-07
	68	4.68E-08	6.89E-08	1.11E-07
	100	5.35E-08	7.55E-08	1.16E-07
	150	6.68E-08	8.77E-08	1.26E-07
	220	8.80E-08	1.08E-07	1.40E-07
	330	1.24E-07	1.43E-07	1.71E-07
	470	1.69E-07	1.89E-07	2.13E-07
	680	2.38E-07	2.60E-07	2.80E-07
	1000	3.45E-07	3.66E-07	3.84E-07
	1500	5.15E-07	5.35E-07	5.48E-07
	2200	7.42E-07	7.75E-07	7.78E-07
	3300	1.10E-06	1.14E-06	1.14E-06

**Table 183. Minimum sampling time vs  $R_{AIN}^{(1)(2)}$  (continued)**

Resolution	RAIN ( $\Omega$ )	Minimum sampling time (s)		
		Direct channels <sup>(3)</sup>	Fast channels <sup>(4)</sup>	Slow channels <sup>(5)</sup>
8 bits	47	3.32E-08	5.10E-08	8.61E-08
	68	3.59E-08	5.35E-08	8.83E-08
	100	4.10E-08	5.83E-08	9.22E-08
	150	5.06E-08	6.76E-08	9.95E-08
	220	6.61E-08	8.22E-08	1.11E-07
	330	9.17E-08	1.08E-07	1.32E-07
	470	1.24E-07	1.40E-07	1.63E-07
	680	1.74E-07	1.91E-07	2.12E-07
	1000	2.53E-07	2.70E-07	2.85E-07
	1500	3.73E-07	3.93E-07	4.05E-07
	2200	5.39E-07	5.67E-07	5.75E-07
	3300	8.02E-07	8.36E-07	8.38E-07
	4700	1.13E-06	1.18E-06	1.18E-06
	6800	1.62E-06	1.69E-06	1.68E-06
	10000	2.36E-06	2.47E-06	2.45E-06
15000	3.50E-06	3.69E-06	3.65E-06	

1. Guaranteed by design.
2. Data valid at up to 125 °C, with a 47 pF PCB capacitor, and  $V_{DDA}=1.6$  V.
3. Direct channels are connected to analog I/Os (PA0\_C, PA1\_C, PC2\_C and PC3\_C) to optimize ADC performance.
4. Fast channels correspond to PF3, PF5, PF7, PF9, PA6, PC4, PB1, PF11 and PF13.
5. Slow channels correspond to all ADC inputs except for the Direct and Fast channels.



Table 184. ADC accuracy<sup>(1)(2)</sup>

Symbol	Parameter	Conditions <sup>(3)</sup>		Min	Typ	Max	Unit
ET	Total undadjusted error	Direct channel	Single ended	-	+10/-20	-	LSB
			Differential	-	±15	-	
		Fast channel	Single ended	-	+10/-20	-	
			Differential	-	±15	-	
		Slow channel	Single ended	-	±10	-	
			Differential	-	±10	-	
EO	Offset error	-		-	±10	-	LSB
EG	Gain error	-		-	±15	-	
ED	Differential linearity error	Single ended		-	+3/-1	-	
		Differential		-	+4.5/-1	-	
EL	Integral linearity error	Direct channel	Single ended	-	±11	-	LSB
			Differential	-	±7	-	
		Fast channel	Single ended	-	±13	-	
			Differential	-	±7	-	
		Slow channel	Single ended	-	±10	-	
			Differential	-	±6	-	
ENOB	Effective number of bits	Single ended		-	12.2	-	Bits
		Differential		-	13.2	-	
SINAD	Signal-to-noise and distortion ratio	Single ended		-	75.2	-	dB
		Differential		-	81.2	-	
SNR	Signal-to-noise ratio	Single ended		-	77.0	-	
		Differential		-	81.0	-	
THD	Total harmonic distortion	Single ended		-	87	-	
		Differential		-	90	-	

1. Data guaranteed by characterization for BGA packages. The values for LQFP packages might differ.
2. ADC DC accuracy values are measured after internal calibration.
3. ADC clock frequency = 25 MHz, ADC resolution = 16 bits,  $V_{DDA}=V_{REF+}=3.3\text{ V}$  and BOOST=11.

Note: ADC accuracy vs. negative injection current: injecting a negative current on any analog input pins should be avoided as this significantly reduces the accuracy of the conversion being performed on another analog input. It is recommended to add a Schottky diode (pin to ground) to analog pins which may potentially inject negative currents.

Any positive injection current within the limits specified for  $I_{INJ(PIN)}$  and  $\sum I_{INJ(PIN)}$  in [Section 7.3.14](#) does not affect the ADC accuracy.

Figure 88. ADC accuracy characteristics (12-bit resolution)

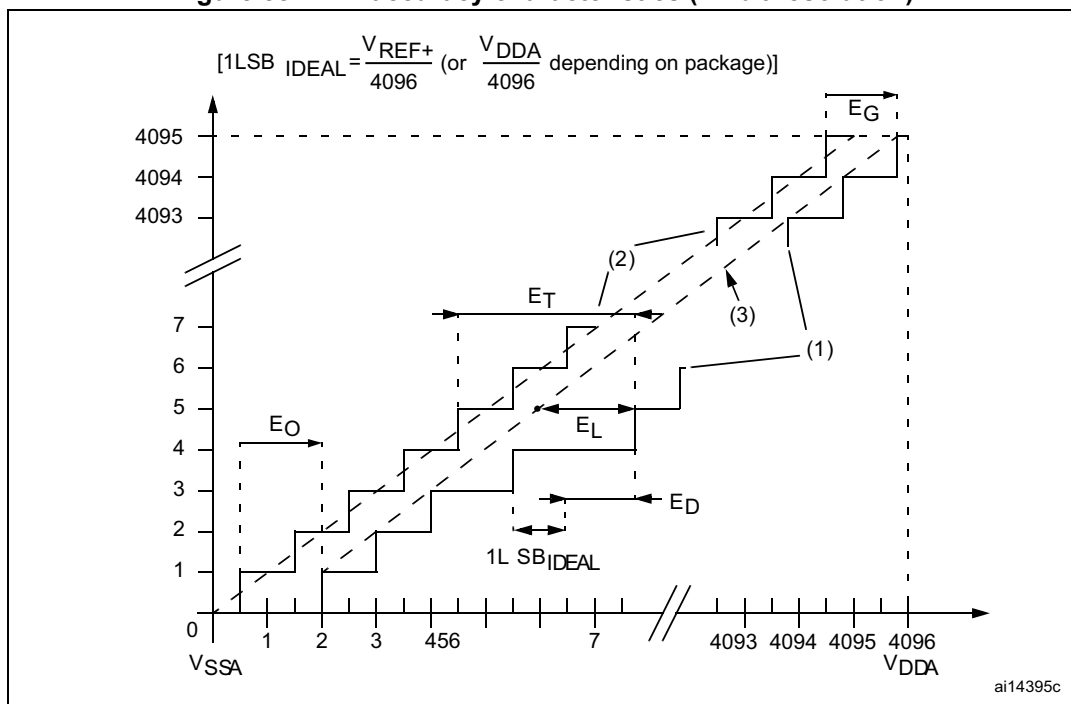

1. Example of an actual transfer curve.
2. Ideal transfer curve.
3. End point correlation line.
4.  $E_T$  = Total Unadjusted Error: maximum deviation between the actual and the ideal transfer curves.  
 $E_O$  = Offset Error: deviation between the first actual transition and the first ideal one.  
 $E_G$  = Gain Error: deviation between the last ideal transition and the last actual one.  
 $E_D$  = Differential Linearity Error: maximum deviation between actual steps and the ideal one.  
 $E_L$  = Integral Linearity Error: maximum deviation between any actual transition and the end point correlation line.

Figure 89. Typical connection diagram using the ADC

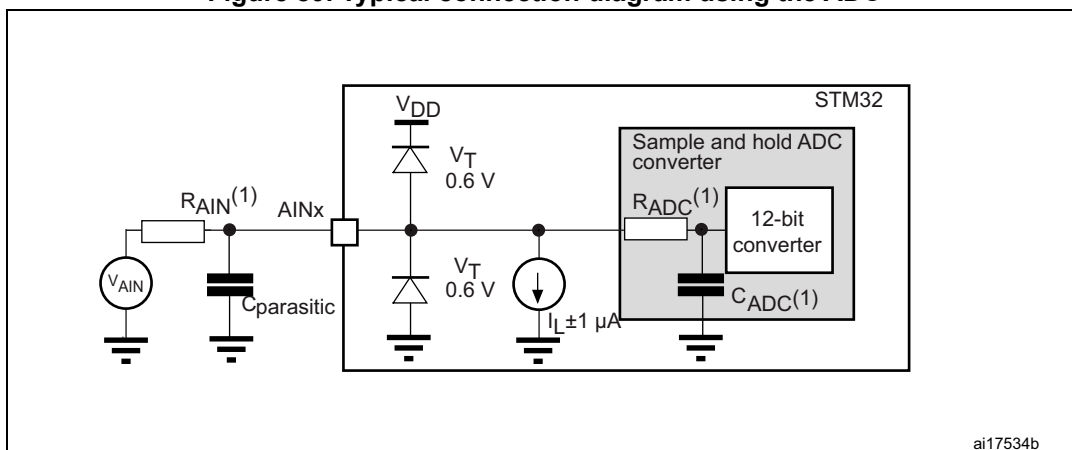

1. Refer to [Table 182](#) for the values of  $R_{AIN}$ ,  $R_{ADC}$  and  $C_{ADC}$ .
2.  $C_{parasitic}$  represents the capacitance of the PCB (dependent on soldering and PCB layout quality) plus the pad capacitance (roughly 5 pF). A high  $C_{parasitic}$  value downgrades conversion accuracy. To remedy this,  $f_{ADC}$  should be reduced.

**General PCB design guidelines**

Power supply decoupling should be performed as shown in [Figure 90](#) or [Figure 91](#), depending on whether  $V_{REF+}$  is connected to  $V_{DDA}$  or not. The 100 nF capacitors should be ceramic (good quality). They should be placed them as close as possible to the chip.

**Figure 90. Power supply and reference decoupling ( $V_{REF+}$  not connected to  $V_{DDA}$ )**

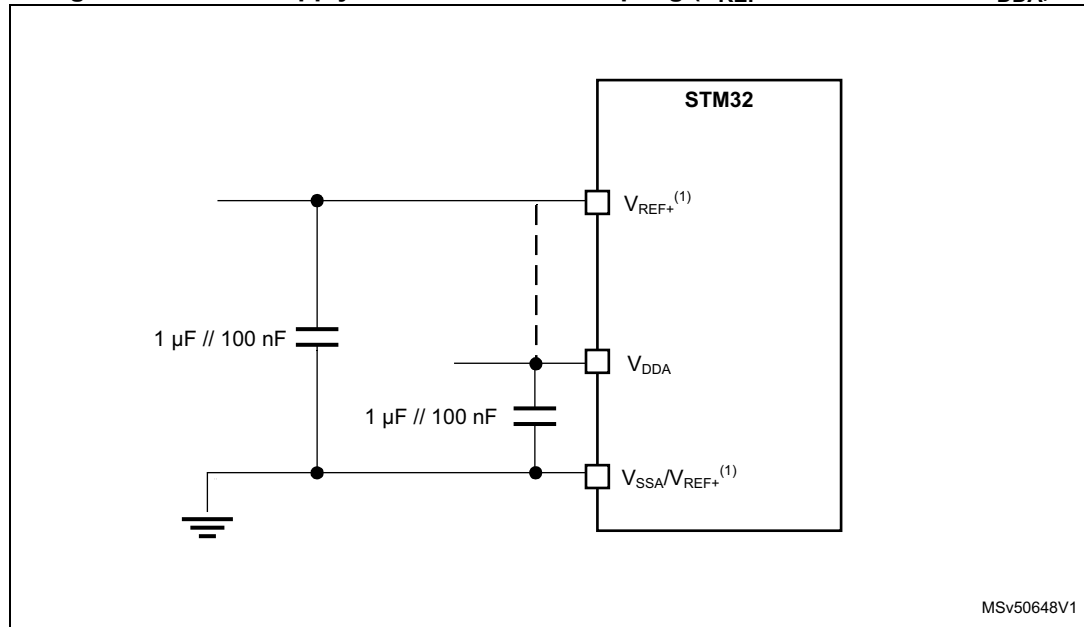

1.  $V_{REF+}$  input is available on all package whereas the  $V_{REF-}$  s available only on UFBGA176+25 and TFBGA240+25. When  $V_{REF-}$  is not available, it is internally connected to  $V_{DDA}$  and  $V_{SSA}$ .

**Figure 91. Power supply and reference decoupling ( $V_{REF+}$  connected to  $V_{DDA}$ )**

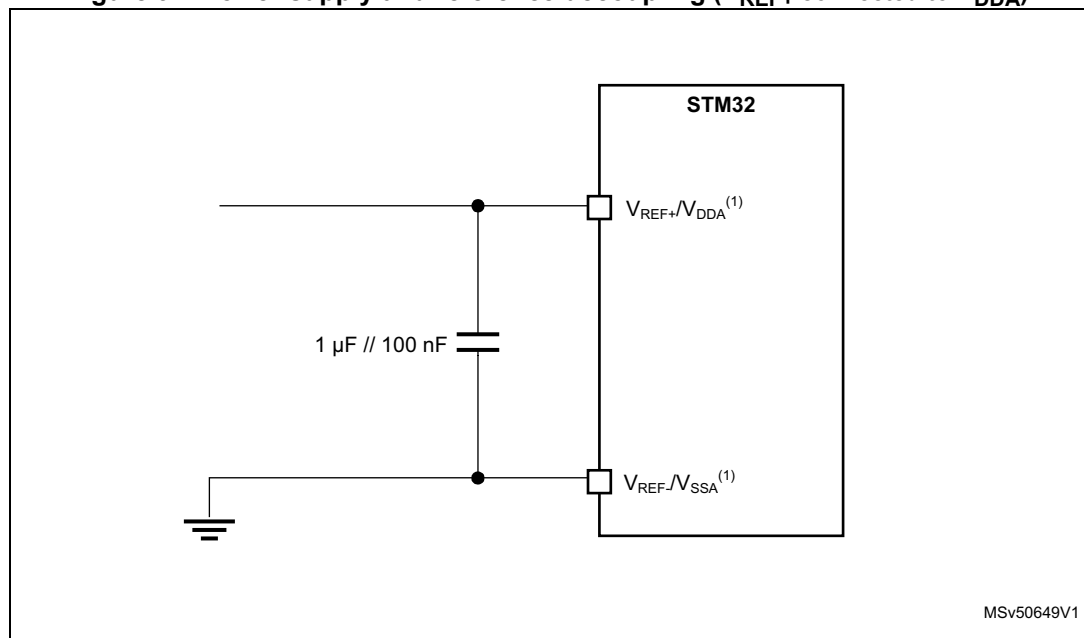

1.  $V_{REF+}$  input is available on all package whereas the  $V_{REF-}$  s available only on UFBGA176+25 and TFBGA240+25. When  $V_{REF-}$  is not available, it is internally connected to  $V_{DDA}$  and  $V_{SSA}$ .

## 7.3.21 DAC characteristics

Table 185. DAC characteristics<sup>(1)(2)</sup>

Symbol	Parameter	Conditions	Min	Typ	Max	Unit	
$V_{DDA}$	Analog supply voltage	-	1.8	3.3	3.6	V	
$V_{REF+}$	Positive reference voltage	-	1.80	-	$V_{DDA}$		
$V_{REF-}$	Negative reference voltage	-	-	$V_{SSA}$	-		
$R_L$	Resistive Load	DAC output buffer ON	connected to $V_{SSA}$	5	-	-	k $\Omega$
			connected to $V_{DDA}$	25	-	-	
$R_O$	Output Impedance	DAC output buffer OFF	10.3	13	16		
$R_{BON}$	Output impedance sample and hold mode, output buffer ON	DAC output buffer ON	$V_{DD} = 2.7\text{ V}$	-	-	1.6	k $\Omega$
			$V_{DD} = 2.0\text{ V}$	-	-	2.6	
$R_{BOFF}$	Output impedance sample and hold mode, output buffer OFF	DAC output buffer OFF	$V_{DD} = 2.7\text{ V}$	-	-	17.8	k $\Omega$
			$V_{DD} = 2.0\text{ V}$	-	-	18.7	
$C_L$	Capacitive Load	DAC output buffer OFF	-	-	50	pF	
$C_{SH}$		Sample and Hold mode	-	0.1	1	$\mu\text{F}$	
$V_{DAC\_OUT}$	Voltage on DAC_OUT output	DAC output buffer ON	0.2	-	$V_{DDA} - 0.2$	V	
		DAC output buffer OFF	0	-	$V_{REF+}$		
$t_{SETTLING}$	Settling time (full scale: for a 12-bit code transition between the lowest and the highest input codes when DAC_OUT reaches the final value of $\pm 0.5\text{LSB}$ , $\pm 1\text{LSB}$ , $\pm 2\text{LSB}$ , $\pm 4\text{LSB}$ , $\pm 8\text{LSB}$ )	Normal mode, DAC output buffer ON, $C_L \leq 50\text{ pF}$ , $R_L \geq 5\text{ ?}$	$\pm 0.5\text{ LSB}$	-	2.05	-	$\mu\text{s}$
			$\pm 1\text{ LSB}$	-	1.97	-	
			$\pm 2\text{ LSB}$	-	1.67	-	
			$\pm 4\text{ LSB}$	-	1.66	-	
			$\pm 8\text{ LSB}$	-	1.65	-	
		Normal mode, DAC output buffer OFF, $\pm 1\text{LSB}$ $C_L = 10\text{ pF}$	-	1.7	2		
$t_{WAKEUP}^{(3)}$	Wakeup time from off state (setting the ENx bit in the DAC Control register) until the final value of $\pm 1\text{LSB}$ is reached	Normal mode, DAC output buffer ON, $C_L \leq 50\text{ pF}$ , $R_L = 5\text{ ?}$	-	5	7.5	$\mu\text{s}$	
		Normal mode, DAC output buffer OFF, $C_L \leq 10\text{ pF}$	-	2	5		
PSRR	DC $V_{DDA}$ supply rejection ratio	Normal mode, DAC output buffer ON, $C_L \leq 50\text{ pF}$ , $R_L = 5\text{ ?}$	-	-80	-28	dB	

Table 185. DAC characteristics<sup>(1)(2)</sup> (continued)

Symbol	Parameter	Conditions	Min	Typ	Max	Unit	
t <sub>SAMP</sub>	Sampling time in Sample and Hold mode C <sub>L</sub> =100 nF (code transition between the lowest input code and the highest input code when DAC_OUT reaches the ±1LSB final value)	MODE<2:0>_V12=100/101 (BUFFER ON)	-	0.7	2.6	ms	
		MODE<2:0>_V12=110 (BUFFER OFF)	-	11.5	18.7		
		MODE<2:0>_V12=111 (INTERNAL BUFFER OFF)	-	0.3	0.6	µs	
C <sub>lint</sub>	Internal sample and hold capacitor	-	1.8	2.2	2.6	pF	
t <sub>TRIM</sub>	Middle code offset trim time	Minimum time to verify the each code	50	-	-	µs	
V <sub>offset</sub>	Middle code offset for 1 trim code step	V <sub>REF+</sub> = 3.6 V	-	850	-	µV	
		V <sub>REF+</sub> = 1.8 V	-	425	-		
I <sub>DDA(DAC)</sub>	DAC quiescent consumption from V <sub>DDA</sub>	DAC output buffer ON	No load, middle code (0x800)	-	360	-	µA
			No load, worst code (0xF1C)	-	490	-	
		DAC output buffer OFF	No load, middle/worst code (0x800)	-	20	-	
		Sample and Hold mode, C <sub>SH</sub> =100 nF	-	360*T <sub>ON</sub> / (T <sub>ON</sub> +T <sub>OFF</sub> ) <sup>(4)</sup>	-		
I <sub>DDV(DAC)</sub>	DAC consumption from V <sub>REF+</sub>	DAC output buffer ON	No load, middle code (0x800)	-	170	-	µA
			No load, worst code (0xF1C)	-	170	-	
		DAC output buffer OFF	No load, middle/worst code (0x800)	-	160	-	
		Sample and Hold mode, Buffer ON, C <sub>SH</sub> =100 nF (worst code)	-	170*T <sub>ON</sub> / (T <sub>ON</sub> +T <sub>OFF</sub> ) <sup>(4)</sup>	-		
		Sample and Hold mode, Buffer OFF, C <sub>SH</sub> =100 nF (worst code)	-	160*T <sub>ON</sub> / (T <sub>ON</sub> +T <sub>OFF</sub> ) <sup>(4)</sup>	-		

1. Guaranteed by design unless otherwise specified.



2. TBD stands for "to be defined".
3. In buffered mode, the output can overshoot above the final value for low input code (starting from the minimum value).
4.  $T_{ON}$  is the refresh phase duration, while  $T_{OFF}$  is the hold phase duration. Refer to the product reference manual for more details.

**Table 186. DAC accuracy<sup>(1)</sup>**

Symbol	Parameter	Conditions	Min	Typ	Max	Unit	
DNL	Differential non linearity <sup>(2)</sup>	DAC output buffer ON	-2	-	2	LSB	
		DAC output buffer OFF	-2	-	2		
-	Monotonicity	10 bits	-	-	-	-	
INL	Integral non linearity <sup>(3)</sup>	DAC output buffer ON, $C_L \leq 50$ pF, $R_L \geq 5 \text{ ?}$	-4	-	4	LSB	
		DAC output buffer OFF, $C_L \leq 50$ pF, no $R_L$	-4	-	4		
Offset	Offset error at code 0x800 <sup>(3)</sup>	DAC output buffer ON, $C_L \leq 50$ pF, $R_L \geq 5 \text{ ?}$	$V_{REF+} = 3.6$ V	-	-	$\pm 15$	LSB
			$V_{REF+} = 1.8$ V	-	-	$\pm 30$	
		DAC output buffer OFF, $C_L \leq 50$ pF, no $R_L$	-	-	$\pm 8$		
Offset1	Offset error at code 0x001 <sup>(4)</sup>	DAC output buffer OFF, $C_L \leq 50$ pF, no $R_L$	-	-	$\pm 5$	LSB	
OffsetCal	Offset error at code 0x800 after factory calibration	DAC output buffer ON, $C_L \leq 50$ pF, $R_L \geq 5 \text{ ?}$	$V_{REF+} = 3.6$ V	-	-	$\pm 6$	LSB
			$V_{REF+} = 1.8$ V	-	-	$\pm 7$	
Gain	Gain error <sup>(5)</sup>	DAC output buffer ON, $C_L \leq 50$ pF, $R_L \geq 5 \text{ ?}$	-	-	$\pm 1$	%	
		DAC output buffer OFF, $C_L \leq 50$ pF, no $R_L$	-	-	$\pm 1$		
SNR	Signal-to-noise ratio <sup>(6)</sup>	DAC output buffer ON, $C_L \leq 50$ pF, $R_L \geq 5 \text{ ?}$ , 1 kHz, BW = 500 KHz	-	67.8	-	dB	
		DAC output buffer OFF, $C_L \leq 50$ pF, no $R_L$ , 1 kHz, BW = 500 KHz	-	67.8	-		
THD	Total harmonic distortion <sup>(6)</sup>	DAC output buffer ON, $C_L \leq 50$ pF, $R_L \geq 5 \text{ ?}$ , 1 kHz	-	-78.6	-	dB	
		DAC output buffer OFF, $C_L \leq 50$ pF, no $R_L$ , 1 kHz	-	-78.6	-		
SINAD	Signal-to-noise and distortion ratio <sup>(6)</sup>	DAC output buffer ON, $C_L \leq 50$ pF, $R_L \geq 5 \text{ ?}$ , 1 kHz	-	67.5	-	dB	
		DAC output buffer OFF, $C_L \leq 50$ pF, no $R_L$ , 1 kHz	-	67.5	-		

Table 186. DAC accuracy<sup>(1)</sup> (continued)

Symbol	Parameter	Conditions	Min	Typ	Max	Unit
ENOB	Effective number of bits	DAC output buffer ON, $C_L \leq 50$ pF, $R_L \geq 5 \text{ ?}$ , 1 kHz	-	10.9	-	bits
		DAC output buffer OFF, $C_L \leq 50$ pF, no $R_L$ , 1 kHz	-	10.9	-	

1. Guaranteed by characterization.
2. Difference between two consecutive codes minus 1 LSB.
3. Difference between the value measured at Code *i* and the value measured at Code *i* on a line drawn between Code 0 and last Code 4095.
4. Difference between the value measured at Code (0x001) and the ideal value.
5. Difference between the ideal slope of the transfer function and the measured slope computed from code 0x000 and 0xFFFF when the buffer is OFF, and from code giving 0.2 V and ( $V_{REF+} - 0.2$  V) when the buffer is ON.
6. Signal is -0.5dBFS with  $F_{\text{sampling}}=1$  MHz.

Figure 92. 12-bit buffered /non-buffered DAC

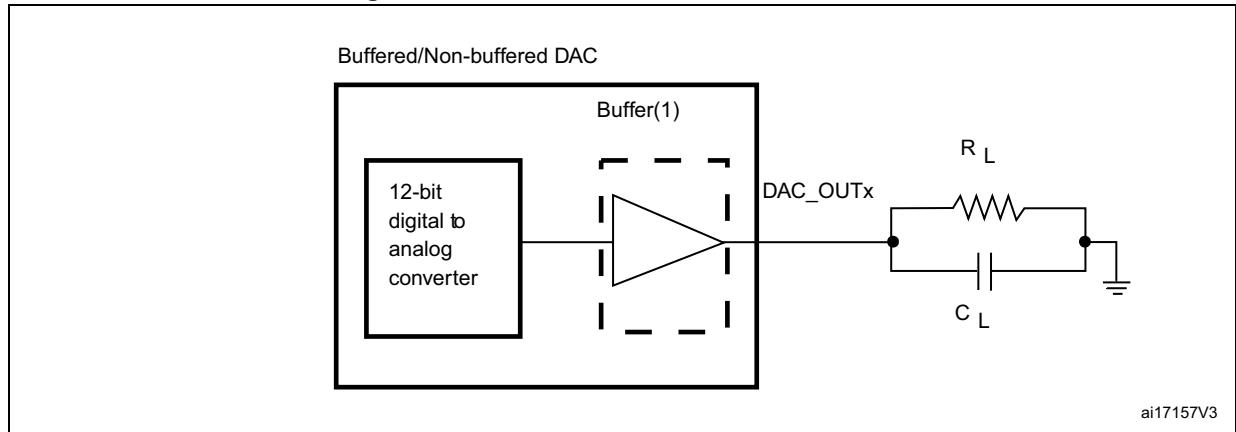

1. The DAC integrates an output buffer that can be used to reduce the output impedance and to drive external loads directly without the use of an external operational amplifier. The buffer can be bypassed by configuring the BOFFx bit in the DAC\_CR register.

## 7.3.22 Voltage reference buffer characteristics

Table 187. VREFBUF characteristics<sup>(1)</sup>

Symbol	Parameter	Conditions		Min	Typ	Max	Unit
V <sub>DDA</sub>	Analog supply voltage	Normal mode	VSCALE = 000	2.8	3.3	3.6	V
			VSCALE = 001	2.4	-	3.6	
			VSCALE = 010	2.1	-	3.6	
			VSCALE = 011	1.8	-	3.6	
		Degraded mode	VSCALE = 000	1.62	-	2.80	
			VSCALE = 001	1.62	-	2.40	
			VSCALE = 010	1.62	-	2.10	
			VSCALE = 011	1.62	-	1.80	
V <sub>REFBUF_OUT</sub>	Voltage Reference Buffer Output, at 30 °C, I <sub>load</sub> = 100 µA	Normal mode	VSCALE = 000	2.498	2.5	2.5035	V
			VSCALE = 001	2.046	2.049	2.052	
			VSCALE = 010	1.801	1.804	1.806	
			VSCALE = 011	1.4995	1.5015	1.504	
		Degraded mode <sup>(2)</sup>	VSCALE = 000	V <sub>DDA</sub> - 150 mV	-	V <sub>DDA</sub>	
			VSCALE = 001	V <sub>DDA</sub> - 150 mV	-	V <sub>DDA</sub>	
			VSCALE = 010	V <sub>DDA</sub> - 150 mV	-	V <sub>DDA</sub>	
			VSCALE = 011	V <sub>DDA</sub> - 150 mV	-	V <sub>DDA</sub>	
TRIM	Trim step resolution	-	-	-	±0.05	±0.1	%
C <sub>L</sub>	Load capacitor	-	-	0.5	1	1.50	µF
esr	Equivalent Serial Resistor of C <sub>L</sub>	-	-	-	-	2	?
I <sub>load</sub>	Static load current	-	-	-	-	4	mA
I <sub>line_reg</sub>	Line regulation	2.8 V ≤ V <sub>DDA</sub> ≤ 3.6 V	I <sub>load</sub> = 500 µA	-	200	-	ppm/V
			I <sub>load</sub> = 4 mA	-	100	-	
I <sub>load_reg</sub>	Load regulation	500 µA ≤ I <sub>LOAD</sub> ≤ 4 mA	Normal Mode	-	50	-	ppm/mA
T <sub>coeff</sub>	Temperature coefficient	-40 °C < T <sub>J</sub> < +125 °C		-	-	T <sub>coeff</sub> V <sub>REFINT</sub> + 100	ppm/°C
PSRR	Power supply rejection	DC	-	-	60	-	dB
		100KHz	-	-	40	-	



**Table 187. VREFBUF characteristics<sup>(1)</sup> (continued)**

Symbol	Parameter	Conditions		Min	Typ	Max	Unit
t <sub>START</sub>	Start-up time	C <sub>L</sub> =0.5 μF	-	-	300	-	μs
		C <sub>L</sub> =1 μF	-	-	500	-	
		C <sub>L</sub> =1.5 μF	-	-	650	-	
I <sub>INRUSH</sub>	Control of maximum DC current drive on V <sub>REFBUF_OUT</sub> during startup phase <sup>(3)</sup>	-		-	8	-	mA
I <sub>DDA(VREFBUF)</sub>	VREFBUF consumption from V <sub>DDA</sub>	I <sub>LOAD</sub> = 0 μA	-	-	15	25	μA
		I <sub>LOAD</sub> = 500 μA	-	-	16	30	
		I <sub>LOAD</sub> = 4 mA	-	-	32	50	

1. Guaranteed by design.
2. In degraded mode, the voltage reference buffer cannot accurately maintain the output voltage (V<sub>DDA</sub>-drop voltage).
3. To properly control VREFBUF I<sub>INRUSH</sub> current during the startup phase and the change of scaling, V<sub>DDA</sub> voltage should be in the range of 1.8 V-3.6 V, 2.1 V-3.6 V, 2.4 V-3.6 V and 2.8 V-3.6 V for VSCALE = 011, 010, 001 and 000, respectively.

### 7.3.23 Temperature sensor characteristics

**Table 188. Temperature sensor characteristics**

Symbol	Parameter	Min	Typ	Max	Unit
T <sub>L</sub> <sup>(1)</sup>	V <sub>SENSE</sub> linearity with temperature	-	-	3	°C
Avg_Slope <sup>(2)</sup>	Average slope	-	2	-	mV/°C
V <sub>30</sub> <sup>(3)</sup>	Voltage at 30°C ± 5 °C	-	0.62	-	V
t <sub>start_run</sub>	Startup time in Run mode (buffer startup)	-	-	25.2	μs
t <sub>S_temp</sub> <sup>(1)</sup>	ADC sampling time when reading the temperature	9	-	-	
I <sub>sens</sub> <sup>(1)</sup>	Sensor consumption	-	0.18	0.31	μA
I <sub>sensbuf</sub> <sup>(1)</sup>	Sensor buffer consumption	-	3.8	6.5	

1. Guaranteed by design.
2. Guaranteed by characterization.
3. Measured at V<sub>DDA</sub> = 3.3 V ± 10 mV. The V<sub>30</sub> ADC conversion result is stored in the TS\_CAL1 byte.

**Table 189. Temperature sensor calibration values**

Symbol	Parameter	Memory address
TS_CAL1	Temperature sensor raw data acquired value at 30 °C, V <sub>DDA</sub> =3.3 V	0x1FF1 E820 - 0x1FF1 E821
TS_CAL2	Temperature sensor raw data acquired value at 110 °C, V <sub>DDA</sub> =3.3 V	0x1FF1 E840 - 0x1FF1 E841

### 7.3.24 Temperature and $V_{BAT}$ monitoring

**Table 190.  $V_{BAT}$  monitoring characteristics**

Symbol	Parameter	Min	Typ	Max	Unit
R	Resistor bridge for $V_{BAT}$	-	26	-	K $\Omega$
Q	Ratio on $V_{BAT}$ measurement	-	4	-	-
$Er^{(1)}$	Error on Q	-10	-	+10	%
$t_{S\_vbat}^{(1)}$	ADC sampling time when reading $V_{BAT}$ input	9	-	-	$\mu s$
$V_{BAThigh}$	High supply monitoring	-	3.55	-	V
$V_{BATlow}$	Low supply monitoring	-	1.36	-	

1. Guaranteed by design.

**Table 191.  $V_{BAT}$  charging characteristics**

Symbol	Parameter	Condition	Min	Typ	Max	Unit
$R_{BC}$	Battery charging resistor	VBRS in PWR_CR3= 0	-	5	-	K $\Omega$
		VBRS in PWR_CR3= 1		1.5	-	

**Table 192. Temperature monitoring characteristics**

Symbol	Parameter	Min	Typ	Max	Unit
$TEMP_{high}$	High temperature monitoring	-	117	-	$^{\circ}C$
$TEMP_{low}$	Low temperature monitoring	-	-25	-	

### 7.3.25 Voltage booster for analog switch

**Table 193. Voltage booster for analog switch characteristics<sup>(1)</sup>**

Symbol	Parameter	Condition	Min	Typ	Max	Unit
$V_{DD}$	Supply voltage	-	1.62	2.6	3.6	V
$t_{SU(BOOST)}$	Booster startup time	-	-	-	50	$\mu s$
$I_{DD(BOOST)}$	Booster consumption	$1.62 V \leq V_{DD} \leq 2.7 V$	-	-	125	$\mu A$
		$2.7 V < V_{DD} < 3.6 V$	-	-	250	

1. Guaranteed by characterization results.

## 7.3.26 Comparator characteristics

Table 194. COMP characteristics<sup>(1)</sup>

Symbol	Parameter	Conditions	Min	Typ	Max	Unit	
$V_{DDA}$	Analog supply voltage	-	1.62	3.3	3.6	V	
$V_{IN}$	Comparator input voltage range	-	0	-	$V_{DDA}$		
$V_{BG}$	Scaler input voltage	-	(2)				
$V_{SC}$	Scaler offset voltage	-	-	±5	±10	mV	
$I_{DDA(SCALER)}$	Scaler static consumption from $V_{DDA}$	BRG_EN=0 (bridge disable)	-	0.2	0.3	µA	
		BRG_EN=1 (bridge enable)	-	0.8	1		
$t_{START\_SCALER}$	Scaler startup time	-	-	140	250	µs	
$t_{START}$	Comparator startup time to reach propagation delay specification	High-speed mode	-	2	5	µs	
		Medium mode	-	5	20		
		Ultra-low-power mode	-	15	80		
$t_D^{(3)}$	Propagation delay for 200 mV step with 100 mV overdrive	High-speed mode	-	50	80	ns	
		Medium mode	-	0.5	1.2		µs
		Ultra-low-power mode	-	2.5	7		
	Propagation delay for step > 200 mV with 100 mV overdrive only on positive inputs	High-speed mode	-	50	120	ns	
		Medium mode	-	0.5	1.2		µs
		Ultra-low-power mode	-	2.5	7		
$V_{offset}$	Comparator offset error	Full common mode range	-	±5	±20	mV	
$V_{hys}$	Comparator hysteresis	No hysteresis	-	0	-	mV	
		Low hysteresis	5	10	22		
		Medium hysteresis	8	20	37		
		High hysteresis	16	30	52		
$I_{DDA(COMP)}$	Comparator consumption from $V_{DDA}$	Ultra-low-power mode	Static	-	400	600	nA
			With 50 kHz ±100 mV overdrive square signal	-	800	-	
		Medium mode	Static	-	5	7	µA
			With 50 kHz ±100 mV overdrive square signal	-	6	-	
		High-speed mode	Static	-	70	100	
			With 50 kHz ±100 mV overdrive square signal	-	75	-	

1. Guaranteed by design, unless otherwise specified.
2. Refer to [Table 125: Embedded reference voltage](#).

3. Guaranteed by characterization results.

### 7.3.27 Operational amplifier characteristics

Table 195. Operational amplifier characteristics

Symbol	Parameter	Conditions	Min	Typ	Max	Unit
$V_{DDA}$	Analog supply voltage Range	-	2	3.3	3.6	V
CMIR	Common Mode Input Range	-	0	-	$V_{DDA}$	
$V_{I\text{OFFSET}}$	Input offset voltage	25°C, no load on output	-	-	±1.5	mV
		All voltages and temperature, no load	-	-	±2.5	
$\Delta V_{I\text{OFFSET}}$	Input offset voltage drift	-	-	±3.0	-	µV/°C
TRIMOFFSETP TRIMLPOFFSETP	Offset trim step at low common input voltage (0.1* $V_{DDA}$ )	-	-	1.1	1.5	mV
TRIMOFFSETN TRIMLPOFFSETN	Offset trim step at high common input voltage (0.9* $V_{DDA}$ )	-	-	1.1	1.5	
$I_{LOAD}$	Drive current	-	-	-	500	µA
$I_{LOAD\_PGA}$	Drive current in PGA mode	-	-	-	270	
$C_{LOAD}$	Capacitive load	-	-	-	50	pF
CMRR	Common mode rejection ratio	-	-	80	-	dB
PSRR	Power supply rejection ratio	$C_{LOAD} \leq 50\text{pf} /$ $R_{LOAD} \geq 4\text{ k}\Omega^{(1)}$ at 1 kHz, $V_{com} = V_{DDA}/2$	50	66	-	dB
GBW	Gain bandwidth for high supply range	200 mV ≤ Output dynamic range ≤ $V_{DDA} - 200\text{ mV}$	4	7.3	12.3	MHz
SR	Slew rate (from 10% and 90% of output voltage)	Normal mode	-	3	-	V/µs
		High-speed mode	-	30	-	
AO	Open loop gain	200 mV ≤ Output dynamic range ≤ $V_{DDA} - 200\text{ mV}$	59	90	129	dB
$\phi_m$	Phase margin	-	-	55	-	°
GM	Gain margin	-	-	12	-	dB
$V_{OHSAT}$	High saturation voltage	$I_{load} = \text{max}$ or $R_{LOAD} = \text{min}$ , Input at $V_{DDA}$	$V_{DDA} - 100\text{ mV}$	-	-	mV
$V_{OLSAT}$	Low saturation voltage	$I_{load} = \text{max}$ or $R_{LOAD} = \text{min}$ , Input at 0 V	-	-	100	

Table 195. Operational amplifier characteristics (continued)

Symbol	Parameter	Conditions		Min	Typ	Max	Unit
$t_{WAKEUP}$	Wake up time from OFF state	Normal mode	$C_{LOAD} \leq 50\text{pf}$ , $R_{LOAD} \geq 4\text{ k}\Omega$ , follower configuration	-	0.8	3.2	$\mu\text{s}$
		High speed mode	$C_{LOAD} \leq 50\text{pf}$ , $R_{LOAD} \geq 4\text{ k}\Omega$ , follower configuration	-	0.9	2.8	
PGA gain	Non inverting gain error value	PGA gain = 2		-1	-	1	%
		PGA gain = 4		-2	-	2	
		PGA gain = 8		-2.5	-	2.5	
		PGA gain = 16		-3	-	3	
	Inverting gain error value	PGA gain = 2		-1	-	1	
		PGA gain = 4		-1	-	1	
		PGA gain = 8		-2	-	2	
		PGA gain = 16		-3	-	3	
	External non-inverting gain error value	PGA gain = 2		-1	-	1	
		PGA gain = 4		-3	-	3	
		PGA gain = 8		-3.5	-	3.5	
		PGA gain = 16		-4	-	4	
$R_{network}$	R2/R1 internal resistance values in non-inverting PGA mode <sup>(2)</sup>	PGA Gain=2		-	10/10	-	k $\Omega$ / k $\Omega$
		PGA Gain=4		-	30/10	-	
		PGA Gain=8		-	70/10	-	
		PGA Gain=16		-	150/10	-	
	R2/R1 internal resistance values in inverting PGA mode <sup>(2)</sup>	PGA Gain = -1		-	10/10	-	
		PGA Gain = -3		-	30/10	-	
		PGA Gain = -7		-	70/10	-	
		PGA Gain = -15		-	150/10	-	
Delta R	Resistance variation (R1 or R2)	-		-15	-	15	%

**Table 195. Operational amplifier characteristics (continued)**

Symbol	Parameter	Conditions	Min	Typ	Max	Unit	
PGA BW	PGA bandwidth for different non inverting gain	Gain=2	-	GBW/2	-	MHz	
		Gain=4	-	GBW/4	-		
		Gain=8	-	GBW/8	-		
		Gain=16	-	GBW/16	-		
	PGA bandwidth for different inverting gain	Gain = -1	-	5.00	-	MHz	
		Gain = -3	-	3.00	-		
		Gain = -7	-	1.50	-		
		Gain = -15	-	0.80	-		
en	Voltage noise density	at 1 KHz	output loaded with 4 kΩ	-	140	-	nV/ $\sqrt{\text{Hz}}$
		at 10 KHz		-	55	-	
I <sub>DDA(OPAMP)</sub>	OPAMP consumption from V <sub>DDA</sub>	Normal mode	no Load, quiescent mode, follower	-	570	1000	μA
		High-speed mode		-	610	1200	

- R<sub>LOAD</sub> is the resistive load connected to VSSA or to VDDA.
- R2 is the internal resistance between the OPAMP output and th OPAMP inverting input. R1 is the internal resistance between the OPAMP inverting input and ground. PGA gain = 1 + R2/R1.

### 7.3.28 Digital filter for Sigma-Delta Modulators (DFSDM) characteristics

Unless otherwise specified, the parameters given in [Table 196](#) for DFSDM are derived from tests performed under the ambient temperature, fPCLKx frequency and supply voltage conditions summarized in [Table 120: General operating conditions](#).

- Output speed is set to OSPEEDRy[1:0] = 10
- Capacitive load C<sub>L</sub> = 30 pF
- Measurement points are done at CMOS levels: 0.5V<sub>DD</sub>
- VOS level set to VOS1

Refer to [Section 7.3.15: I/O port characteristics](#) for more details on the input/output alternate function characteristics (DiFSDM\_CKINx, DFSDM\_DATINx, DFSDM\_CKOUT for DFSDM).

Table 196. DFSDM measured timing - 1.62-3.6 V

Symbol	Parameter	Conditions	Min	Typ	Max	Unit
$f_{DFSDMCLK}$	DFSDM clock	$1.62 < V_{DD} < 3.6 V$	-	-	250	MHz
$f_{CKIN}$ ( $1/T_{CKIN}$ )	Input clock frequency	SPI mode (SITP[1:0]=0,1), External clock mode (SPICKSEL[1:0]=0), $1.62 < V_{DD} < 3.6 V$	-	-	20	
		SPI mode (SITP[1:0]=0,1), External clock mode (SPICKSEL[1:0]=0), $2.7 < V_{DD} < 3.6 V$	-	-	20	
		SPI mode (SITP[1:0]=0,1), Internal clock mode (SPICKSEL[1:0]'0), $1.62 < V_{DD} < 3.6 V$	-	-	20	
		SPI mode (SITP[1:0]=0,1), Internal clock mode (SPICKSEL[1:0]'0), $2.7 < V_{DD} < 3.6 V$	-	-	20	
$f_{CKOUT}$	Output clock frequency	$1.62 < V_{DD} < 3.6 V$	-	-	20	
$DuCY_{CKOUT}$ T	Output clock frequency duty cycle	$1.62 < V_{DD} < 3.6 V$	45	50	55	%
$t_{wh(CKIN)}$ $t_{wl(CKIN)}$	Input clock high and low time	SPI mode (SITP[1:0]=0,1), External clock mode (SPICKSEL[1:0]=0), $1.62 < V_{DD} < 3.6 V$	$T_{CKIN}/2-0.5$	$T_{CKIN}/2$	-	ns
$t_{su}$	Data input setup time	SPI mode (SITP[1:0]=0,1), External clock mode (SPICKSEL[1:0]=0), $1.62 < V_{DD} < 3.6 V$	1.5	-	-	
$t_h$	Data input hold time	SPI mode (SITP[1:0]=0,1), External clock mode (SPICKSEL[1:0]=0), $1.62 < V_{DD} < 3.6 V$	0.5	-	-	
$T_{Manchester}$	Manchester data period (recovered clock period)	Manchester mode (SITP[1:0]=2,3), Internal clock mode (SPICKSEL[1:0]'0), $1.62 < V_{DD} < 3.6 V$	$(CKOUTDIV+1) * T_{DFSDMCLK}$	-	$(2*CKOUTDIV) * T_{DFSDMCLK}$	

Figure 93. Channel transceiver timing diagrams

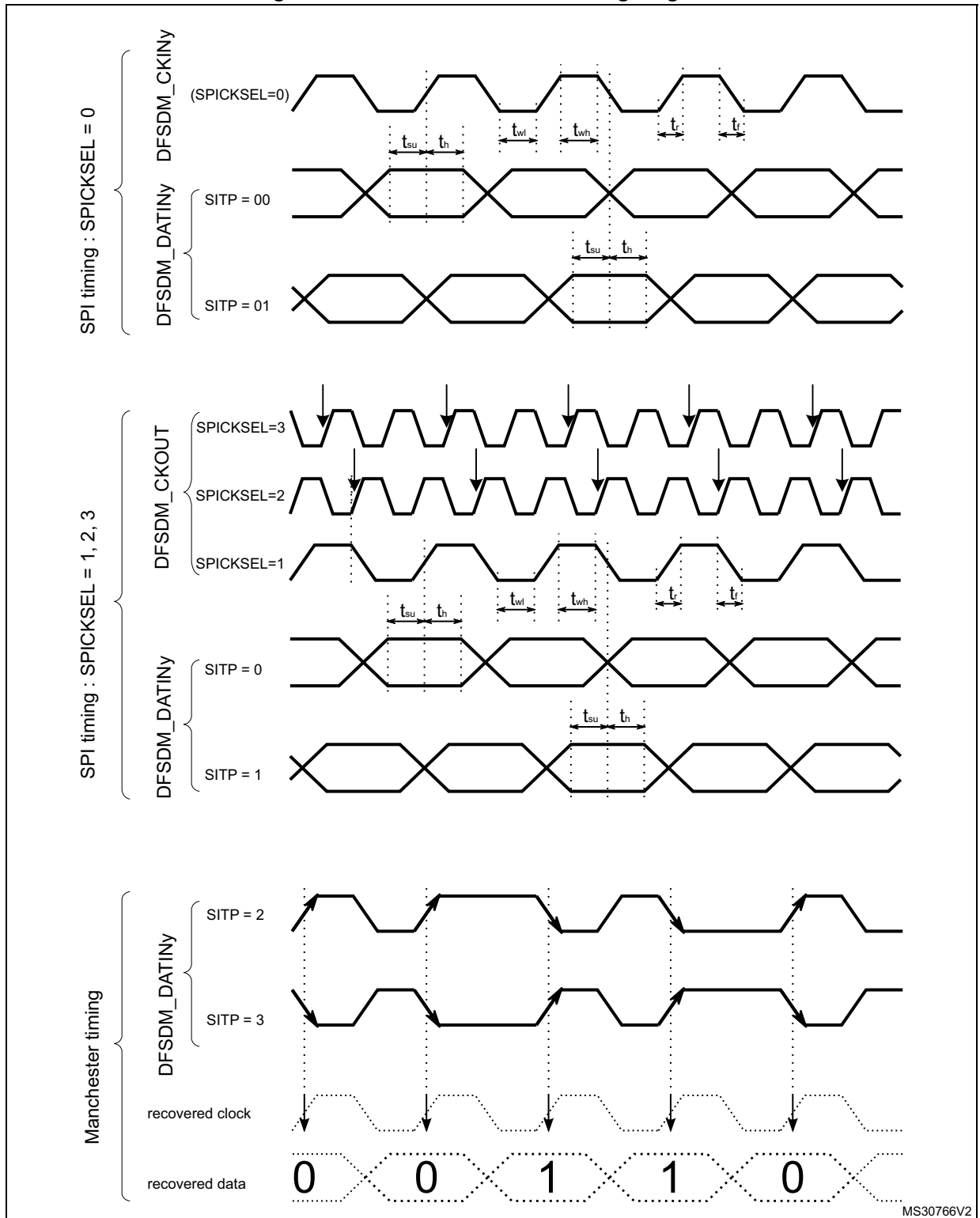



### 7.3.29 Camera interface (DCMI) timing specifications

Unless otherwise specified, the parameters given in [Table 197](#) for DCMI are derived from tests performed under the ambient temperature,  $f_{HCLK}$  frequency and VDD supply voltage summarized in [Table 120: General operating conditions](#), with the following configuration:

- DCMI\_PIXCLK polarity: falling
- DCMI\_VSYNC and DCMI\_HSYNC polarity: high
- Data formats: 14 bits
- Capacitive load  $C_L=30$  pF
- Measurement points are done at CMOS levels:  $0.5V_{DD}$
- VOS level set to VOS1

**Table 197. DCMI characteristics<sup>(1)</sup>**

Symbol	Parameter	Min	Max	Unit
-	Frequency ratio DCMI_PIXCLK/ $f_{HCLK}$	-	0.4	-
DCMI_PIXCLK	Pixel Clock input	-	80	MHz
$D_{pixel}$	Pixel Clock input duty cycle	30	70	%
$t_{su}(DATA)$	Data input setup time	3	-	-
$t_h(DATA)$	Data hold time	1	-	-
$t_{su}(HSYNC)$ , $t_{su}(VSYNC)$	DCMI_HSYNC/ DCMI_VSYNC input setup time	2	-	ns
$t_h(HSYNC)$ , $t_h(VSYNC)$	DCMI_HSYNC/ DCMI_VSYNC input hold time	1	-	-

1. Guaranteed by characterization results.

**Figure 94. DCMI timing diagram**

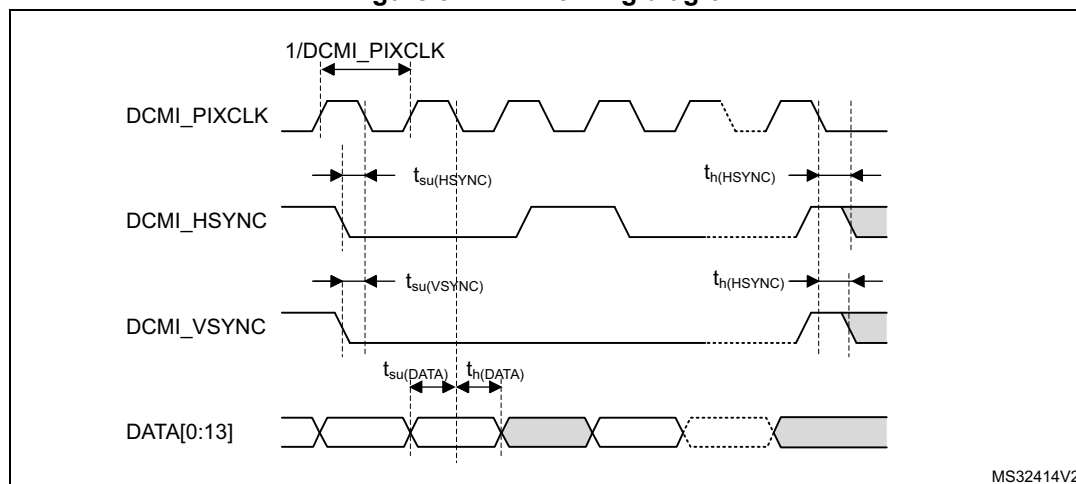

### 7.3.30 LCD-TFT controller (LTDC) characteristics

Unless otherwise specified, the parameters given in [Table 198](#) for LCD-TFT are derived from tests performed under the ambient temperature,  $f_{HCLK}$  frequency and VDD supply voltage summarized in [Table 120: General operating conditions](#), with the following configuration:

- LCD\_CLK polarity: high
- LCD\_DE polarity: low
- LCD\_VSYNC and LCD\_HSYNC polarity: high
- Pixel formats: 24 bits
- Output speed is set to OSPEEDRy[1:0] = 11
- Capacitive load  $C_L=30$  pF
- Measurement points are done at CMOS levels: 0.5VDD
- IO Compensation cell activated.
- HSLV activated when  $V_{DD} \leq 2.7$  V
- VOS level set to VOS1

**Table 198. LTDC characteristics<sup>(1)</sup>**

Symbol	Parameter		Min	Max	Unit
$f_{CLK}$	LTDC clock output frequency	$2.7 < V_{DD} < 3.6$ V 20pF	-	150	MHz
		$2.7 < V_{DD} < 3.6$ V		133	
		$1.62 < V_{DD} < 3.6$ V		90	
$D_{CLK}$	LTDC clock output duty cycle		45	55	%
$t_{w(CLKH)}$ , $t_{w(CLKL)}$	Clock High time, low time		$t_{w(CLK)}/2-0.5$	$t_{w(CLK)}/2+0.5$	-
$t_{v(DATA)}$	Data output valid time	$2.7 < V_{DD} < 3.6$ V	-	0.5	-
$t_{h(DATA)}$		$1.62 < V_{DD} < 3.6$ V		5	
$t_{v(DATA)}$	Data output hold time		0	-	-
$t_{v(HSYNC)}$ , $t_{v(VSYNC)}$ , $t_{v(DE)}$	HSYNC/VSYNC/DE output valid time	$2.7 < V_{DD} < 3.6$ V	-	0.5	-
		$1.62 < V_{DD} < 3.6$ V	-	5	-
$t_{h(HSYNC)}$ , $t_{h(VSYNC)}$ , $t_{h(DE)}$	HSYNC/VSYNC/DE output hold time		0	-	-

1. Guaranteed by characterization results.

Figure 95. LCD-TFT horizontal timing diagram

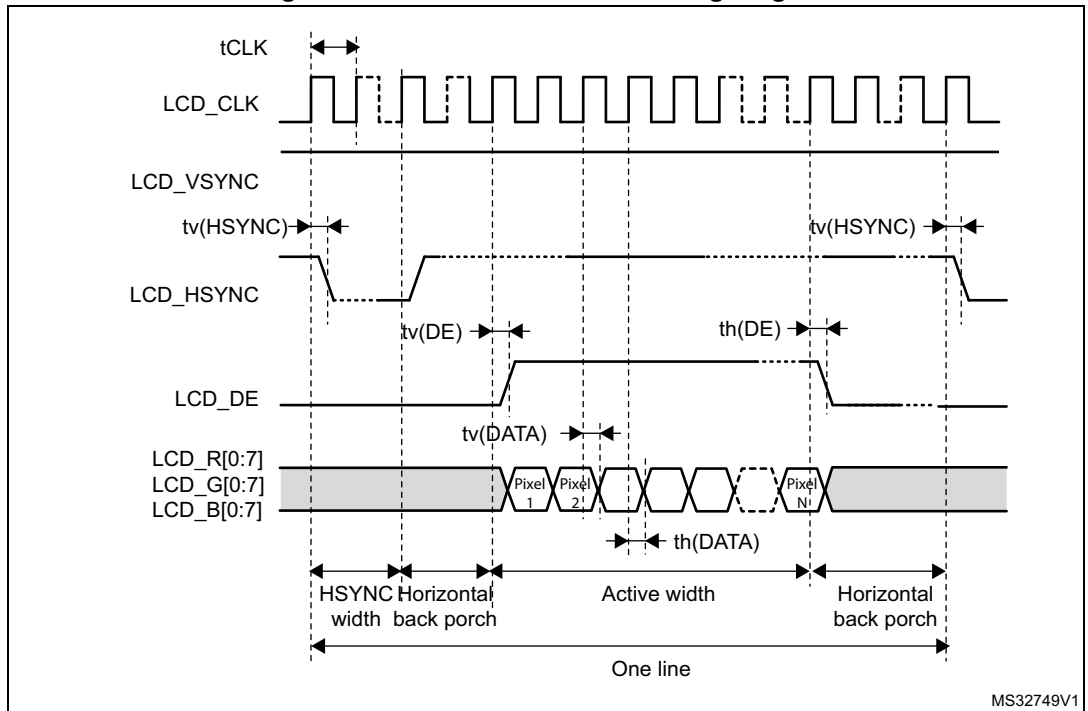
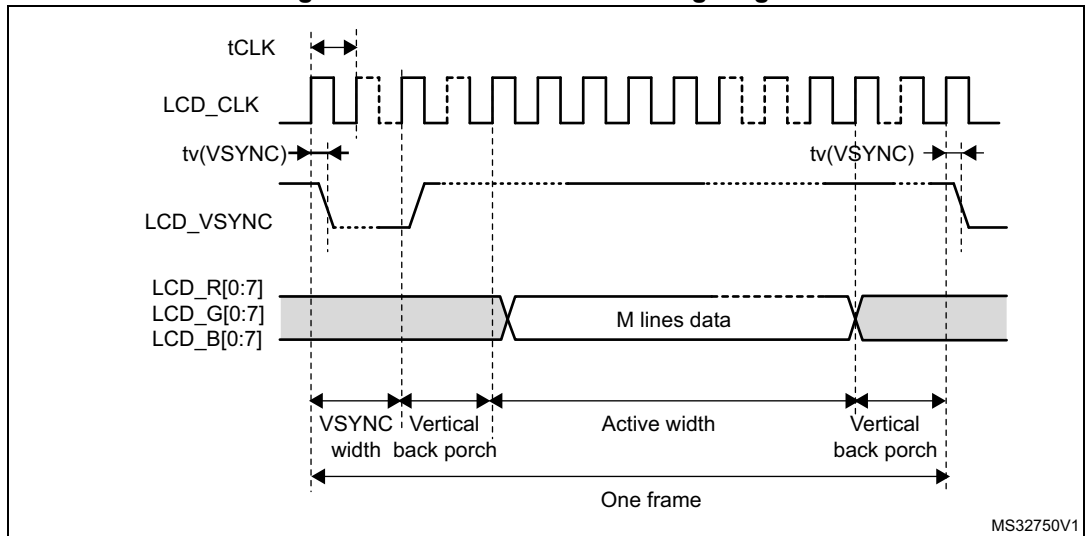

Figure 96. LCD-TFT vertical timing diagram



### 7.3.31 Timer characteristics

The parameters given in [Table 199](#) are guaranteed by design.

Refer to [Section 7.3.15: I/O port characteristics](#) for details on the input/output alternate function characteristics (output compare, input capture, external clock, PWM output).

**Table 199. TIMx characteristics<sup>(1)(2)</sup>**

Symbol	Parameter	Conditions <sup>(3)</sup>	Min	Max	Unit
$t_{res(TIM)}$	Timer resolution time	AHB/APBx prescaler=1 or 2 or 4, $f_{TIMxCLK} = 240$ MHz	1	-	$t_{TIMxCLK}$
		AHB/APBx prescaler>4, $f_{TIMxCLK} = 120$ MHz	1	-	$t_{TIMxCLK}$
$f_{EXT}$	Timer external clock frequency on CH1 to CH4	$f_{TIMxCLK} = 240$ MHz	0	$f_{TIMxCLK}/2$	MHz
$Res_{TIM}$	Timer resolution		-	16/32	bit
$t_{MAX\_COUNT}$	Maximum possible count with 32-bit counter	-	-	$65536 \times 65536$	$t_{TIMxCLK}$

- TIMx is used as a general term to refer to the TIM1 to TIM17 timers.
- Guaranteed by design.
- The maximum timer frequency on APB1 or APB2 is up to 240 MHz, by setting the TIMPRE bit in the RCC\_CFGR register, if APBx prescaler is 1 or 2 or 4, then  $TIMxCLK = rcc_hclk1$ , otherwise  $TIMxCLK = 4 \times F_{rcc\_pclkx\_d2}$ .

### 7.3.32 Communication interfaces

#### I<sup>2</sup>C interface characteristics

The I<sup>2</sup>C interface meets the timings requirements of the I<sup>2</sup>C-bus specification and user manual revision 03 for:

- Standard-mode (Sm): with a bit rate up to 100 kbit/s
- Fast-mode (Fm): with a bit rate up to 400 kbit/s
- Fast-mode Plus (Fm+): with a bit rate up to 1 Mbit/s.

The I<sup>2</sup>C timings requirements are guaranteed by design when the I<sup>2</sup>C peripheral is properly configured (refer to RM0399 reference manual) and when the `i2c_ker_ck` frequency is greater than the minimum shown in the table below:

**Table 200. Minimum i2c\_ker\_ck frequency in all I<sup>2</sup>C modes**

Symbol	Parameter	Condition		Min	Unit
f(I2CCLK)	I2CCLK frequency	Standard-mode	-	2	MHz
		Fast-mode	Analog Filtre ON DNF=0	8	
			Analog Filtre OFF DNF=1	9	
		Fast-mode Plus	Analog Filtre ON DNF=0	17	
			Analog Filtre OFF DNF=1	16	-

The SDA and SCL I/O requirements are met with the following restrictions:

- The SDA and SCL I/O pins are not “true” open-drain. When configured as open-drain, the PMOS connected between the I/O pin and V<sub>DDIOx</sub> is disabled, but still present.
- The 20 mA output drive requirement in Fast-mode Plus is not supported. This limits the maximum load C<sub>Load</sub> supported in Fm+, which is given by these formulas:

$$t_{r(SDA/SCL)} = 0.8473 \times R_P \times C_{Load}$$

$$R_{P(min)} = (V_{DD} - V_{OL(max)}) / I_{OL(max)}$$

Where R<sub>P</sub> is the I<sup>2</sup>C lines pull-up. Refer to [Section 7.3.15: I/O port characteristics](#) for the I<sup>2</sup>C I/Os characteristics.

All I<sup>2</sup>C SDA and SCL I/Os embed an analog filter. Refer to the table below for the analog filter characteristics:

**Table 201. I<sup>2</sup>C analog filter characteristics<sup>(1)</sup>**

Symbol	Parameter	Min	Max	Unit
t <sub>AF</sub>	Maximum pulse width of spikes that are suppressed by analog filter	50 <sup>(2)</sup>	80 <sup>(3)</sup>	ns

- Guaranteed by characterization results.
- Spikes with widths below t<sub>AF(min)</sub> are filtered.
- Spikes with widths above t<sub>AF(max)</sub> are not filtered.

## USART interface characteristics

Unless otherwise specified, the parameters given in [Table 202](#) for USART are derived from tests performed under the ambient temperature, f<sub>PCLKx</sub> frequency and V<sub>DD</sub> supply voltage conditions summarized in [Table 120: General operating conditions](#), with the following configuration:

- Output speed is set to OSPEEDRy[1:0] = 10
- Capacitive load C<sub>L</sub> = 30 pF
- Measurement points are done at CMOS levels: 0.5V<sub>DD</sub>
- IO Compensation cell activated.
- VOS level set to VOS1

Refer to [Section 7.3.15: I/O port characteristics](#) for more details on the input/output alternate function characteristics (NSS, CK, TX, RX for USART).

**Table 202. USART characteristics<sup>(1)</sup>**

Symbol	Parameter	Conditions	Min	Typ	Max	Unit
f <sub>CK</sub>	USART clock frequency	Master mode	-	-	12.5	MHz
		Slave mode			25	
t <sub>su(NSS)</sub>	NSS setup time	Slave mode	t <sub>ker</sub> +1	-	-	-
t <sub>h(NSS)</sub>	NSS hold time	Slave mode	2	-	-	
t <sub>w(SCKH)</sub> , t <sub>w(SCKL)</sub>	CK high and low time	Master mode	1/f <sub>CK</sub> /2-2	1/f <sub>CK</sub> /2	1/f <sub>CK</sub> /2+2	
t <sub>su(RX)</sub>	Data input setup time	Master mode	t <sub>ker</sub> +6	-	-	ns
		Slave mode	1.5	-	-	
t <sub>h(RX)</sub>	Data input hold time	Master mode	0	-	-	
		Slave mode	1.5	-	-	
t <sub>v(TX)</sub>	Data output valid time	Slave mode	-	12	20	
		Master mode	-	0.5	1	
t <sub>h(TX)</sub>	Data output hold time	Slave mode	9	-	-	
		Master mode	0	-	-	

1. Guaranteed by characterization results.

Figure 97. USART timing diagram in Master mode

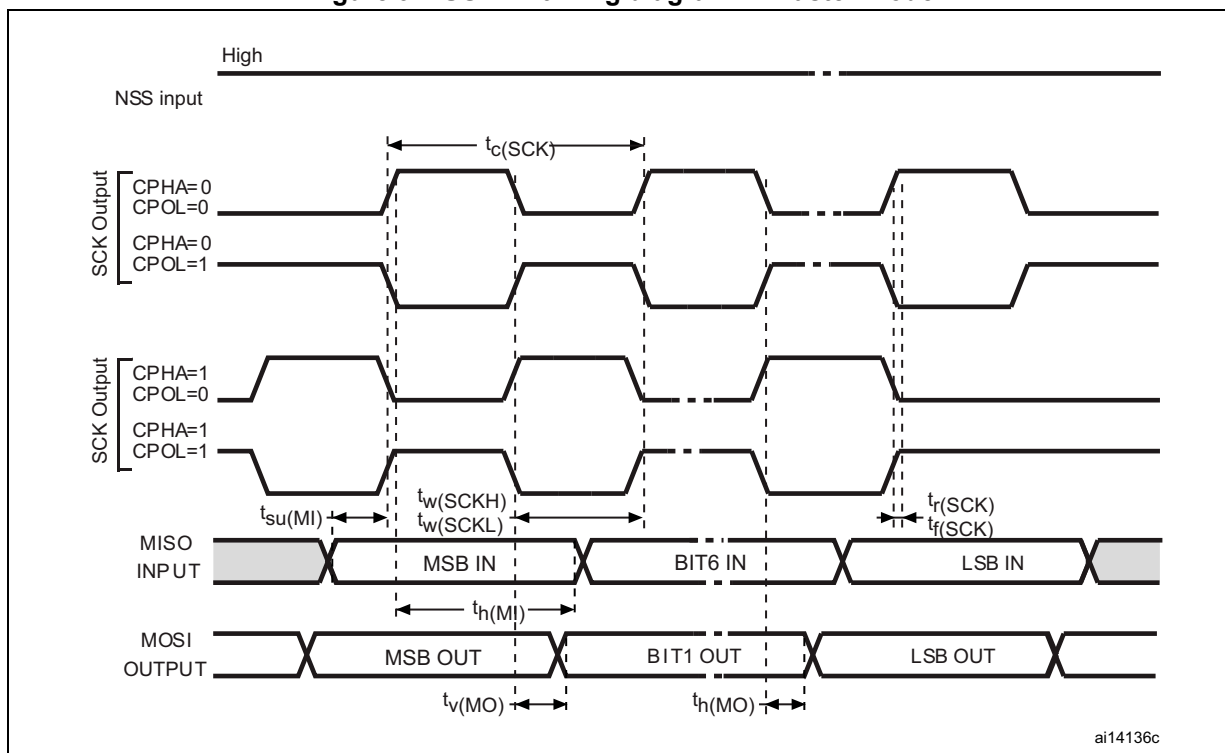

1. Measurement points are done at  $0.5V_{DD}$  and with external  $C_L = 30$  pF.

Figure 98. USART timing diagram in Slave mode

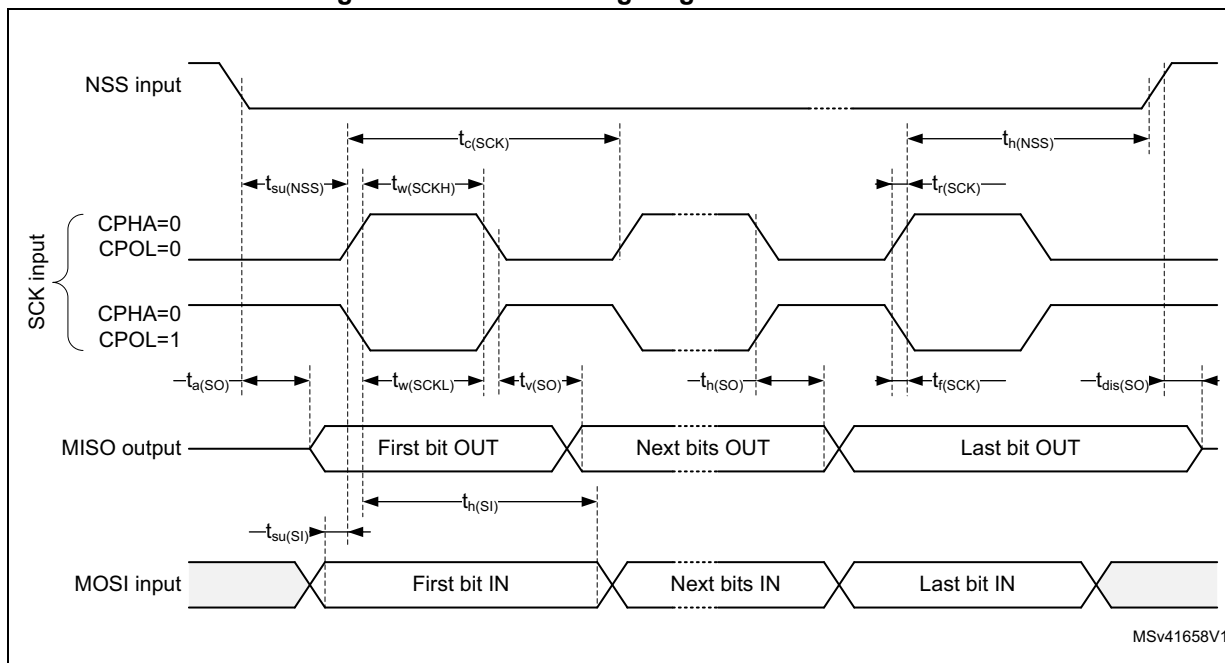

### SPI interface characteristics

Unless otherwise specified, the parameters given in [Table 203](#) for SPI are derived from tests performed under the ambient temperature,  $f_{PCLKx}$  frequency and  $V_{DD}$  supply voltage conditions summarized in [Table 120: General operating conditions](#), with the following configuration:

- Output speed is set to  $OSPEEDRy[1:0] = 11$
- Capacitive load  $C_L = 30$  pF
- Measurement points are done at CMOS levels:  $0.5V_{DD}$
- IO Compensation cell activated.
- HSLV activated when  $V_{DD} \leq 2.7$  V
- VOS level set to VOS1

Refer to [Section 7.3.15: I/O port characteristics](#) for more details on the input/output alternate function characteristics (NSS, SCK, MOSI, MISO for SPI).

**Table 203. SPI characteristics<sup>(1)</sup>**

Symbol	Parameter	Conditions	Min	Typ	Max	Unit
$f_{SCK}$	SPI clock frequency	Master mode $1.62 < V_{DD} < 3.6$ V SPI1, 2, 3	-	-	80	MHz
		Master mode $2.7 < V_{DD} < 3.6$ V SPI1, 2, 3			100	
		Master mode $1.62 < V_{DD} < 3.6$ V SPI4, 5, 6			50	
		Slave receiver mode $1.62 < V_{DD} < 3.6$ V			100	
		Slave mode transmitter/full duplex $2.7 < V_{DD} < 3.6$ V			31	
		Slave mode transmitter/full duplex $1.62 < V_{DD} < 3.6$ V			29	
$t_{su(NSS)}$	NSS setup time	Slave mode	2	-	-	-
$t_{h(NSS)}$	NSS hold time	Slave mode	1	-	-	
$t_w(SCKH)$ , $t_w(SCKL)$	SCK high and low time	Master mode	$T_{PCLK}-2$	$T_{PCLK}$	$T_{PCLK}+2$	



Table 203. SPI characteristics<sup>(1)</sup> (continued)

Symbol	Parameter	Conditions	Min	Typ	Max	Unit
$t_{su(MI)}$	Data input setup time	Master mode	1	-	-	ns
$t_{su(SI)}$		Slave mode	1	-	-	
$t_{h(MI)}$	Data input hold time	Master mode	4	-	-	
$t_{h(SI)}$		Slave mode	2	-	-	
$t_{a(SO)}$	Data output access time	Slave mode	9	13	27	
$t_{dis(SO)}$	Data output disable time	Slave mode	0	1	5	
$t_{v(SO)}$	Data output valid time	Slave mode 2.7 < $V_{DD}$ < 3.6 V	-	12.5	16	
		Slave mode 1.62 < $V_{DD}$ < 3.6 V	-	12.5	17	
$t_{v(MO)}$		Master mode	-	1	3	
$t_{h(SO)}$	Data output hold time	Slave mode 1.62 < $V_{DD}$ < 3.6 V	10	-	-	
$t_{h(MO)}$		Master mode	0	-	-	

1. Guaranteed by characterization results.

Figure 99. SPI timing diagram - slave mode and CPHA = 0

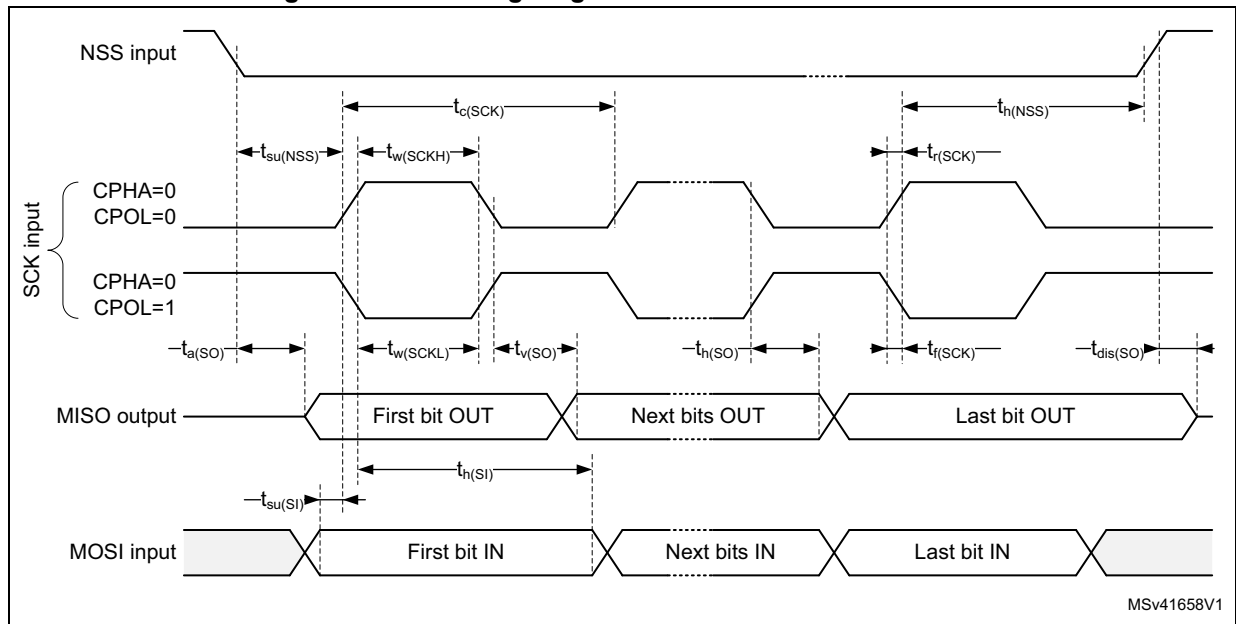
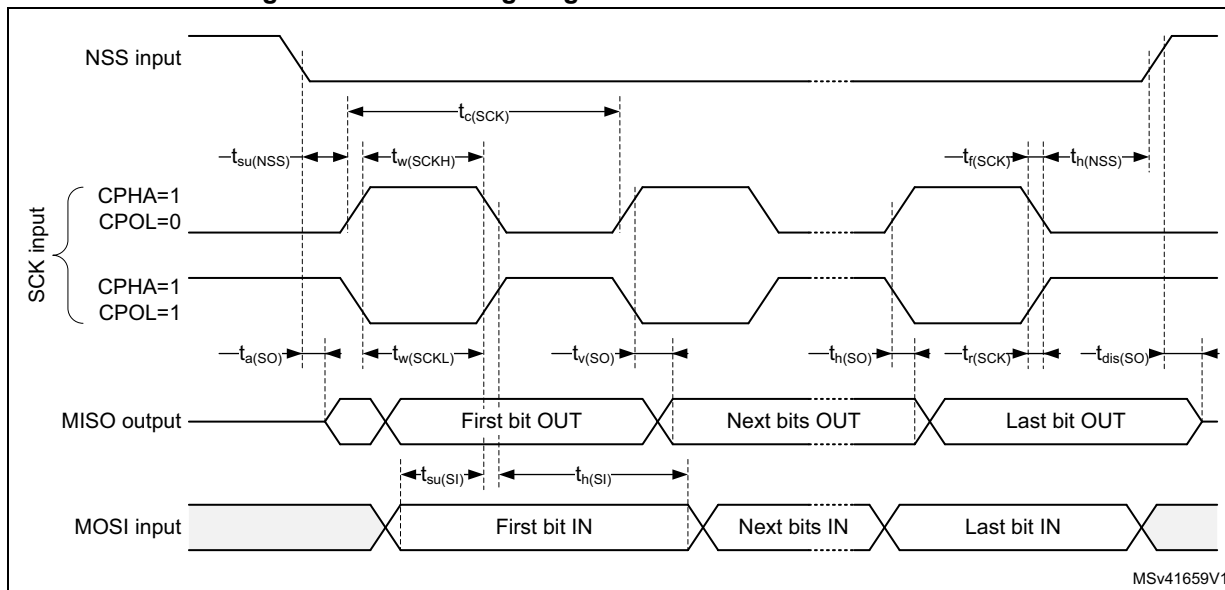
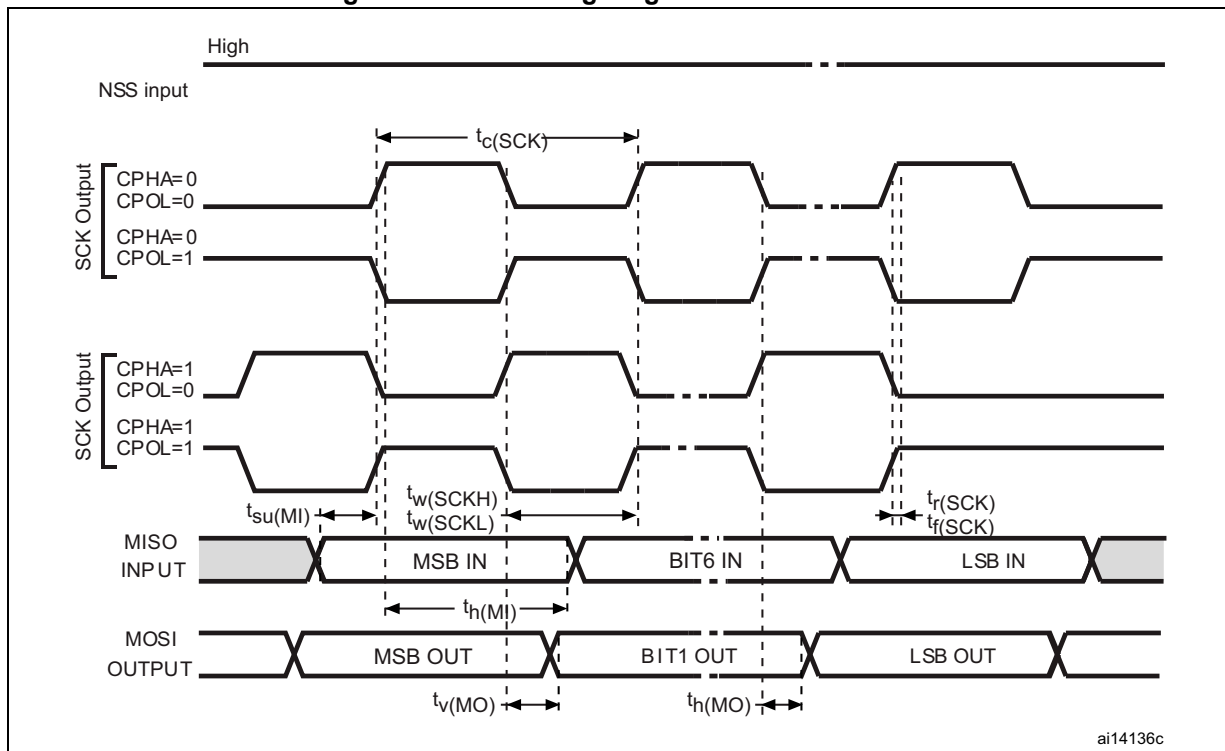

Figure 100. SPI timing diagram - slave mode and CPHA = 1<sup>(1)</sup>



1. Measurement points are done at 0.5V<sub>DD</sub> and with external C<sub>L</sub> = 30 pF.

Figure 101. SPI timing diagram - master mode<sup>(1)</sup>



1. Measurement points are done at 0.5V<sub>DD</sub> and with external C<sub>L</sub> = 30 pF.

## I<sup>2</sup>S Interface characteristics

Unless otherwise specified, the parameters given in [Table 204](#) for I<sup>2</sup>S are derived from tests performed under the ambient temperature,  $f_{PCLKx}$  frequency and  $V_{DD}$  supply voltage conditions summarized in [Table 120: General operating conditions](#), with the following configuration:

- Output speed is set to  $OSPEEDRy[1:0] = 10$
- Capacitive load  $C_L = 30$  pF
- Measurement points are done at CMOS levels:  $0.5V_{DD}$
- IO Compensation cell activated.
- HSLV activated when  $V_{DD} \leq 2.7$  V
- VOS level set to VOS1

Refer to [Section 7.3.15: I/O port characteristics](#) for more details on the input/output alternate function characteristics (CK,SD,WS).

**Table 204. I<sup>2</sup>S dynamic characteristics<sup>(1)</sup>**

Symbol	Parameter	Conditions	Min	Max	Unit
$f_{MCK}$	I <sup>2</sup> S main clock output	-	256x8K	$256F_S$	MHz
$f_{CK}$	I <sup>2</sup> S clock frequency	Master data	-	$64F_S$	MHz
		Slave data	-	$64F_S$	
$t_{v(WS)}$	WS valid time	Master mode	-	3	ns
$t_{h(WS)}$	WS hold time	Master mode	0	-	
$t_{su(WS)}$	WS setup time	Slave mode	1	-	
$t_{h(WS)}$	WS hold time	Slave mode	1	-	
$t_{su(SD\_MR)}$	Data input setup time	Master receiver	1	-	
$t_{su(SD\_SR)}$		Slave receiver	1	-	
$t_{h(SD\_MR)}$	Data input hold time	Master receiver	4	-	
$t_{h(SD\_SR)}$		Slave receiver	2	-	
$t_{v(SD\_ST)}$	Data output valid time	Slave transmitter (after enable edge)	-	17	
$t_{v(SD\_MT)}$		Master transmitter (after enable edge)	-	3	
$t_{h(SD\_ST)}$	Data output hold time	Slave transmitter (after enable edge)	9	-	
$t_{h(SD\_MT)}$		Master transmitter (after enable edge)	0	-	

1. Guaranteed by characterization results.

Figure 102. I<sup>2</sup>S slave timing diagram (Philips protocol)<sup>(1)</sup>

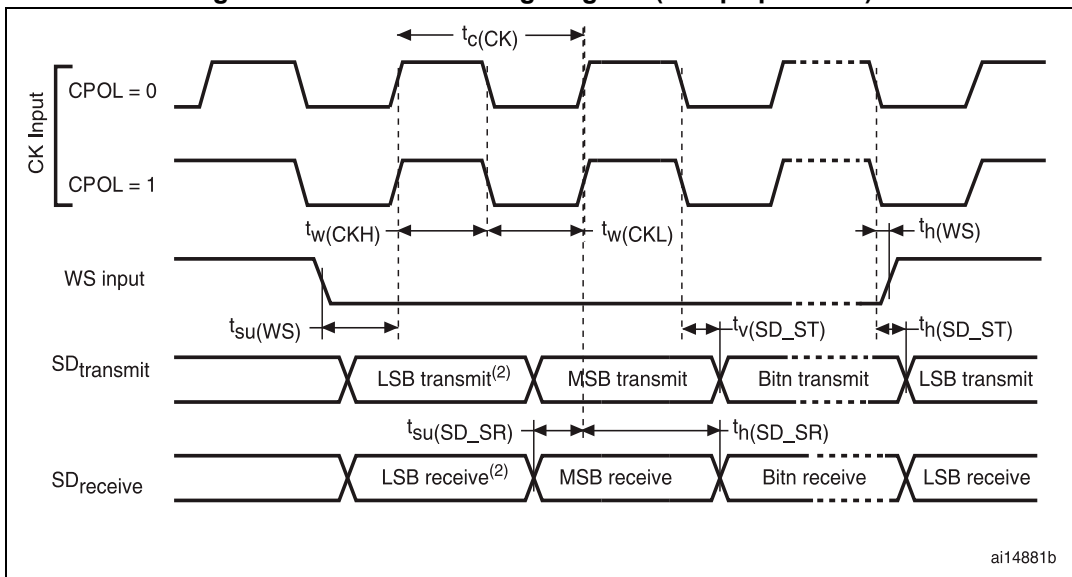

1. LSB transmit/receive of the previously transmitted byte. No LSB transmit/receive is sent before the first byte.

Figure 103. I<sup>2</sup>S master timing diagram (Philips protocol)<sup>(1)</sup>

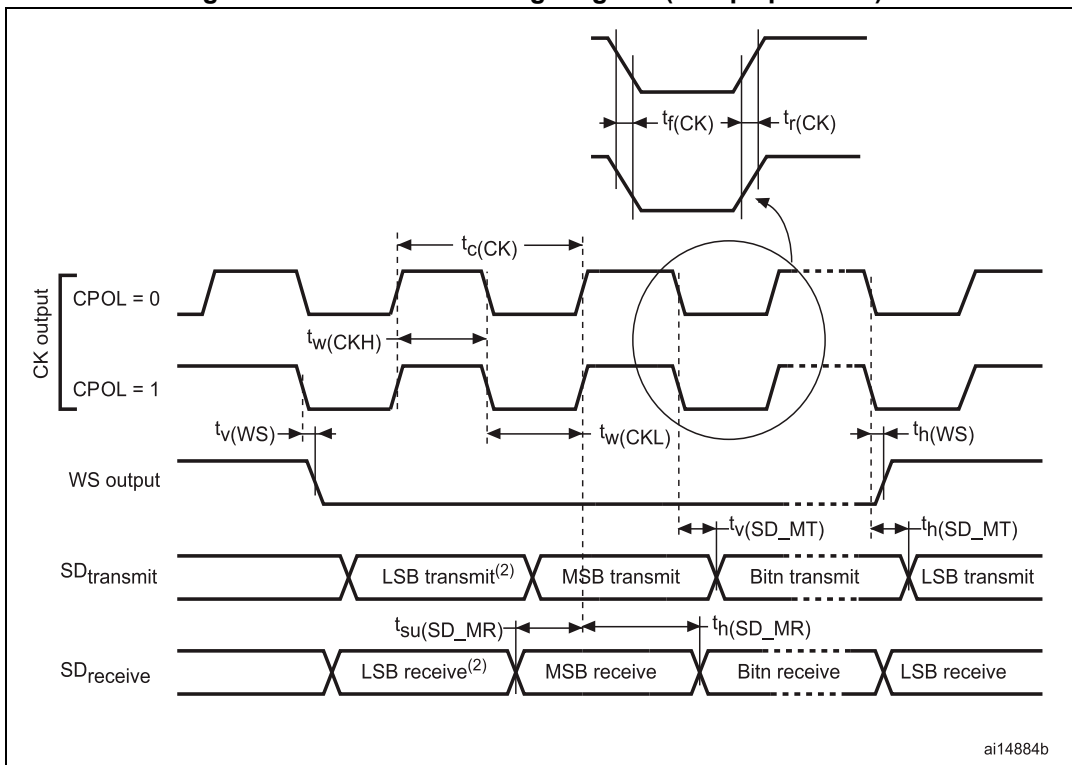

1. LSB transmit/receive of the previously transmitted byte. No LSB transmit/receive is sent before the first byte.

**SAI characteristics**

Unless otherwise specified, the parameters given in [Table 205](#) for SAI are derived from tests performed under the ambient temperature,  $f_{PCLKx}$  frequency and VDD supply voltage conditions summarized in [Table 120: General operating conditions](#), with the following configuration:

- Output speed is set to OSPEEDRy[1:0] = 10
- Capacitive load  $C_L = 30$  pF
- IO Compensation cell activated.
- Measurement points are done at CMOS levels: 0.5VDD
- VOS level set to VOS1.

Refer to [Section 7.3.15: I/O port characteristics](#) for more details on the input/output alternate function characteristics (SCK,SD,WS).

**Table 205. SAI characteristics<sup>(1)</sup>**

Symbol	Parameter	Conditions	Min	Max	Unit
$f_{MCK}$	SAI Main clock output	-	256x8K	256x $F_S$	MHz
$f_{CK}$	SAI clock frequency <sup>(2)</sup>	Master Data: 32 bits	-	128x $F_S$ <sup>(3)</sup>	
		Slave Data: 32 bits	-	128x $F_S$ <sup>(3)</sup>	

Table 205. SAI characteristics<sup>(1)</sup> (continued)

Symbol	Parameter	Conditions	Min	Max	Unit
$t_{V(FS)}$	$F_S$ valid time	Master mode $2.7 \leq V_{DD} \leq 3.6$	-	13	ns
		Master mode $1.62 \leq V_{DD} \leq 3.6$	-	20	
$t_{su(FS)}$	$F_S$ hold time	Master mode	8	-	
$t_{h(FS)}$	$F_S$ setup time	Slave mode	1	-	
	$F_S$ hold time	Slave mode	1	-	
$t_{su(SD\_A\_MR)}$	Data input setup time	Master receiver	0.5	-	
$t_{su(SD\_B\_SR)}$		Slave receiver	1	-	
$t_{h(SD\_A\_MR)}$	Data input hold time	Master receiver	3.5	-	
$t_{h(SD\_B\_SR)}$		Slave receiver	2	-	
$t_{V(SD\_B\_ST)}$	Data output valid time	Slave transmitter (after enable edge) $2.7 \leq V_{DD} \leq 3.6$	-	14	
		Slave transmitter (after enable edge) $1.62 \leq V_{DD} \leq 3.6$	-	20	
$t_{h(SD\_B\_ST)}$	Data output hold time	Slave transmitter (after enable edge)	9	-	
$t_{V(SD\_A\_MT)}$	Data output valid time	Master transmitter (after enable edge) $2.7 \leq V_{DD} \leq 3.6$	-	12	
		Master transmitter (after enable edge) $1.62 \leq V_{DD} \leq 3.6$	-	19	
$t_{h(SD\_A\_MT)}$	Data output hold time	Master transmitter (after enable edge)	7.5	-	

1. Guaranteed by characterization results.
2. APB clock frequency must be at least twice SAI clock frequency.
3. With  $F_S=192$  kHz.

Figure 104. SAI master timing waveforms

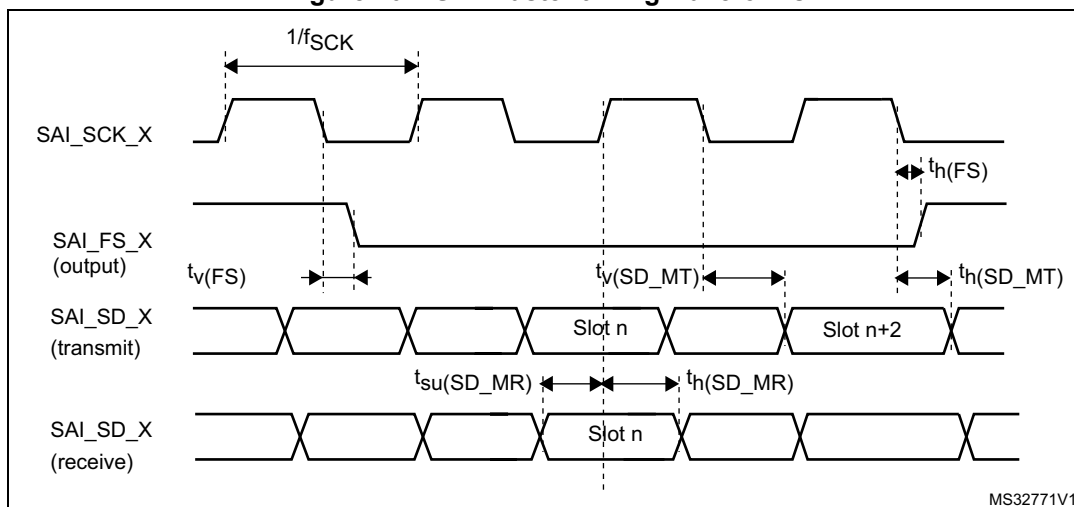

MS32771V1

Figure 105. SAI slave timing waveforms

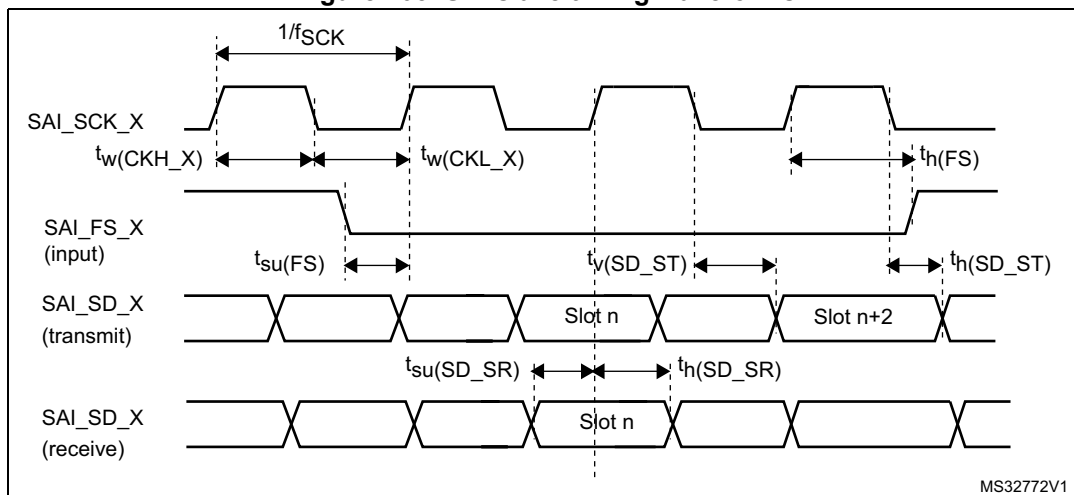

MS32772V1

MDIO characteristics

Table 206. MDIO Slave timing parameters

Symbol	Parameter	Min	Typ	Max	Unit
$F_{MDC}$	Management Data Clock	-	-	30	MHz
$t_d(MDIO)$	Management Data Input/output output valid time	8	10	19	ns
$t_{su}(MDIO)$	Management Data Input/output setup time	1	-	-	
$t_h(MDIO)$	Management Data Input/output hold time	1	-	-	

Figure 106. MDIO Slave timing diagram

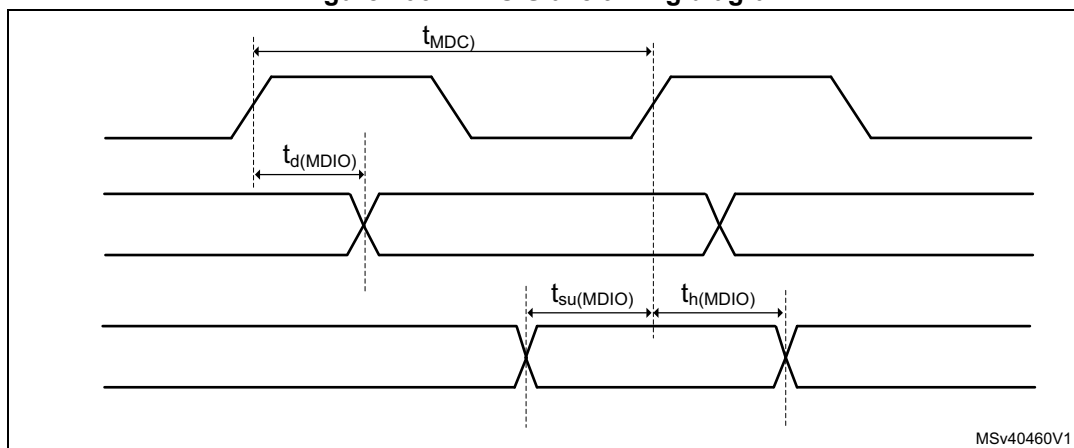

**SD/SDIO MMC card host interface (SDMMC) characteristics**

Unless otherwise specified, the parameters given in [Table 207](#) and [Table 208](#) for SDIO are derived from tests performed under the ambient temperature,  $f_{PCLKx}$  frequency and VDD supply voltage summarized in [Table 120: General operating conditions](#), with the following configuration:

- Output speed is set to OSPEEDRy[1:0] = 0x11
- Capacitive load  $C_L=30$  pF
- Measurement points are done at CMOS levels:  $0.5V_{DD}$
- IO Compensation cell activated.
- HSLV activated when  $V_{DD} \leq 2.7$  V
- VOS level set to VOS1

Refer to [Section 7.3.15: I/O port characteristics](#) for more details on the input/output characteristics.

**Table 207. Dynamics characteristics: SD / MMC characteristics,  $V_{DD}=2.7$  to  $3.6$  V<sup>(1)(2)</sup>**

Symbol	Parameter	Conditions	Min	Typ	Max	Unit
$f_{PP}$	Clock frequency in data transfer mode	-	0	-	133	MHz
-	SDIO_CK/fPCLK2 frequency ratio	-	-	-	8/3	-
$t_{W(CKL)}$	Clock low time	$f_{PP} = 52\text{MHz}$	8.5	9.5	-	ns
$t_{W(CKH)}$	Clock high time	$f_{PP} = 52\text{MHz}$	8.5	9.5	-	
<b>CMD, D inputs (referenced to CK) in eMMC legacy/SDR/DDR and SD HS/SDR<sup>(3)</sup>/DDR<sup>(3)</sup> mode</b>						
$t_{ISU}$	Input setup time HS	-	1.5	-	-	ns
$t_{IH}$	Input hold time HS	-	1.5	-	-	
$t_{IDW}^{(4)}$	Input valid window (variable window)	-	3	-	-	-
<b>CMD, D outputs (referenced to CK) in eMMC legacy/SDR/DDR and SD HS/SDR/DDR<sup>(3)</sup> mode</b>						
$t_{OV}$	Output valid time HS	-	-	3.5	5	ns
$t_{OH}$	Output hold time HS	-	2	-	-	



**Table 207. Dynamics characteristics: SD / MMC characteristics,  $V_{DD}=2.7$  to  $3.6$  V<sup>(1)(2)</sup> (continued)**

Symbol	Parameter	Conditions	Min	Typ	Max	Unit
<b>CMD, D inputs (referenced to CK) in SD default mode</b>						
$t_{ISUD}$	Input setup time SD	-	1.5		-	ns
$t_{IHD}$	Input hold time SD	-	1.5		-	
<b>CMD, D outputs (referenced to CK) in SD default mode</b>						
$t_{OVD}$	Output valid default time SD	-	-	0.5	2	ns
$t_{OHD}$	Output hold default time SD	-	0	-	-	

1. Guaranteed by characterization results.
2. Above 100 MHz,  $C_L = 20$  pF.
3. An external voltage converter is required to support SD 1.8 V.
4. The minimum window of time where the data needs to be stable for proper sampling in tuning mode.

**Table 208. Dynamics characteristics: eMMC characteristics  $V_{DD}=1.71V$  to  $1.9V$ <sup>(1)(2)</sup>**

Symbol	Parameter	Conditions	Min	Typ	Max	Unit
$f_{PP}$	Clock frequency in data transfer mode	-	0	-	120	MHz
-	SDIO_CK/fPCLK2 frequency ratio	-	-	-	8/3	-
$t_{W(CKL)}$	Clock low time	$f_{PP} = 52$ MHz	8.5	9.5	-	ns
$t_{W(CKH)}$	Clock high time	$f_{PP} = 52$ MHz	8.5	9.5	-	
<b>CMD, D inputs (referenced to CK) in eMMC mode</b>						
$t_{ISU}$	Input setup time HS	-	1	-	-	ns
$t_{IH}$	Input hold time HS	-	2.5	-	-	
$t_{IDW}^{(3)}$	Input valid window (variable window)	-	3.5	-	-	
<b>CMD, D outputs (referenced to CK) in eMMC mode</b>						
$t_{OVD}$	Output valid time HS	-	-	5	7	ns
$t_{OHD}$	Output hold time HS	-	3	-	-	

1. Guaranteed by characterization results.
2.  $C_L = 20$  pF.
3. The minimum window of time where the data needs to be stable for proper sampling in tuning mode.

Figure 107. SDIO high-speed mode

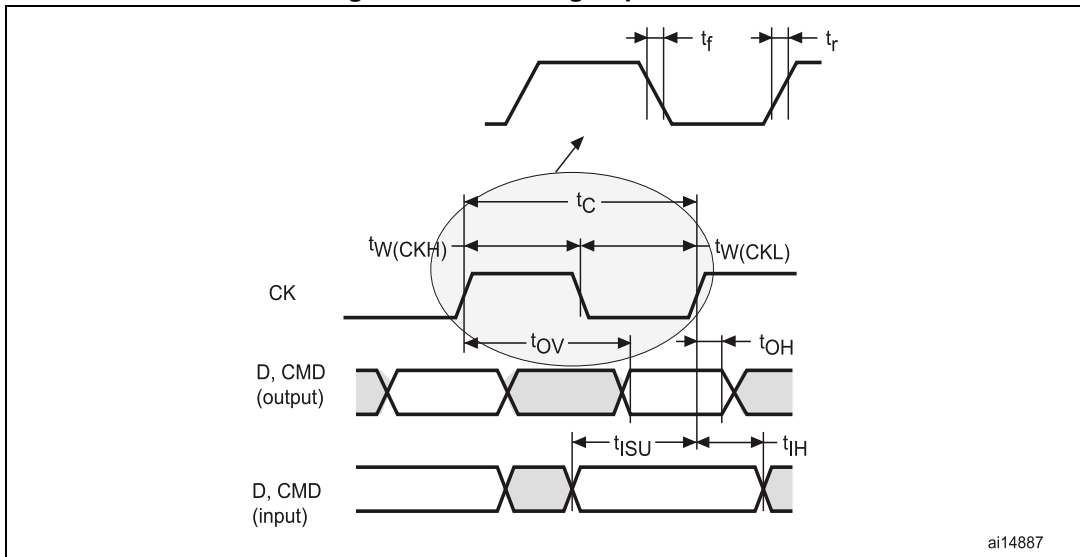

ai14887

Figure 108. SD default mode

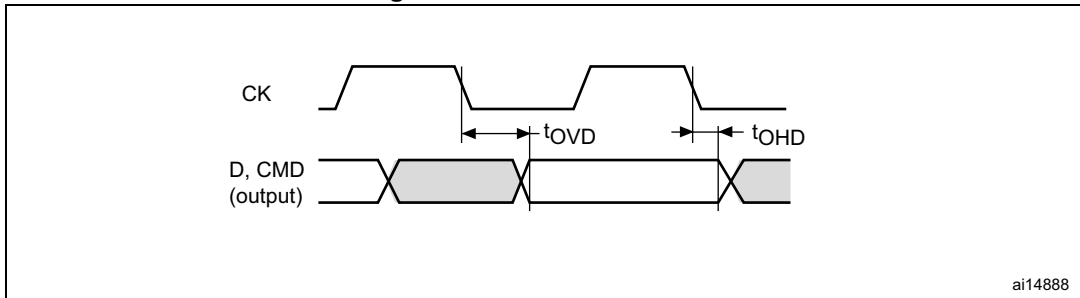

ai14888

Figure 109. DDR mode

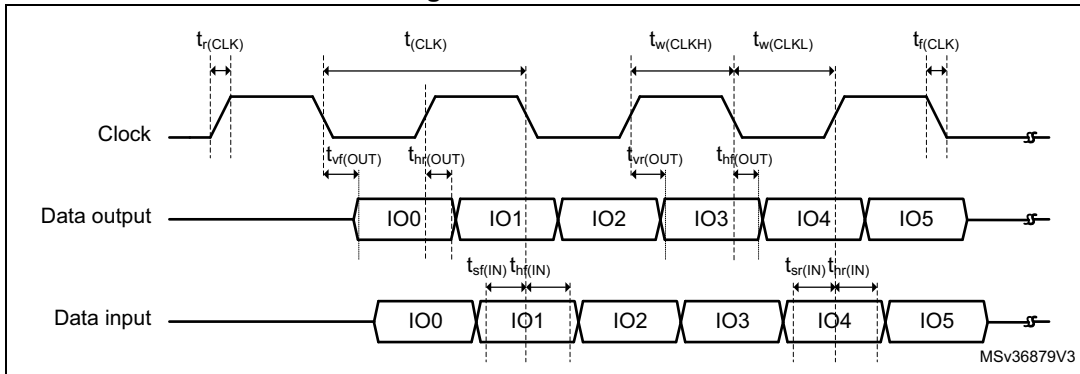

MSv36879V3

**USB OTG\_HS characteristics**

Unless otherwise specified, the parameters given in [Table 209](#) for ULPI are derived from tests performed under the ambient temperature,  $f_{PCLKx}$  frequency and  $V_{DD}$  supply voltage summarized in [Table 120: General operating conditions](#), with the following configuration:

- Output speed is set to OSPEEDRy[1:0] = 11
- Capacitive load  $C_L=20$  pF
- Measurement points are done at CMOS levels:  $0.5V_{DD}$
- IO Compensation cell activated.
- VOS level set to VOS1

Refer to [Section 7.3.15: I/O port characteristics](#) for more details on the input/output characteristics.

**Table 209. Dynamics characteristics: USB ULPI<sup>(1)</sup>**

Symbol	Parameter	Condition	Min	Typ	Max	Unit
$t_{SC}$	Control in (ULPI_DIR , ULPI_NXT) setup time	-	2.5	-	-	ns
$t_{HC}$	Control in (ULPI_DIR, ULPI_NXT) hold time	-	2	-	-	
$t_{SD}$	Data in setup time	-	2.5	-	-	
$t_{HD}$	Data in hold time	-	0	-	-	
$t_{DC}/t_{DD}$	Control/Data output delay	$2.7 < V_{DD} < 3.6$ V $C_L=20$ pF	-	9	9.5	
		$1.71 < V_{DD} < 3.6$ V $C_L=15$ pF	-	9	14	

1. Guaranteed by characterization results.

**Figure 110. ULPI timing diagram**

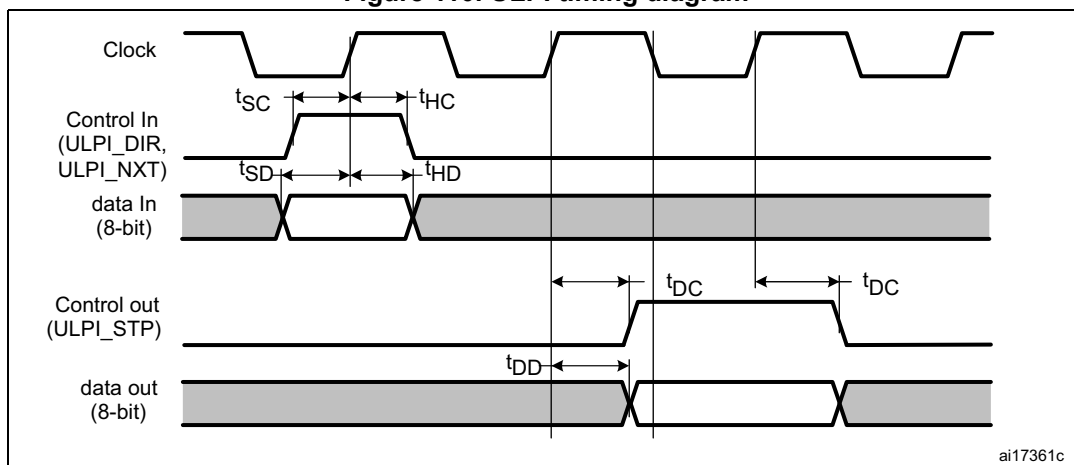

**Ethernet interface characteristics**

Unless otherwise specified, the parameters given in [Table 210](#), [Table 211](#) and [Table 212](#) for SMI, RMII and MII are derived from tests performed under the ambient temperature,  $f_{\text{rcc\_c\_ck}}$  frequency and  $V_{\text{DD}}$  supply voltage conditions summarized in [Table 120: General operating conditions](#), with the following configuration:

- Output speed is set to OSPEEDRy[1:0] = 10
- Capacitive load  $C_L=20$  pF
- Measurement points are done at CMOS levels:  $0.5V_{\text{DD}}$
- IO Compensation cell activated.
- HSLV activated when  $V_{\text{DD}} \leq 2.7$  V
- VOS level set to VOS1

Refer to [Section 7.3.15: I/O port characteristics](#) for more details on the input/output characteristics:

**Table 210. Dynamics characteristics: Ethernet MAC signals for SMI <sup>(1)</sup>**

Symbol	Parameter	Min	Typ	Max	Unit
$t_{\text{MDC}}$	MDC cycle time( 2.5 MHz)	400	400	403	ns
$T_{\text{d}}(\text{MDIO})$	Write data valid time	0.5	1.5	4	
$t_{\text{su}}(\text{MDIO})$	Read data setup time	12.5	-	-	
$t_{\text{h}}(\text{MDIO})$	Read data hold time	0	-	-	

1. Guaranteed by characterization results.

**Figure 111. Ethernet SMI timing diagram**

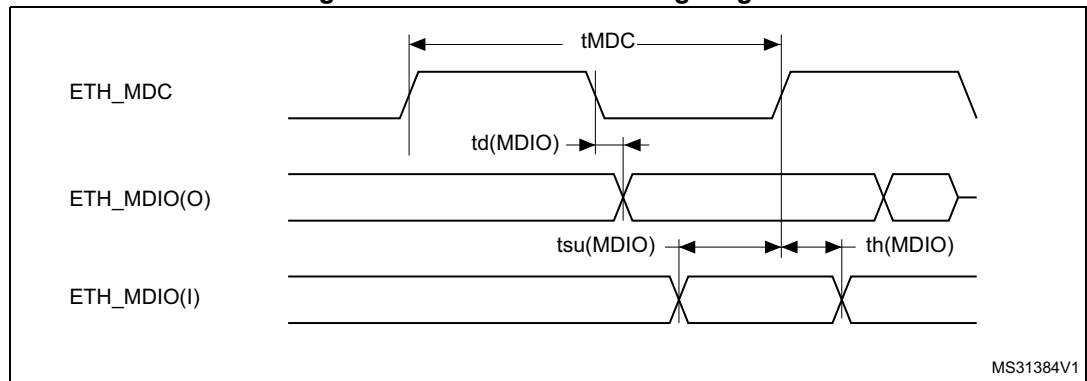
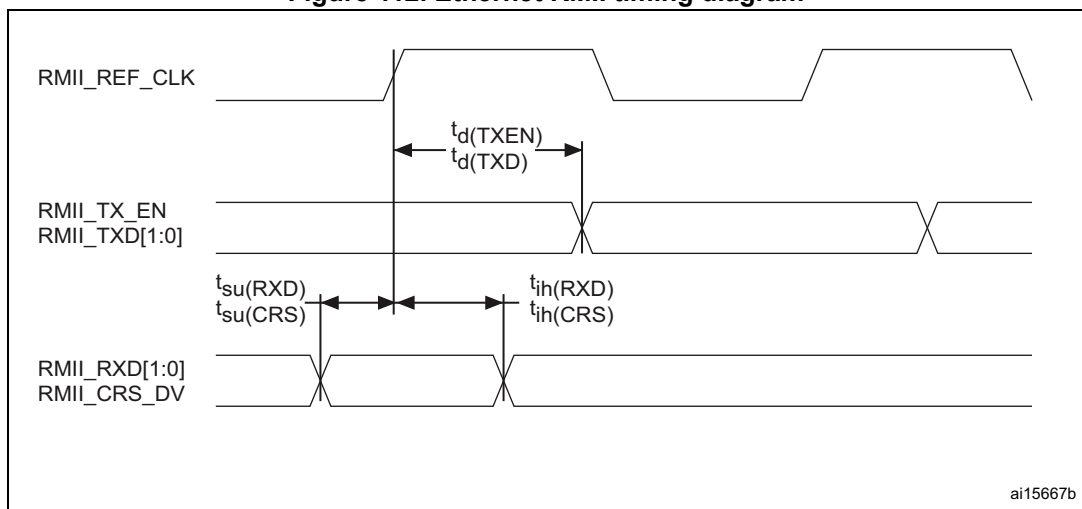

**Table 211. Dynamics characteristics: Ethernet MAC signals for RMII (1)**

Symbol	Parameter	Min	Typ	Max	Unit
$t_{su}(RXD)$	Receive data setup time	2	-	-	ns
$t_{ih}(RXD)$	Receive data hold time	2	-	-	
$t_{su}(CRS)$	Carrier sense setup time	1.5	-	-	
$t_{ih}(CRS)$	Carrier sense hold time	1.5	-	-	
$t_d(TXEN)$	Transmit enable valid delay time	7	8	9.5	
$t_d(TXD)$	Transmit data valid delay time	8	9	11	

1. Guaranteed by characterization results.

**Figure 112. Ethernet RMII timing diagram**



ai15667b

**Table 212. Dynamics characteristics: Ethernet MAC signals for MII (1)**

Symbol	Parameter	Min	Typ	Max	Unit
$t_{su}(RXD)$	Receive data setup time	2	-	-	ns
$t_{ih}(RXD)$	Receive data hold time	2	-	-	
$t_{su}(DV)$	Data valid setup time	1.5	-	-	
$t_{ih}(DV)$	Data valid hold time	1.5	-	-	
$t_{su}(ER)$	Error setup time	1.5	-	-	
$t_{ih}(ER)$	Error hold time	0.5	-	-	
$t_d(TXEN)$	Transmit enable valid delay time	9	10	11	
$t_d(TXD)$	Transmit data valid delay time	8.5	9.5	12.5	

1. Guaranteed by characterization results.

Figure 113. Ethernet MII timing diagram

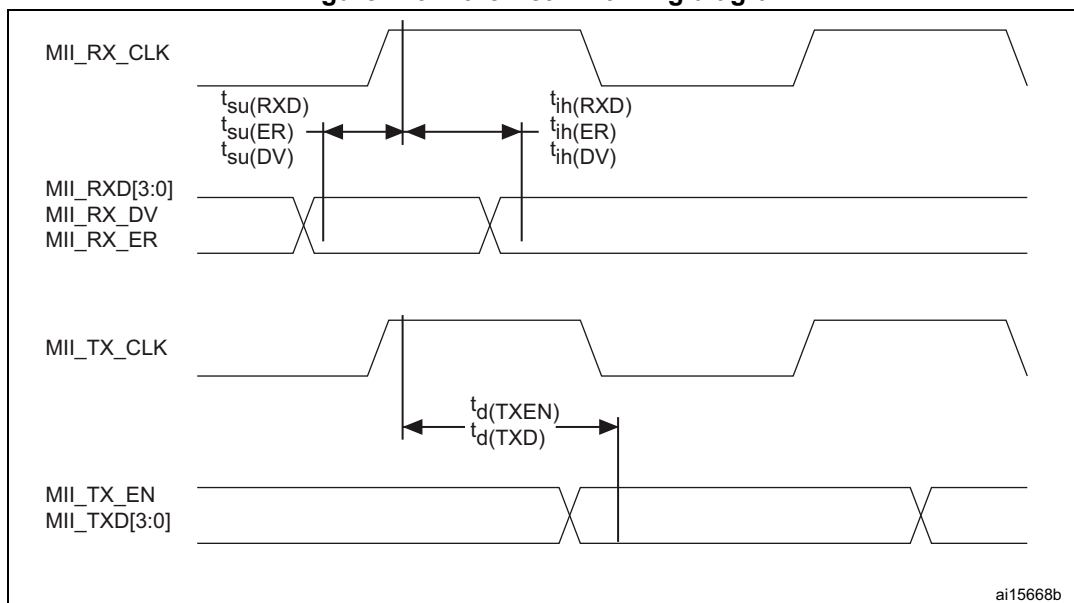

### JTAG/SWD interface characteristics

Unless otherwise specified, the parameters given in [Table 213](#) and [Table 214](#) for JTAG/SWD are derived from tests performed under the ambient temperature,  $f_{rcc\_c\_ck}$  frequency and  $V_{DD}$  supply voltage summarized in [Table 120: General operating conditions](#), with the following configuration:

- Output speed is set to  $OSPEEDRy[1:0] = 0x10$
- Capacitive load  $C_L = 30$  pF
- Measurement points are done at CMOS levels:  $0.5V_{DD}$
- VOS level set to VOS1

Refer to [Section 7.3.15: I/O port characteristics](#) for more details on the input/output characteristics:

Table 213. Dynamics JTAG characteristics

Symbol	Parameter	Conditions	Min	Typ	Max	Unit
$F_{pp}$	T <sub>CK</sub> clock frequency	$2.7V < V_{DD} < 3.6 V$	-	-	37	MHz
$1/t_c(TCK)$		$1.62 < V_{DD} < 3.6 V$	-	-	27.5	
$t_{su}(TMS)$	TMS input setup time	-	2.5	-	-	
$t_{ih}(TMS)$	TMS input hold time	-	1	-	-	
$t_{su}(TDI)$	TDI input setup time	-	1.5	-	-	-
$t_{ih}(TDI)$	TDI input hold time	-	1	-	-	-
$t_{ov}(TDO)$	TDO output valid time	$2.7V < V_{DD} < 3.6 V$	-	8	13.5	-
		$1.62 < V_{DD} < 3.6 V$	-	8	18	-
$t_{oh}(TDO)$	TDO output hold time	-	7	-	-	-

Table 214. Dynamics SWD characteristics:

Symbol	Parameter	Conditions	Min	Typ	Max	Unit
$F_{pp}$	SWCLK clock frequency	$2.7V < V_{DD} < 3.6 V$	-	-	71	MHz
$1/t_c(SWCLK)$		$1.62 < V_{DD} < 3.6 V$	-	-	52.5	
$t_{i_{su}}(SWDIO)$	SWDIO input setup time	-	2.5	-	-	-
$t_{i_h}(SWDIO)$	SWDIO input hold time	-	1	-	-	-
$t_{ov}(SWDIO)$	SWDIO output valid time	$2.7V < V_{DD} < 3.6 V$	-	8.5	14	-
		$1.62 < V_{DD} < 3.6 V$	-	8.5	19	-
$t_{oh}(SWDIO)$	SWDIO output hold time	-	8	-	-	-

Figure 114. JTAG timing diagram

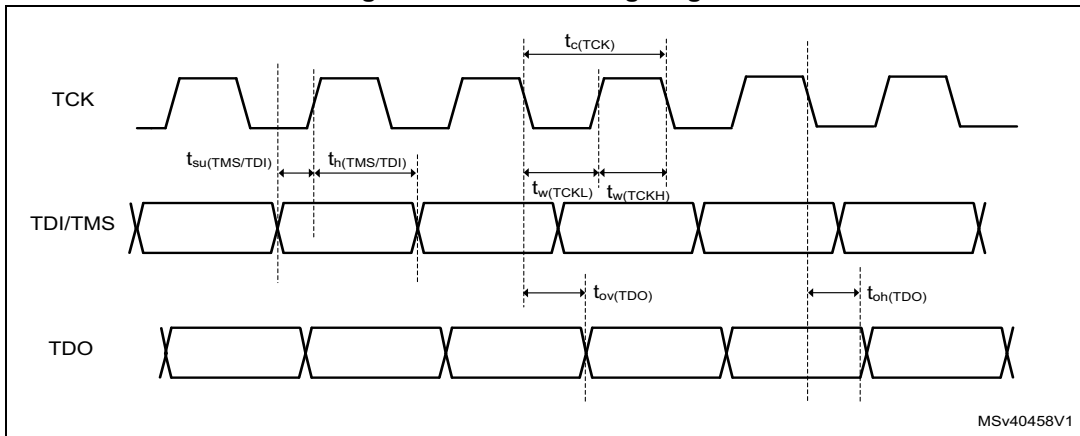

MSv40458V1

Figure 115. SWD timing diagram

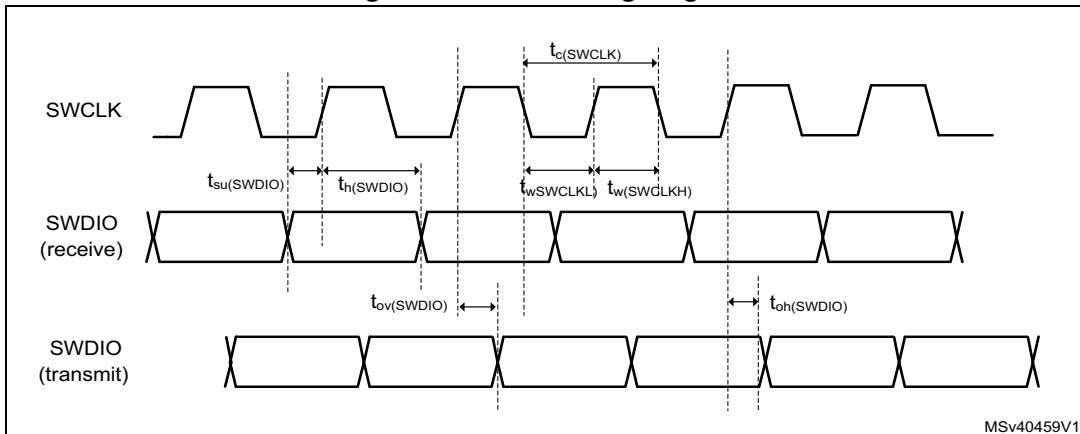

MSv40459V1

## 8 Package information

In order to meet environmental requirements, ST offers these devices in different grades of ECOPACK packages, depending on their level of environmental compliance. ECOPACK specifications, grade definitions and product status *are available at [www.st.com](http://www.st.com)*. ECOPACK is an ST trademark.

### 8.1 LQFP100 package information

LQFP100 is a 100-pin, 14 x 14 mm low-profile quad flat package.

Figure 116. LQFP100 package outline

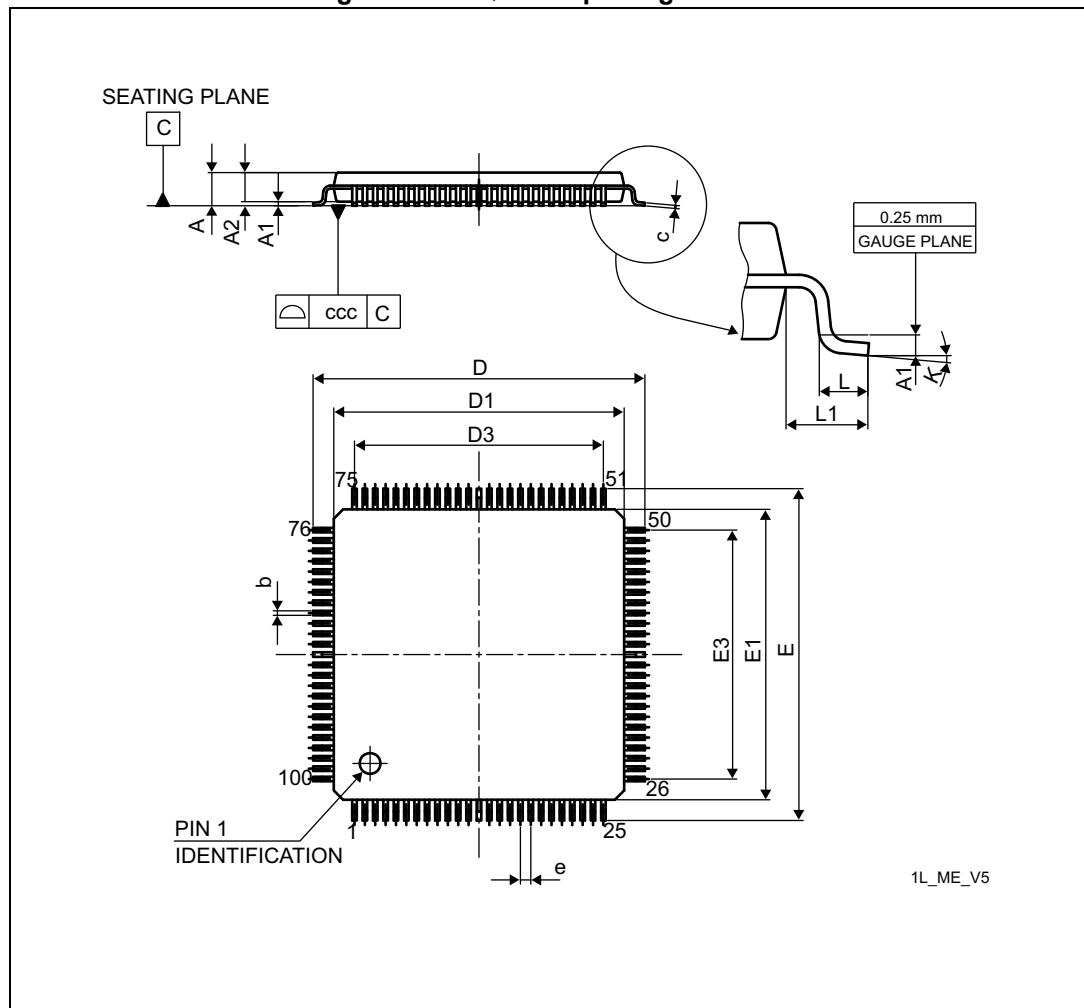

1. Drawing is not to scale.

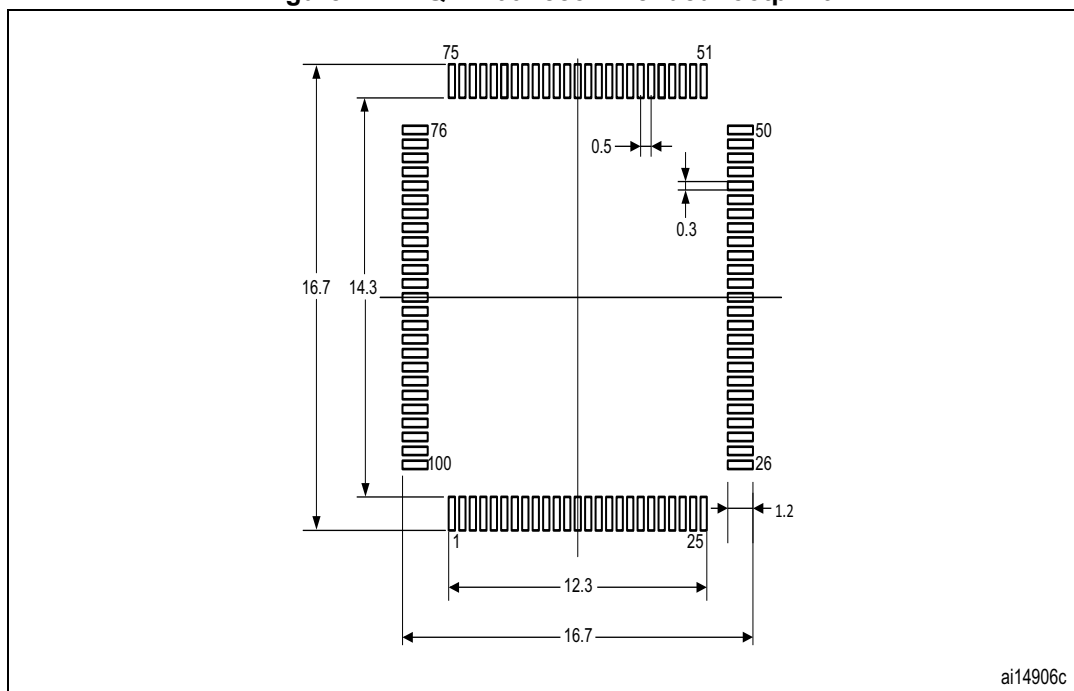

Table 215. LQPF100 package mechanical data

Symbol	millimeters			inches <sup>(1)</sup>		
	Min	Typ	Max	Min	Typ	Max
A	-	-	1.600	-	-	0.0630
A1	0.050	-	0.150	0.0020	-	0.0059
A2	1.350	1.400	1.450	0.0531	0.0551	0.0571
b	0.170	0.220	0.270	0.0067	0.0087	0.0106
c	0.090	-	0.200	0.0035	-	0.0079
D	15.800	16.000	16.200	0.6220	0.6299	0.6378
D1	13.800	14.000	14.200	0.5433	0.5512	0.5591
D3	-	12.000	-	-	0.4724	-
E	15.800	16.000	16.200	0.6220	0.6299	0.6378
E1	13.800	14.000	14.200	0.5433	0.5512	0.5591
E3	-	12.000	-	-	0.4724	-
e	-	0.500	-	-	0.0197	-
L	0.450	0.600	0.750	0.0177	0.0236	0.0295
L1	-	1.000	-	-	0.0394	-
k	0.0°	3.5°	7.0°	0.0°	3.5°	7.0°
ccc	-	-	0.080	-	-	0.0031

1. Values in inches are converted from mm and rounded to 4 decimal digits.

Figure 117. LQFP100 recommended footprint



1. Dimensions are expressed in millimeters.

**Device marking for LQFP100**

The following figure gives an example of topside marking versus pin 1 position identifier location.

The printed markings may differ depending on the supply chain.

Other optional marking or inset/upset marks, which depend on supply chain operations, are not indicated below.

**Figure 118. LQFP100 marking example (package top view)**

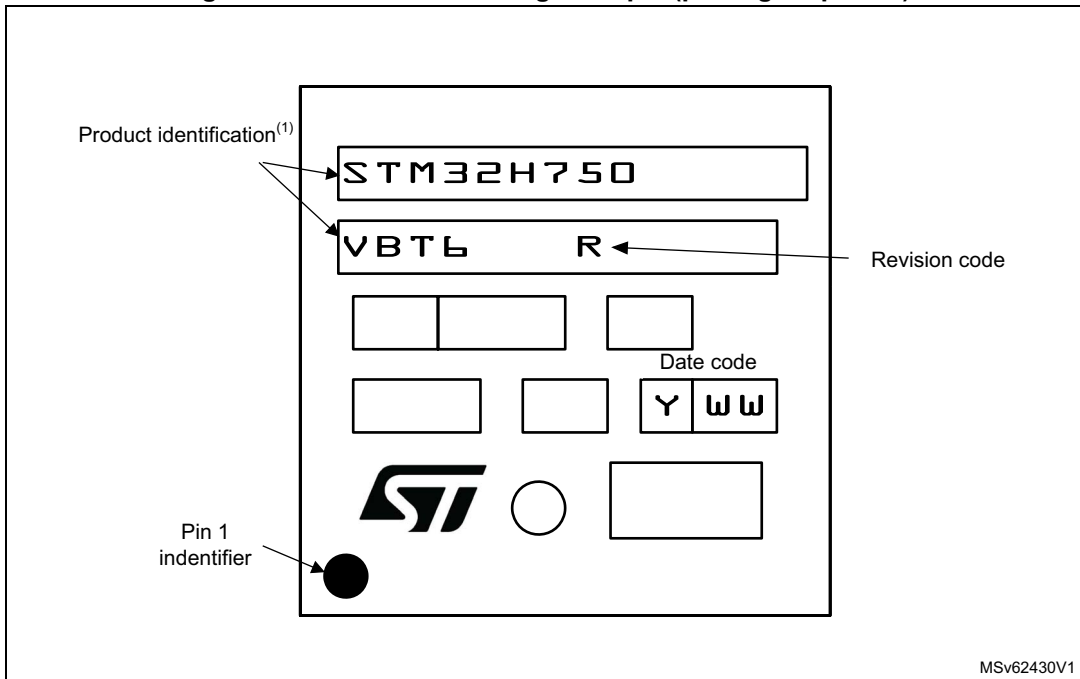

1. Parts marked as "ES", "E" or accompanied by an Engineering Sample notification letter, are not yet qualified and therefore not approved for use in production. ST is not responsible for any consequences resulting from such use. In no event will ST be liable for the customer using any of these engineering samples in production. ST's Quality department must be contacted prior to any decision to use these engineering samples to run a qualification activity.

## 8.2 LQFP144 package information

LQFP144 is a 144-pin, 20 x 20 mm low-profile quad flat package.

Figure 119. LQFP144 package outline

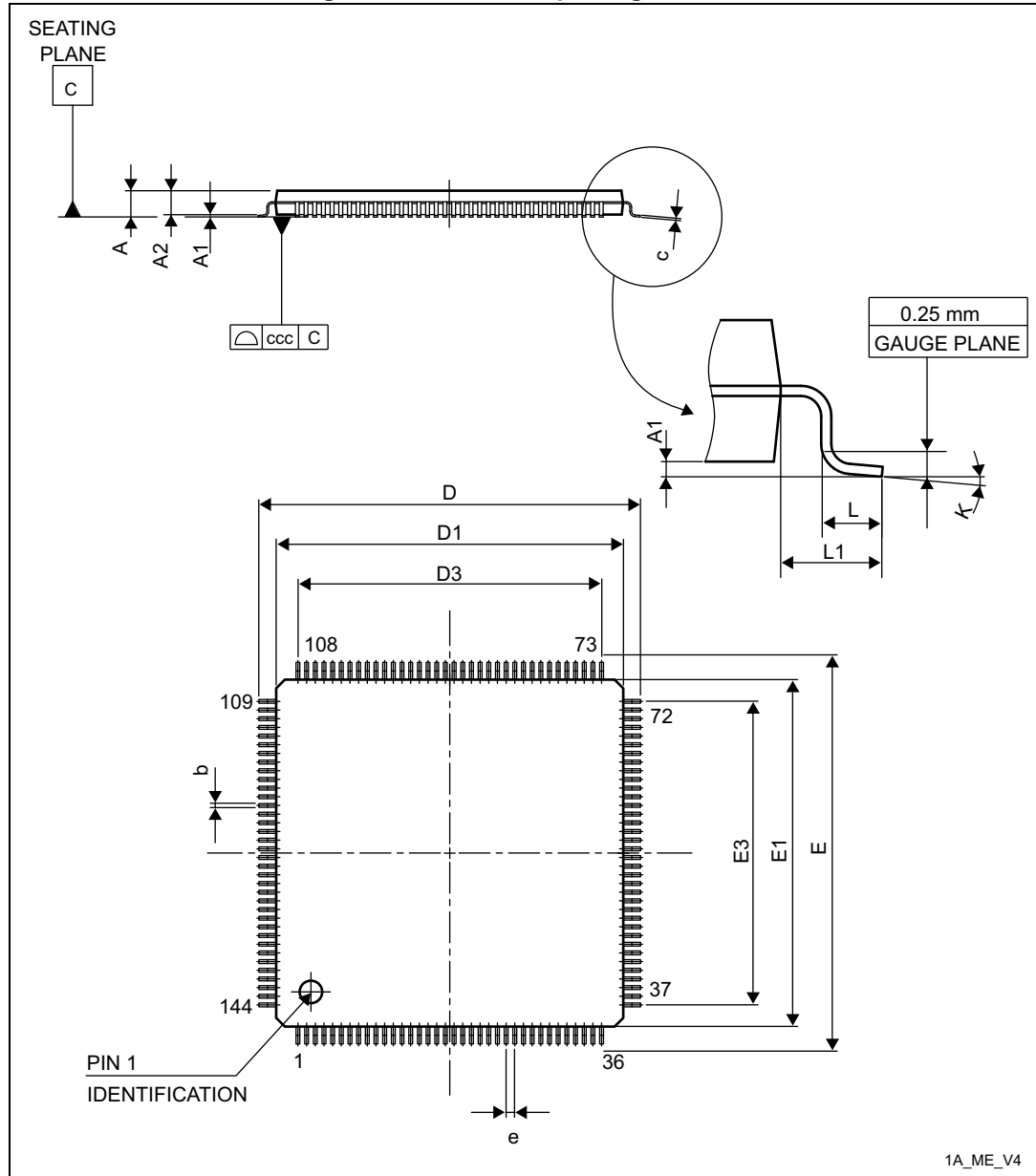

1. Drawing is not to scale.

Table 216. LQFP144 package mechanical data

Symbol	millimeters			inches <sup>(1)</sup>		
	Min	Typ	Max	Min	Typ	Max
A	-	-	1.600	-	-	0.0630
A1	0.050	-	0.150	0.0020	-	0.0059
A2	1.350	1.400	1.450	0.0531	0.0551	0.0571
b	0.170	0.220	0.270	0.0067	0.0087	0.0106
c	0.090	-	0.200	0.0035	-	0.0079
D	21.800	22.000	22.200	0.8583	0.8661	0.8740
D1	19.800	20.000	20.200	0.7795	0.7874	0.7953
D3	-	17.500	-	-	0.6890	-
E	21.800	22.000	22.200	0.8583	0.8661	0.8740
E1	19.800	20.000	20.200	0.7795	0.7874	0.7953
E3	-	17.500	-	-	0.6890	-
e	-	0.500	-	-	0.0197	-
L	0.450	0.600	0.750	0.0177	0.0236	0.0295
L1	-	1.000	-	-	0.0394	-
k	0°	3.5°	7°	0°	3.5°	7°
ccc	-	-	0.080	-	-	0.0031

1. Values in inches are converted from mm and rounded to 4 decimal digits.

Figure 120. LQFP144 package recommended footprint

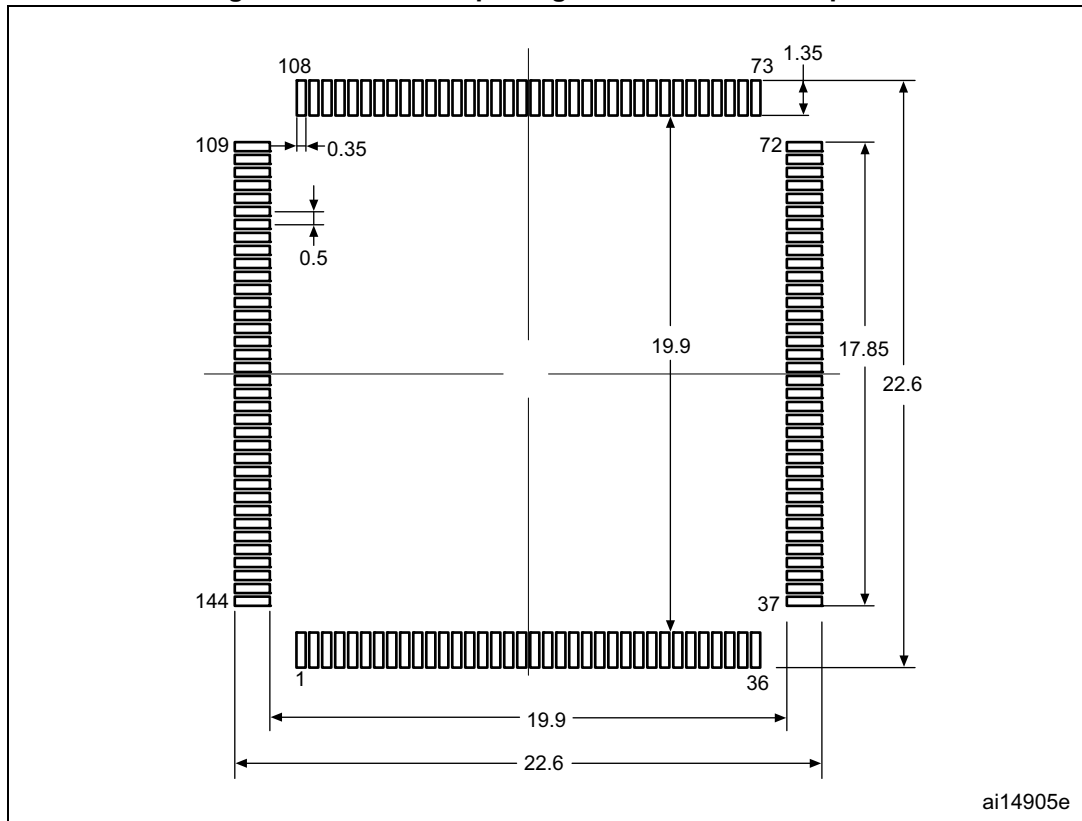

ai14905e

1. Dimensions are expressed in millimeters.

**Device marking for LQFP144**

The following figure gives an example of topside marking versus pin 1 position identifier location.

The printed markings may differ depending on the supply chain.

Other optional marking or inset/upset marks, which depend on supply chain operations, are not indicated below.

**Figure 121. LQFP144 marking example (package top view)**

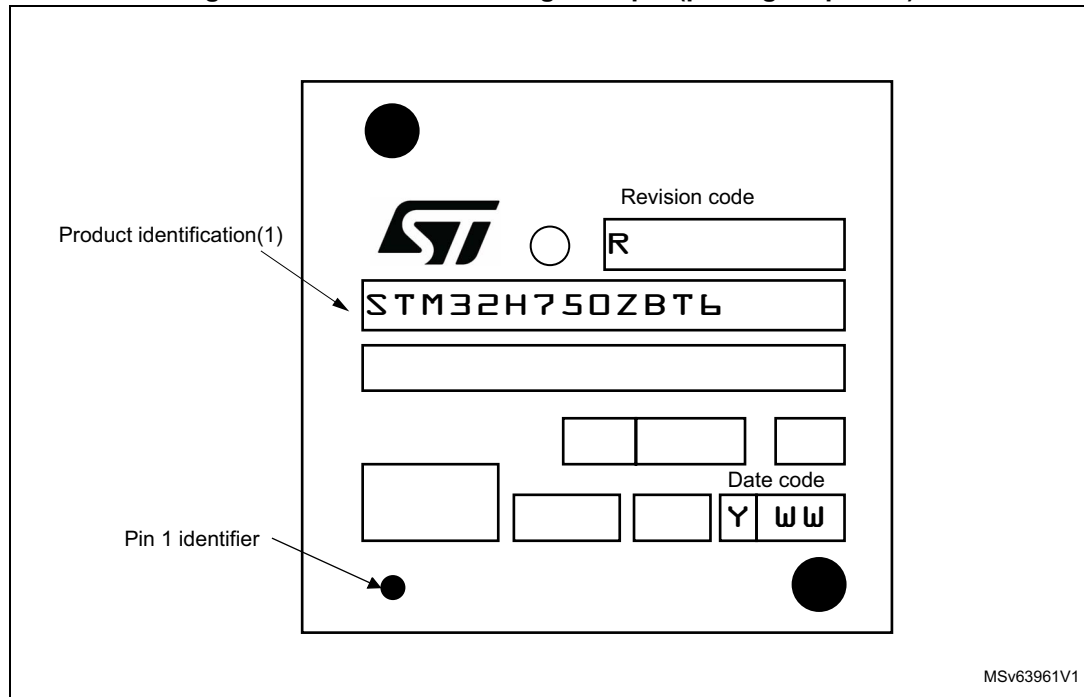

1. Parts marked as “ES”, “E” or accompanied by an Engineering Sample notification letter, are not yet qualified and therefore not approved for use in production. ST is not responsible for any consequences resulting from such use. In no event will ST be liable for the customer using any of these engineering samples in production. ST’s Quality department must be contacted prior to any decision to use these engineering samples to run a qualification activity.

### 8.3 LQFP176 package information

LQFP176 is a 176-pin, 24 x 24 mm low profile quad flat package.

Figure 122. LQFP176 package outline

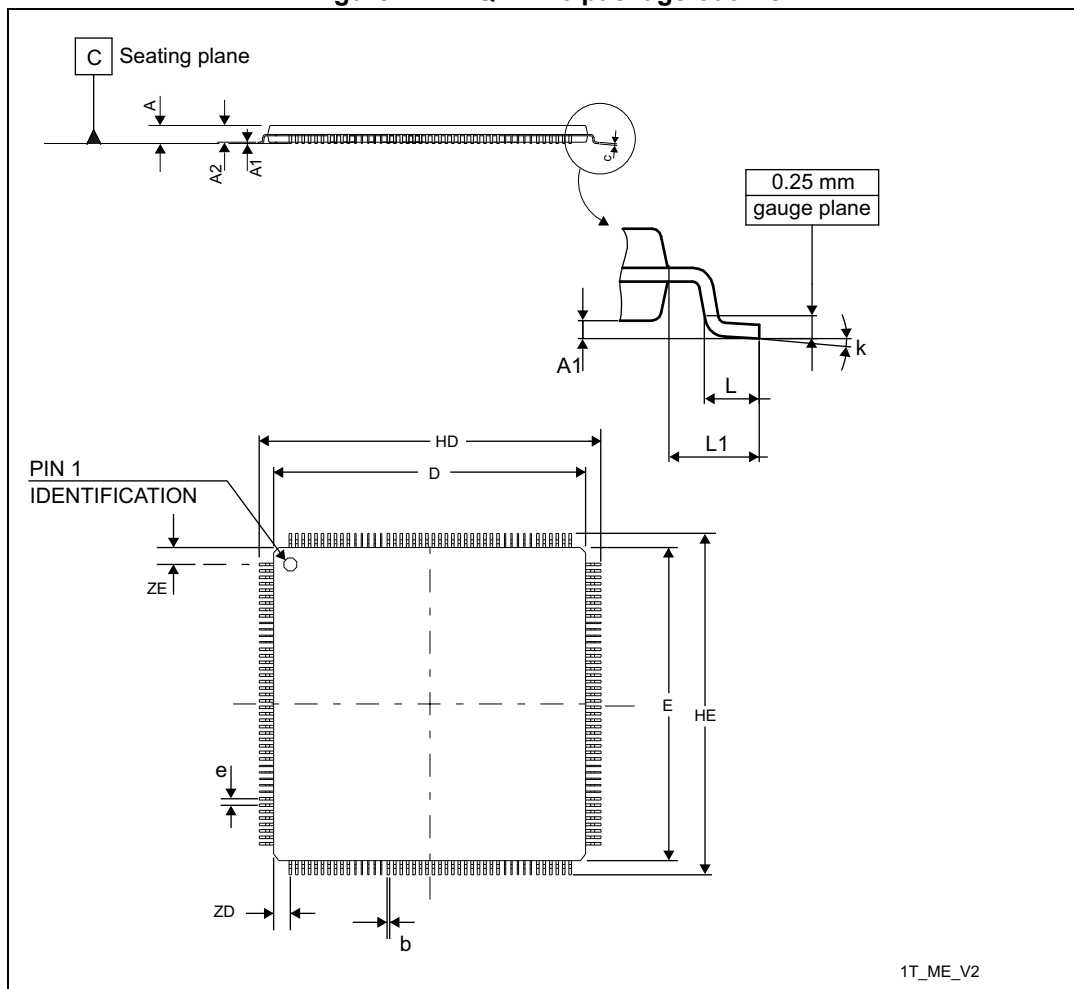

1. Drawing is not to scale.

Table 217. LQFP176 package mechanical data

Ref.	Dimensions					
	Millimeters			Inches <sup>(1)</sup>		
	Min.	Typ.	Max.	Min.	Typ.	Max.
A	-	-	1.600	-	-	0.0630
A1	0.050	-	0.150	0.0020	-	0.0059
A2	1.350	-	1.450	0.0531	-	0.0571
b	0.170	-	0.270	0.0067	-	0.0106
c	0.090	-	0.200	0.0035	-	0.0079



Table 217. LQFP176 package mechanical data (continued)

Ref.	Dimensions					
	Millimeters			Inches <sup>(1)</sup>		
	Min.	Typ.	Max.	Min.	Typ.	Max.
D	23.900	-	24.100	0.9409	-	0.9488
HD	25.900	-	26.100	1.0197	-	1.0276
ZD	-	1.250	-	-	0.0492	-
E	23.900	-	24.100	0.9409	-	0.9488
HE	25.900	-	26.100	1.0197	-	1.0276
ZE	-	1.250	-	-	0.0492	-
e	-	0.500	-	-	0.0197	-
L <sup>(2)</sup>	0.450	-	0.750	0.0177	-	0.0295
L1	-	1.000	-	-	0.0394	-
k	0°	-	7°	0°	-	7°
ccc	-	-	0.080	-	-	0.0031

1. Values in inches are converted from mm and rounded to 4 decimal digits.

2. L dimension is measured at gauge plane at 0.25 mm above the seating plane.

Figure 123. LQFP176 package recommended footprint

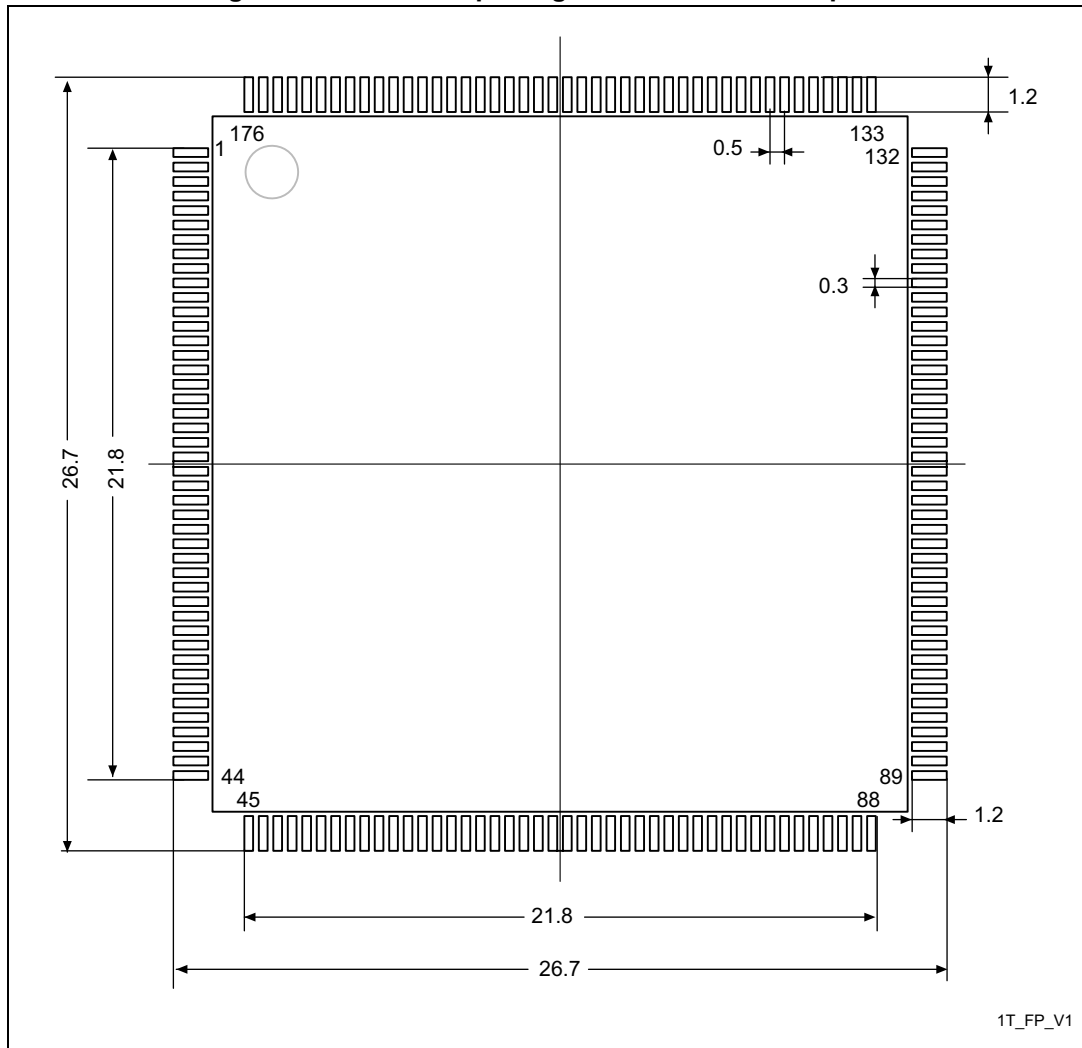

1. Dimensions are expressed in millimeters.

**Device marking for LQFP176**

The following figure gives an example of topside marking versus pin 1 position identifier location.

The printed markings may differ depending on the supply chain.

Other optional marking or inset/upset marks, which depend on supply chain operations, are not indicated below.

**Figure 124. LQFP176 marking example (package top view)**

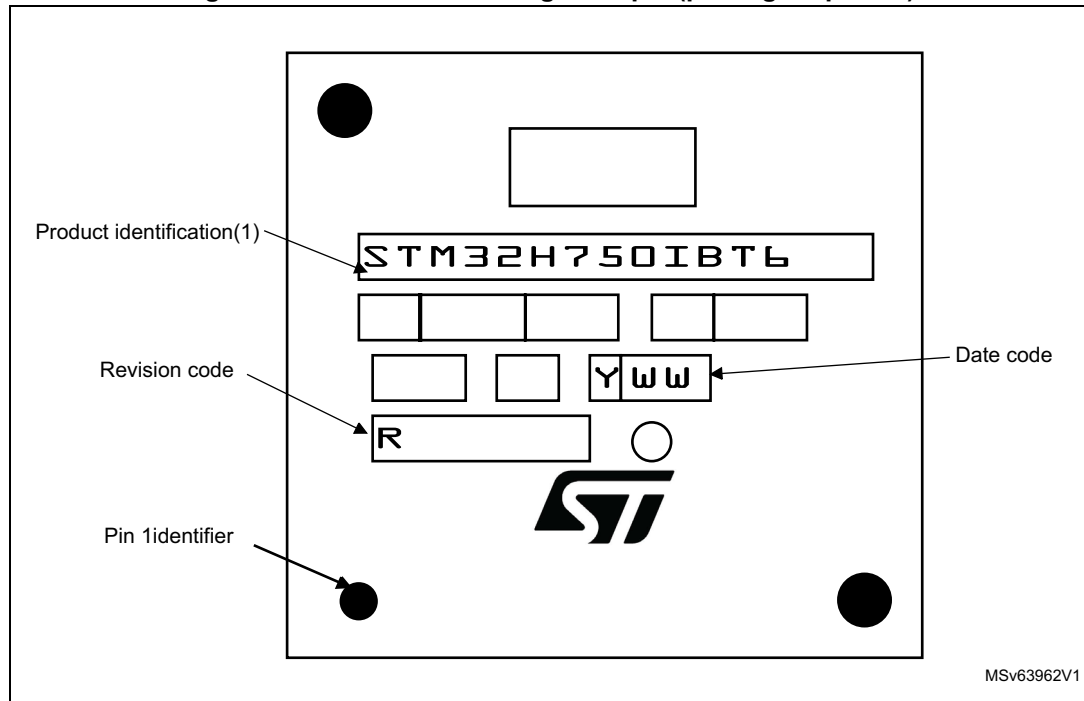

1. Parts marked as “ES”, “E” or accompanied by an Engineering Sample notification letter, are not yet qualified and therefore not approved for use in production. ST is not responsible for any consequences resulting from such use. In no event will ST be liable for the customer using any of these engineering samples in production. ST’s Quality department must be contacted prior to any decision to use these engineering samples to run a qualification activity.

### 8.4 UFBGA176+25 package information

UFBGA176+25 is a 201-ball, 10 x 10 mm, 0.65 mm pitch, ultra fine pitch ball grid array package.

Figure 125. UFBGA176+25 package outline

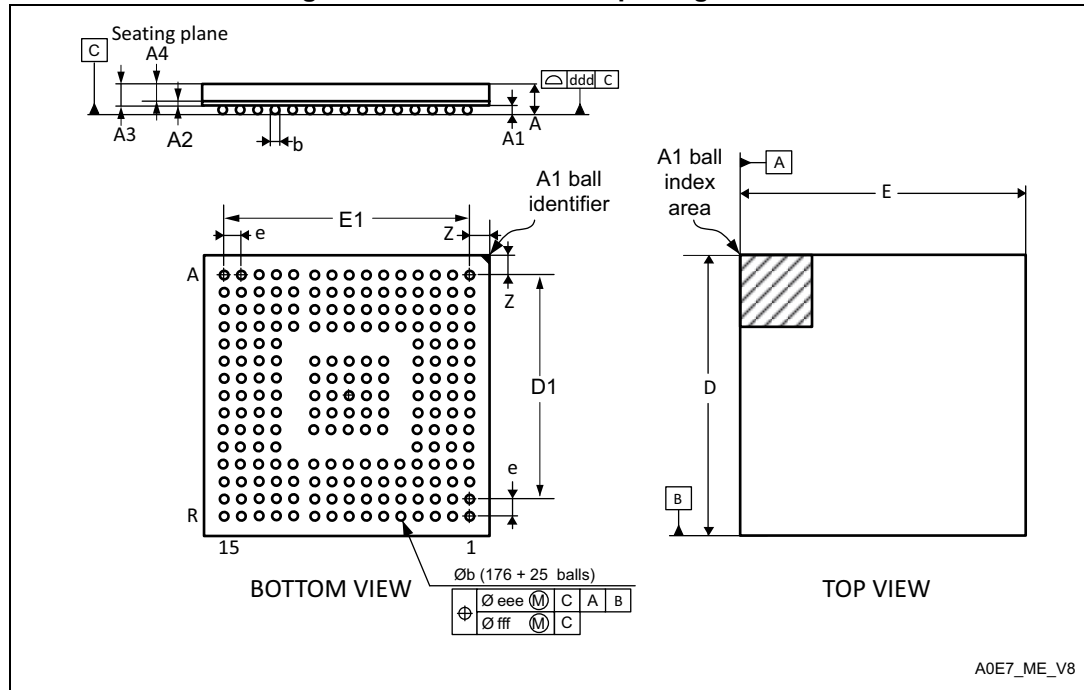

1. Drawing is not to scale.

Table 218. UFBGA176+25 package mechanical data

Symbol	millimeters			inches <sup>(1)</sup>		
	Min.	Typ.	Max.	Min.	Typ.	Max.
A	-	-	0.600	-	-	0.0236
A1	-	-	0.110	-	-	0.0043
A2	-	0.130	-	-	0.0051	-
A3	-	0.450	-	-	0.0177	-
A4	-	0.320	-	-	0.0126	-
b	0.240	0.290	0.340	0.0094	0.0114	0.0134
D	9.850	10.000	10.150	0.3878	0.3937	0.3996
D1	-	9.100	-	-	0.3583	-
E	9.850	10.000	10.150	0.3878	0.3937	0.3996
E1	-	9.100	-	-	0.3583	-
e	-	0.650	-	-	0.0256	-
Z	-	0.450	-	-	0.0177	-
ddd	-	-	0.080	-	-	0.0031

**Table 218. UFBGA176+25 package mechanical data (continued)**

Symbol	millimeters			inches <sup>(1)</sup>		
	Min.	Typ.	Max.	Min.	Typ.	Max.
eee	-	-	0.150	-	-	0.0059
fff	-	-	0.050	-	-	0.0020

1. Values in inches are converted from mm and rounded to 4 decimal digits.

**Figure 126. UFBGA176+25 package recommended footprint**

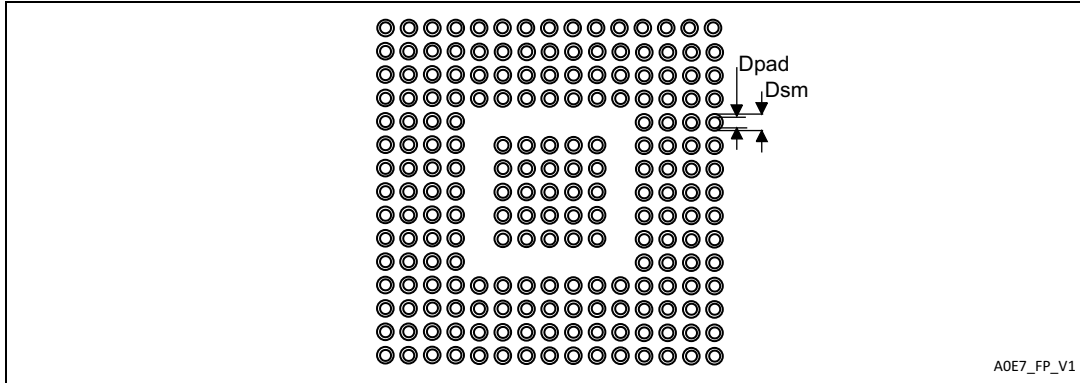

**Table 219. UFBGA176+25 recommended PCB design rules (0.65 mm pitch BGA)**

Dimension	Recommended values
Pitch	0.65 mm
Dpad	0.300 mm
Dsm	0.400 mm typ. (depends on the soldermask registration tolerance)
Stencil opening	0.300 mm
Stencil thickness	Between 0.100 mm and 0.125 mm
Pad trace width	0.100 mm

**Device marking for UFBGA176+25**

The following figure gives an example of topside marking versus pin 1 position identifier location.

The printed markings may differ depending on the supply chain.

Other optional marking or inset/upset marks, which depend on supply chain operations, are not indicated below.

**Figure 127. UFBGA176+25 marking example (package top view)**

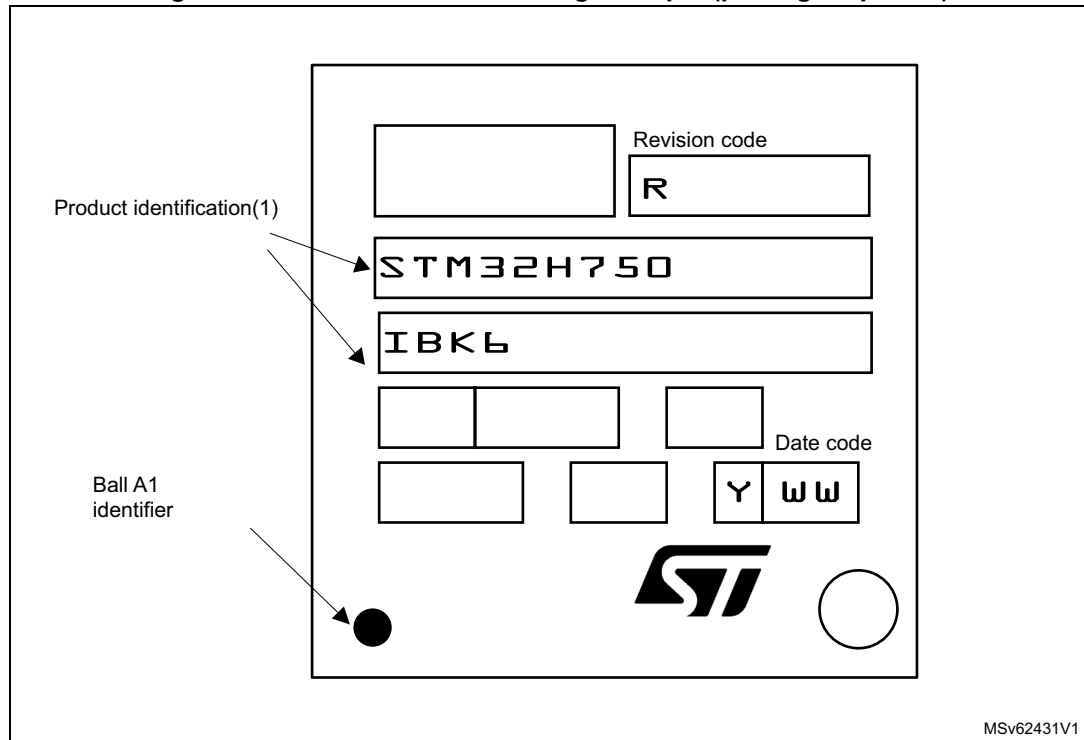

1. Parts marked as "ES", "E" or accompanied by an Engineering Sample notification letter, are not yet qualified and therefore not approved for use in production. ST is not responsible for any consequences resulting from such use. In no event will ST be liable for the customer using any of these engineering samples in production. ST's Quality department must be contacted prior to any decision to use these engineering samples to run a qualification activity.

### 8.5 TFBGA240+25 package information

TFBGA240+25 is a 265 ball, 14x14 mm, 0.8 mm pitch, fine pitch ball grid array package.

Figure 128. TFBGA240+25 package outline

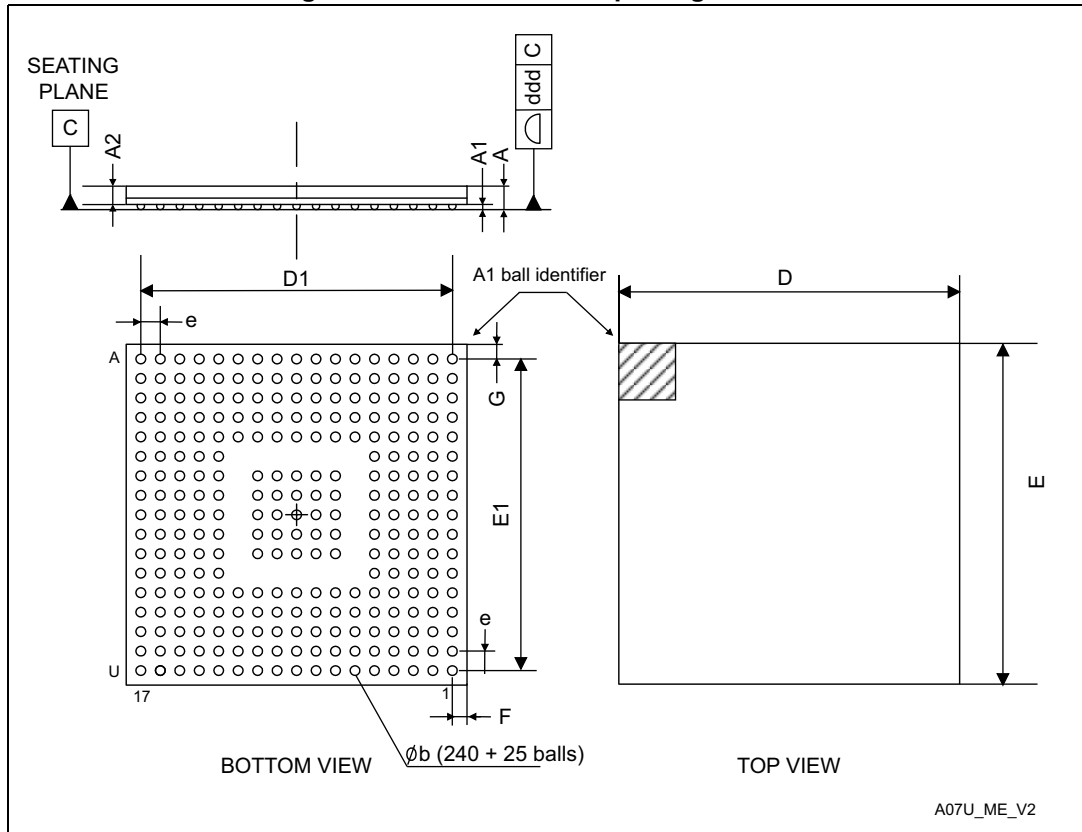

1. Dimensions are expressed in millimeters.

Table 220. TFBG240+25 ball package mechanical data

Symbol	millimeters			inches <sup>(1)</sup>		
	Min	Typ	Max	Min	Typ	Max
A	-	-	1.100	-	-	0.0433
A1	0.150	-	-	0.0059	-	-
A2	-	0.760	-	-	0.0299	-
b	0.350	0.400	0.450	0.0138	0.0157	0.0177
D	13.850	14.000	14.150	0.5453	0.5512	0.5571
D1	-	12.800	-	-	0.5039	-
E	13.850	14.000	14.150	0.5453	0.5512	0.5571
E1	-	12.800	-	-	0.5039	-
e	-	0.800	-	-	0.0315	-
F	-	0.600	-	-	0.0236	-
G	-	0.600	-	-	0.0236	-
ddd	-	-	0.100	-	-	0.0039
eee	-	-	0.150	-	-	0.0059
fff	-	-	0.080	-	-	0.0031

1. Values in inches are converted from mm and rounded to 4 decimal digits.

Figure 129. TFBGA240+25 package recommended footprint

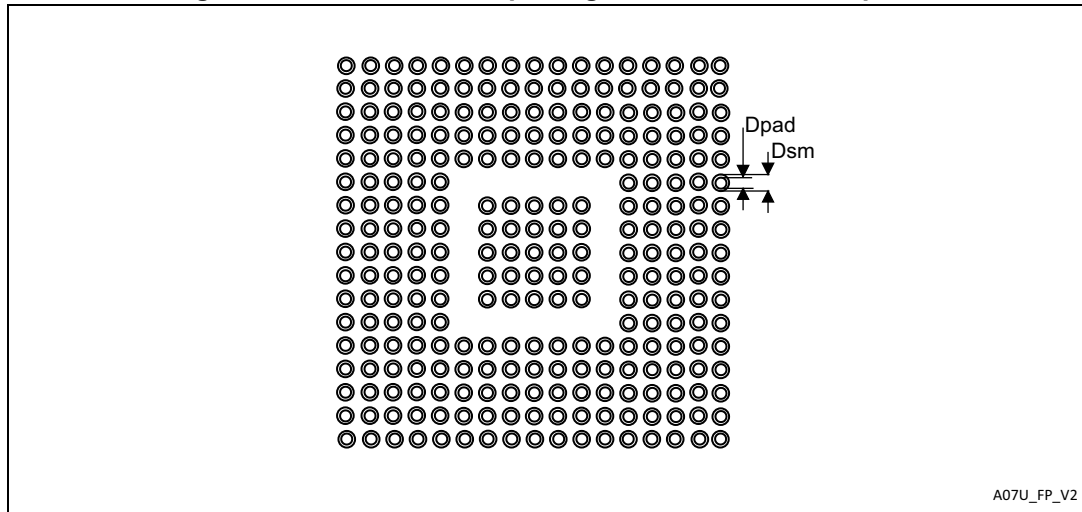

1. Dimensions are expressed in millimeters.



**Table 221. TFBGA240+25 recommended PCB design rules (0.8 mm pitch)**

Dimension	Recommended values
Pitch	0.8 mm
Dpad	0.225 mm
Dsm	0.290 mm typ. (depends on the soldermask registration tolerance)
Stencil opening	0.250 mm
Stencil thickness	0.100 mm

**Device marking for TFBGA240+25**

The following figure gives an example of topside marking versus pin 1 position identifier location.

The printed markings may differ depending on the supply chain.

Other optional marking or inset/upset marks, which depend on supply chain operations, are not indicated below.

**Figure 130. TFBGA240+25 marking example (package top view)**

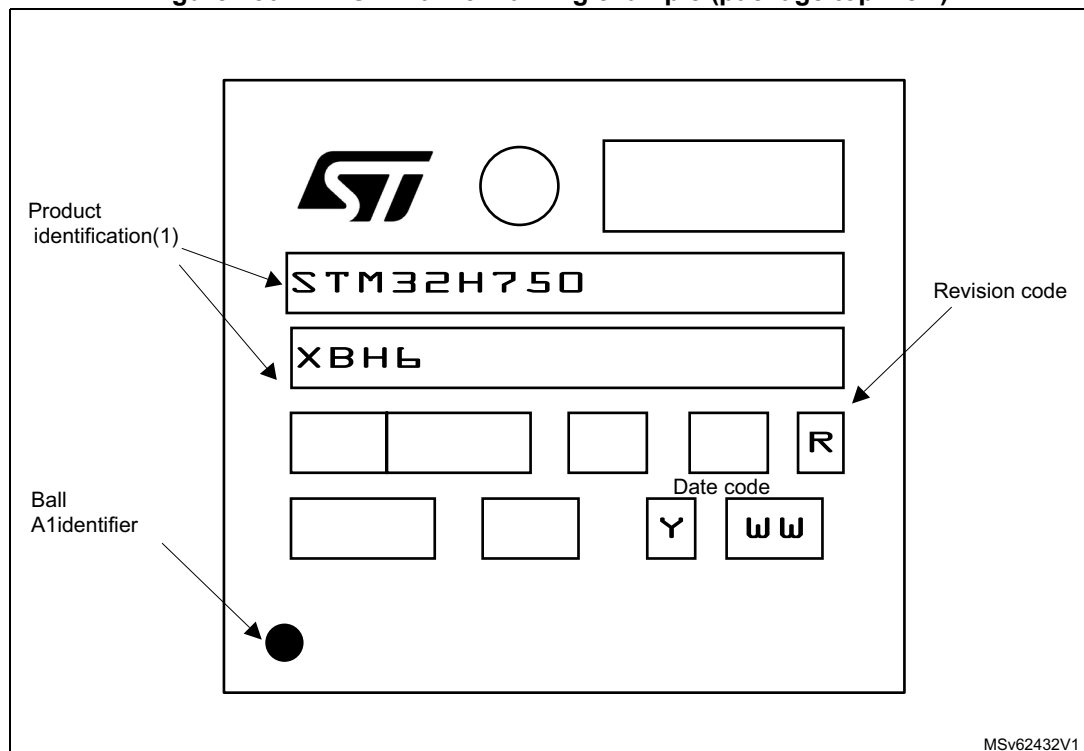

1. Parts marked as “ES”, “E” or accompanied by an Engineering Sample notification letter, are not yet qualified and therefore not approved for use in production. ST is not responsible for any consequences resulting from such use. In no event will ST be liable for the customer using any of these engineering samples in production. ST’s Quality department must be contacted prior to any decision to use these engineering samples to run a qualification activity.

## 8.6 Thermal characteristics

The maximum chip-junction temperature,  $T_J \text{ max}$ , in degrees Celsius, may be calculated using the following equation:

$$T_J \text{ max} = T_A \text{ max} + (P_D \text{ max} \times \Theta_{JA})$$

Where:

- $T_A \text{ max}$  is the maximum ambient temperature in °C,
- $\Theta_{JA}$  is the package junction-to-ambient thermal resistance, in °C/W,
- $P_D \text{ max}$  is the sum of  $P_{INT} \text{ max}$  and  $P_{I/O} \text{ max}$  ( $P_D \text{ max} = P_{INT} \text{ max} + P_{I/O} \text{ max}$ ),
- $P_{INT} \text{ max}$  is the product of  $I_{DD}$  and  $V_{DD}$ , expressed in Watts. This is the maximum chip internal power.

$P_{I/O} \text{ max}$  represents the maximum power dissipation on output pins where:

$$P_{I/O} \text{ max} = \Sigma (V_{OL} \times I_{OL}) + \Sigma ((V_{DD} - V_{OH}) \times I_{OH}),$$

taking into account the actual  $V_{OL} / I_{OL}$  and  $V_{OH} / I_{OH}$  of the I/Os at low and high level in the application.

**Table 222. Thermal characteristics**

Symbol	Definition	Parameter	Value	Unit
$\Theta_{JA}$	Thermal resistance junction-ambient	<b>Thermal resistance junction-ambient</b> LQFP100 - 14 x 14 mm /0.5 mm pitch	45.0	°C/W
		<b>Thermal resistance junction-ambient</b> LQFP144 - 20 x 20 mm /0.5 mm pitch	43.7	
		<b>Thermal resistance junction-ambient</b> LQFP176 - 24 x 24 mm /0.5 mm pitch	43.0	
		<b>Thermal resistance junction-ambient</b> UFBGA176+25 - 10 x 10 mm /0.65 mm pitch	37.4	
		<b>Thermal resistance junction-ambient</b> TFBGA240+25 - 14 x 14 mm / 0.8 mm pitch	36.6	
$\Theta_{JB}$	Thermal resistance junction-board	<b>Thermal resistance junction-ambient</b> LQFP100 - 14 x 14 mm /0.5 mm pitch	36.3	°C/W
		<b>Thermal resistance junction-ambient</b> LQFP144 - 20 x 20 mm /0.5 mm pitch	38.3	
		<b>Thermal resistance junction-ambient</b> LQFP176 - 24 x 24 mm /0.5 mm pitch	43.0	
		<b>Thermal resistance junction-ambient</b> UFBGA176+25 - 10 x 10 mm /0.65 mm pitch	19.3	
		<b>Thermal resistance junction-ambient</b> TFBGA240+25 - 14 x 14 mm / 0.8 mm pitch	24.3	

Table 222. Thermal characteristics

Symbol	Definition	Parameter	Value	Unit
$\Theta_{JC}$	Thermal resistance junction-case	<b>Thermal resistance junction-ambient</b> LQFP100 - 14 x 14 mm /0.5 mm pitch	11.5	°C/W
		<b>Thermal resistance junction-ambient</b> LQFP144 - 20 x 20 mm /0.5 mm pitch	11.3	
		<b>Thermal resistance junction-ambient</b> LQFP176 - 24 x 24 mm /0.5 mm pitch	11.2	
		<b>Thermal resistance junction-ambient</b> UFBGA176+25 - 10 x 10 mm /0.65 mm pitch	23.9	
		<b>Thermal resistance junction-ambient</b> TFBGA240+25 - 14 x 14 mm / 0.8 mm pitch	7.4	

### 8.6.1 Reference document

- JESD51-2 Integrated Circuits Thermal Test Method Environment Conditions - Natural Convection (Still Air). Available from [www.jedec.org](http://www.jedec.org).
- For information on thermal management, refer to application note “Thermal management guidelines for STM32 32-bit Arm Cortex MCUs applications” (AN5036) available from [www.st.com](http://www.st.com).

## 9 Ordering information

Example:	STM32	H	750	X	B	T	6	TR <sup>(1)</sup>
Device family	<div style="display: flex; justify-content: space-between; border-bottom: 1px solid black; padding-bottom: 5px;"> <span>STM32 = Arm-based 32-bit microcontroller</span> <span>H = High performance</span> <span>750 = STM32H750 value line with cryptographic accelerator</span> <span>X = 240 balls</span> <span>B = 128 Kbytes</span> <span>T = LQFP ECOPACK2 K = UFBGA pitch 0.65 mm ECOPACK2 H = TFBGA ECOPACK2</span> <span>6 = -40 to 85 °C</span> <span>TR = tape and reel No character = tray or tube</span> </div>							
Product type								
Device subfamily								
Pin count								
Flash memory size								
Package								
Temperature range								
Packing								

1. The tape and reel packing is not available on all packages.

For a list of available options (speed, package, etc.) or for further information on any aspect of this device, please contact your nearest ST sales office.

## 10 Revision history

**Table 223. Document revision history**

Date	Revision	Changes
21-May-2018	1	Initial release.
29-Jun-2018	2	<p>Changed datasheet status to “production data”.</p> <p>Added description of power-up and power-down phases in <a href="#">Section 3.5.1: Power supply scheme</a>.</p> <p>Updated <a href="#">Table 44: HSI48 oscillator characteristics</a>, <a href="#">Table 45: HSI oscillator characteristics</a> and <a href="#">Table 46: CSI oscillator characteristics</a>.</p> <p>Renamed <a href="#">Table 48</a> into “PLL characteristics (wide VCO frequency range)” and updated note 2.. Added <a href="#">Table 49: PLL characteristics (medium VCO frequency range)</a>. Updated <math>t_{S\_vbat}</math> in <a href="#">Table 92: V<sub>BAT</sub> monitoring characteristics</a>.</p> <p>Updated <a href="#">Table 97: OPAMP characteristics</a>.</p>
05-Apr-2019	3	<p>Changed maximum Arm Core-M7 frequency to 480 MHz.</p> <p><b>Features:</b></p> <ul style="list-style-type: none"> <li>– Changed operational amplifier bandwidth to 7.3 MHz</li> <li>– Updated high-resolution timer to 2.1 ns</li> <li>– Updated low-power consumption feature</li> </ul> <p>Updated voltage scaling in <a href="#">Section 3.5.1: Power supply scheme</a>. Added VOS0 in <a href="#">Section 3.5.3: Voltage regulator</a>.</p> <p>Updated HSE clock in <a href="#">Section 3.7.1: Clock management</a>.</p> <p>Removed ETH_TX_ER from <a href="#">Table 7: STM32H750xB pin/ball definition</a>.</p> <p>Updated <a href="#">Section 6: Electrical characteristics (rev Y)</a>:</p> <ul style="list-style-type: none"> <li>– Added note related to decoupling capacitor tolerance below <a href="#">Figure 11: Power supply scheme</a>.</li> <li>– Added note 2. related to CEXT in <a href="#">Table 23: VCAP operating conditions</a>.</li> <li>– Updated note 2 below <a href="#">Figure 19: Recommended NRST pin protection</a>.</li> <li>– Updated <math>f_{HSI48}</math> in <a href="#">Table 44: HSI48 oscillator characteristics</a>.</li> <li>– Updated <math>t_{stab}</math> in <a href="#">Table 45: HSI oscillator characteristics</a>.</li> <li>– Removed note 2 in <a href="#">Table 49: PLL characteristics (medium VCO frequency range)</a>.</li> <li>– Added <a href="#">Table 60: Output voltage characteristics for PC13, PC14, PC15 and PI8</a>.</li> <li>– Added note related to PC13, PC14, PC15 an PI8 limited frequency in <a href="#">Table 61: Output timing characteristics (HSLV OFF)</a>.</li> <li>– Updated <math>T_{coeff}</math> in <a href="#">Table 89: VREFBUF characteristics</a>.</li> <li>– <a href="#">Table 85: ADC characteristics</a>: updated <math>f_S</math> and added note related to <math>f_S</math> formula; updated <math>t_{CAL}</math>.</li> <li>– Renamed <a href="#">Section 6.3.24</a> into <i>Temperature and VBAT monitoring</i> and content updated.</li> <li>– Updated <math>f_{DFSDMCLK}</math> in <a href="#">Table 98: DFSDM measured timing - 1.62-3.6 V</a>.</li> </ul> <p>Added <a href="#">Section 7: Electrical characteristics (rev V)</a>.</p> <p>Updated paragraph introducing all package marking schematics to add the new sentence “The printed markings may differ depending on the supply chain”. Updated <a href="#">Table 222: Thermal characteristics</a>. Added note related to ECOPACK<sup>®</sup>2 compliance in <a href="#">Section 9: Ordering information</a>.</p>

**Table 223. Document revision history**

Date	Revision	Changes
24-Apr-2019	4	<p>Updated <a href="#">Figure 1: STM32H750xB block diagram</a></p> <p>Updated <a href="#">Table 7: STM32H750xB pin/ball definition</a>.</p> <p>Updated <a href="#">Table 8</a> to <a href="#">Table 18</a> (alternate functions).</p> <p>Updated <a href="#">Table 37: Peripheral current consumption in Run mode</a>.</p> <p>Updated <a href="#">Table 135: Peripheral current consumption in Run mode</a>.</p> <p>Updated <a href="#">Table 182: ADC characteristics</a>.</p> <p>Updated <a href="#">Table 183: Minimum sampling time vs RAIN</a>.</p> <p>Updated <a href="#">Table 184: ADC accuracy</a>.</p> <p>Added device marking examples for all packages in <a href="#">Section 8: Package information</a></p>
22-Nov-2019	5	<p>Added LQFP144 package together with STM32H750ZB part number, and LQFP176 package.</p> <p>In <a href="#">Table 1: STM32H750xB features and peripheral counts</a>, split number of ADC channels into Direct, Fast and Slow channels; and added number of wakeup and tamper pins.</p> <p>Moved LSI from Backup to VDD domain in <a href="#">Figure 11</a> and <a href="#">Figure 64</a>.</p> <p>Updated capacitor value for <math>1.62\text{ V} &lt; V_{DD} &lt; 1.8\text{ V}</math> and <math>FMC\_CLK = 100\text{ MHz}</math> in <a href="#">Section : SDRAM waveforms and timings</a>.</p> <p>Updated <a href="#">Section 6.2</a> and <a href="#">Section 7.2</a> introduction to device mission profile.</p> <p>Power dissipation (<math>P_D</math>) removed from <a href="#">Tables General operating conditions</a> since this parameter is redundant with <math>\Theta_{JA}</math> thermal resistance.</p> <p>Updated maximum frequency for condition “All peripherals disabled and VOS2” <a href="#">Table 128: Typical and maximum current consumption in Run mode, code with data processing running from Flash memory, cache ON, LDO regulator ON</a></p> <p>Updated condition related to <math>f_{rcc\_c\_ck}</math> in <a href="#">Section : On-chip peripheral current consumption</a>.</p> <p>Updated <a href="#">Table 179: QUADSPI characteristics in SDR mode</a>, <a href="#">Figure 35: Quad-SPI timing diagram - DDR mode</a> and <a href="#">Figure 87: Quad-SPI timing diagram - DDR mode</a>.</p> <p>Updated <math>f_{DFSDMCLK}</math> maximum value in <a href="#">Table 98: DFSDM measured timing - 1.62-3.6 V</a> and <a href="#">Table 196: DFSDM measured timing - 1.62-3.6 V</a>.</p> <p>Updated notes <a href="#">4</a> and <a href="#">5</a> in <a href="#">Table 183: Minimum sampling time vs RAIN</a>.</p> <p>Updated <a href="#">Figure 128: TFBGA240+25 package outline</a>.</p> <p>Added note related to the availability of tape and reel packing in <a href="#">Section 9: Ordering information</a>.</p>

**IMPORTANT NOTICE – PLEASE READ CAREFULLY**

STMicroelectronics NV and its subsidiaries (“ST”) reserve the right to make changes, corrections, enhancements, modifications, and improvements to ST products and/or to this document at any time without notice. Purchasers should obtain the latest relevant information on ST products before placing orders. ST products are sold pursuant to ST’s terms and conditions of sale in place at the time of order acknowledgement.

Purchasers are solely responsible for the choice, selection, and use of ST products and ST assumes no liability for application assistance or the design of Purchasers’ products.

No license, express or implied, to any intellectual property right is granted by ST herein.

Resale of ST products with provisions different from the information set forth herein shall void any warranty granted by ST for such product.

ST and the ST logo are trademarks of ST. For additional information about ST trademarks, please refer to [www.st.com/trademarks](http://www.st.com/trademarks). All other product or service names are the property of their respective owners.

Information in this document supersedes and replaces information previously supplied in any prior versions of this document.

© 2019 STMicroelectronics – All rights reserved



Компания «ЭлектроПласт» предлагает заключение долгосрочных отношений при поставках импортных электронных компонентов на взаимовыгодных условиях!

Наши преимущества:

- Оперативные поставки широкого спектра электронных компонентов отечественного и импортного производства напрямую от производителей и с крупнейших мировых складов;
- Поставка более 17-ти миллионов наименований электронных компонентов;
- Поставка сложных, дефицитных, либо снятых с производства позиций;
- Оперативные сроки поставки под заказ (от 5 рабочих дней);
- Экспресс доставка в любую точку России;
- Техническая поддержка проекта, помощь в подборе аналогов, поставка прототипов;
- Система менеджмента качества сертифицирована по Международному стандарту ISO 9001;
- Лицензия ФСБ на осуществление работ с использованием сведений, составляющих государственную тайну;
- Поставка специализированных компонентов (Xilinx, Altera, Analog Devices, Intersil, Interpoint, Microsemi, Aeroflex, Peregrine, Syfer, Eurofarad, Texas Instrument, Miteq, Cobham, E2V, MA-COM, Hittite, Mini-Circuits, General Dynamics и др.);

Помимо этого, одним из направлений компании «ЭлектроПласт» является направление «Источники питания». Мы предлагаем Вам помощь Конструкторского отдела:

- Подбор оптимального решения, техническое обоснование при выборе компонента;
- Подбор аналогов;
- Консультации по применению компонента;
- Поставка образцов и прототипов;
- Техническая поддержка проекта;
- Защита от снятия компонента с производства.



#### Как с нами связаться

**Телефон:** 8 (812) 309 58 32 (многоканальный)

**Факс:** 8 (812) 320-02-42

**Электронная почта:** [org@eplast1.ru](mailto:org@eplast1.ru)

**Адрес:** 198099, г. Санкт-Петербург, ул. Калинина, дом 2, корпус 4, литера А.