

REVISIONS					
REV	ECO	DESCRIPTION	DATE	BY	APPR
A1	-	RELEASE NEW DRAWING	08JUN19	SULLEN	TOMMY
A2	-	UPDATE DRAWING	29JUL19	SULLEN	TOMMY

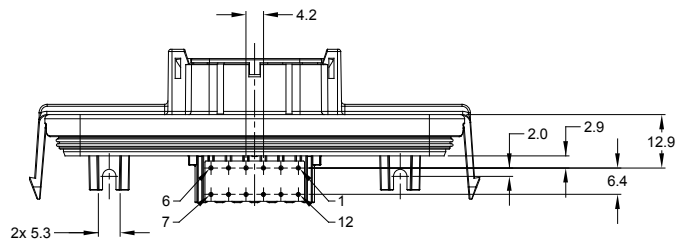
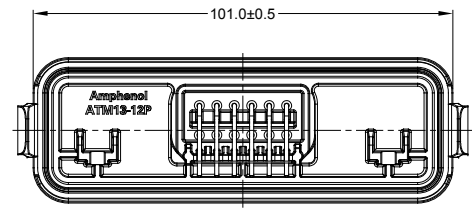
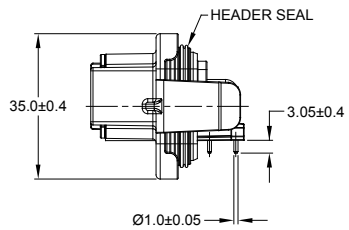
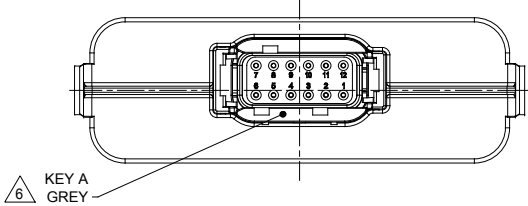
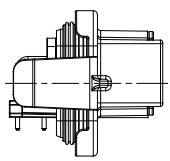
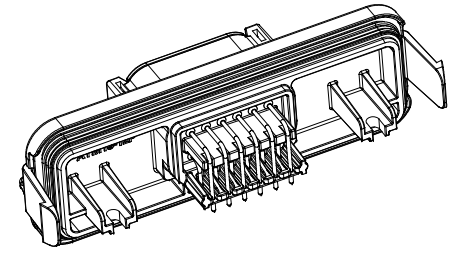
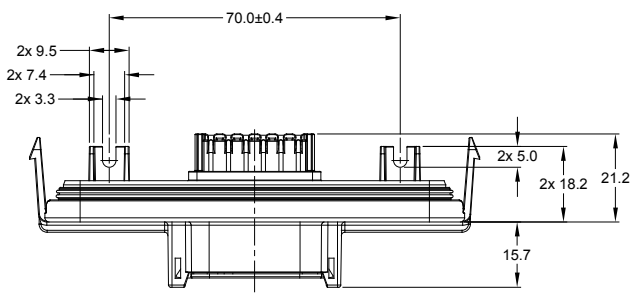

NOTES: UNLESS OTHERWISE SPECIFIED

- MATERIAL:
HOUSING: THERMOPLASTIC, BLACK
SEAL: SILICONE RUBBER
CONTACT: COPPER ALLOY
- MODIFICATIONS: RA PCB MOUNT
- SPECIFICATIONS:
3.1 CURRENT RATING: 7.5 AMPS
3.2 OPERATING TEMPERATURE: -55°C TO +125°C
3.3 DIELECTRIC WITHSTANDING VOLTAGE: LESS THAN 2 MILLIAMPS CURRENT LEAKAGE @ 1500 VOLTS AC
3.4 INSULATION RESISTANCE: 1000 MEGOHMS MIN @ 25°C
3.5 MOISTURE RESISTANCE: IP69K (MATED CONDITION)
3.6 MATING CYCLE DURABILITY: 100 CYCLES
3.7 RoHS COMPLIANT
- MATING PART: ATM06-12SX-*
(X = A,B,C,D KEYS ; * = ALL MODIFICATIONS)
- THIS RECEPTACLE IS USED WITH AIPXE-325X4A-XXXX AND AIPXE-325X4B-XXXX ENCLOSURE (XXXX= ALL MODIFICATIONS)

6 SEE SHEET 2 FOR OTHER KEY ARRANGEMENTS AND COLORS

7 MAXIMUM COMPONENT HEIGHT DEPENDS ON LOCATION DUE TO PART DRAFT AND RIBS.(SEE SHEET 3)

8. ALL DIMENSIONS ARE FOR REFERENCE USE ONLY

SEE SHEET 2		DESCRIPTION		ITEM	
PART NUMBER					
QUANTITY	MATERIALS LIST				
UNLESS OTHERWISE SPECIFIED 1) All dimensions are in metric(mm). 2) Tolerances are as follows: 1 PL DEC ±0.30 Fractions ±1/64 2 PL DEC ±0.15 Angles ±1° 3 PL DEC ±0.08	SIGNATURES	DATE	 Sine Systems - www.amphenol-sine.com 44724 Morley Drive Clinton Township, MI 48036 ARMOR IPX RECEPTACLE ATM HEADER, 12 POSITIONS, SIZE 20 CONTACT		
DRAWN: SULLEN,ZHANG	29JUL19	CHECKED: ORION,LI			29JUL19
ENGINEER:		APPROVAL: TOMMY,XIE			29JUL19
MATERIAL SPECIFICATIONS:	CUSTOMER:				
PROCESS SPECIFICATIONS:	THIS DRAWING IS SUPPLIED FOR INFORMATION ONLY. DESIGN FEATURES, SPECIFICATIONS AND PERFORMANCE DATA SHOWN HEREON ARE THE PROPERTY OF THE AMPHENOL CORPORATION. NO RIGHTS OF REPRODUCTION ARE IMPLIED. ALL DIMENSIONS ARE SUBJECT TO NORMAL MANUFACTURING VARIATIONS.		SIZE	REVISION	
NEXT ASSY:	SCALE: NONE		B C-	ATM13-12PX-XXXX A2	
			SHEET 1	OF 3	

TITLE: ARMOR IPX RECEPTACLE ATM HDR 12 POSITIONS SIZE 20 CONTACT DWG NO: ATM13-12PX-XXXX REV: A2 SH: 1 OF: 3

REVISIONS					
REV	ECO	DESCRIPTION	DATE	BY	APPR
A1	-	RELEASE NEW DRAWING	08JUN19	SULLEN	TOMMY
A2	-	UPDATE DRAWING	29JUL19	SULLEN	TOMMY

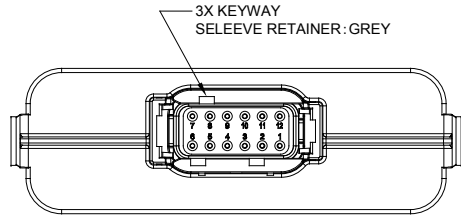

KEY A

ATM13-12PA-XXXX VARIANTS		
CONTACT PLATING	PART NUMBER	REFERENCE
GOLD	ATM13-12PA-GR01	DTM13-12PA-GR01
TIN	ATM13-12PA-R008	DTM13-12PA-R008

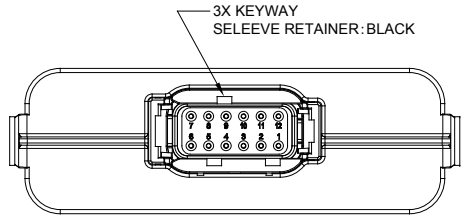

KEY B

ATM13-12PB-XXXX VARIANTS		
CONTACT PLATING	PART NUMBER	REFERENCE
GOLD	ATM13-12PB-GR01	DTM13-12PB-GR01
TIN	ATM13-12PB-R008	DTM13-12PB-R008

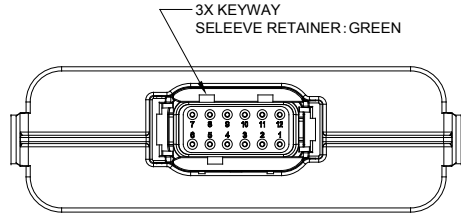

KEY C

ATM13-12PC-XXXX VARIANTS		
CONTACT PLATING	PART NUMBER	REFERENCE
GOLD	ATM13-12PC-GR01	DTM13-12PC-GR01
TIN	ATM13-12PC-R008	DTM13-12PC-R008

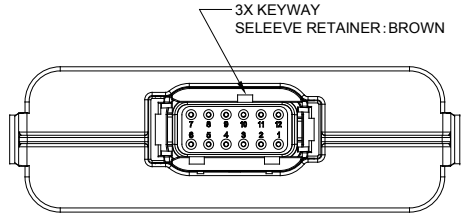

KEY D

ATM13-12PD-XXXX VARIANTS		
CONTACT PLATING	PART NUMBER	REFERENCE
GOLD	ATM13-12PD-GR01	DTM13-12PD-GR01
TIN	ATM13-12PD-R008	DTM13-12PD-R008

ATM13-12PX-XXXX		DESCRIPTION		ITEM
PART NUMBER				
MATERIALS LIST				
QUANTITY UNLESS OTHERWISE SPECIFIED 1) All dimensions are in metric (mm). 2) Tolerances are as follows: 1 PL DEC ±0.30 Fractions ±1/64 2 PL DEC ±0.15 Angles ±1° 3 PL DEC ±0.08 3) Note reference =	SIGNATURES		DATE	
	DRAWN: SULLEN,ZHANG		29JUL19	
MATERIAL SPECIFICATIONS:	CHECKED: ORION,LI		29JUL19	
	ENGINEER:			
PROCESS SPECIFICATIONS:	APPROVAL: TOMMY,XIE		29JUL19	
	CUSTOMER:			
NEXT ASSY:	THIS DRAWING IS SUPPLIED FOR INFORMATION ONLY. DESIGN FEATURES, SPECIFICATIONS AND PERFORMANCE DATA SHOWN HEREON ARE THE PROPERTY OF THE AMPHENOL CORPORATION. NO RIGHTS OF REPRODUCTION ARE IMPLIED. ALL DIMENSIONS ARE SUBJECT TO NORMAL MANUFACTURING VARIATIONS.			
SIZE B TYPE C- SCALE NONE		DWG NO: ATM13-12PX-XXXX REVISION A2		SHEET 2 OF 3

TITLE: ARMOR IPX RECEPTACLE ATM HEADER, 12 POSITIONS, SIZE 20 CONTACT
DWG NO.: ATM13-12PX-XXXX
REV: A2
SH: 2
OF: 3

CIRCUIT BOARD HOLE LOCATIONS
AND KEEP CLEAR AREAS FOR
ATM13-12PX-R008
ATM13-12PX-GR01
ALL DIMENSIONS REFERENCE
TOP VIEW

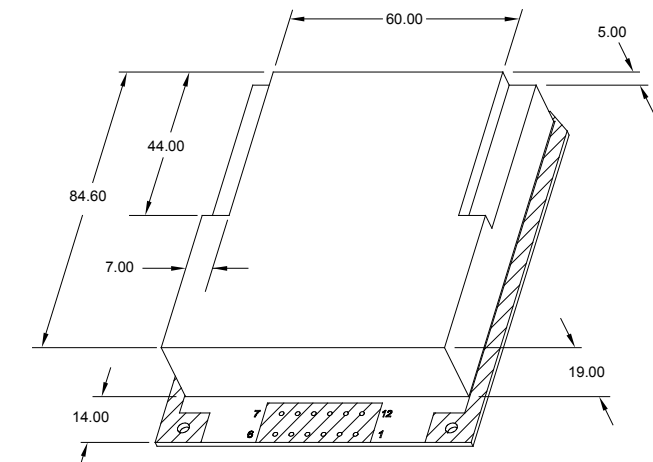
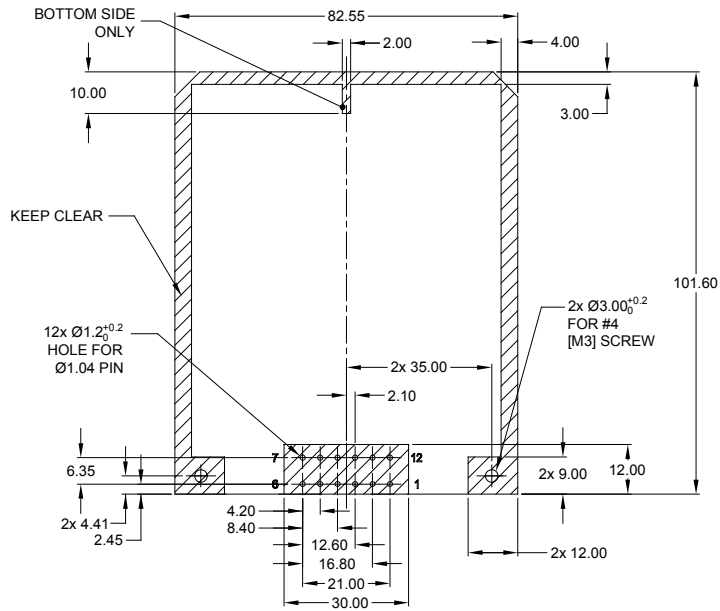

THREE DIMENSIONAL SPACE LIMIT
APPROXIMATE INTERNAL SPACE
FOR COMPONENT SPACE LAYOUT
MAX. COMPONENT HEIGHT UNDER BOARD 2.00 mm.

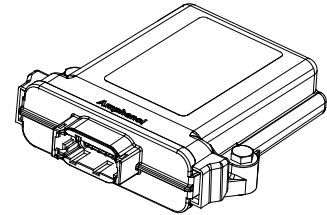

3D VIEW
AIPXE-325X4A-XXXX AND
AIPXE-325X4B-XXXX ENCLOSURE AND
MOUNTING HARDWARE SHOWN FOR REFERENCE

REVISIONS					
REV	ECO	DESCRIPTION	DATE	BY	APPR
A1	-	RELEASE NEW DRAWING	08JUN19	SULLEN	TOMMY
A2	-	UPDATE DRAWING	29JUL19	SULLEN	TOMMY

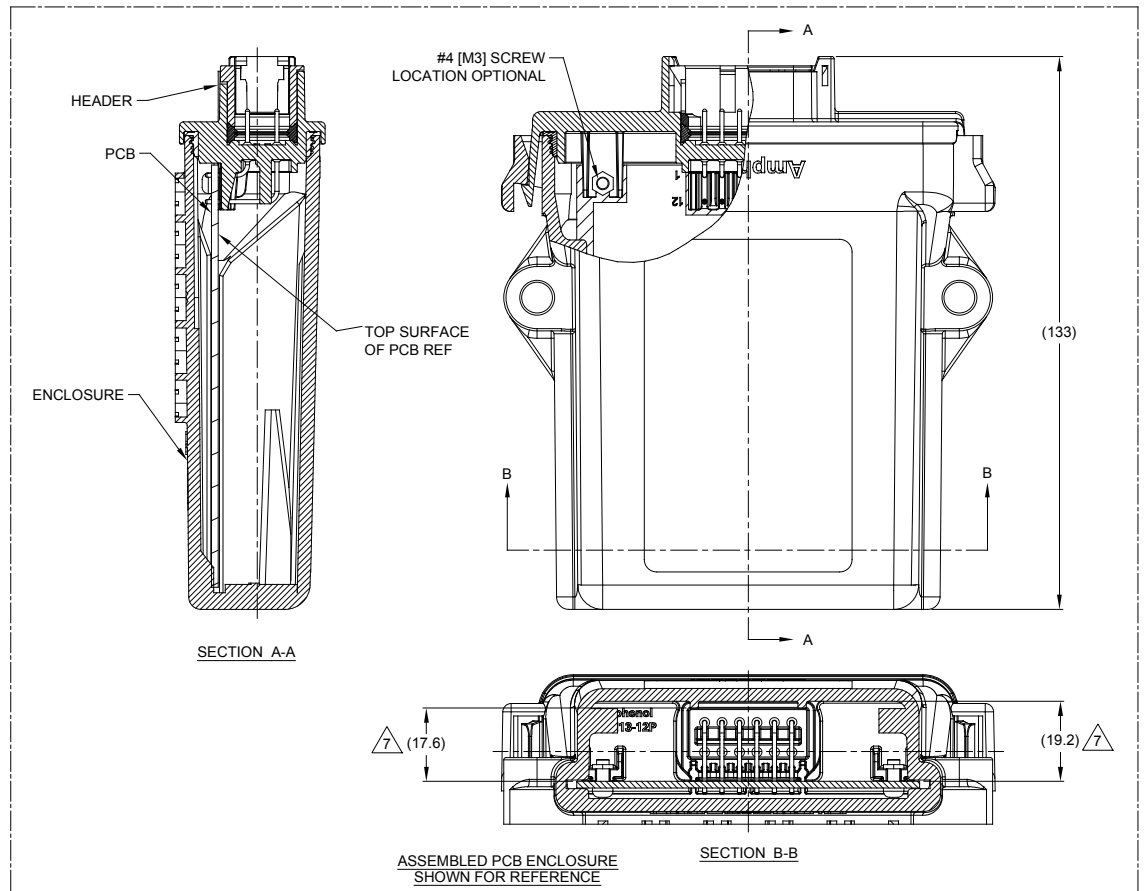

SEE SHEET 2		DESCRIPTION		ITEM
QUANTITY	PART NUMBER	MATERIALS LIST		
UNLESS OTHERWISE SPECIFIED		SIGNATURES	DATE	
1) All dimensions are in metric (mm).		DRAWN: SULLEN,ZHANG	29JUL19	
2) Tolerances are as follows:		CHECKED: ORION,LI	29JUL19	
1 PL DEC ±0.30 Fractions ±1/64		ENGINEER:		
2 PL DEC ±0.15 Angles ±1°		APPROVAL: TOMMY,XIE	29JUL19	
3) Note reference = Δ		CUSTOMER:		
MATERIAL SPECIFICATIONS:		THIS DRAWING IS SUPPLIED FOR INFORMATION ONLY. DESIGN FEATURES, SPECIFICATIONS AND PERFORMANCE DATA SHOWN HEREON ARE THE PROPERTY OF THE AMPHENOL CORPORATION. NO RIGHTS OF REPRODUCTION ARE IMPLIED. ALL DIMENSIONS ARE SUBJECT TO NORMAL MANUFACTURING VARIATIONS.		
PROCESS SPECIFICATIONS:		SINE SYSTEMS - www.amphenol-sine.com 44724 Morley Drive Clinton Township, MI 48036		
NEXT ASSY:		ARMOR IPX RECEPTACLE ATM HEADER, 12 POSITIONS, SIZE 20 CONTACT		
SIZE	TYPE	DWG NO:	REVISION	
B	C-	ATM13-12PX-XXXX	A2	
SCALE	NONE	SHEET	3	OF 3

TITLE: ARMOR IPX RECEPTACLE ATM HDR 12 POSITIONS SIZE 20 CONTACT
DWG NO: ATM13-12PX-XXXX
REV: A2
SH: 3
OF: 3



Компания «ЭлектроПласт» предлагает заключение долгосрочных отношений при поставках импортных электронных компонентов на взаимовыгодных условиях!

Наши преимущества:

- Оперативные поставки широкого спектра электронных компонентов отечественного и импортного производства напрямую от производителей и с крупнейших мировых складов;
- Поставка более 17-ти миллионов наименований электронных компонентов;
- Поставка сложных, дефицитных, либо снятых с производства позиций;
- Оперативные сроки поставки под заказ (от 5 рабочих дней);
- Экспресс доставка в любую точку России;
- Техническая поддержка проекта, помощь в подборе аналогов, поставка прототипов;
- Система менеджмента качества сертифицирована по Международному стандарту ISO 9001;
- Лицензия ФСБ на осуществление работ с использованием сведений, составляющих государственную тайну;
- Поставка специализированных компонентов (Xilinx, Altera, Analog Devices, Intersil, Interpoint, Microsemi, Aeroflex, Peregrine, Syfer, Eurofarad, Texas Instrument, Miteq, Cobham, E2V, MA-COM, Hittite, Mini-Circuits, General Dynamics и др.);

Помимо этого, одним из направлений компании «ЭлектроПласт» является направление «Источники питания». Мы предлагаем Вам помощь Конструкторского отдела:

- Подбор оптимального решения, техническое обоснование при выборе компонента;
- Подбор аналогов;
- Консультации по применению компонента;
- Поставка образцов и прототипов;
- Техническая поддержка проекта;
- Защита от снятия компонента с производства.



Как с нами связаться

Телефон: 8 (812) 309 58 32 (многоканальный)

Факс: 8 (812) 320-02-42

Электронная почта: org@eplast1.ru

Адрес: 198099, г. Санкт-Петербург, ул. Калинина, дом 2, корпус 4, литера А.