

### DESCRIPTION

The EVM3805-QB-01A is used for demonstrating the performance of MPS's MPM3805 a low voltage high switching frequency step-down switcher with built-in power MOSFETs and power inductor. MPM3805 provides up to 0.6A highly efficient output with constant-on-time control for fast loop response.

High power efficiency over a wide load range is achieved by scaling down the switching frequency at light load to reduce the switching related loss by constant on time control. Short circuit and thermal shutdown provides reliable, fault-tolerant operation.

MPM3805 is available in QFN 3.0x2.5x0.9mm package.

### ELECTRICAL SPECIFICATION

Parameter	Symbol	Value	Units
Input Voltage	$V_{IN}$	2.5– 6	V
Output Voltage	$V_{OUT}$	1.2	V
Output Current	$I_{OUT}$	0.6	A

### FEATURES

- Wide 2.5V to 6V Operating Input Range
- Fixed and Adjustable output from 0.6V
- 3mm x 2.5mm x 0.9mm QFN Package
- Total Solution Size 6mm x 3.8mm
- Up to 0.6A Output Current
- 100% Duty Cycle in Dropout
- Ultra Low IQ: 17 $\mu$ A
- EN and Power Good for Power Sequencing
- Cycle-by-Cycle Over-Current Protection
- Short Circuit Protection with Hiccup Mode
- Adjustable Output Only Needs 4 External Components - 2 Ceramic Capacitors and FB Divider Resistors
- Fixed Output only Needs Input and Output Capacitors

### APPLICATIONS

- Low Voltage I/O System Power
- LDO Replacement
- Power for Portable Products
- Storage (SSD/HDD)
- Space-limited Applications

All MPS parts are lead-free and adhere to the RoHS directive. For MPS green status, please visit MPS website under Quality Assurance. "MPS" and "The Future of Analog IC Technology", are Registered Trademarks of Monolithic Power Systems, Inc.

ADAM (Analog Digital Adaptive Modulation), AAM (....) are Trademarks of Monolithic Power Systems, Inc.

## EVM3805-QB-01A EVALUATION BOARD



Board Number	MPS IC Number
EVM3805-QB-01A	MPM3805GQB

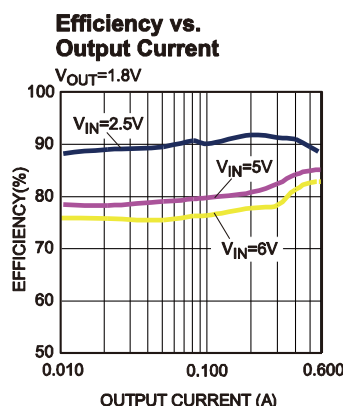

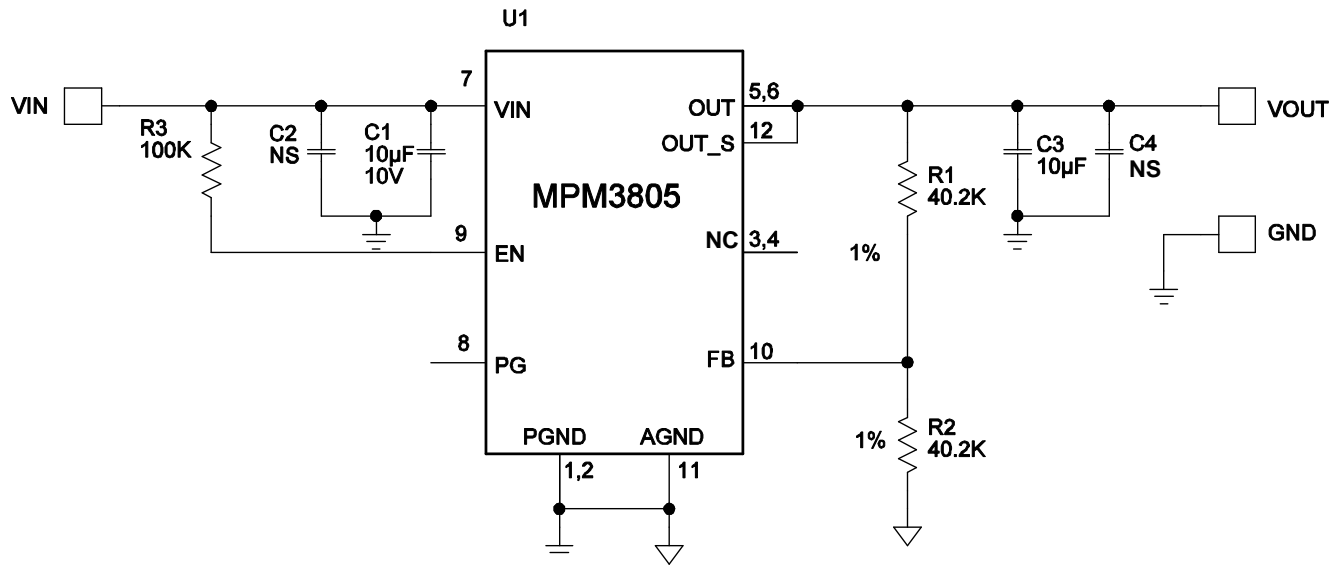
**EVALUATION BOARD SCHEMATIC**

**EVM3805-QB-01A BILL OF MATERIALS**

Qty	RefDes	Value	Description	Package	Manufacturer	Manufacturer P/N
2	C1, C3	10µF	Ceramic Cap., 10V, X5R	SM0805	TDK	C2012X5R1A106K
0	C2, C4	NS				
1	R1	40.2k	Film Res., 1%	SM0603	Any	
1	R2	40.2k	Film Res., 1%	SM0603	Any	
1	R3	100kΩ	Film Res., 5%	SM0603	Yageo	RC0603FR-07100KL
1	U1		COT Buck	QFN3.0*2.5	MPS	MPM3805GQB

## PRINTED CIRCUIT BOARD LAYER

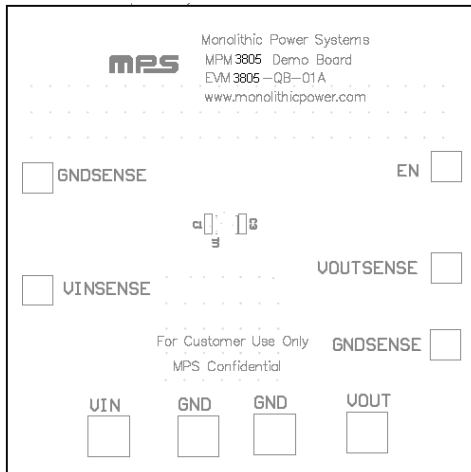

Figure 1: Top Silk Layer

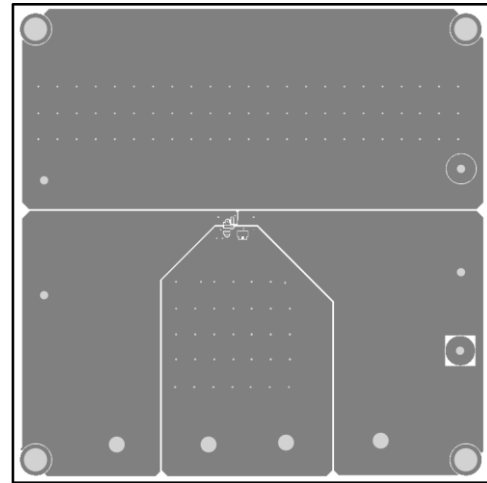

Figure 2: Top Layer

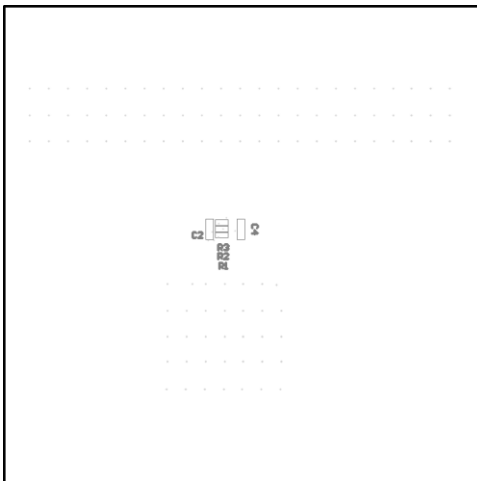

Figure 3: Bottom Silk Layer

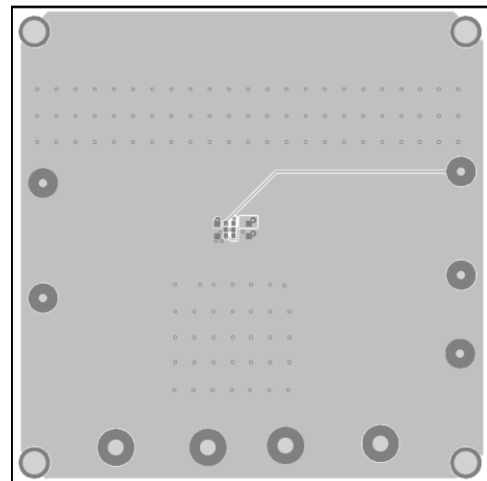

Figure 4: Bottom Layer

## QUICK START GUIDE (ADJUSTABLE OUTPUT)

The output voltage of this board is set externally which can be regulated as low as 0.6V by operating from +2.5V to +6V input as the figure 5. The default output voltage of this board is set to 1.2V.

1. Connect the positive and negative terminals of the load to the VOUT and GND pins, respectively.
2. Preset the power supply output between 2.5V and 6V, and then turn off the power supply.
3. Connect the positive and negative terminals of the power supply output to the VIN and GND pins, respectively.
4. Turn the power supply on. The board will automatically start up.
5. The Output Voltage  $V_{OUT}$  can be changed by varying R2. Choose R1 to be around 40kΩ to 80kΩ. R2 is then given by:

$$R2 = \frac{R1}{\frac{V_{out}}{0.6} - 1}$$

Example: For  $V_{OUT}= 1V$ ,  $R1=40k\Omega$ ,  $R2=60k\Omega$ .

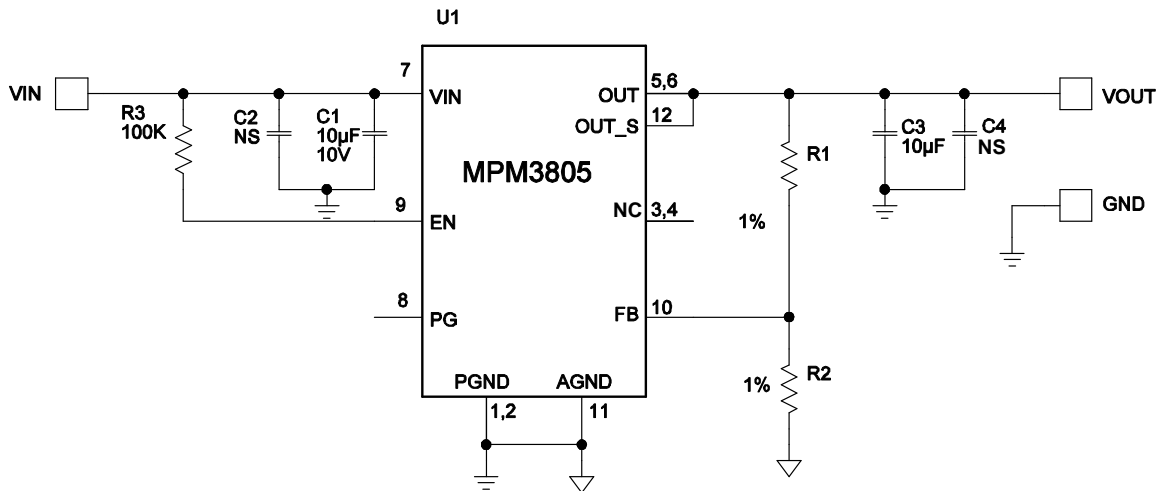

**Figure 5—Adjustable Version**

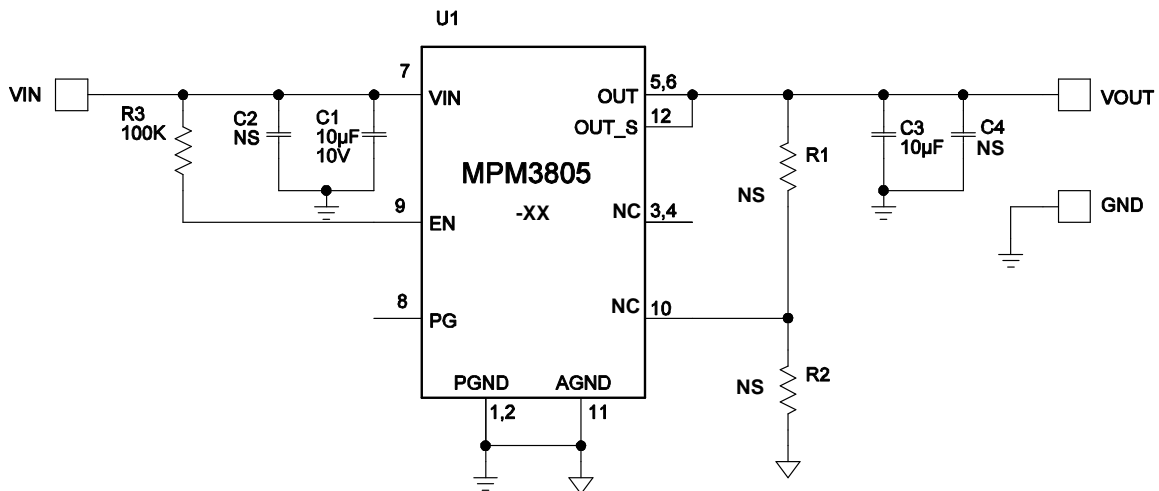

**Figure 6—Fixed Version**

## QUICK START GUIDE (MODIFICATION FOR FIXED OUTPUT)

For modifying the EVM3805QB-01A to accommodate a fixed output voltage version of the MPM3805GQB-12(-18,-25,-33) as the figure 6:

1. Carefully remove the IC (U1) and replace it with the corresponding fixed output version of the MPM3805GQB-xx chip.
2. Remove both R1 and R2.
3. Connect the positive and negative terminals of the load to the VOUT and GND pins, respectively.
4. Preset the power supply output between 2.5V and 6V, and then turn off the power supply.
5. Connect the positive and negative terminals of the power supply output to the VIN and GND pins, respectively.
6. Turn the power supply on. The board will automatically start up. Fixed output versions are shown in Table 1.

**Table 1. Fixed output version information**

Part Number	Fixed Vo (V)
MPM3805GQB-12	1.2
MPM3805GQB-18	1.8
MPM3805GQB-25	2.5
MPM3805GQB-33	3.3

## LAYOUT RECOMMENDATION OF MPM3805

Proper layout of the switching power supplies is very important, and sometimes critical to make it work properly. Especially, for the high switching converter, if the layout is not carefully done, the regulator could show poor line or load regulation, stability issues.

**NOTICE:** The information in this document is subject to change without notice. Users should warrant and guarantee that third party Intellectual Property rights are not infringed upon when integrating MPS products into any application. MPS will not assume any legal responsibility for any said applications.



Компания «ЭлектроПласт» предлагает заключение долгосрочных отношений при поставках импортных электронных компонентов на взаимовыгодных условиях!

Наши преимущества:

- Оперативные поставки широкого спектра электронных компонентов отечественного и импортного производства напрямую от производителей и с крупнейших мировых складов;
- Поставка более 17-ти миллионов наименований электронных компонентов;
- Поставка сложных, дефицитных, либо снятых с производства позиций;
- Оперативные сроки поставки под заказ (от 5 рабочих дней);
- Экспресс доставка в любую точку России;
- Техническая поддержка проекта, помощь в подборе аналогов, поставка прототипов;
- Система менеджмента качества сертифицирована по Международному стандарту ISO 9001;
- Лицензия ФСБ на осуществление работ с использованием сведений, составляющих государственную тайну;
- Поставка специализированных компонентов (Xilinx, Altera, Analog Devices, Intersil, Interpoint, Microsemi, Aeroflex, Peregrine, Syfer, Eurofarad, Texas Instrument, Miteq, Cobham, E2V, MA-COM, Hittite, Mini-Circuits, General Dynamics и др.);

Помимо этого, одним из направлений компании «ЭлектроПласт» является направление «Источники питания». Мы предлагаем Вам помощь Конструкторского отдела:

- Подбор оптимального решения, техническое обоснование при выборе компонента;
- Подбор аналогов;
- Консультации по применению компонента;
- Поставка образцов и прототипов;
- Техническая поддержка проекта;
- Защита от снятия компонента с производства.



#### Как с нами связаться

**Телефон:** 8 (812) 309 58 32 (многоканальный)

**Факс:** 8 (812) 320-02-42

**Электронная почта:** [org@eplast1.ru](mailto:org@eplast1.ru)

**Адрес:** 198099, г. Санкт-Петербург, ул. Калинина, дом 2, корпус 4, литера А.