



Test Procedure for the CCR230PS3GEVK Evaluation Kit

1 Devices under test

- Driver board CCR230PS3AGEVB



- LED board CCR230PS3BGEVB

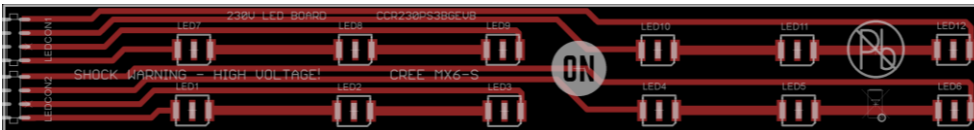



2 Basic functionality tests

Basic functionality tests described below demonstrate fundamental working operation of driver and LED boards. No special skills are needed, however **test person must be careful of hazardous voltage presented in test circuit.**

2.1 Basic operation test

Test equipment required:

- Galvanic-isolated AC power supply, output voltage adjustable from 200 - 240 VAC
- RMS multi-meter (AC voltage range up to 250V or more, AC current range up to 200mA or more)

Test sequence:

1. Turn ON AC power supply (not connected to the driver board), set its output voltage to **230 VAC** using multi-meter, turn it OFF afterwards.
2. Connect LED board to driver board.
3. Connect AC power supply output to the driver board input, so that AC input current is measured by multi-meter.

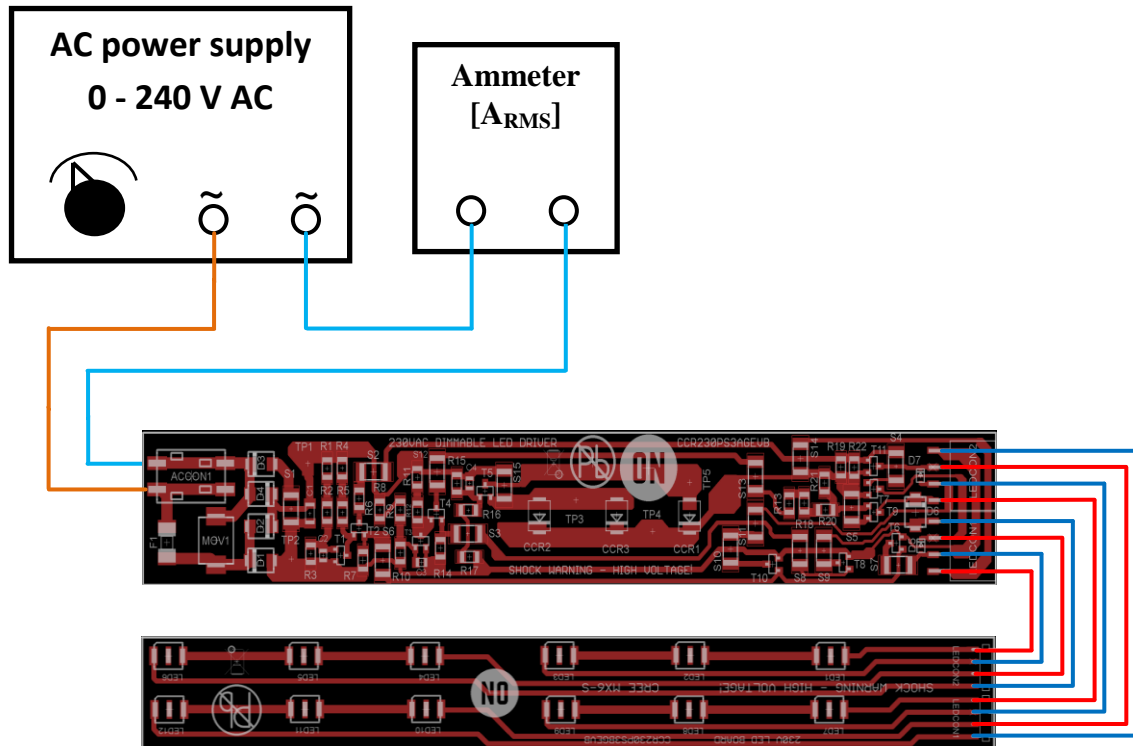

4. Turn AC power supply ON again.



5. All LEDs on LED board shall illuminate, no flicker should be noticeable, AC input current should be around 65 mA. Note: Intensity of light emitted by LEDs is relatively high, use appropriate eye protection during testing and/or avoid looking directly into the lights.
6. Vary AC input voltage in a range from 200 up to 240 VAC, no light interruptions or flicker should be observed, though certain small brightness variation should be noticed—this is normal.

3 Advanced functionality tests

Advanced functionality tests described below verify operation of the driver and the LED boards in more detail than basic functionality tests. Certain test personnel skills level are expected. **Test person must be very careful of hazardous voltage presented in test circuit.**

3.1 Switching levels test

This test can be used for verification of driver board correct operation. Particular switching voltage levels as well as current limitation levels are measured.

Test equipment required:

- Galvanic-isolated AC power supply, output voltage adjustable over range from 60 - 240 VAC
- RMS multi-meter (AC voltage range up to 250V or more)
- Oscilloscope with two or more channels
- Two differential voltage probes with maximum common and differential voltage 400V or more (because of isolated AC power supply usage and common ground reference point during test, one differential probe may be replaced by 1/10 or 1/100 oscilloscope probe, however differential probes are highly recommended)
- One current probe (capable of measuring of DC+AC current of 200mA or more)

Test sequence:

1. Turn ON AC power supply (not connected to the driver board), set its output voltage to **65 VAC** using multi-meter, **turn it OFF afterwards.**
2. Connect LED board to driver board.
3. Connect AC power supply output to the driver board.
4. Connect one differential probe to the driver board AC input, this will be used also as a oscilloscope trigger source (expected maximal signal level is up to ± 340 V, 680 V peak-to-peak).
5. Clamp current probe around one of the AC input wires connected to the driver board, do not forget eventual 50 Ω termination (depending on used current probe type, expected current level is up to 200 mA peak-to-peak).



- Connect second differential probe between anode of LED string #1 and cathode of LED string #4 (expected voltage level is up to 240 V).

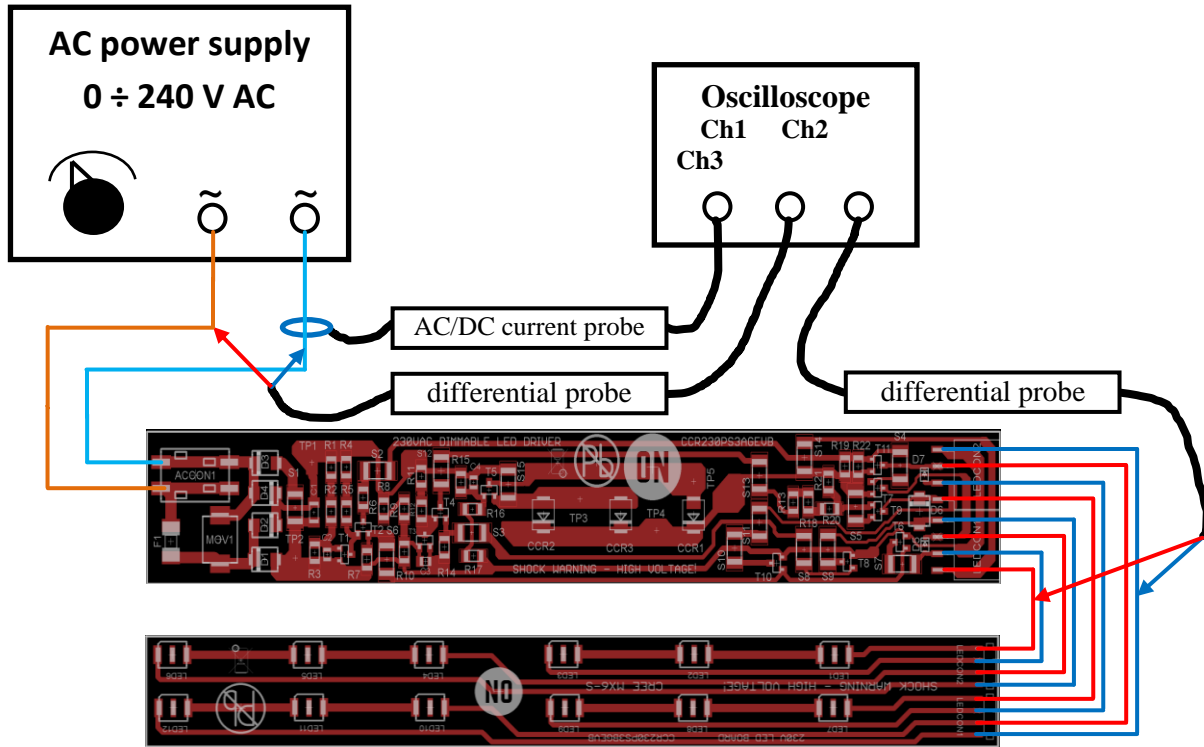

- Set all used oscilloscope channels according to expected signal levels.



8. Turn AC power supply ON again (65 VAC).
9. Inspect input current waveform: apparent, almost stable input current level around 50 mA should be noticed. Input current transitions should be located near to the point where driver board AC input voltage crosses 56V (one LED string forward voltage, as all four LED strings are connected in parallel).
10. Inspect voltage waveform measured by differential probe connected according to Step 6: apparent, almost stable voltage level around 56V should be noticeable. Transition between this voltage and zero should follow driver board AC input voltage (both polarities).

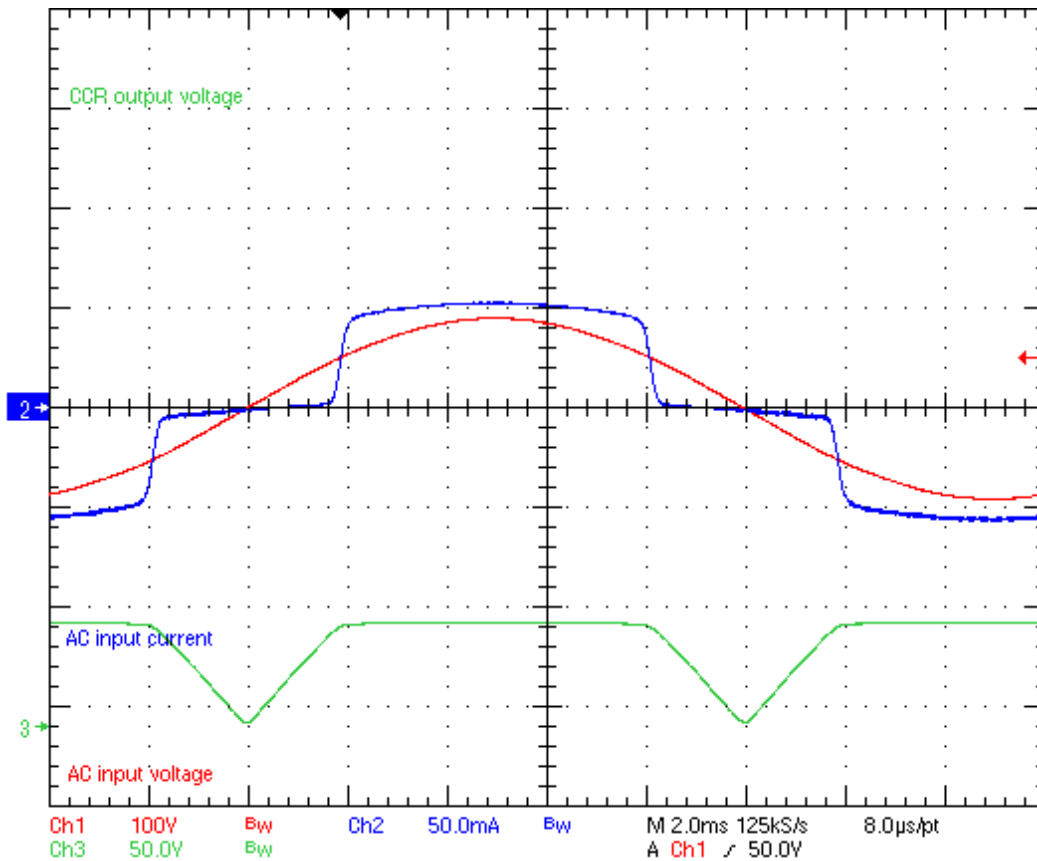



11. Increase AC input voltage to **150 VAC**.
12. Inspect input current waveform: two different current levels around 50 mA and 80 mA should be noticeable. Transition between those two current levels should be located near to the point where driver board AC input voltage crosses 186 V.
13. Inspect voltage waveform measured by differential probe connected according to Step 6: two apparently different, almost stable voltage levels around 56 V and 112 V should be noticeable. Transition between both voltage levels should be located near to the point where driver board AC input voltage crosses 110 V (both polarities). In fact, lower voltage level indicates the time interval during which all four LED strings are connected in parallel, and the higher voltage level indicates the time interval when the LEDs are configured as two long parallel strings (each long parallel string comprised of two series 56 V strings).

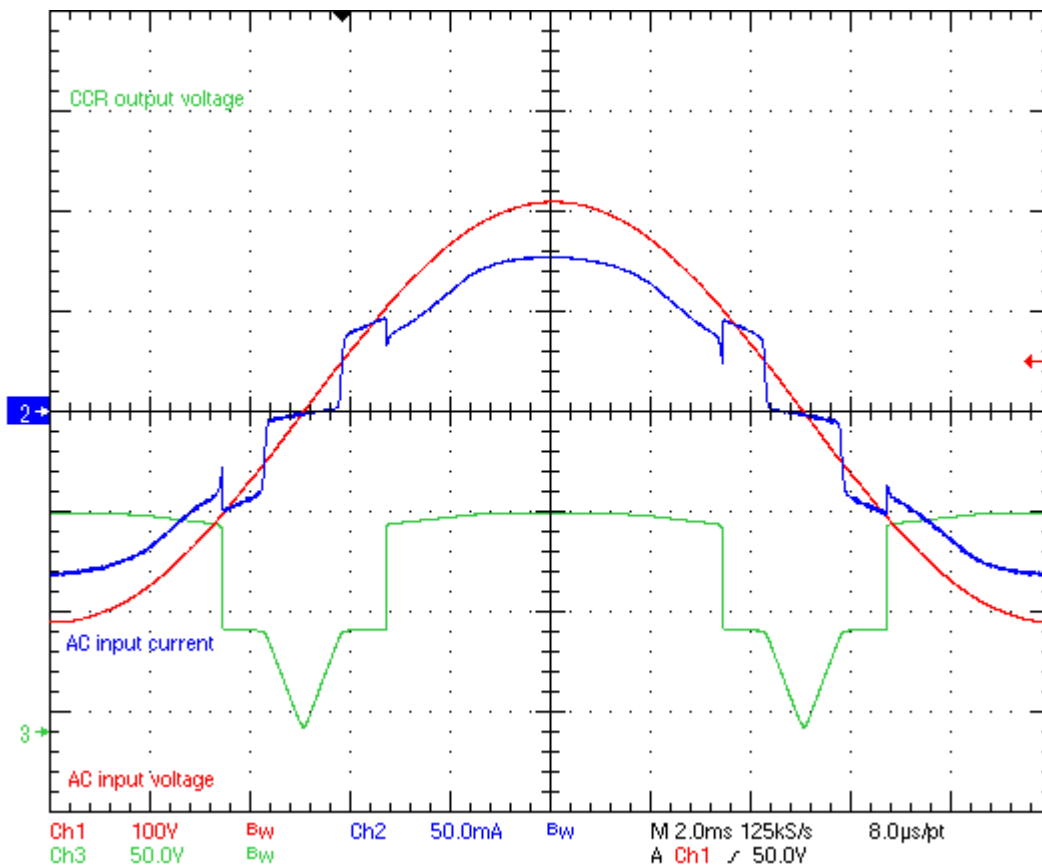



14. Increase AC input voltage to **230 VAC**.
15. Inspect input current waveform: two different current levels around 50 mA and 80 mA should be noticeable. Transition between those two current levels should be located near to the point where driver board AC input voltage crosses 186 V.
16. Inspect voltage waveform measured by differential probe connected according point 6.: three apparently different, almost stable voltage levels around 56 V, 112 V and 224 V should be noticeable. Transition between 56 V and 112 V voltage levels should be located near to the point where driver board AC input voltage crosses 110V, transition between 112 V and 224 V should be located near to the point where driver board AC input voltage crosses 230 V (both polarities of AC input voltage). In fact, short 56 V voltage level indicates the time interval during which all four LED strings are connected in parallel, slightly longer 112 V voltage level indicates the time interval when LEDs are configured as two longer strings (formed by series connection of two 56 V strings) and finally, the longest 224 V voltage level indicates the time interval when all four LED strings are connected in series.

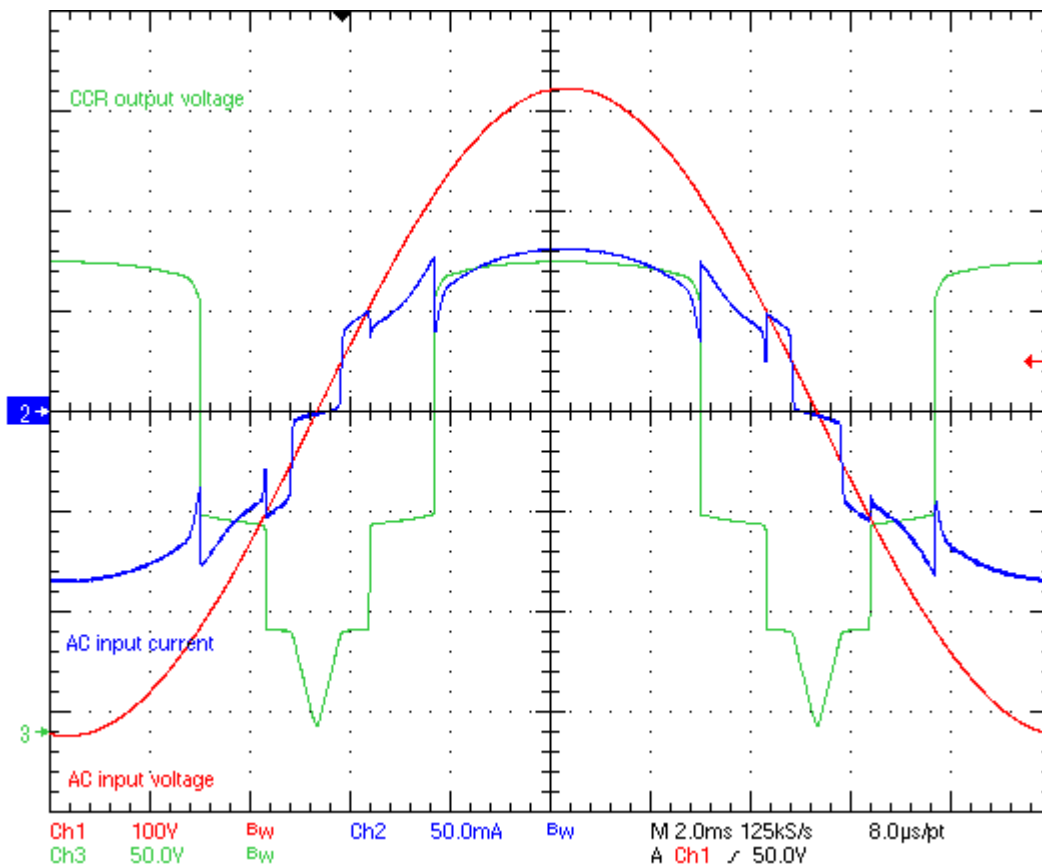

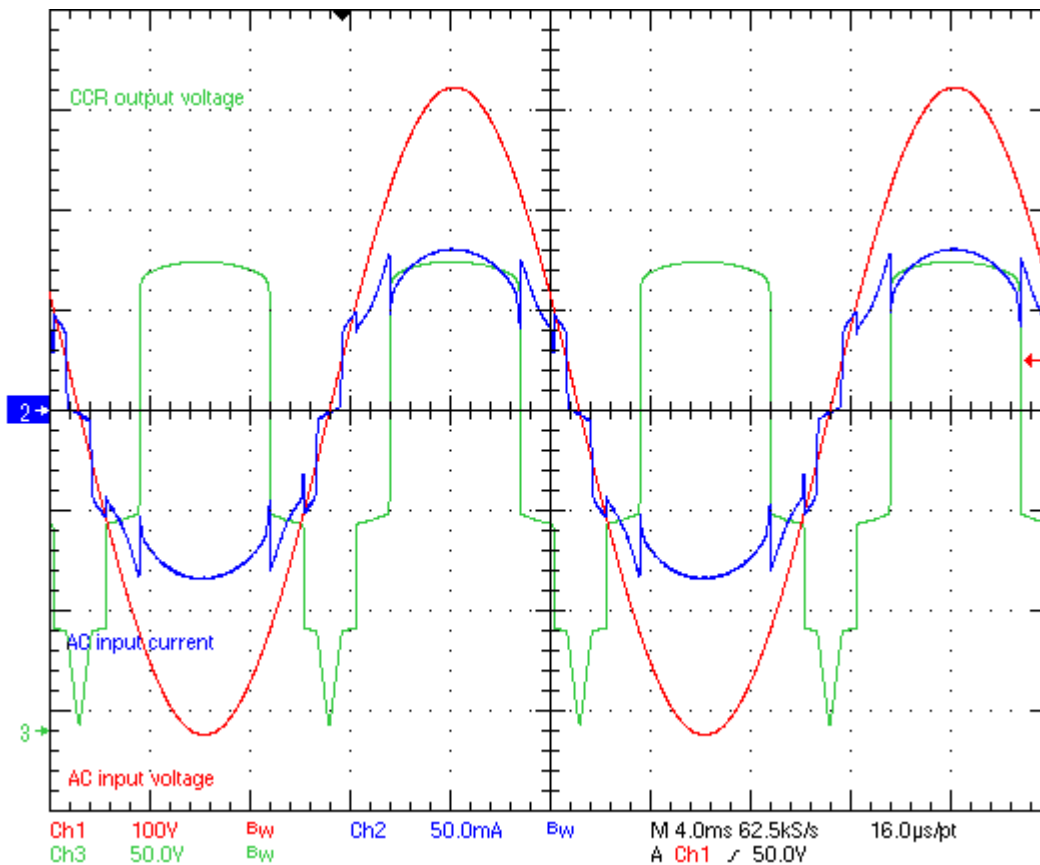

3.2 Efficiency measurement

This test evaluates driver board efficiency, and if test equipment is available, checks power factor and THD.

Test equipment required:

- Galvanic-isolated AC power supply, output voltage adjustable over range from 200 - 240 VAC
- AC power analyzer (AC voltage range up to 250VAC or more, AC current range up to 100mA or more). Note: If no AC power analyzer is available it can be replaced by combination of two RMS multi-meters (AC voltage range up to 250 V or more, AC current range up to 100mA or more). Input power can be calculated by multiplication of AC input voltage and AC input current, however it provides **apparent input power figures instead of real input power**. Additionally, neither power factor nor AC input current THD can be measured using 2 multi-meters method
- RMS voltmeter (DC voltage range up to 300 V or more) – used for driver board output voltage measurement. If available, using a second would be preferable, so that voltages of multiple LED strings can be measured simultaneously, though this is not required.



- RMS ammeter (DC current range up to 100 mA or more) – used for driver board output current measurement. For the same reasons as above, if additional ammeters are available, they will allow for simultaneous measurements and faster testing.

Test sequence:

1. Turn ON AC power supply (not connected to the driver board), set its output voltage to **230 VAC** using multi-meter, turn it OFF afterwards.
2. Connect LED board to driver board.
3. Connect AC power supply output to the AC power analyzer input.
4. Connect AC power analyzer input to the driver board AC input.
5. Connect LED board to driver board using wires so that LED string #1 current and voltage can be measured using RMS voltmeter and RMS ammeter. If available, the tester may connect additional RMS voltmeters and ammeters to measure other LED string voltages simultaneously.

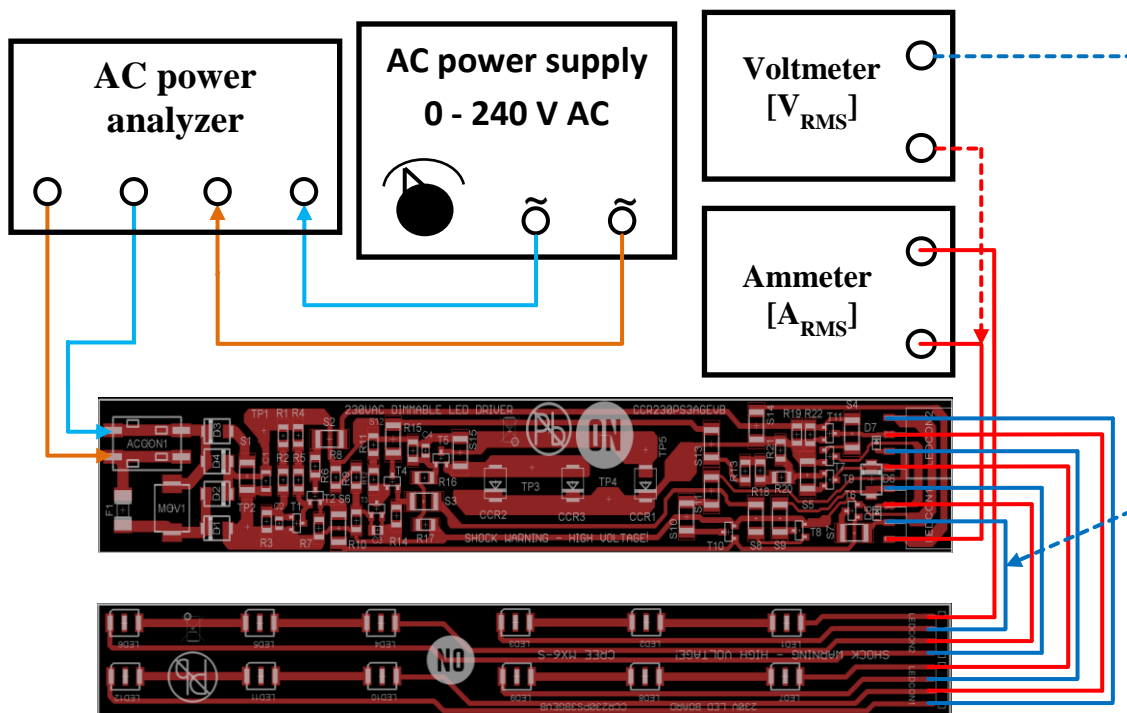

6. Turn AC power supply ON again. Allow circuit to run for 1 minute to stabilize for thermal settling before taking measurements.
7. Write down **real input power** value measured by AC power analyzer, check also power factor and THD parameter in case of interest (expected PF is ~0.98 and expected THD is ~16-18%).

8. Write down LED string #1 RMS voltage and RMS current. Calculate output power multiplying those values. If additional LED voltage/current measurements were taken, calculate these powers too and skip the appropriate steps below.
9. Turn AC power supply OFF.
10. Rearrange LED board connection to driver board so that LED string #2 current and voltage can be measured.

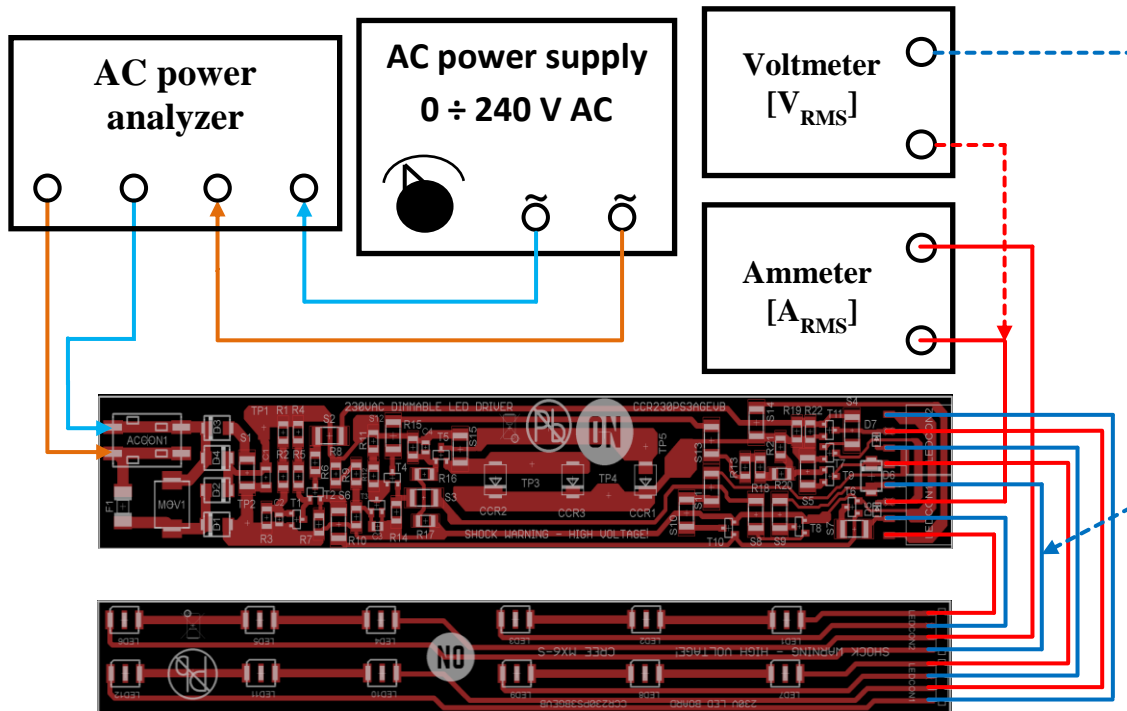

11. Turn AC power supply ON again. Allow circuit to run for 1 minute to stabilize for thermal settling before taking measurements.
12. Check that AC input voltage is still 230VAC.
13. Write down LED string #2 RMS voltage and RMS current. Calculate output power multiplying those values.
14. Turn AC power supply OFF.



15. Rearrange LED board connection to driver board so that LED string #3 current and voltage can be measured.

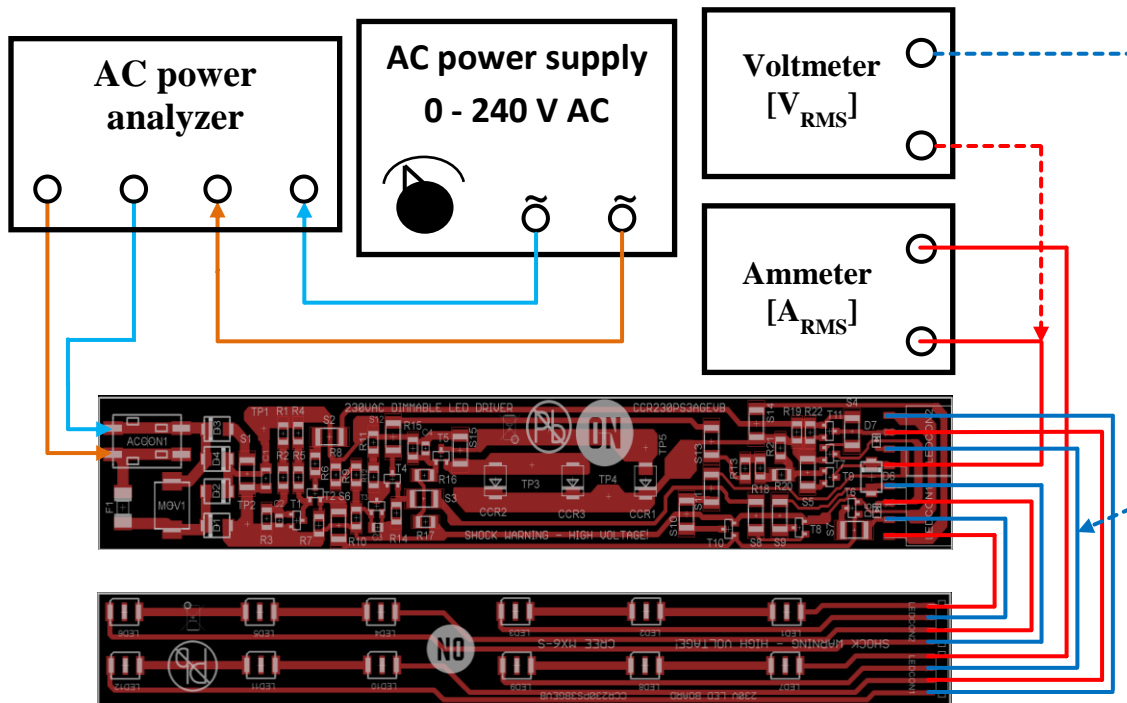

16. Turn AC power supply ON again. Allow circuit to run for 1 minute to stabilize for thermal settling before taking measurements.
17. Check that AC input voltage is still 230VAC.
18. Write down LED string #3 RMS voltage and RMS current. Calculate output power multiplying those values.
19. Turn AC power supply OFF.



20. Rearrange LED board connection to driver board so that LED string #4 current and voltage can be measured.

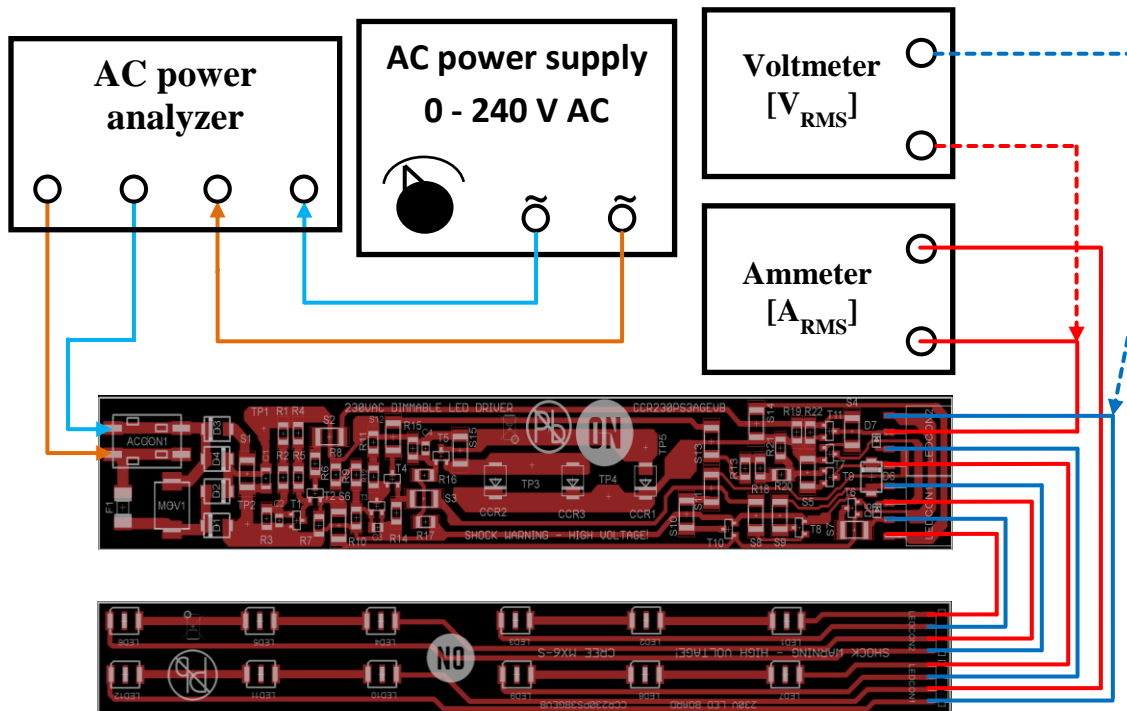

21. Turn AC power supply ON again. Allow circuit to run for 1 minute to stabilize for thermal settling before taking measurements.
22. Check that AC input voltage is still 230VAC.
23. Write down LED string #4 RMS voltage and RMS current. Calculate output power multiplying those values.
24. Turn AC power supply OFF.
25. Calculate driver board efficiency using following formula (expected efficiency is ~75-79%):

$$\eta = \frac{P_{out \text{ LED String \#1}} + P_{out \text{ LED String \#2}} + P_{out \text{ LED String \#3}} + P_{out \text{ LED String \#4}}}{\text{Real AC input power}}$$



Компания «ЭлектроПласт» предлагает заключение долгосрочных отношений при поставках импортных электронных компонентов на взаимовыгодных условиях!

Наши преимущества:

- Оперативные поставки широкого спектра электронных компонентов отечественного и импортного производства напрямую от производителей и с крупнейших мировых складов;
- Поставка более 17-ти миллионов наименований электронных компонентов;
- Поставка сложных, дефицитных, либо снятых с производства позиций;
- Оперативные сроки поставки под заказ (от 5 рабочих дней);
- Экспресс доставка в любую точку России;
- Техническая поддержка проекта, помощь в подборе аналогов, поставка прототипов;
- Система менеджмента качества сертифицирована по Международному стандарту ISO 9001;
- Лицензия ФСБ на осуществление работ с использованием сведений, составляющих государственную тайну;
- Поставка специализированных компонентов (Xilinx, Altera, Analog Devices, Intersil, Interpoint, Microsemi, Aeroflex, Peregrine, Syfer, Eurofarad, Texas Instrument, Miteq, Cobham, E2V, MA-COM, Hittite, Mini-Circuits, General Dynamics и др.);

Помимо этого, одним из направлений компании «ЭлектроПласт» является направление «Источники питания». Мы предлагаем Вам помощь Конструкторского отдела:

- Подбор оптимального решения, техническое обоснование при выборе компонента;
- Подбор аналогов;
- Консультации по применению компонента;
- Поставка образцов и прототипов;
- Техническая поддержка проекта;
- Защита от снятия компонента с производства.



Как с нами связаться

Телефон: 8 (812) 309 58 32 (многоканальный)

Факс: 8 (812) 320-02-42

Электронная почта: org@eplast1.ru

Адрес: 198099, г. Санкт-Петербург, ул. Калинина, дом 2, корпус 4, литера А.