

Mini-ITX Series

VIA EPIA-M910

Highly-integrated Mini-ITX board with rich feature set and multiple expansion options

Features

- Compact 17cm x 17cm Mini-ITX form factor
- 1.2GHz VIA QuadCore E-Series/1.6GHz VIA Nano® X2 E-Series processor
- Fanless 1.0GHz VIA Eden® X2 processor option
- DX9 graphics with MPEG-2/WMV9/VC1/H.264 decoding acceleration
- Rich feature set

Board Placement

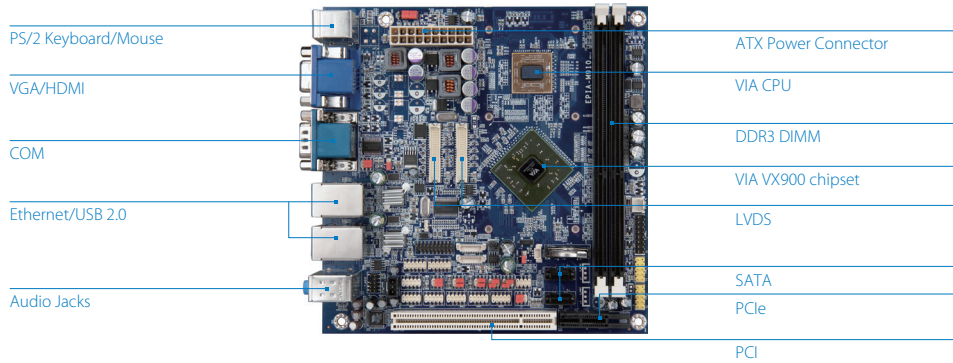

Specifications

Model Name	EPIA-M910-12Q/PQ	EPIA-M910-16/P	EPIA-M910-10E/PE
Processor	1.2GHz VIA QuadCore E-Series (with fan)	1.6GHz VIA Nano® X2 E-Series (with fan)	1.0GHz VIA Eden® X2 (fanless)
Chipset	VIA VX900 Media System Processor		
BIOS	AMI BIOS, 8Mbit Flash memory		
System Memory	2 DDR3 1066 DIMM sockets Up to 4GB memory size per slot		
Storage	2 SATA connectors		
Graphics	Integrated VIA Chrome®9 HD DX9 3D/2D graphics with MPEG-2, WMV9, VC1 and H.264 video decoding acceleration		
LAN	2 VIA VT6130 PCIe Gigabit Ethernet controllers		
Audio	VIA VT2021 High Definition Audio Codec		
Super I/O	Fintek F81865F-I + F81801		
Expansion I/O	1 PCI slot 1 PCIe x1 slot		
Onboard I/O	2 SATA connectors 2 SATA power connectors (DC-in SKU), 2 SATA DOM power selectors 2 USB 2.0 pin headers for 4 ports 1 Dual-channel 18/24-bit LVDS panel connector 1 Single-channel 18/24-bit LVDS panel connector 6 COM port pin headers (powered with selectable 5V/12V) 1 LPC pin header 1 SMBus pin header 1 S/PDIF-out connector 2 Digital I/O pin headers (8 GPI + 8 GPO) 1 Front audio pin header for Line-out, Mic-in 2 Smart Fan pin headers for CPU and system 1 ATX or DC-in power connector 1 PCI slot 1 PCIe x1 slot		
Back Panel I/O	4 USB ports 1 HDMI port 1 VGA port 2 COM ports (powered with selectable 5V/12V) 2 Gigabit Ethernet ports 3 Audio jacks: Line-in, Line-out and Mic-in 2 PS/2 keyboard/mouse ports		
Power Supply	ATX power connector or 12V DC-in		
Operating System	Windows 7, WES 7, Windows CE, Linux, POSReady 7		
System Monitoring & Management	Wake-on-LAN, Keyboard Power-on, Timer Power-on, System power management, AC power failure recovery, Watch Dog Timer		
Operating Temperature	0°C ~ 60°C		
Operating Humidity	0% ~ 95% (non-condensing)		
Form Factor	Mini-ITX (17cm x 17cm, 6.7" x 6.7")		
Compliance	CE/FCC		



Back Panel I/O

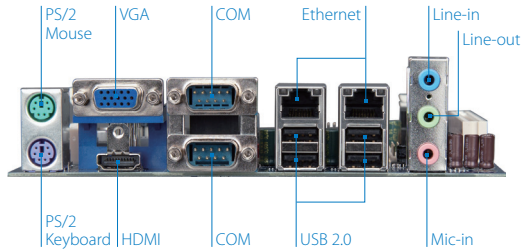

Accessories

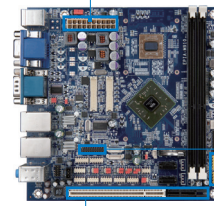

PWB-M120
120W DC-DC power board,
voltage range from 12V~24V



LPC-01/02/04
Up to 4 additional COM ports



EMIO-1533 USB Wi-Fi Module
802.11b/g/n standards



PCIE-03
PCI & 1-lane PCIe riser card



EXT-PCI
One to two PCI riser card

Ordering Information

Model Name	CPU Frequency	Description
EPIA-M910-12Q	VIA QuadCore E-Series @ 1.2GHz	Mini-ITX Board with 1.2GHz VIA QuadCore E-Series CPU with HDMI, VGA, 2 LVDS, 8 USB 2.0, 8 COM, 2 Gigabit Ethernet, 2 SATA, PCI slot, PCIe x1 slot, ATX power connector
EPIA-M910-12PQ	VIA QuadCore E-Series @ 1.2GHz	Mini-ITX Board with 1.2GHz VIA QuadCore E-Series CPU with HDMI, VGA, 2 LVDS, 8 USB 2.0, 8 COM, 2 Gigabit Ethernet, 2 SATA, PCI slot, PCIe x1 slot, 12V DC-in
EPIA-M910-16	VIA Nano® X2 E-Series @ 1.6GHz	Mini-ITX Board with 1.6GHz VIA Nano® X2 E-Series CPU with HDMI, VGA, 2 LVDS, 8 USB 2.0, 8 COM, 2 Gigabit Ethernet, 2 SATA, PCI slot, PCIe x1 slot, ATX power connector
EPIA-M910-16P	VIA Nano® X2 E-Series @ 1.6GHz	Mini-ITX Board with 1.6GHz VIA Nano® X2 E-Series CPU with HDMI, VGA, 2 LVDS, 8 USB 2.0, 8 COM, 2 Gigabit Ethernet, 2 SATA, PCI slot, PCIe x1 slot, 12V DC-in
EPIA-M910-10E	VIA Eden® X2 @ 1.0GHz	Mini-ITX Board with 1.0GHz VIA Eden® X2 CPU with HDMI, VGA, 2 LVDS, 8 USB 2.0, 8 COM, 2 Gigabit Ethernet, 2 SATA, PCI slot, PCIe x1 slot ATX power connector
EPIA-M910-10PE	VIA Eden® X2 @ 1.0GHz	Mini-ITX Board with 1.0GHz VIA Eden® X2 CPU, with HDMI, VGA, 2 LVDS, 8 COM, 8 USB 2.0, 2 Gigabit Ethernet, 2 SATA, PCI slot, PCIe x1 slot, 12V DC-in

Optional Accessories

I/O Expansion Cards

Part Number	Description
LPC-01	Expansion module for four COM ports
LPC-02	Expansion module for four COM ports (5V or 12V)
LPC-04	Expansion module for two or four COM ports (5V or 12V)
PWB-M120	120W DC-DC power board, voltage range from 12V~24V
PCIE-03	PCI & 1-lane PCIe riser card
EXT-PCI	One to two PCI riser card

Wireless Modules

Part Number	Description
EMIO-1533-00A2	VNT9271 IEEE 802.11 b/g/n USB Wi-Fi module with assembly kit

Block Diagram

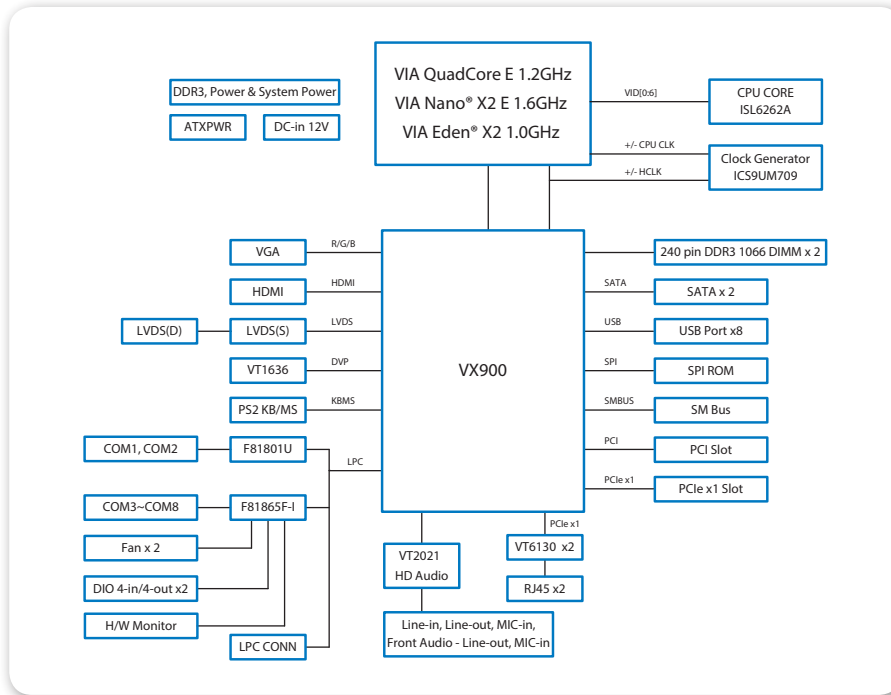

Packing List

Items
EPIA-M910 board
SATA cable
SATA power cable (for DC-in sku only)
DC power cable (for DC-in sku only)
I/O bracket



Компания «ЭлектроПласт» предлагает заключение долгосрочных отношений при поставках импортных электронных компонентов на взаимовыгодных условиях!

Наши преимущества:

- Оперативные поставки широкого спектра электронных компонентов отечественного и импортного производства напрямую от производителей и с крупнейших мировых складов;
- Поставка более 17-ти миллионов наименований электронных компонентов;
- Поставка сложных, дефицитных, либо снятых с производства позиций;
- Оперативные сроки поставки под заказ (от 5 рабочих дней);
- Экспресс доставка в любую точку России;
- Техническая поддержка проекта, помощь в подборе аналогов, поставка прототипов;
- Система менеджмента качества сертифицирована по Международному стандарту ISO 9001;
- Лицензия ФСБ на осуществление работ с использованием сведений, составляющих государственную тайну;
- Поставка специализированных компонентов (Xilinx, Altera, Analog Devices, Intersil, Interpoint, Microsemi, Aeroflex, Peregrine, Syfer, Eurofarad, Texas Instrument, Miteq, Cobham, E2V, MA-COM, Hittite, Mini-Circuits, General Dynamics и др.);

Помимо этого, одним из направлений компании «ЭлектроПласт» является направление «Источники питания». Мы предлагаем Вам помощь Конструкторского отдела:

- Подбор оптимального решения, техническое обоснование при выборе компонента;
- Подбор аналогов;
- Консультации по применению компонента;
- Поставка образцов и прототипов;
- Техническая поддержка проекта;
- Защита от снятия компонента с производства.



Как с нами связаться

Телефон: 8 (812) 309 58 32 (многоканальный)

Факс: 8 (812) 320-02-42

Электронная почта: org@eplast1.ru

Адрес: 198099, г. Санкт-Петербург, ул. Калинина, дом 2, корпус 4, литера А.