

Robust, instant connections for harsh environments

The all metal construction 6000 Series Buccaneer - circular connectors that combine the ease of use of a push/pull coupling mechanism with proven environmental sealing for signal and mains power.

Designed and independently tested to IP66, IP68 & IP69K standards, they are ideal for applications where ingress of dust and water must be avoided and where ease of connection, space and appearance are important considerations



For Power

METAL VERSION

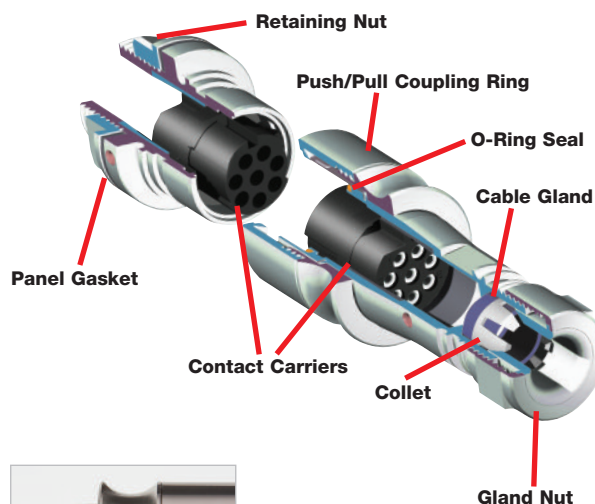

● Push/pull latching mechanism*	Secure, instant latching. Quick connector mating and release
● 30° twist locking*	Tamperproof lock prevents accidental un-mating
● IP66, IP68 and IP69K when mated	Suitable for a wide range of dust and water borne environments
● All metal body version; brass, nickel plated	Robust construction offering protection against EMI
● Flex, flex in-line & panel mount body styles, with sealing caps	Complete family of products maintain sealing integrity in all styles
● Polarisation and visual alignment features	Aids the correct mating of connectors
● 2 to 22 poles – up to 16A, 277V rated	Suitable for mains power to signal applications
● 'Scoop proof' contacts	Prevents damage through mis-mating – ideal for 'blind mating' applications
● Cable braid termination accessory	Maintains continuity between cable screen and connector body
● cULus, VDE, CCC approvals (pending)	Internationally recognised certification

*patent applied for

6000 Series Buccaneer®



Metal Version

FLEX CABLE CONNECTOR



PXM6010/P

- Mates with In-Line Flex or Panel Mounting versions PXM6011 and PXM6012
- Push/pull locking ring with 30° twist locking
- Pin or socket versions
- Leading earth on 3 pole connectors
- 2, 3, 8, 16 and 22 pole
- Screw and crimp termination
- Cable braid termination accessory option, add /SN suffix

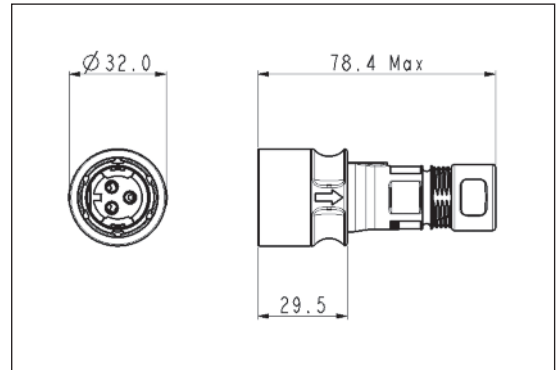

Poles	Termination	Pin Contacts	Socket Contacts	Contacts
2	Screw	PXM6010/02P/ST	PXM6010/02S/ST	Supplied Fitted
2	Crimp	PXM6010/02P/CR	PXM6010/02S/CR	Order Separately
3	Screw	PXM6010/03P/ST	PXM6010/03S/ST	Supplied Fitted
3	Crimp	PXM6010/03P/CR	PXM6010/03S/CR	Order Separately
8	Crimp	PXM6010/08P/CR	PXM6010/08S/CR	Order Separately
16	Crimp	PXM6010/16P/CR	PXM6010/16S/CR	Order Separately
22	Crimp	PXM6010/22P/CR	PXM6010/22S/CR	Order Separately

IN-LINE FLEX CABLE CONNECTOR



PXM6011/S

- Mates with Flex Cable connector PXM6010
- For in-line cable connection
- Pin or socket versions
- Leading earth on 3 pole connectors
- 2, 3, 8, 16 and 22 pole
- Screw and crimp termination
- Cable braid termination accessory option, add /SN suffix

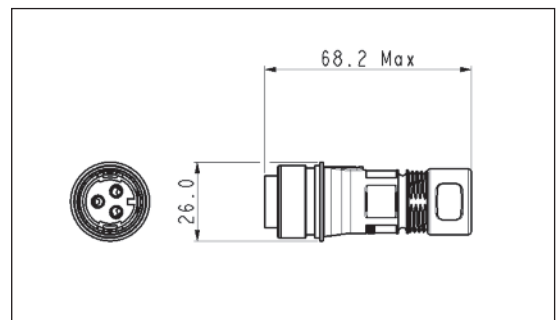

Poles	Termination	Pin Contacts	Socket Contacts	Contacts
2	Screw	PXM6011/02P/ST	PXM6011/02S/ST	Supplied Fitted
2	Crimp	PXM6011/02P/CR	PXM6011/02S/CR	Order separately
3	Screw	PXM6011/03P/ST	PXM6011/03S/ST	Supplied Fitted
3	Crimp	PXM6011/03P/CR	PXM6011/03S/CR	Order separately
8	Crimp	PXM6011/08P/CR	PXM6011/08S/CR	Order separately
16	Crimp	PXM6011/16P/CR	PXM6011/16S/CR	Order separately
22	Crimp	PXM6011/22P/CR	PXM6011/22S/CR	Order separately

FRONT PANEL MOUNTING CONNECTOR



PXM6012/S

- Mates with Flex Cable connectors PXM6010
- Front panel mounting
- Single hole fixing
- Pin or socket versions
- Leading earth on 3 pole connectors
- 2, 3, 8, 16 and 22 pole
- Screw and crimp termination

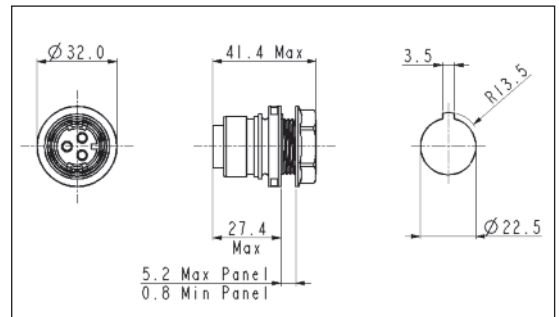

Poles	Termination	Pin Contacts	Socket Contacts	Contacts
2	Screw	PXM6012/02P/ST	PXM6012/02S/ST	Supplied Fitted
2	Crimp	PXM6012/02P/CR	PXM6012/02S/CR	Order separately
3	Screw	PXM6012/03P/ST	PXM6012/03S/ST	Supplied Fitted
3	Crimp	PXM6012/03P/CR	PXM6012/03S/CR	Order separately
8	Crimp	PXM6012/08P/CR	PXM6012/08S/CR	Order separately
16	Crimp	PXM6012/16P/CR	PXM6012/16S/CR	Order separately
22	Crimp	PXM6012/22P/CR	PXM6012/22S/CR	Order separately

Metal Version

CRIMP CONTACTS



2, 3, 8, 16 & 22 pole contacts

- Crimp Contacts
- Gold Plated
- Current ratings:
 - 2 & 3 pole : 16A
 - 8 pole : 10A
 - 16 pole : 3A
 - 22 pole : 2A

Contacts - Crimp for 2, 3, 8, 16 and 22 pole

Contacts (for 2 & 3 pole) (Supplied in packs of 10)

	Crimp
Pins	SA3545/P
Sockets	SA3545/S

Contacts (for 8 pole) (Supplied in packs of 10)

	Crimp
Pins	SA3544/P
Sockets	SA3544/S

Contacts (for 16 & 22 pole) (Supplied in packs of 10)

	Crimp
Pins	SA3542/P
Sockets	SA3542/S

CRIMP TOOLING



PN 14232

- Crimp Tools for 2, 3, 8, 16 and 22 pole crimp contacts

Crimp Tooling

Crimp Tool (2 & 3 pole)	PN 14232
Positioner (2 & 3 pole)	PN 14232/2/SP
Crimp Tool (8, 16 & 22 pole)	PN 14025
Positioner (8 pole)	PN 15021/SP
Positioner (16 & 22 pole)	PN 15019/SP

INSERTION/EXTRACTION TOOLS



PN 14946

- Insertion/Extraction Tool for 2, 3, 8, 16 and 22 pole contacts

Insertion/Extraction Tools

Insertion/Extraction Tool (2 & 3 pole)	PN 14946/SP
Insertion/Extraction Tool (8 pole)	PN 14945/SP
Insertion/Extraction Tool (16 & 22 pole)	PN 14944/SP

CONTACT CARRIER REMOVAL TOOL



PN 14917

- For removal of all contact carriers

Tools

Contact carrier removal tool (all poles)	PN 14917/SP
--	-------------

Metal Version

SEALING CAPS



- Maintains IP Rating of Unmated Connectors
- PXM6081: Fits PXM6010 (Flex Connector)
- PXM6082: Fits PXM6011 (Flex In-Line Connector)
- PXM6083: Fits PXM6012 (Panel Connector)

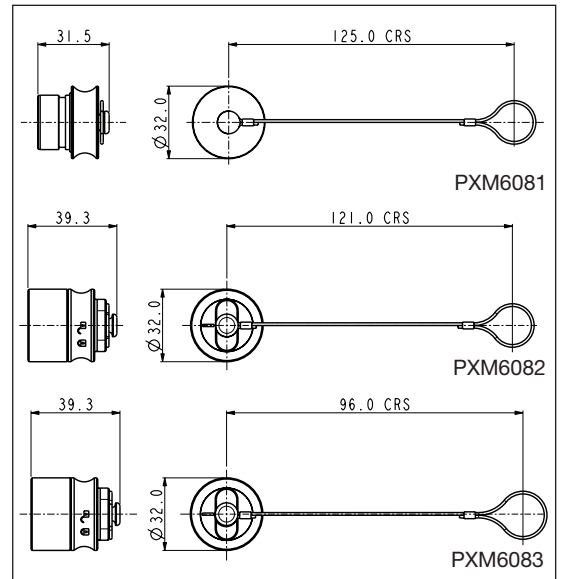

CABLE GLAND PACKS



- Pack of all cable glands to suit cable ranges from 4.0 to 10.0mm diameter

CABLE BRAID TERMINATION OPTION



- For cable braid termination
- Supplied with ty-rap

Metal Version

PART NO SYSTEM

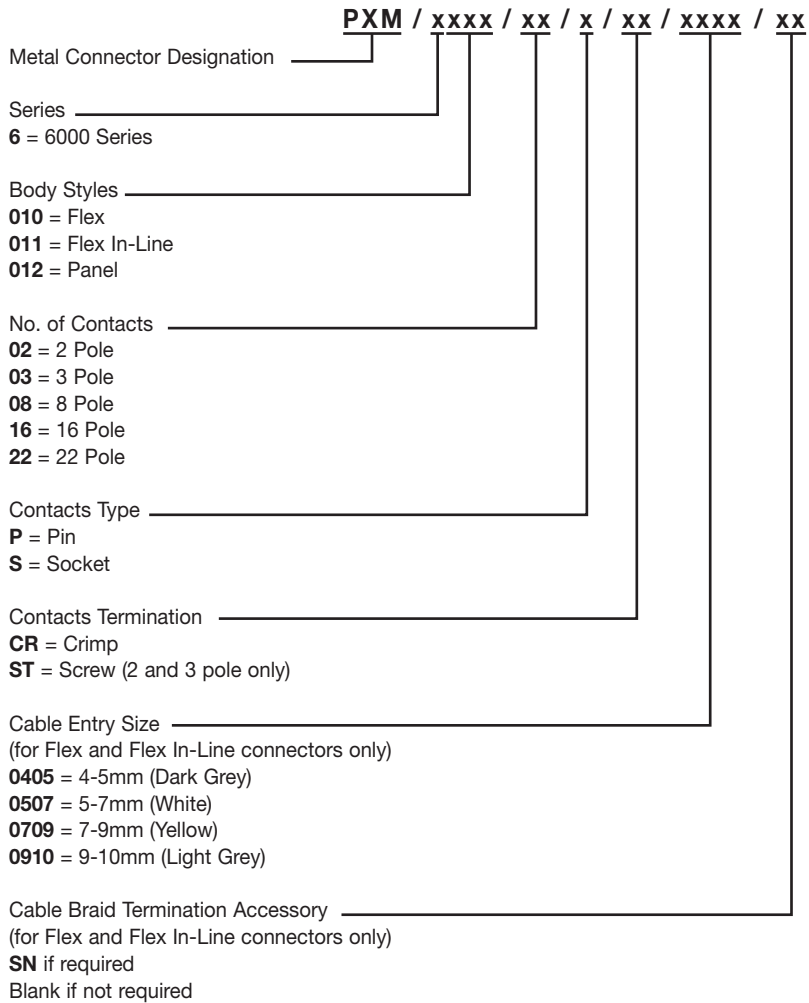

Examples:

PXM6010/03/P/CR/0507= Flex cable connector, 3 pole, pin contacts, crimp termination with 5 to 7mm cable glands

PXM6012/03/S/ST= Front panel mounting connector, 3 pole, socket with screw termination

Metal Version

SPECIFICATION

Electrical:						Mechanical:		
No. Poles:	2	3	8	16	22	Locking mechanism	Push/pull with 30° locking Patent applied for	
Rated cable	18	18	18	22	26	Sealing:	IP66 to EN60529:1992 IP68 to EN60529:1992 (10m depth for 2 weeks) IP69k to DIN 40050-9	
	AWG	AWG	AWG	AWG	AWG			
Current Rating: See de-rating curves for further information						Contact Accommodation:	14 to 18AWG 1.5mm ² max 18 to 20AWG 22 to 26AWG 22 to 26AWG	
CCC, UL and VDE (pending)	16A	12A	10A	3A	3A	2 & 3 pole crimp		
cUL (pending)	13A	12A	10A	3A	3A	2 & 3 pole screw terminals		
Voltage Rating (ac/dc):	277V	277V	277V	60V	60V	8 pole crimp		
Contact Resistance:	<10mΩ					16 pole crimp		
Insulation Resistance:	>10 ⁹ MΩ @500V dc					22 pole crimp		
AC Breakdown voltage:						Cable Acceptance:	4-10mm dia.	
2 pole	>10kV					Cable retention force (to BS EN61984):		
3 pole	>8kV					4 - 9mm dia cable	80N	
8 to 22 pole	>5kV					9 - 10mm dia cable	100N	
Operating Temp. Range:	-40°C to +120°C					Terminations:		
Approvals (pending):						2 Pole:	Screw Terminals	
UL	UL1977					3 Pole:	Screw Terminals & Crimp Contacts	
CSA	C22.2 No.182.3-M1987 (R2009)					8 Pole:	Crimp Contacts	
VDE	IEC 61984:2009					16 Pole:	Crimp Contacts	
CCC	GB/T11918 and GB/T11919					22 Pole:	Crimp Contacts	
Material:						Tightening Torques:		
Body:	Brass, Nickel plated					Gland Nut:	1.13Nm (10lb.in)	
Colour:	Matt Silver					Panel Nut:	1.7Nm (15lb.in.)	
Contacts:	Brass, Nickel plated (2A – Gold plated)					Panel Nut Thread:	M22 x 1.5-6g	
O Rings & Gaskets:	Silicon					Dimensions:		
RoHS	Compliant					Diameter: (over coupling ring)	32mm	
						Diameter: (panel hole cut-out)	22.5mm	

Mated dimensions - Flex to panel connector

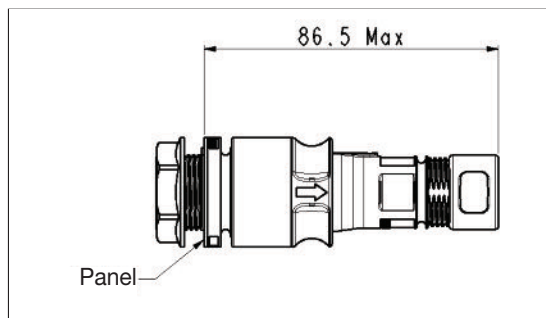

Mated dimensions - Flex connector to in-line connector

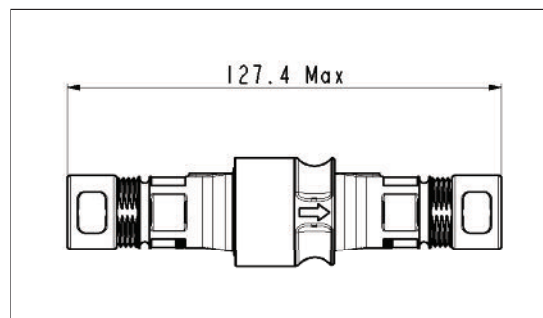

Metal Version

CURRENT CARRYING CAPACITY

The thermal properties of the materials used in the construction of a connector limit the current carrying capacity. There are a number of factors that determine the amount of current that can be handled: contact spacing, size of cable, ambient temperature and the heat that is generated by the current passing through the connector.

The maximum current varies with different contact layouts, and because of these factors it is necessary to produce de-rating curves for each pole variant. This de-rating curve is specified in the standard IEC 60512 part 3.

De-rating curves are plotted for each contact combination with the current being carried simultaneously by all contacts. These graphs show the heat rise generated as the current is increased.

The red line indicates the direct correlation between current applied and the measured temperature rise within the connector. The dotted blue line shows rated current and the green line is derived by applying a factor of 0.8 to the original plot data to give a de-rating curve. The dashed blue line shows the rated current.

The shaded area under the 0.8 curve shows the permitted operating area, and allows safe current vs ambient temperature characteristics to be determined.

- = tested operating limits
- = de-rated operating limits
- - - = rated current

2 Pole, Metal Body, Crimp Terminal, 18 AWG wire
current applied through all pins simultaneously

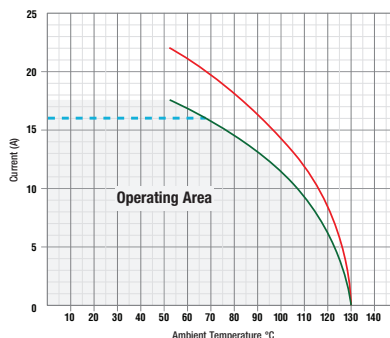

3 Pole, Metal Body, Screw Terminal, 18 AWG wire
current applied through all pins simultaneously

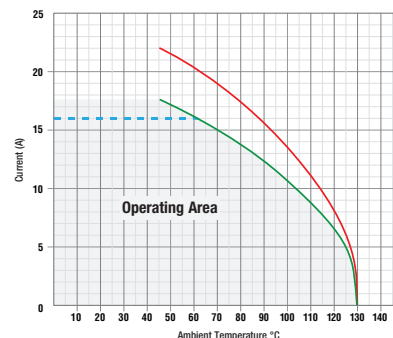

8 Pole, Metal Body, Crimp Terminal, 18 AWG wire
current applied through all pins simultaneously

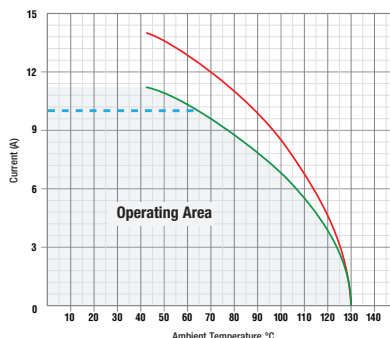

8 Pole, Metal Body, Crimp Terminal, 20 AWG wire
current applied through all pins simultaneously

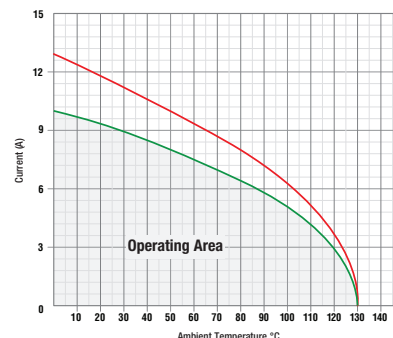

16 Pole, Metal Body, Crimp Terminal, 22 AWG wire
current applied through all pins simultaneously

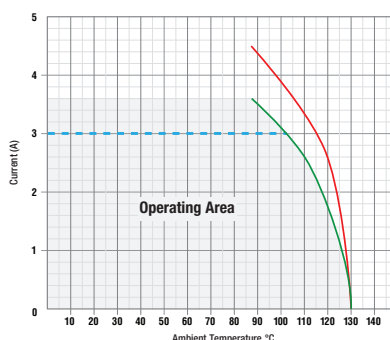

16 Pole, Metal Body, Crimp Terminal, 26 AWG wire
current applied through all pins simultaneously

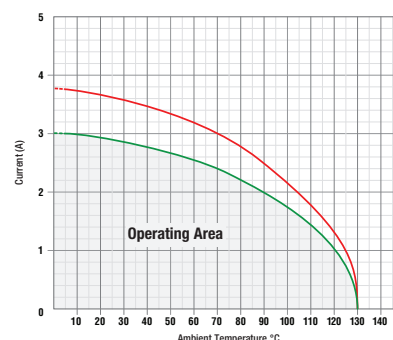

22 Pole, Metal Body, Crimp Terminal, 26 AWG wire
current applied through all pins simultaneously

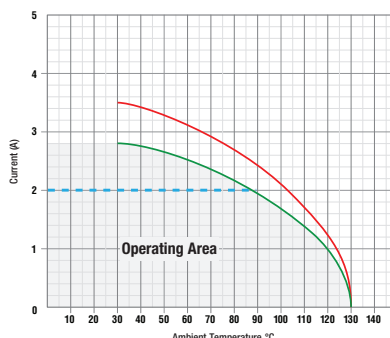



Компания «ЭлектроПласт» предлагает заключение долгосрочных отношений при поставках импортных электронных компонентов на взаимовыгодных условиях!

Наши преимущества:

- Оперативные поставки широкого спектра электронных компонентов отечественного и импортного производства напрямую от производителей и с крупнейших мировых складов;
- Поставка более 17-ти миллионов наименований электронных компонентов;
- Поставка сложных, дефицитных, либо снятых с производства позиций;
- Оперативные сроки поставки под заказ (от 5 рабочих дней);
- Экспресс доставка в любую точку России;
- Техническая поддержка проекта, помощь в подборе аналогов, поставка прототипов;
- Система менеджмента качества сертифицирована по Международному стандарту ISO 9001;
- Лицензия ФСБ на осуществление работ с использованием сведений, составляющих государственную тайну;
- Поставка специализированных компонентов (Xilinx, Altera, Analog Devices, Intersil, Interpoint, Microsemi, Aeroflex, Peregrine, Syfer, Eurofarad, Texas Instrument, Miteq, Cobham, E2V, MA-COM, Hittite, Mini-Circuits, General Dynamics и др.);

Помимо этого, одним из направлений компании «ЭлектроПласт» является направление «Источники питания». Мы предлагаем Вам помощь Конструкторского отдела:

- Подбор оптимального решения, техническое обоснование при выборе компонента;
- Подбор аналогов;
- Консультации по применению компонента;
- Поставка образцов и прототипов;
- Техническая поддержка проекта;
- Защита от снятия компонента с производства.



Как с нами связаться

Телефон: 8 (812) 309 58 32 (многоканальный)

Факс: 8 (812) 320-02-42

Электронная почта: org@eplast1.ru

Адрес: 198099, г. Санкт-Петербург, ул. Калинина, дом 2, корпус 4, литера А.