

Datasheet SGPC3

Indoor Air Quality Sensor for TVOC Measurements

- Ultra-low power gas sensor for indoor air quality applications
- Outstanding long-term stability
- Ultra-low power consumption: 0.065 mA at 1.8V
- I²C interface with TVOC output signal
- Very small 6-pin DFN package: 2.45 x 2.45 x 0.9 mm³
- Tape and reel packaged, reflow solderable



Product Summary

The SGPC3 is a digital ultra-low power gas sensor designed for mobile and battery-driven indoor air quality applications. Sensirion's CMOSens[®] technology offers a complete sensor system on a single chip featuring a digital I²C interface, a temperature-controlled micro-hotplate and a preprocessed indoor air quality signal. The sensing element features an unmatched robustness against contamination by siloxanes present in real-world applications enabling a unique long-term stability and low drift.

The very small 2.45 x 2.45 x 0.9 mm³ DFN package and its ultra-low power consumption make the SGPC3 perfectly suited for mobile and wearable applications. Sensirion's state-of-the-art production process guarantees high reproducibility and reliability. Tape and reel packaging, together with suitability for standard SMD assembly processes make the SGPC3 predestined for high-volume applications.

Block Diagram

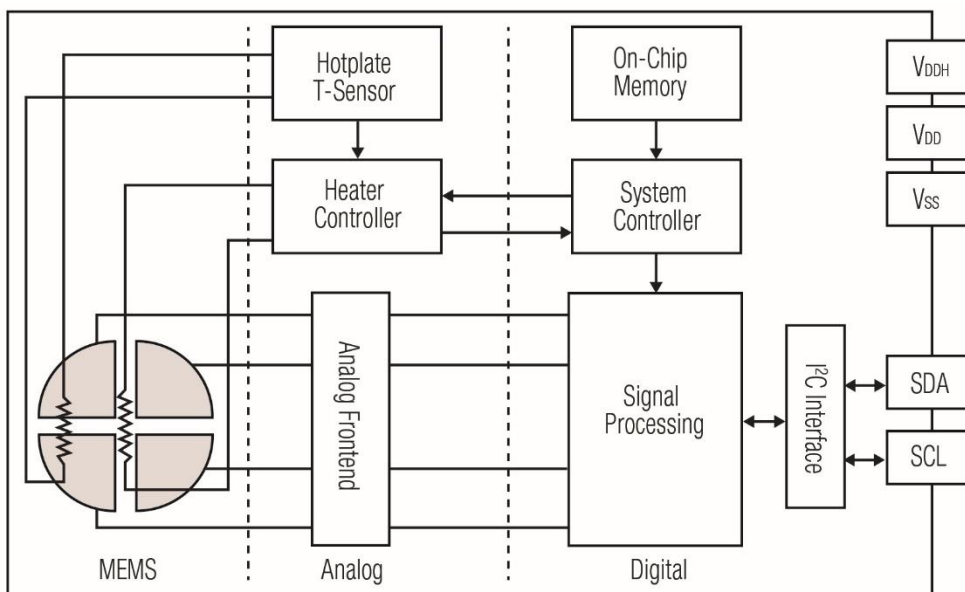

Figure 1 Functional block diagram of the SGPC3.

1 Sensor Performance

1.1 Gas Sensing Performance

Parameter	Signal	Values	Comments
Measurement range ¹	Ethanol signal	0 ppm to 1000 ppm	
Specified range	Ethanol signal	0.3 ppm ² to 30 ppm	The specifications below are defined for this measurement range. The specified measurement range covers the gas concentrations expected in indoor air quality applications.
Relative accuracy ³	Ethanol signal	see Figure 2 typ.: 15% of meas. value	Accuracy is defined as $\frac{c - c_{set}}{c_{set}}$ with c the measured concentration and c_{set} the concentration set point. The concentration c is determined by $c = c_{ref} \cdot \exp\left(\frac{S_{ref} - S_{out}}{512}\right)$ with S_{out} : Ethanol signal output at concentration c S_{ref} : Ethanol signal output at concentration $c_{ref} = 0.18$ ppm
Long-term drift ⁴	Ethanol signal	see Figure 3 typ.: 1.3% of meas. value	Change of accuracy over time: Siloxane accelerated lifetime test ⁵
Resolution	Ethanol signal	0.2 % of meas. value	Resolution of Ethanol signal output in relative change of the measured concentration
Sampling time	Ethanol signal	Low power mode: 2s	The on-chip baseline algorithm has been optimized for these sampling rates. The sensor shows best performance when used with this sampling rate.
		Ultralow power mode: 30s	

Table 1 Gas sensing performance. Specifications are at 25°C, 50% RH and typical VDD. All parameters are determined for the low-power operation mode with one measurement every 2s. The sensors have been operated for at least 24h before the first characterization.

¹ Exposure to ethanol and H₂ concentrations up to 1000 ppm have been tested. For applications requiring the measurement of higher gas concentrations please contact Sensirion.

² ppm: parts per million. 1 ppm = 1000 ppb (parts per billion)

³ 90% of the sensors will be within the typical accuracy tolerance, >99% are within the maximum tolerance.

⁴ The long-term drift is stated as change of accuracy per year of operation.

⁵ Test conditions: operation in 250 ppm Decamethylcyclopentasiloxane (D5) for 200h simulating 10 years of operation in an indoor environment.

Accuracy Ethanol signal

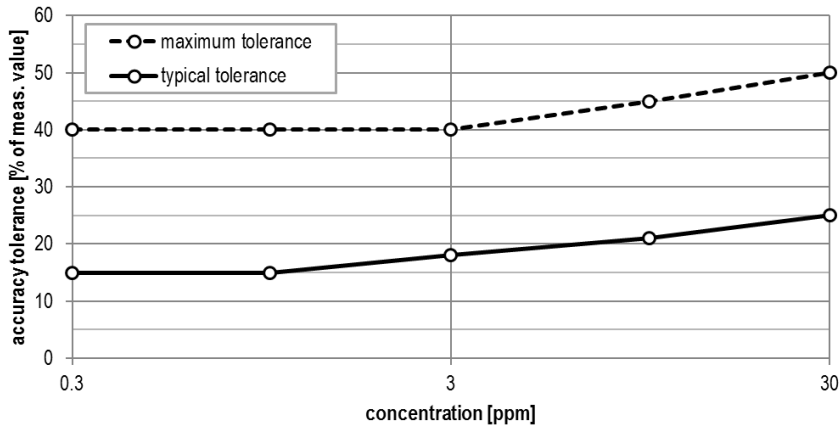

Figure 2 Typical and maximum accuracy tolerance for the low-power operation mode in % of measured value at 25°C, 50% RH and typical VDD. The sensors have been operated for at least 24h before the characterization.

Long-term drift Ethanol signal

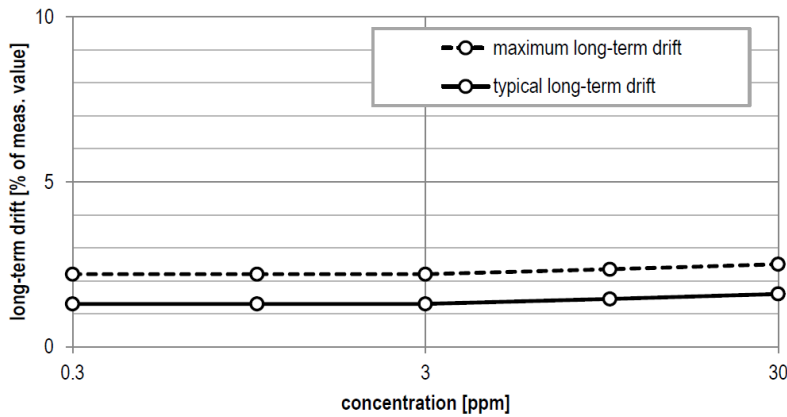

Figure 3 Typical and maximum long-term drift in % of measured value for the low-power operation mode at 25°C, 50% RH and typical VDD. The sensors have been operated for at least 24h before the first characterization.

1.2 Air Quality Signal

Air quality signal TVOC is calculated from Ethanol measurements using internal conversion and baseline compensation algorithms (see **Figure 4**).

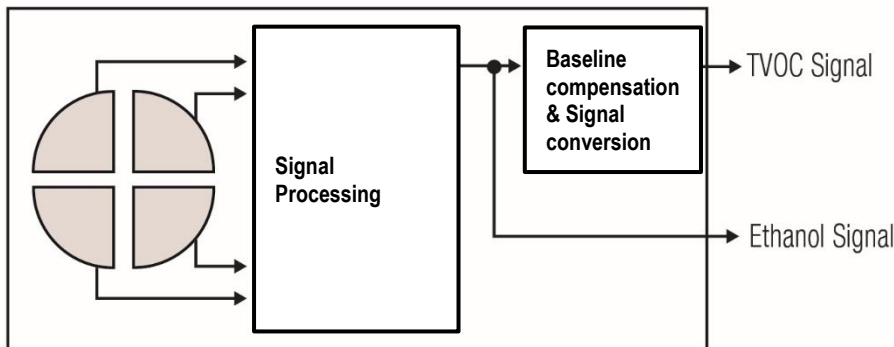

Figure 4 Simplified version of the functional block diagram (compare Figure 1) showing the signal paths of the SGPC3.

Specifications of air quality signals are shown in **Table 2**.

Parameter	Signal	Values		Comments
Output range	TVOC signal	0 ppb to 60000 ppb		Maximum possible output range. The gas sensing performance is specified for the measurement range as defined in Table 1
		Range	Resolution	
	TVOC signal	0 ppb - 2008 ppb	1 ppb	
		2008 ppb – 11110 ppb	6 ppb	
		11110 ppb – 60000 ppb	32 ppb	
Sampling interval	TVOC signal	Low power mode: 2s		The on-chip baseline algorithm has been optimized for these sampling rates. The sensor shows best performance when used with this sampling rate.
		Ultra-low power mode: 30s		

Table 2 Air quality signal specifications.

1.3 Recommended Operating and Storage Conditions

Gas Sensing Specifications as detailed in **Table 1** are guaranteed only when the sensor is stored and operated under the recommended conditions. Prolonged exposure to conditions outside these conditions may accelerate aging.

The recommended temperature and humidity range for operating the SGPC3 is 5–55 °C and 4–30 g m⁻³ absolute humidity, respectively (see **Figure 5** for the corresponding translation into relative humidity). It is recommended to store the sensor in a temperature range of 5–30 °C and below 30 g m⁻³ absolute humidity (see **Figure 6** for the corresponding translation into relative humidity). The sensor must not be exposed towards condensing conditions (i.e., >90 % relative humidity) at any time. To ensure a stable performance of the SGPC3, conditions described in the document SGP Handling Instructions have to be met. Please also refer to the Design-in Guide for optimal integration of the SGPC3 into the final device.

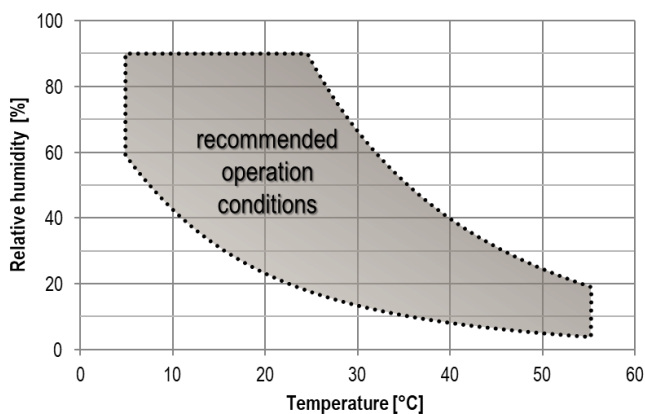

Figure 5 Recommended relative humidity and temperature for operating the SGPC3.

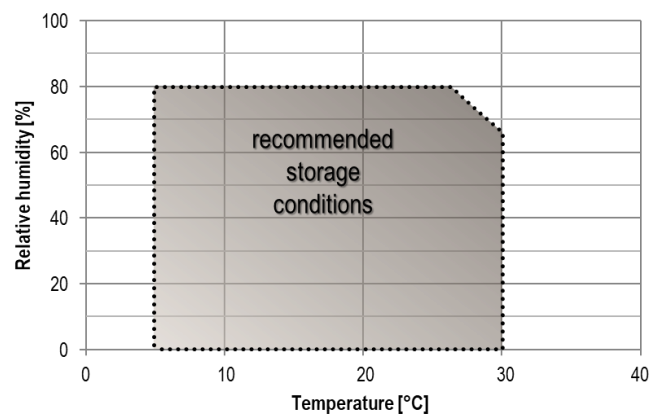

Figure 6 Recommended relative humidity and temperature for storing the SGPC3.

2 Electrical Specifications

Parameter	Min.	Typ.	Max.	Unit	Comments
Supply voltage V_{DD}	1.62	1.8	1.98	V	Minimal voltage must be guaranteed also for the maximum supply current specified in this table.
Hotplate supply voltage V_{DDH}	1.62	1.8	1.98	V	
Supply current in measurement mode ⁶		48.8		mA	The measurement mode is activated for 40 ms by sending an "sgpc3_measure_tvoc", "sgpc3_measure_raw" or "sgpc3_measure_tvoc_and_raw" command. After 40 ms, the sensor will be set into sleep mode. Specified at 25°C and typical VDD.
Average supply current low power mode		0.98		mA	Average supply current with one measurement every 2s.
Average supply current ultra-low power mode		0.065		mA	Average supply current with one measurement every 30s.
Sleep current		2	10	μA	
LOW-level input voltage	-0.5		0.3*VDD	V	
HIGH-level input voltage	0.7*VDD		VDD+0.5	V	
Vhys hysteresis of Schmitt trigger inputs			0.05*VDD	V	
LOW-level output voltage			0.2*VDD	V	(open-drain) at 2mA sink current
Communication	Digital 2-wire interface, I ² C fast mode.				

Table 3 Electrical specifications.

3 Interface Specifications

The SGPC3 comes in a 6-pin DFN package, see **Table 4**.

Pin	Name	Comments
1	V_{DD}	Supply voltage
2	V_{SS}	Ground
3	SDA	Serial data, bidirectional
4	R	Connect to ground (no electrical function)
5	V_{DDH}	Supply voltage, hotplate
6	SCL	Serial clock, bidirectional

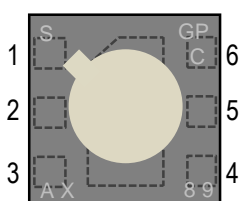

Table 4 Pin assignment (transparent top view). Dashed lines are only visible from the bottom.

⁶ A 20% higher current is drawn during 5ms on V_{DDH} after entering the measurement mode.

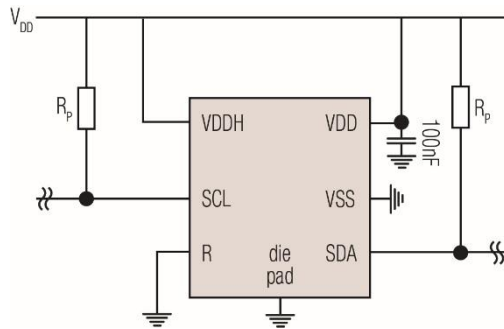

Figure 7 Typical application circuit (for better clarity in the image, the positioning of the pins does not reflect the positions on the real sensor).

The electrical specifications of the SGPC3 are shown in **Table 3**. The power supply pins must be decoupled with a 100 nF capacitor that shall be placed as close as possible to pin VDD – see **Figure 7**. The required decoupling depends on the power supply network connected to the sensor. We also recommend VDD and VDDH pins to be shorted.

SCL is used to synchronize the communication between the microcontroller and the sensor. The SDA pin is used to transfer data to and from the sensor. For safe communication, the timing specifications defined in the I²C manual⁷ must be met. Both SCL and SDA lines are open-drain I/Os with diodes to VDD and VSS. They should be connected to external pull-up resistors. To avoid signal contention, the microcontroller must only drive SDA and SCL low. The external pull-up resistors (e.g. $R_p = 10\text{ k}\Omega$) are required to pull the signal high. For dimensioning resistor sizes please take bus capacity and communication frequency into account (see for example Section 7.1 of NXP's I²C Manual for more details⁷). It should be noted that pull-up resistors may be included in I/O circuits of microcontrollers.

The die pad or center pad is electrically connected to GND. Hence, electrical considerations do not impose constraints on the wiring of the die pad. However, for mechanical stability it is recommended to solder the center pad to the PCB.

4 Absolute Minimum and Maximum Ratings

Stress levels beyond those listed in **Table 5** may cause permanent damage to the device. These are stress ratings for the electrical components only and functional operation of the device at these conditions cannot be guaranteed. Exposure to the absolute maximum rating conditions for extended periods may affect the reliability of the device.

Parameter	Rating
Supply voltage V_{DD}	-0.3 V to +2.16 V
Supply voltage V_{DDH}	-0.3 V to +2.16 V
Storage temperature range	-40 to +125°C
Operating temperature range	-40 to +85°C
Humidity Range	10% - 95% (non-condensing)
ESD HBM	2 kV
ESD CDM	500 V
Latch up, JESD78 Class II, 125°C	100 mA

Table 5 Absolute minimum and maximum ratings.

Please refer to Handling and Assembly Guideline for Sensirion Gas Sensors on Sensirion webpage for full documentation.

⁷ http://www.nxp.com/documents/user_manual/UM10204.pdf

5 Timing Specifications

5.1 Sensor System Timings

Default conditions of 25°C and 1.8 V supply voltage apply to values in the table below, unless otherwise stated. The timings refer to the power up and reset of the ASIC part and do not reflect the usefulness of the readings.

Parameter	Symbol	Condition	Min.	Typ.	Max.	Unit	Comments
Power-up time	t_{PU}	After hard reset, $V_{DD} \geq V_{POR}$	-	0.4	0.6	ms	-
Soft reset time	t_{SR}	After soft reset	-	0.4	0.6	ms	-

Table 6 System timing specifications.

5.2 Communication Timings

Default conditions of 25 °C and 1.8 V supply voltage apply to values in the table below, unless otherwise stated.

Parameter	Symbol	Conditions	Min.	Typ.	Max.	Units	Comments
SCL clock frequency	f_{SCL}	-	0	-	400	kHz	-
Hold time (repeated) START condition	$t_{HD;STA}$	After this period, the first clock pulse is generated	0.6	-	-	μs	-
LOW period of the SCL clock	t_{LOW}	-	1.3	-	-	μs	-
HIGH period of the SCL clock	t_{HIGH}	-	0.6	-	-	μs	-
Set-up time for a repeated START condition	$t_{SU;STA}$	-	0.6	-	-	μs	-
SDA hold time	$t_{HD;DAT}$	-	0	-	-	ns	-
SDA set-up time	$t_{SU;DAT}$	-	100	-	-	ns	-
SCL/SDA rise time	t_R	-	-	-	300	ns	-
SCL/SDA fall time	t_F	-	-	-	300	ns	-
SDA valid time	$t_{VD;DAT}$	-	-	-	0.9	μs	-
Set-up time for STOP condition	$t_{SU;STO}$	-	0.6	-	-	μs	-
Capacitive load on bus line	C_B	-	-	-	400	pF	-

Table 7 Communication timing specifications.

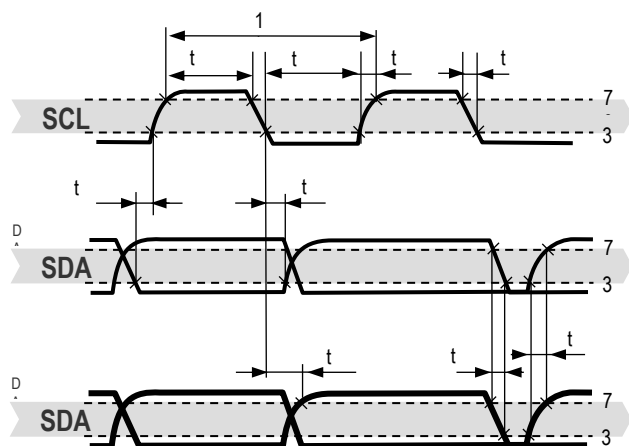

Figure 8 Timing diagram for digital input/output pads. SDA directions are seen from the sensor. Bold SDA lines are controlled by the sensor; plain SDA lines are controlled by the micro-controller. Note that SDA valid read time is triggered by falling edge of preceding toggle.

6 Operation and Communication

The SGPC3 supports I²C fast mode. For detailed information on the I²C protocol, refer to NXP I²C-bus specification⁷. All SGPC3 commands and data are mapped to a 16-bit address space. Additionally, data and commands are protected with a CRC checksum to increase the communication reliability. The 16-bit commands that are sent to the sensor already include a 3-bit CRC checksum. Data sent from and received by the sensor is always succeeded by an 8-bit CRC.

In write direction it is mandatory to transmit the checksum, since the SGPC3 only accepts data if it is followed by the correct checksum. In read direction it is up to the master to decide if it wants to read and process the checksum.

SGPC3	Hex. Code
I ² C address	0x58

Table 8 I²C device address.

The typical communication sequence between the I²C master (e.g., a microcontroller in a host device) and the sensor is described as follows:

1. The sensor is powered up, communication is initialized
2. The I²C master periodically requests measurement and reads data, in the following sequence:
 - a. I²C master sends a measurement command
 - b. I²C master waits until the measurement is finished, either by waiting for the maximum execution time or by waiting for the expected duration and then poll data until the read header is acknowledged by the sensor (expected durations are listed in **Table 10**)
 - c. I²C master reads out the measurement result

6.1 Power-Up and Communication Start

The sensor starts powering-up after reaching the power-up threshold voltage $V_{DD,Min}$ specified in **Table 3****Table 6**. After reaching this threshold voltage, the sensor needs the time t_{PU} to enter the idle state. Once the idle state is entered it is ready to receive commands from the master.

Each transmission sequence begins with a START condition (S) and ends with a STOP condition (P) as described in the I²C-bus specification.

6.2 Measurement Communication Sequence

A measurement communication sequence consists of a START condition, the I²C write header (7-bit I²C device address plus 0 as the write bit) and a 16-bit measurement command. The proper reception of each byte is indicated by the sensor. It pulls the SDA pin low (ACK bit) after the falling edge of the 8th SCL clock to indicate the reception. With the acknowledgement of the measurement command, the SGPC3 starts measuring.

When the measurement is in progress, no communication with the sensor is possible and the sensor aborts the communication with a XCK condition.

After the sensor has completed the measurement, the master can read the measurement results by sending a START condition followed by an I²C read header. The sensor will acknowledge the reception of the read header and responds with data. The response data length is listed in **Table 10** and is structured in data words, where one word consists of two bytes of data followed by one byte CRC checksum. Each byte must be acknowledged by the microcontroller with an ACK condition for the sensor to continue sending data. If the sensor does not receive an ACK from the master after any byte of data, it will not continue sending data.

After receiving the checksum for the last word of data, an XCK and STOP condition have to be sent (see **Figure 10**).

The I²C master can abort the read transfer with a XCK followed by a STOP condition after any data byte if it is not interested in subsequent data, e.g. the CRC byte or following data bytes, in order to save time. Note that the data cannot be read more than once, and access to data beyond the specified amount will return a pattern of 1s.

6.3 Measurement Commands

The available measurement commands of the SGPC3 are listed in **Table 10**.

Set Power Mode

The SGPC3 offers two operation modes with different power consumptions and sampling intervals. The low-power mode with 1mA average current and 2s sampling interval and the ultra-low power mode with 0.065mA average current and 30s sampling interval. By default, the SGPC3 is using the low-power mode.

The sensor can be switched to the ultra-low power operation mode by sending the “sgpc3_set_power_mode” command followed by 2 data bytes (MSB first) with a value of “0x0000” and the corresponding CRC byte. The “sgpc3_set_power_mode” command has to be sent before the “sgpc3_tvoc_init_continuous” command (**Figure 9**). A restart of the sensor (power-up or soft reset) or a “sgpc3_set_power_mode” command followed by a “0x0001” switches the sensor back to the default low-power operation mode.

It is recommended to test the two modes on different SGPC3 sensors, as switching the power mode back and forth with the same sensor will impact sensor accuracy.

Air Quality Signal

The SGPC3 uses a dynamic baseline compensation algorithm and on-chip calibration parameters to provide a preprocessed total VOC signal (TVOC) air quality signal. Sending the “sgpc3_tvoc_init_continuous” commands initializes and starts the air quality measurement. In addition, the “sgpc3_tvoc_init_continuous” command is used to accelerate the switch-on time of the SGPC3. After sending the “sgpc3_tvoc_init_continuous” command, the SGPC3 is operated in a high power operation mode until the first “sgpc3_measure_tvoc” command is sent. During this time interval the hotplate of the SGPC3 is operated continuously with a supply current as indicated in **Table 3** (supply current during measurements).

For air quality measurements the “sgpc3_measure_tvoc” command is used. The “sgpc3_measure_tvoc” command has to be sent in regular intervals of 2s for the low-power operation mode or 30s for the ultra-low power operation mode to ensure proper operation of the dynamic baseline compensation algorithms and the specified power consumption. The sensor responds with 2 data bytes (MSB first) and 1 CRC byte for the preprocessed air quality signal which corresponds to a TVOC concentration in ppb. For the first 20s after the first “sgpc3_measure_tvoc” command the sensor is in an initialization phase during which a “sgpc3_measure_tvoc” command returns a fixed value of 0 ppb.

After every power-up or soft reset, a new “sgpc3_tvoc_init_continuous” command has to be sent. The command sequence after start-up for initializing and repeating measurements is illustrated in **Figure 9**.

Starting the SGPC3 in the low-power mode (default)

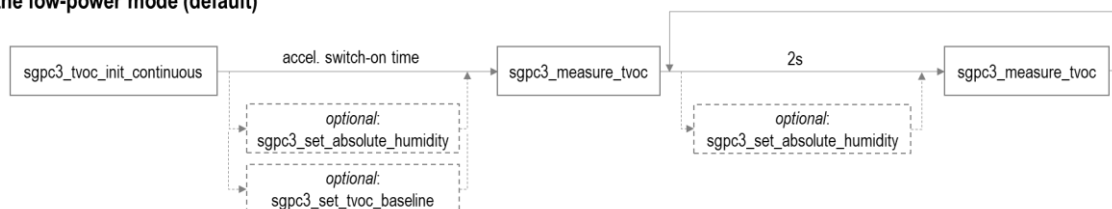

Starting the SGPC3 in the ultra-low power mode

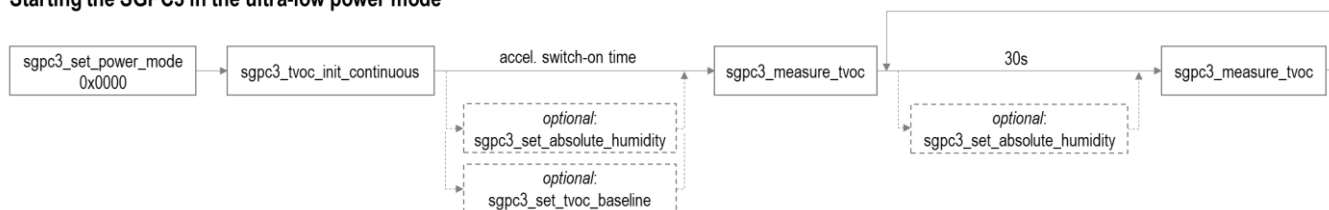

Figure 9 Command sequence for starting the SGPC3 in the low-power and the ultra-low-power mode. An example implementation of a generic driver including recommended time intervals for the accelerated switch-on phase can be found in the document *SGPC3_driver_integration_guide*.

Set and Get Baseline

The SGPC3 provides the possibility to read and write the baseline value of the baseline compensation algorithm. This feature is used to save the baseline in regular intervals on an external non-volatile memory and restore it after a new power-up or soft reset of the sensor. The command “sgpc3_get_tvoc_baseline” returns the baseline value. The sensor responds with 2 data bytes (MSB first) and 1 CRC byte. This value should be stored on the external memory. After a power-up or soft reset, the baseline of the baseline compensation algorithm can be restored by sending first an “sgpc3_tvoc_init_continuous” command followed by a “sgpc3_set_tvoc_baseline” command with the baseline value as a parameter. The baseline value is specific for the operation mode. “sgpc3_get_tvoc_baseline” returns the baseline value for the operation mode set by the “sgpc3_set_power_mode” command.

Inceptive Baseline for TVOC measurements⁸

The inceptive baseline offers an individually calibrated starting reference to the dynamic baseline compensation algorithm. Thereby the feature yields a better TVOC concentration accuracy for the very first start-up under bad air condition. This results in a better user experience especially when accuracy is required. Please note, that the application of this feature is solely limited to the very first start-up period of an SGP sensor. Furthermore, it is limited to the TVOC signal output.

The command “sgpc3_get_tvoc_inceptive_baseline” reads the precalibrated reference point from the sensor HW and “sgpc3_set_tvoc_baseline” activates the inceptive baseline.

Sensor Signals

The command “sgpc3_measure_raw” is intended for part verification and testing purposes. It returns the sensor raw signal for ethanol (S_{out_ETOH}). The ethanol signal is used as input for the on-chip calibration and baseline correction algorithm as shown in **Figure 9**. The command performs a measurement to which the sensor responds with 2 data bytes (MSB first) and 1 CRC byte (see **Figure 10**). The Ethanol signal can be used to calculate gas concentrations c relative to a reference concentration c_{ref} by

$$c = c_{ref} \cdot \exp\left(\frac{S_{ref} - S_{out}}{512}\right)$$

with $S_{out} = S_{out_ETOH}$ and S_{ref} the Ethanol signal output at the corresponding reference concentration c_{ref_ETOH} .

The command “sgpc3_measure_tvoc_and_raw” returns the sensor raw signal (S_{out_ETOH}) and the TVOC air quality signal. This command can be used in place of the “sgpc3_measure_tvoc” or the “sgpc3_measure_raw” command. The command performs a measurement to which the sensor responds with 2 data bytes (MSB first) and 1 CRC byte (see **Figure 10**) each for the Ethanol signal and the TVOC air quality signal in the order Ethanol signal (S_{out_ETOH}) and TVOC air quality signal.

Humidity Compensation

The SGPC3 features an on-chip humidity compensation for the air quality signal and the sensor raw signal (Ethanol signal). To use the on-chip humidity compensation an absolute humidity value from an external humidity sensor like the SHTxx is required. Using the “sgpc3_set_absolute_humidity” command, a new humidity value can be written to the SGPC3 by sending 2 data bytes (MSB first) and 1 CRC byte. The 2 data bytes represent humidity values as a fixed-point 8.8bit number with a minimum value of 0x0001 (=1/256 g/m³) and a maximum value of 0xFFFF (255 g/m³ + 255/256 g/m³). For instance, sending a value of 0x0F80 corresponds to a humidity value of 15.50 g/m³ (15 g/m³ + 128/256 g/m³).

After setting a new humidity value, this value will be used by the on-chip humidity compensation algorithm until a new humidity value is set using the “sgpc3_set_absolute_humidity” command. Restarting the sensor (power-on or soft reset) or sending a value of 0x0000 (= 0 g/m³) disables the humidity compensation until a new humidity value is sent.

Absolute humidity values d_V in unit g/m³ can be calculated by the following formula:

$$d_V(T, RH) = 216.7 \cdot \left[\frac{\frac{RH}{100\%} \cdot 6.112 \cdot \exp\left(\frac{17.62 \cdot T}{243.12 + T}\right)}{273.15 + T} \right],$$

with temperature T and relative humidity RH .

Example: Inserting $T = 25^\circ\text{C}$ and $RH = 50\%$ in above formula results in the absolute humidity $d_V = 11.8 \text{ g/m}^3$.

⁸ The inceptive baseline feature is available for SGPC3 sensors with feature set 6 and later.

Feature Set

The SGPC3 features a versioning system for the available set of measurement commands and on-chip algorithms. This so called feature set version number can be read out by sending a “sgpc3_get_feature_set_version” command. The sensor responds with 2 data bytes (MSB first) and 1 CRC byte (see **Table 9**). This feature set version number is used to refer to a corresponding set of available measurement commands as listed in **Table 10**.

Most significant byte (MSB)									Least significant byte (LSB)								
Bit	1	2	3	4	5	6	7	8	9	10	11	12	13	14	15	16	
	Product type SGPC3: 1				Reserved for future use				0	Product version							

Table 9 Structure of the SGP feature set number. Please note that the last 5 bits of the product version (bits 12-16 of the LSB) are subject to change. This is used to track new features added to the SGP multi-pixel platform.

Measure Test

The command “sgpc3_measure_test” which is included for integration and production line testing runs an on-chip self-test. In case of a successful self-test the sensor returns the fixed data pattern 0xD400 (with correct CRC).

Feature Set	0x1006			
Command	Hex. Code	Parameter length, including CRC [bytes]	Response length, including CRC [bytes]	Max. measurement duration [ms]
sgpc3_tvoc_init_continuous	0x20ae	-	-	10
sgpc3_measure_tvoc	0x2008	-	3	50
sgpc3_set_power_mode	0x209f	3	-	10
sgpc3_get_tvoc_baseline	0x2015	-	3	10
sgpc3_set_tvoc_baseline	0x201e	3	-	10
sgpc3_set_absolute_humidity	0x2061	3	-	10
sgpc3_measure_test ⁹	0x2032	-	3	220
sgpc3_get_feature_set_version	0x202f	-	3	10
sgpc3_measure_raw	0x204d	-	3	50
sgpc3_measure_tvoc_and_raw	0x2046	-	6	50
sgpc3_get_tvoc_inceptive_baseline	0x20b3	3	3	10

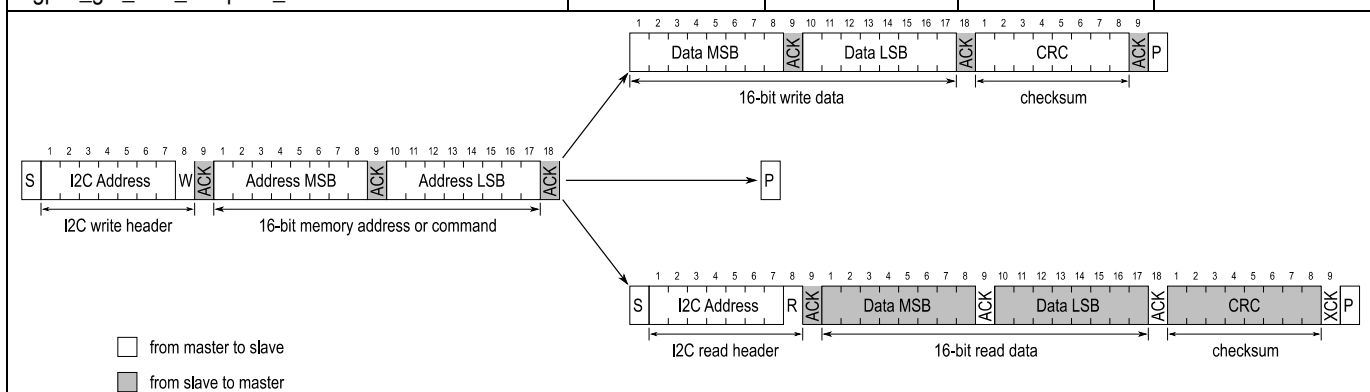

Table 10 Measurement commands.

⁹ The «sgpc3_measure_test» command is intended for production line testing and verification only. It should not be used after having issued an “sgpc3_tvoc_init_continuous” command. For the duration of the « sgpc3_measure_test » command, the sensor is operated in measurement mode with a supply current as specified in **Table 3**. After the command, the sensor is in sleep mode.

6.4 Soft Reset

A sensor reset can be generated using the “General Call” mode according to I²C-bus specification. It is important to understand that a reset generated in this way is not device specific. All devices on the same I²C bus that support the General Call mode will perform a reset. The appropriate command consists of two bytes and is shown in **Table 11**.

Command	Hex. Code
Address byte	0x00
Second byte	0x06
Reset Command using the General Call address	0x0006

Table 11 Reset through the General Call address (Clear blocks are controlled by the microcontroller, grey blocks by the sensor.).

6.5 Get Serial ID

The readout of the serial ID register can be used to identify the chip and verify the presence of the sensor. The appropriate command structure is shown in **Table 12**. After issuing the measurement command and sending the ACK Bit the sensor needs the time $t_{IDLE} = 0.5\text{ms}$ to respond to the I²C read header with an ACK Bit. Hence, it is recommended to wait $t_{IDLE} = 0.5\text{ms}$ before issuing the read header.

The get serial ID command returns 3 words, and every word is followed by an 8-bit CRC checksum. Together the 3 words constitute a unique serial ID with a length of 48 bits.

The ID returned with this command are represented in the big endian (or MSB first) format.

Command	Hex. Code
Get Serial ID	0x3682

Table 12 Get serial ID command.

6.6 Checksum Calculation

The 8-bit CRC checksum transmitted after each data word is generated by a CRC algorithm. Its properties are displayed in **Table 13**. The CRC covers the contents of the two previously transmitted data bytes. To calculate the checksum only these two previously transmitted data bytes are used.

Property	Value
Name	CRC-8
Width	8 bit
Protected Data	read and/or write data
Polynomial	0x31 ($x^8 + x^5 + x^4 + 1$)
Initialization	0xFF
Reflect input	False
Reflect output	False
Final XOR	0x00
Examples	CRC (0xBEEF) = 0x92

Table 13 I²C CRC properties.

6.7 Communication Data Sequences

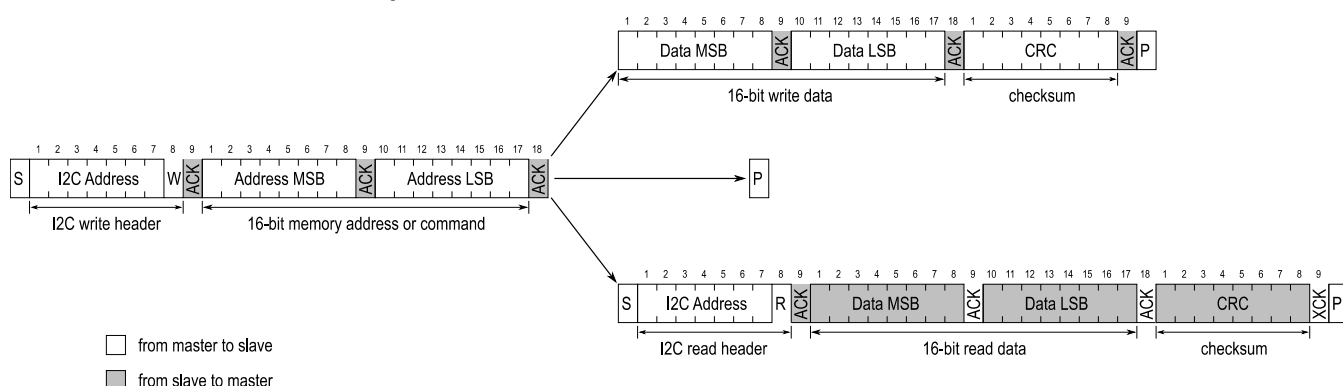

Figure 10 Communication sequence for starting a measurement and reading measurement results.

7 Quality

7.1 Environmental Stability

The qualification of the SGPC3 was performed based on the JEDEC JESD47 qualification test method.

7.2 Material Contents

The device is fully RoHS and WEEE compliant, e.g., free of Pb, Cd, and Hg.

8 Device Package

SGPC3 sensors are provided in a DFN (dual flat no leads) package with an outline of $2.45 \times 2.45 \times 0.9 \text{ mm}^3$ and a terminal pitch of 0.8 mm. The circular sensor opening of maximally 1.6 mm diameter is centered on the top side of the package. The sensor chip is assembled on a Ni/Pd/Au plated copper lead frame. Sensor chip and lead frame are over-molded by a black, epoxy-based mold compound. Please note that the side walls of the package are diced and therefore the lead frame sidewall surfaces are not plated. SGPC3

8.1 Moisture Sensitivity Level

The Moisture Sensitivity Level classification of the SGPC3 is MSL1, according to IPC/JEDEC J-STD-020.

8.2 Traceability

All SGPC3 sensors are laser marked for simple identification and traceability. The marking on the sensor consists of the product name and a 4-digit, alphanumeric tracking code. This code is used by Sensirion for batch-level tracking throughout production, calibration, and testing. Detailed tracking data can be provided upon justified request. The pin-1 location is indicated by the keyhole pattern in the light-colored central area. See **Figure 11** for illustration.

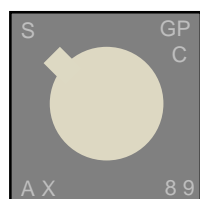

Figure 11 Laser marking on SGPC3. The pin-1 location is indicated by the keyhole pattern in the light-colored central area. The bottom line contains a 4-digit alphanumeric tracking code

8.3 Package Outline

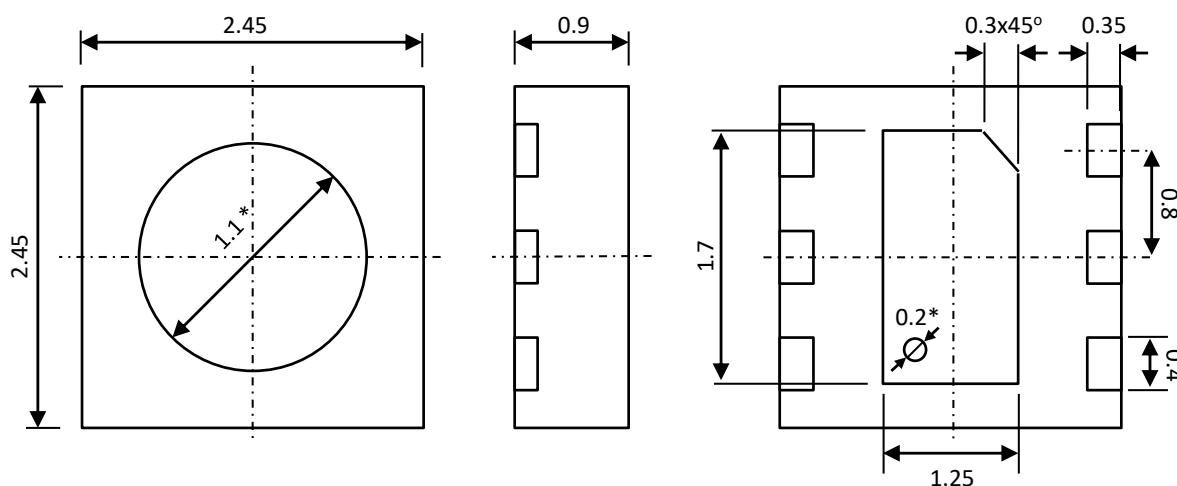

Figure 12 Package outlines drawing of the SGPC3 with nominal values. Dimensions are given in millimeters. * The die pad shows a small recess in the bottom left part. * These dimensions are not well defined and given as a reference only.

8.4 Landing Pattern

Figure 13 shows the PCB landing pattern. The landing pattern is understood to be the metal layer on the PCB, onto which the DFN pads are soldered. The solder mask is understood to be the insulating layer on top of the PCB covering the copper traces. It is recommended to design the solder mask as a Non-Solder Mask Defined (NSMD) type. For solder paste printing it is recommended to use a laser-cut, stainless steel stencil with electro-polished trapezoidal walls and with 0.125 to 0.150 mm stencil thickness. The length of the stencil apertures for the I/O pads should be the same as the PCB pads. However, the position of the stencil apertures should have an offset of 0.1 mm away from the package center, as indicated in **Figure 13**. The die pad aperture should cover 70 – 90 % of the die pad area, resulting in a size of about 1.05 mm x 1.5 mm.

For information on the soldering process and further recommendation on the assembly process please contact Sensirion.

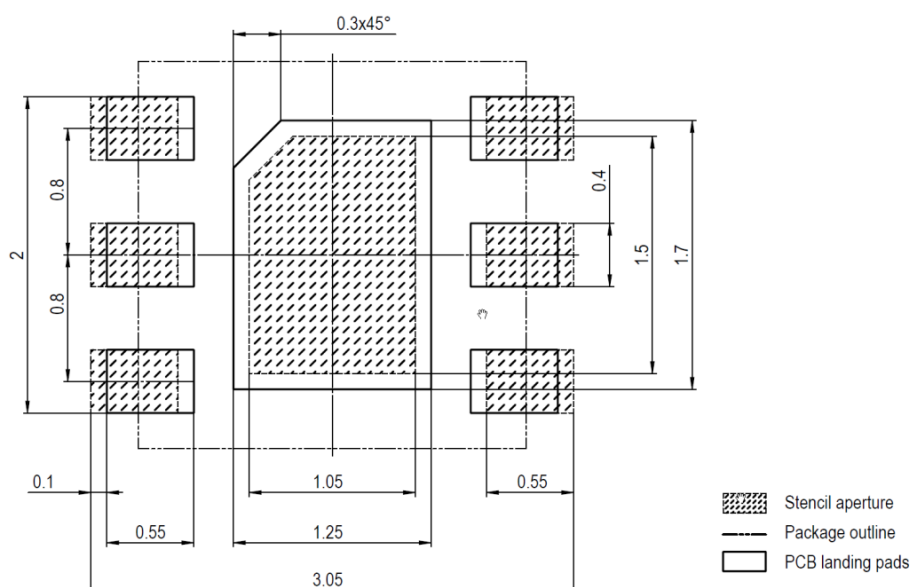

Figure 13 Recommended landing pattern.

8.5 Soldering Instructions

Standard reflow soldering ovens may be used for soldering. The sensors are designed to withstand a soldering profile according to IPC/JEDEC J-STD-020. Peak temperatures of $T_P = 245\text{ °C}$ during up to $t_P = 30$ seconds for Pb-free assembly in IR/Convection reflow ovens (see **Figure 14**) are recommended. In addition, we also recommend a maximum ramp-down rate of $< 4\text{ °C/s}$.

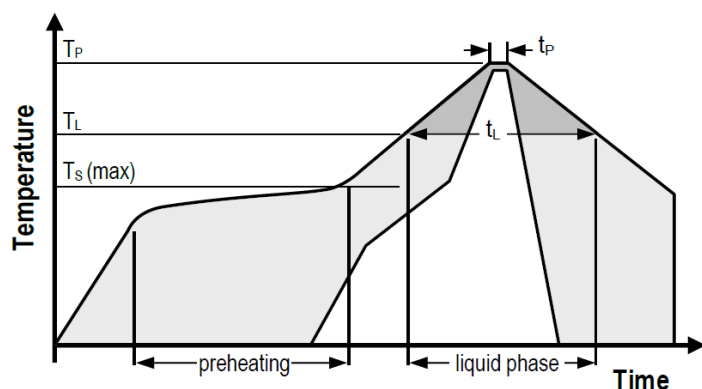

Figure 14 Soldering profile according to JEDEC standard. Recommended conditions are $T_P = 245\text{ °C}$ and $t_P \leq 30$ sec for Pb-free assembly, $T_L < 220\text{ °C}$ and $t_L < 150$ s. Ramp-up rate $< 3\text{ °C/s}$ and ramp-down rate $< 4\text{ °C/s}$.

It is recommended not to use vapor phase soldering to avoid potential contamination of the sensor. Please refer to Handling and Assembly Guideline for Sensirion Gas Sensors on Sensirion webpage for full documentation.

9 Tape & Reel Package

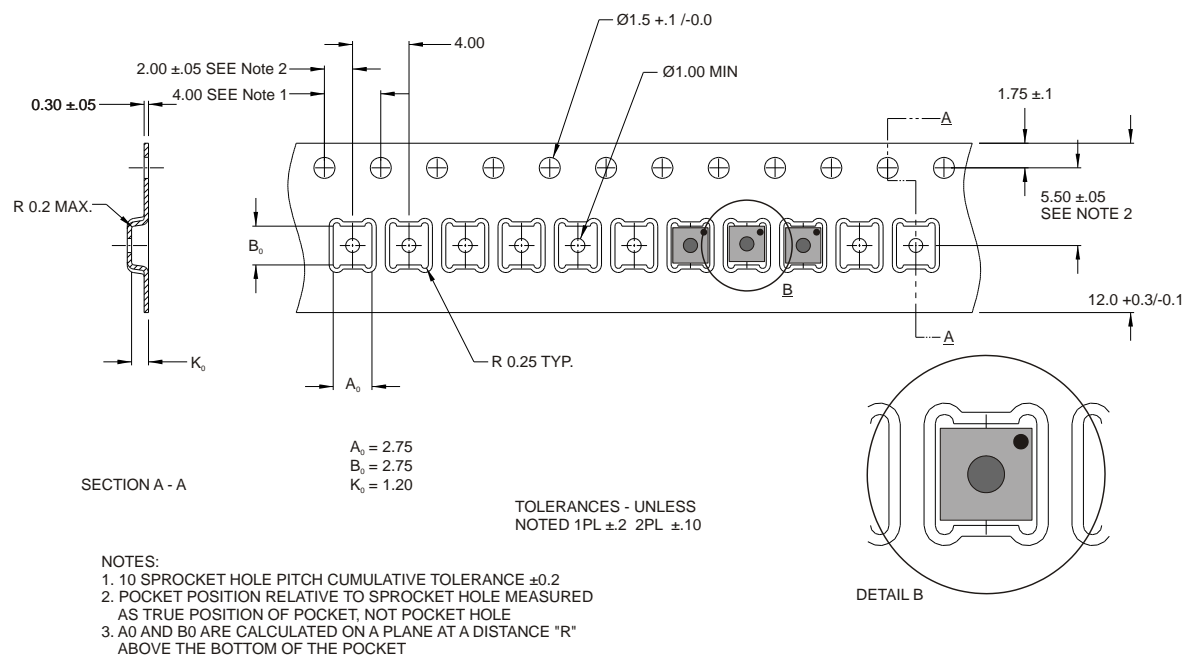

Figure 15 Technical drawing of the packaging tape with sensor orientation in tape. Header tape is to the right and trailer tape to the left on this drawing. Dimensions are given in millimeters.

10 Ordering Information

Use the part names and product numbers shown in the following table when ordering the SGPC3 multi-pixel gas sensor. For the latest product information and local distributors, visit www.sensirion.com.

Part Name	Tape & Reel Size	Product Number
SGPC3, TAPE ON REEL, 2500 PCS	2500	1-101647-01

Table 14 SGPC3 ordering options

Revision History

Date	Version	Page(s)	Changes
May, 2020	1.0	–	–

Important Notices

Warning, Personal Injury

Do not use this product as safety or emergency stop devices or in any other application where failure of the product could result in personal injury. Do not use this product for applications other than its intended and authorized use. Before installing, handling, using or servicing this product, please consult the data sheet and application notes. Failure to comply with these instructions could result in death or serious injury.

If the Buyer shall purchase or use SENSIRION products for any unintended or unauthorized application, Buyer shall defend, indemnify and hold harmless SENSIRION and its officers, employees, subsidiaries, affiliates and distributors against all claims, costs, damages and expenses, and reasonable attorney fees arising out of, directly or indirectly, any claim of personal injury or death associated with such unintended or unauthorized use, even if SENSIRION shall be allegedly negligent with respect to the design or the manufacture of the product.

ESD Precautions

The inherent design of this component causes it to be sensitive to electrostatic discharge (ESD). To prevent ESD-induced damage and/or degradation, take customary and statutory ESD precautions when handling this product. See application note "ESD, Latchup and EMC" for more information.

Warranty

SENSIRION warrants solely to the original purchaser of this product for a period of 12 months (one year) from the date of delivery that this product shall be of the quality, material and workmanship defined in SENSIRION's published specifications of the product. Within such period, if proven to be defective, SENSIRION shall repair and/or replace this product, in SENSIRION's discretion, free of charge to the Buyer, provided that:

- notice in writing describing the defects shall be given to SENSIRION within fourteen (14) days after their appearance;
- such defects shall be found, to SENSIRION's reasonable satisfaction, to have arisen from SENSIRION's faulty design, material, or workmanship;
- the defective product shall be returned to SENSIRION's factory at the Buyer's expense; and
- the warranty period for any repaired or replaced product shall be limited to the unexpired portion of the original period.

This warranty does not apply to any equipment which has not been installed and used within the specifications recommended by SENSIRION for the intended and proper use of the equipment. EXCEPT FOR THE WARRANTIES EXPRESSLY SET FORTH HEREIN, SENSIRION MAKES NO WARRANTIES, EITHER EXPRESS OR IMPLIED, WITH RESPECT TO THE PRODUCT. ANY AND ALL WARRANTIES, INCLUDING WITHOUT LIMITATION, WARRANTIES OF MERCHANTABILITY OR FITNESS FOR A PARTICULAR PURPOSE, ARE EXPRESSLY EXCLUDED AND DECLINED. SENSIRION is only liable for defects of this product arising under the conditions of operation provided for in the data sheet and proper use of the goods. SENSIRION explicitly disclaims all warranties, express or implied, for any period during which the goods are operated or stored not in accordance with the technical specifications.

SENSIRION does not assume any liability arising out of any application or use of any product or circuit and specifically disclaims any and all liability, including without limitation consequential or incidental damages. All operating parameters, including without limitation recommended parameters, must be validated for each customer's applications by customer's technical experts. Recommended parameters can and do vary in different applications. SENSIRION reserves the right, without further notice, (i) to change the product specifications and/or the information in this document and (ii) to improve reliability, functions and design of this product.

Copyright © 2020 by SENSIRION.

CMOSens® is a trademark of Sensirion.

All rights reserved.

Headquarters and Subsidiaries

Sensirion AG

Laubisruetistr. 50
CH-8712 Staefa ZH
Switzerland

phone: +41 44 306 40 00
fax: +41 44 306 40 30
info@sensirion.com
www.sensirion.com

Sensirion Taiwan Co. Ltd

phone: +886 3 5506701
info@sensirion.com
www.sensirion.com

Sensirion Inc., USA

phone: +1 312 690 5858
info-us@sensirion.com
www.sensirion.com

Sensirion Japan Co. Ltd.

phone: +81 3 3444 4940
info-jp@sensirion.com
www.sensirion.com/jp

Sensirion Korea Co. Ltd.

phone: +82 31 337 7700~3
info-kr@sensirion.com
www.sensirion.com/kr

Sensirion China Co. Ltd.

phone: +86 755 8252 1501
info-cn@sensirion.com
www.sensirion.com/cn

To find your local representative, please visit www.sensirion.com/distributors



Компания «ЭлектроПласт» предлагает заключение долгосрочных отношений при поставках импортных электронных компонентов на взаимовыгодных условиях!

Наши преимущества:

- Оперативные поставки широкого спектра электронных компонентов отечественного и импортного производства напрямую от производителей и с крупнейших мировых складов;
- Поставка более 17-ти миллионов наименований электронных компонентов;
- Поставка сложных, дефицитных, либо снятых с производства позиций;
- Оперативные сроки поставки под заказ (от 5 рабочих дней);
- Экспресс доставка в любую точку России;
- Техническая поддержка проекта, помощь в подборе аналогов, поставка прототипов;
- Система менеджмента качества сертифицирована по Международному стандарту ISO 9001;
- Лицензия ФСБ на осуществление работ с использованием сведений, составляющих государственную тайну;
- Поставка специализированных компонентов (Xilinx, Altera, Analog Devices, Intersil, Interpoint, Microsemi, Aeroflex, Peregrine, Syfer, Eurofarad, Texas Instrument, Miteq, Cobham, E2V, MA-COM, Hittite, Mini-Circuits, General Dynamics и др.);

Помимо этого, одним из направлений компании «ЭлектроПласт» является направление «Источники питания». Мы предлагаем Вам помощь Конструкторского отдела:

- Подбор оптимального решения, техническое обоснование при выборе компонента;
- Подбор аналогов;
- Консультации по применению компонента;
- Поставка образцов и прототипов;
- Техническая поддержка проекта;
- Защита от снятия компонента с производства.



Как с нами связаться

Телефон: 8 (812) 309 58 32 (многоканальный)

Факс: 8 (812) 320-02-42

Электронная почта: org@eplast1.ru

Адрес: 198099, г. Санкт-Петербург, ул. Калинина, дом 2, корпус 4, литера А.