

LITIX™ Basic

TLD1124EL

1 Channel High-Side Current Source



Package	PG-SSOP-14
Marking	TLD1124

1 Overview

Applications

- Exterior LED lighting applications such as tail/brake light, turn indicator, position light, side marker,...
- Interior LED lighting applications such as ambient lighting, interior illumination and dash board lighting.

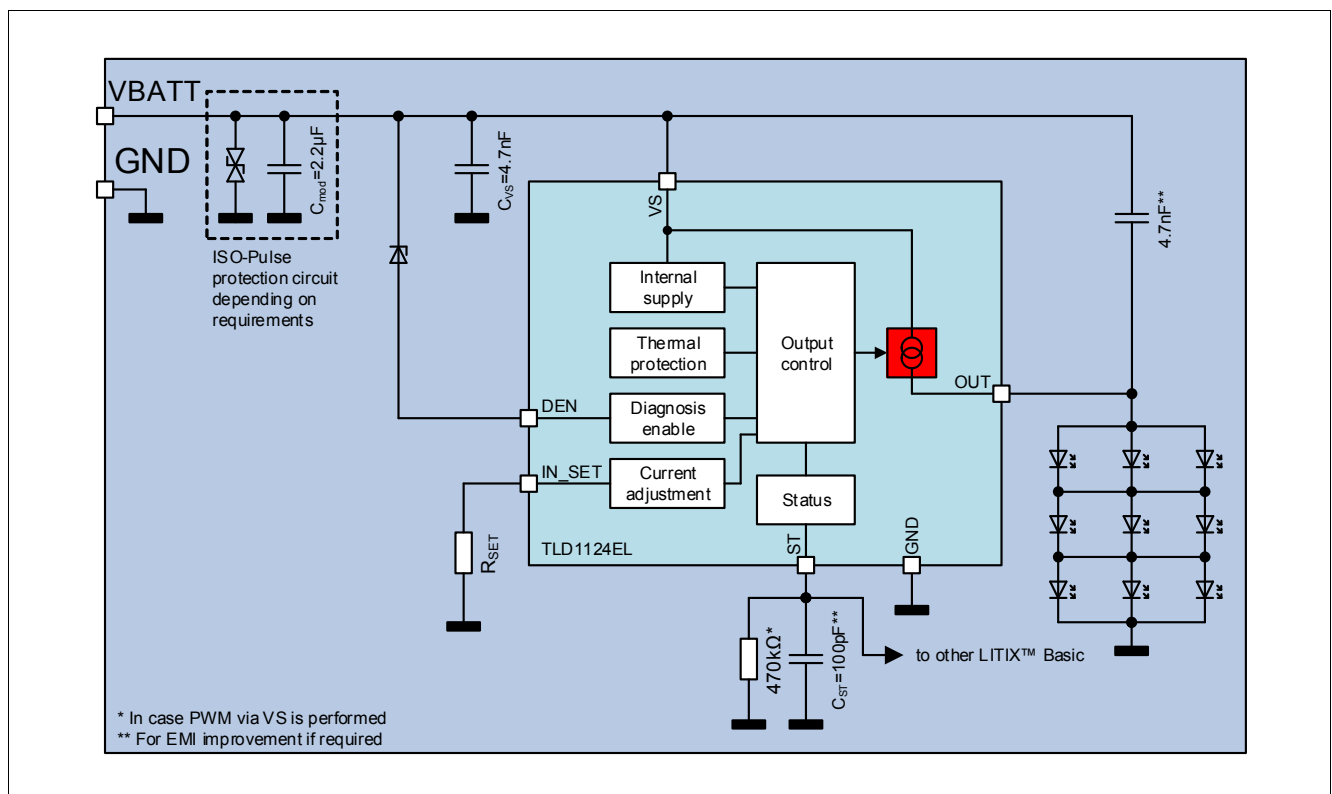
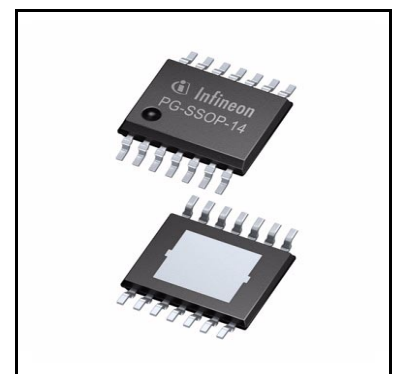

Application Diagram with TLD1124EL

Overview

Basic Features

- 1 Channel device with integrated output stage (current source), optimized to drive LEDs with output current up to 360 mA
- Low current consumption
- PWM-operation supported via VS-pin
- Output current adjustable via external low power resistor and possibility to connect PTC resistor for LED protection during over temperature conditions
- Reverse polarity protection and overload protection
- Undervoltage detection
- Open load and short circuit to GND diagnosis
- Wide temperature range: $-40^{\circ}\text{C} < T_j < 150^{\circ}\text{C}$
- PG-SSOP-14 package with exposed heatslug

Description

The LITIX™ Basic TLD1124EL is a one channel high side driver IC with integrated output stage. It is designed to control LEDs with a current up to 360 mA. In typical automotive applications the device is capable to drive i.e. 3 red LEDs with a current up to 180 mA, which is limited by thermal cooling aspects. The output current is controlled practically independent of load and supply voltage changes.

Table 1 Product Summary

Parameter	Symbol	Value
Operating voltage range	$V_{S(nom)}$	5.5 V ... 40 V
Maximum voltage	$V_{S(max)}$ $V_{OUT(max)}$	40 V
Nominal output (load) current	$I_{OUT(nom)}$	180 mA when using a supply voltage range of 8 V - 18 V (e.g. Automotive car battery). Currents up to $I_{OUT(max)}$ possible in applications with low thermal resistance R_{thJA}
Maximum output (load) current	$I_{OUT(max)}$	360 mA; depending on thermal resistance R_{thJA}
Output current accuracy at $R_{SET} = 12 \text{ k}\Omega$	k_{LT}	$2250 \pm 7\%$

Protective Functions

- ESD protection
- Under voltage lock out
- Over Load protection
- Over Temperature protection
- Reverse Polarity protection

Diagnostic Functions

- Diagnosis enable function
- OL detection
- SC to Vs (indicated by OL diagnosis)
- SC to GND detection

Block Diagram

2 Block Diagram

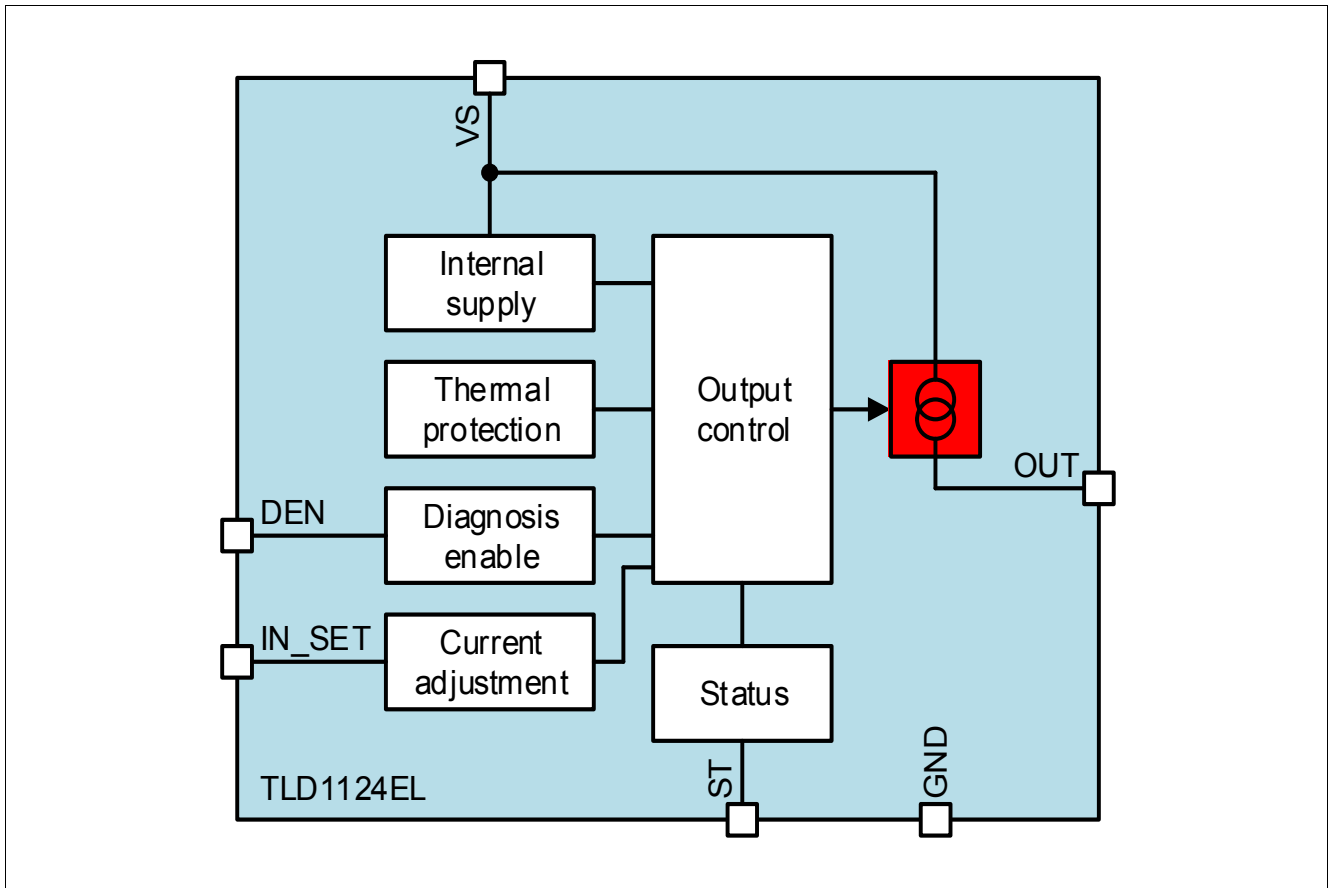

Figure 1 Basic Block Diagram

Pin Configuration

3 Pin Configuration

3.1 Pin Assignment

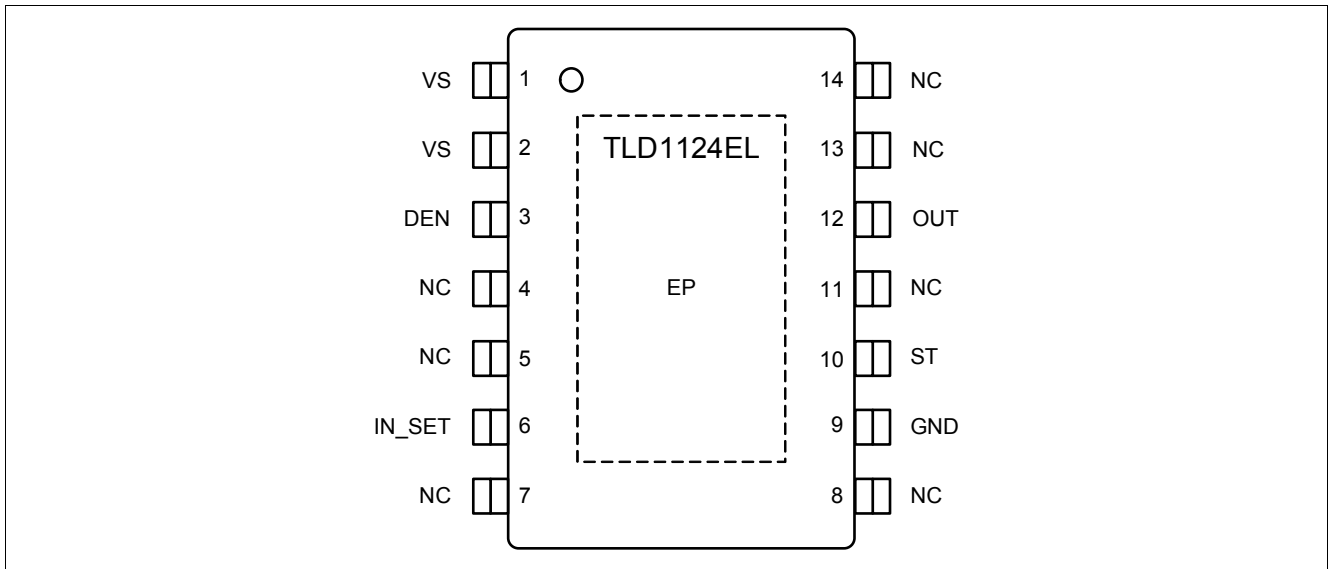

Figure 2 Pin Configuration

Pin Configuration

3.2 Pin Definitions and Functions

Pin	Symbol	Input/ Output	Function
1, 2	VS	–	Supply Voltage; battery supply, connect a decoupling capacitor (100 nF - 1 μF) to GND
3	DEN	I	Diagnosis enable pin
4	NC	–	Pin not connected
5	NC	–	Pin not connected
6	IN_SET	I/O	Input / SET pin; Connect a low power resistor to adjust the output current
7	NC	–	Pin not connected
8	NC	–	Pin not connected
9	GND	–	¹⁾ Ground
10	ST	I/O	Status pin
11	NC	–	Pin not connected
12	OUT	O	Output
13	NC	–	Pin not connected
14	NC	–	Pin not connected
Exposed Pad	GND	–	¹⁾ Exposed Pad; connect to GND in application

1) Connect all GND-pins together.

General Product Characteristics

4 General Product Characteristics

4.1 Absolute Maximum Ratings

Absolute Maximum Ratings ¹⁾

$T_j = -40^\circ\text{C}$ to $+150^\circ\text{C}$; all voltages with respect to ground, positive current flowing into pin for input pins (I), positive currents flowing out of the I/O and output pins (O) (unless otherwise specified)

Pos.	Parameter	Symbol	Limit Values		Unit	Conditions
			Min.	Max.		
Voltages						
4.1.1	Supply voltage	V_S	-16	40	V	-
4.1.2	Diagnosis enable voltage DEN	V_{DEN}	-16	40	V	-
4.1.3	Diagn. enable voltage DEN related to V_S	$V_{DEN(VS)}$	$V_S - 40$	$V_S + 16$	V	-
4.1.4	Diagn. enable voltage DEN related to V_{OUT}	$V_{DEN} - V_{OUT}$	-16	40	V	-
4.1.5	Output voltage	V_{OUT}	-1	40	V	-
4.1.6	Power stage voltage $V_{PS} = V_S - V_{OUT}$	V_{PS}	-16	40	V	-
4.1.7	IN_SET voltage	V_{IN_SET}	-0.3	6	V	-
4.1.8	Status voltage	V_{ST}	-0.3	6	V	-
Currents						
4.1.9	IN_SET current	I_{IN_SET}	-	2 8	mA	- Diagnosis output
4.1.10	Output current	I_{OUT}	-	390	mA	-
Temperatures						
4.1.11	Junction temperature	T_j	-40	150	°C	-
4.1.12	Storage temperature	T_{stg}	-55	150	°C	-
ESD Susceptibility						
4.1.13	ESD resistivity to GND	V_{ESD}	-2	2	kV	Human Body Model (100 pF via 1.5 kΩ) ²⁾
4.1.14	ESD resistivity all pins to GND	V_{ESD}	-500	500	V	CDM ³⁾
4.1.15	ESD resistivity corner pins to GND	V_{ESD}	-750	750	V	CDM ³⁾

1) Not subject to production test, specified by design

2) ESD susceptibility, Human Body Model "HBM" according to ANSI/ESDA/JEDEC JS-001-2011

3) ESD susceptibility, Charged Device Model "CDM" according to JESD22-C101E

Note: Stresses above the ones listed here may cause permanent damage to the device. Exposure to absolute maximum rating conditions for extended periods may affect device reliability.

Note: Integrated protection functions are designed to prevent IC destruction under fault conditions described in the data sheet. Fault conditions are considered as "outside" normal operating range. Protection functions are not designed for continuous repetitive operation.

General Product Characteristics

4.2 Functional Range

Pos.	Parameter	Symbol	Limit Values		Unit	Conditions
			Min.	Max.		
4.2.16	Supply voltage range for normal operation	$V_{S(nom)}$	5.5	40	V	–
4.2.17	Power on reset threshold	$V_{S(POR)}$	–	5	V	$R_{SET} = 12\text{ k}\Omega$ $I_{OUT} = 80\% I_{OUT(nom)}$ $V_{OUT} = 2.5\text{ V}$
4.2.18	Junction temperature	T_j	-40	150	°C	–

Note: Within the functional range the IC operates as described in the circuit description. The electrical characteristics are specified within the conditions given in the related electrical characteristics table.

4.3 Thermal Resistance

Pos.	Parameter	Symbol	Limit Values			Unit	Conditions
			Min.	Typ.	Max.		
4.3.1	Junction to Case	R_{thJC}	–	8	10	K/W	^{1) 2)}
4.3.2	Junction to Ambient 1s0p board	R_{thJA1}	–	61	–	K/W	^{1) 3)} $T_a = 85\text{ °C}$ $T_a = 135\text{ °C}$
4.3.3	Junction to Ambient 2s2p board	R_{thJA2}	–	45	–	K/W	^{1) 4)} $T_a = 85\text{ °C}$ $T_a = 135\text{ °C}$

- 1) Not subject to production test, specified by design. Based on simulation results.
- 2) Specified R_{thJC} value is simulated at natural convection on a cold plate setup (all pins and the exposed Pad are fixed to ambient temperature). $T_a = 85\text{ °C}$, Total power dissipation 1.5 W.
- 3) The R_{thJA} values are according to Jedec JESD51-3 at natural convection on 1s0p FR4 board. The product (chip + package) was simulated on a 76.2 x 114.3 x 1.5 mm³ board with 70 μm Cu, 300 mm² cooling area. Total power dissipation 1.5 W distributed statically and homogeneously over power stage.
- 4) The R_{thJA} values are according to Jedec JESD51-5,-7 at natural convection on 2s2p FR4 board. The product (chip + package) was simulated on a 76.2 x 114.3 x 1.5 mm³ board with 2 inner copper layers (outside 2 x 70 μm Cu, inner 2 x 35 μm Cu). Where applicable, a thermal via array under the exposed pad contacted the first inner copper layer. Total power dissipation 1.5 W distributed statically and homogeneously over power stage.

DEN Pin

5 DEN Pin

The DEN pin is a single function pin:

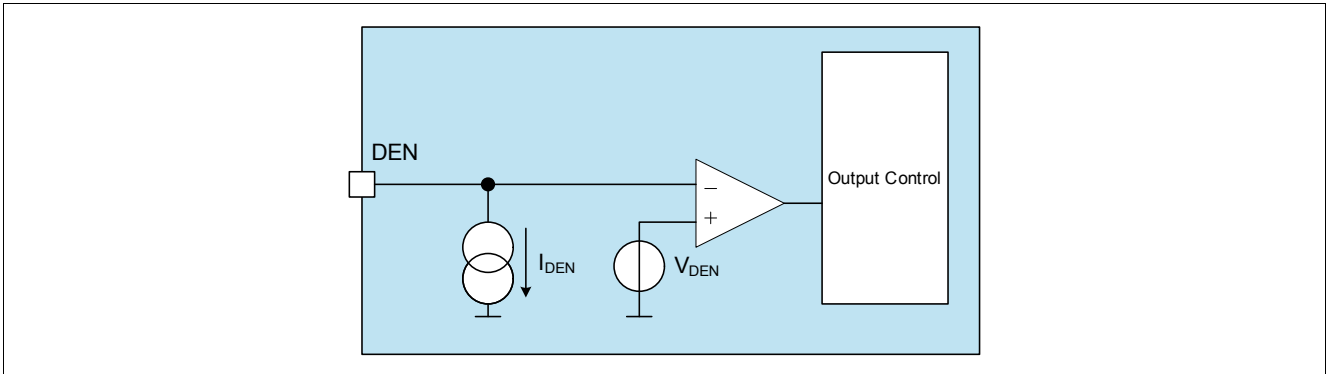

Figure 3 Block Diagram DEN pin

This pin is used to activate or deactivate the device internal diagnosis functions. The diagnostic functions are described in [Chapter 6.2](#), [Chapter 7](#) and [Chapter 8](#). The diagnosis is activated, if the voltage applied at the DEN pin V_{DEN} is higher than $V_{DEN(act)}$. The diagnosis is disabled for voltages below $V_{DEN(dis)}$.

A possibility to use the DEN pin is via a Zener diode, which is connected between V_S and DEN pin. A circuit example is shown in the application information section [Chapter 10](#).

The diagnosis is activated, if the following condition is fulfilled:

$$V_S \geq V_{DEN(act)} + V_{ZD} \tag{1}$$

The current consumption on the DEN pin has to be considered for the total device current consumption. The current is specified in [Pos. 5.1.8](#). The typical current consumption $I_{DEN(H)}$ as a function of the supply voltage V_S for a Zener diode voltage of $V_{ZD} = 6\text{ V}$ is shown in the following diagram.

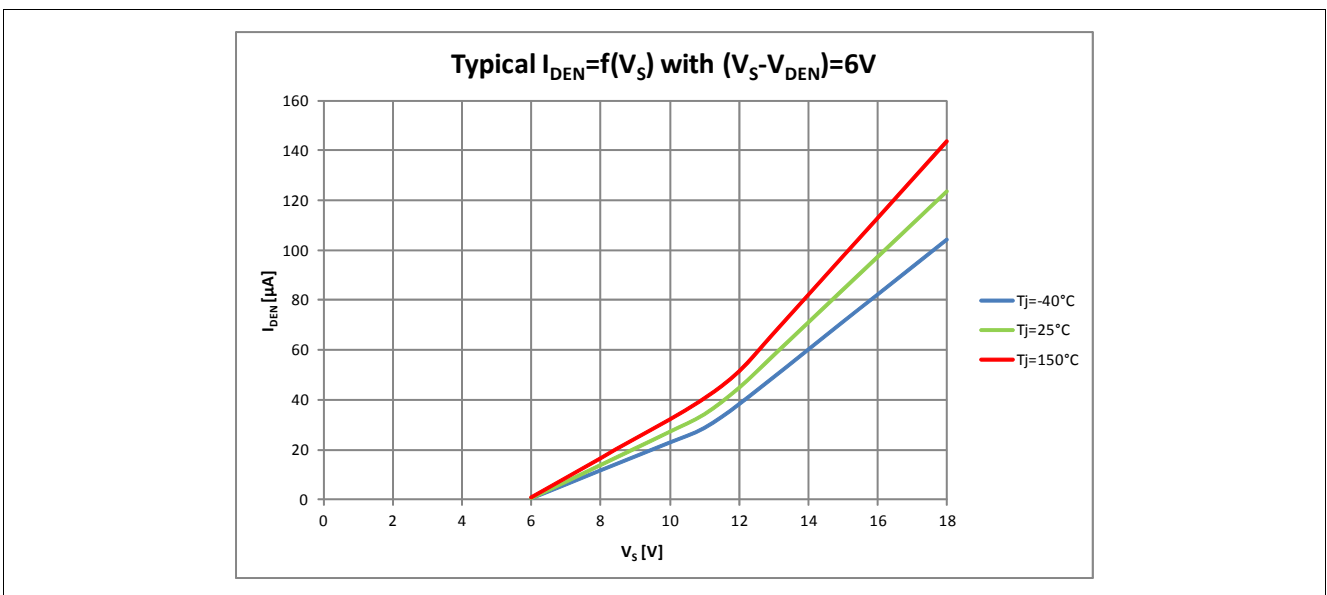

Figure 4 Typical $I_{DEN(H)}$ current for a Zener diode voltage of 6 V

The device and channel turn on is independent of the V_{DEN} -voltage. After applying a supply voltage the device is activated after the power on reset time t_{POR} .

DEN Pin

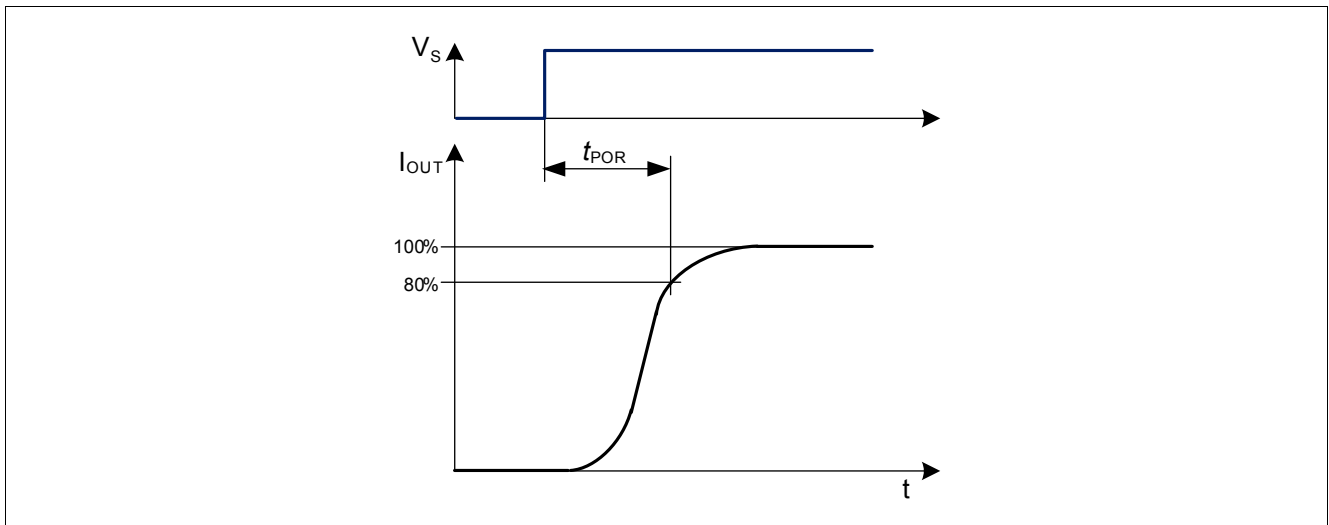

Figure 5 Power on reset

The DEN voltage V_{DEN} does not influence the disable function via the ST pin. If $V_{DEN} < V_{DEN(dis)}$ the device can still be disabled via the ST pin, if $V_{ST} > V_{ST(H)}$. For details, please refer to [Chapter 7.3](#).

5.1 Electrical Characteristics Internal Supply / DEN Pin

Electrical Characteristics Internal Supply / DEN pin

Unless otherwise specified: $V_S = 5.5\text{ V to }40\text{ V}$, $T_j = -40^\circ\text{C to }+150^\circ\text{C}$, $R_{SET} = 12\text{ k}\Omega$ all voltages with respect to ground, positive current flowing into pin for input pins (I), positive currents flowing out of the I/O and output pins (O) (unless otherwise specified)

Pos.	Parameter	Symbol	Limit Values			Unit	Conditions
			Min.	Typ.	Max.		
5.1.1	Current consumption, active mode	$I_{S(on)}$	–	–	1.9	mA	¹⁾ $I_{IN_SET} = 0\ \mu\text{A}$ $T_j < 105^\circ\text{C}$ $V_S = 18\text{ V}$ $V_{OUT} = 3.6\text{ V}$
5.1.2	Current consumption, device disabled via ST	$I_{S(dis,ST)}$	–	–	1.7	mA	¹⁾ $V_S = 18\text{ V}$ $T_j < 105^\circ\text{C}$ $V_{ST} = 5\text{ V}$
5.1.3	Current consumption, device disabled via IN_SET	$I_{S(dis,IN_SET)}$	–	–	1.7	mA	¹⁾ $V_S = 18\text{ V}$ $T_j < 105^\circ\text{C}$ $V_{IN_SET} = 5\text{ V}$
5.1.4	Current consumption, active mode in fault detection condition with ST-pin unconnected	$I_{S(fault,STu)}$	–	–	2.1	mA	¹⁾ $V_S = 18\text{ V}$ $T_j < 105^\circ\text{C}$ $R_{SET} = 12\text{ k}\Omega$ $V_{OUT} = 18\text{ V or }0\text{ V}$
5.1.5	Current consumption, active mode in fault detection condition with ST-pin connected to GND	$I_{S(fault,STG)}$	–	–	6.2	mA	¹⁾ $V_S = 18\text{ V}$ $T_j < 105^\circ\text{C}$ $R_{SET} = 12\text{ k}\Omega$ $V_{OUT} = 18\text{ V or }0\text{ V}$ $V_{ST} = 0\text{ V}$

DEN Pin

Electrical Characteristics Internal Supply / DEN pin (cont'd)

Unless otherwise specified: $V_S = 5.5\text{ V to }40\text{ V}$, $T_J = -40^\circ\text{C to }+150^\circ\text{C}$, $R_{SET} = 12\text{ k}\Omega$ all voltages with respect to ground, positive current flowing into pin for input pins (I), positive currents flowing out of the I/O and output pins (O) (unless otherwise specified)

Pos.	Parameter	Symbol	Limit Values			Unit	Conditions
			Min.	Typ.	Max.		
5.1.6	Power-on reset delay time ²⁾	t_{POR}	-	-	25	μs	³⁾ $V_S = 0 \rightarrow 13.5\text{ V}$ $V_{OUT(nom)} = 3.6 \pm 0.3\text{ V}$ $I_{OUT} = 80\% I_{OUT(nom)}$
5.1.7	Required supply voltage for current control	$V_{S(CC)}$	-	-	5.5	V	$V_{OUT} = 3.6\text{ V}$ $I_{OUT} \geq 90\% I_{OUT(nom)}$
5.1.8	DEN high input current	$I_{DEN(H)}$	-	-	0.1 0.1 0.2 0.4	mA	$T_J < 105^\circ\text{C}$ $V_S = 13.5\text{ V}, V_{DEN} = 5.5\text{ V}$ $V_S = 18\text{ V}, V_{DEN} = 5.5\text{ V}$ $V_S = 18\text{ V}, V_{DEN} = 12\text{ V}$ $V_S = V_{DEN} = 18\text{ V}$
5.1.9	DEN activation threshold (diagnosis enabled above $V_{DEN(act)}$)	$V_{DEN(act)}$	2.45	-	3.2	V	$V_S = 8...18\text{ V}$
5.1.10	DEN deactivation threshold (diagnosis disabled below $V_{DEN(dis)}$)	$V_{DEN(dis)}$	1.5	-	2.3	V	$V_S = 8...18\text{ V}$

- 1) The total device current consumption is the sum of the currents I_S and $I_{DEN(H)}$, please refer to **Pos. 5.1.8**
- 2) See also **Figure 4**
- 3) Not subject to production test, specified by design

IN_SET Pin

6 IN_SET Pin

The IN_SET pin is a multiple function pin for output current definition, input and diagnostics:

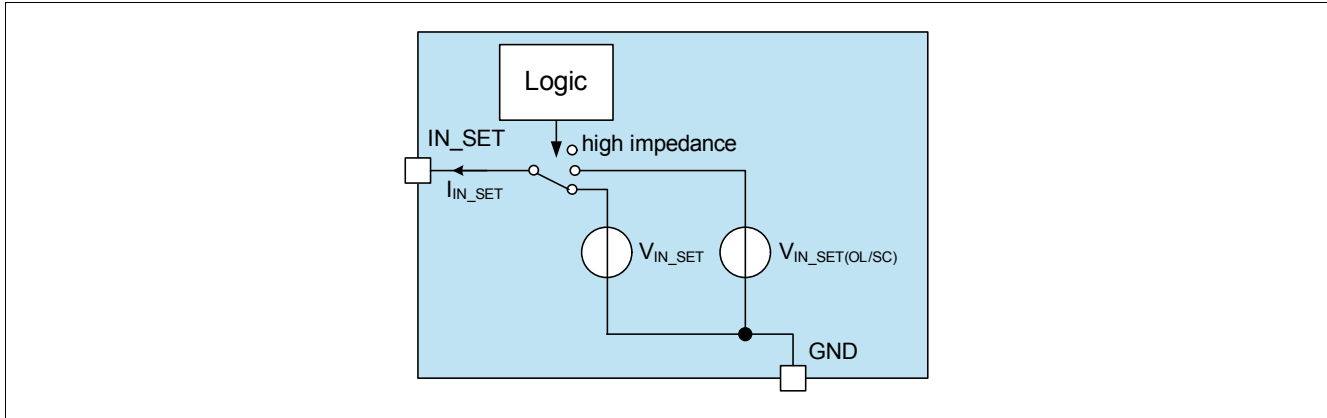

Figure 6 Block Diagram IN_SET pin

6.1 Output Current Adjustment via RSET

The current adjustment can be done by placing a low power resistor (R_{SET}) at the IN_SET pin to ground. The dimensioning of the resistor can be done using the formula below:

$$R_{SET} = \frac{k}{I_{OUT}} \quad (2)$$

The gain factor k (R_{SET} * output current) is specified in [Pos. 9.2.4](#) and [Pos. 9.2.5](#). The current through the R_{SET} is defined by the resistor itself and the reference voltage $V_{IN_SET(ref)}$, which is applied to the IN_SET during supplied device.

6.2 Smart Input Pin

The IN_SET pin can be connected via R_{SET} to the open-drain output of a μC or to an external NMOS transistor as described in [Figure 7](#). This signal can be used to turn off the output stage of the IC. A minimum IN_SET current of $I_{IN_SET(act)}$ is required to turn on the output stage. This feature is implemented to prevent glimming of LEDs caused by leakage currents on the IN_SET pin, see [Figure 10](#) for details. In addition, the IN_SET pin offers the diagnostic feedback information, if the status pin is connected to GND and $V_{DEN} > V_{DEN(act)}$ (refer to [Chapter 5](#)). Another diagnostic possibility is shown in [Figure 8](#), where the diagnosis information is provided via the ST pin (refer to [Chapter 7](#) and [Chapter 8](#)) to a micro controller. In case of a fault event with the ST pin connected to GND the IN_SET voltage is increased to $V_{IN_SET(OL/SC)}$ [Pos. 8.3.2](#). Therefore, the device has two voltage domains at the IN_SET-pin, which is shown in [Figure 11](#).

IN_SET Pin

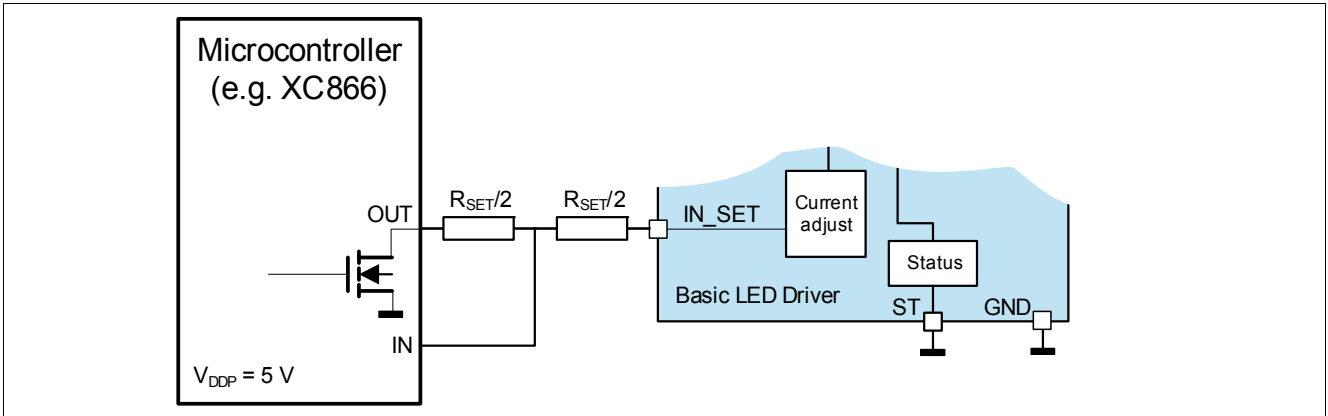

Figure 7 Schematics IN_SET interface to μ C, diagnosis via IN_SET pin

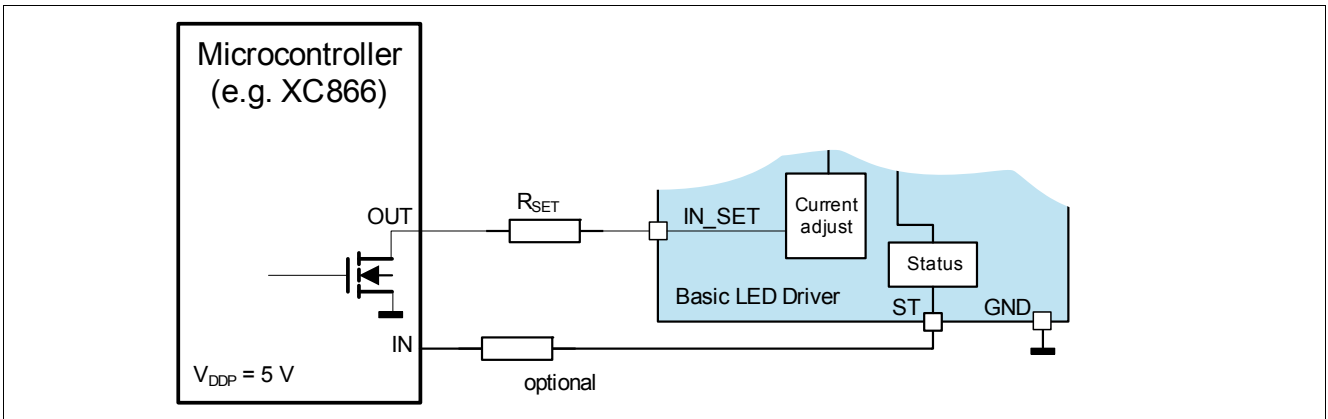

Figure 8 Schematics IN_SET interface to μ C, diagnosis via ST pin

The resulting switching times are shown in [Figure 9](#):

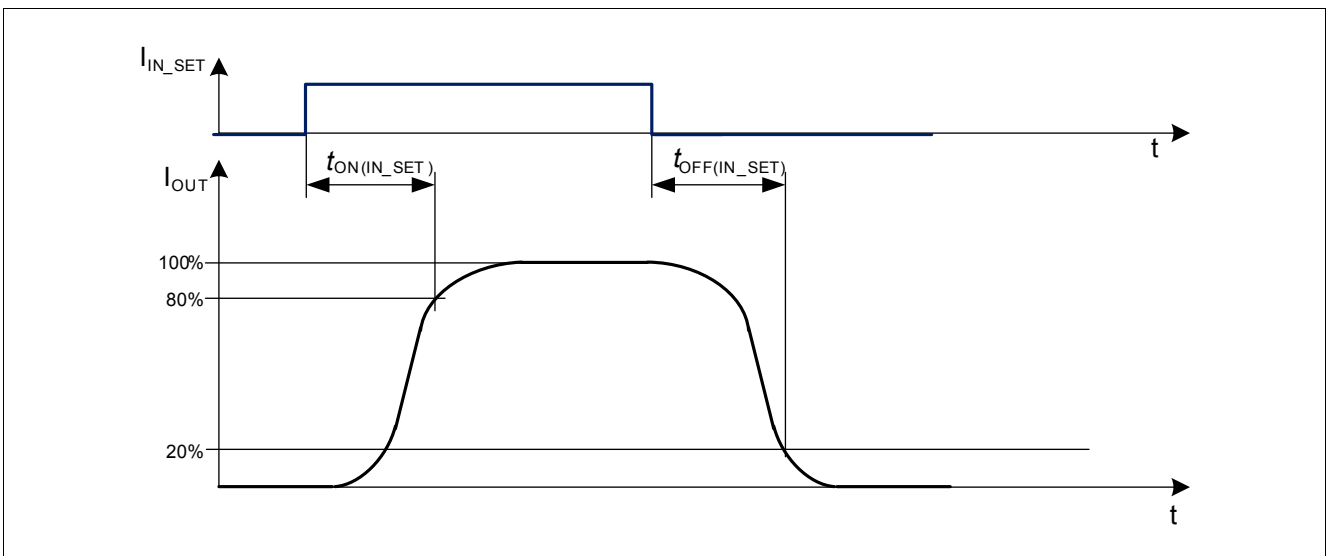

Figure 9 Switching times via IN_SET

IN_SET Pin

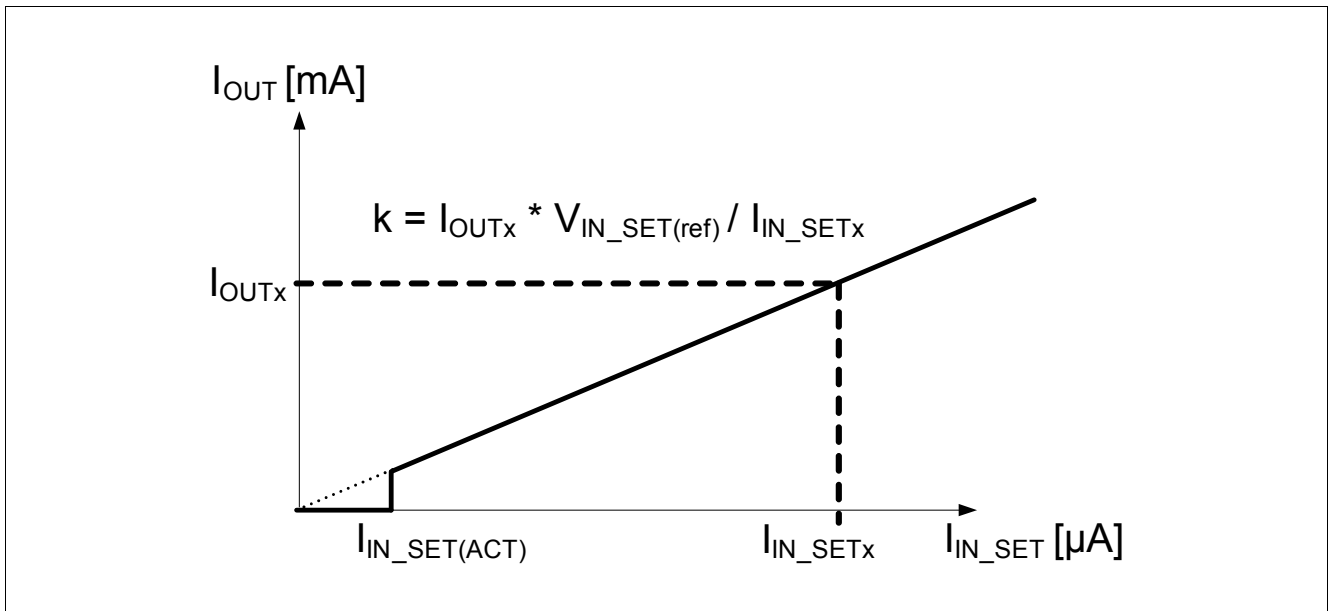

Figure 10 I_{OUT} versus I_{INSET}

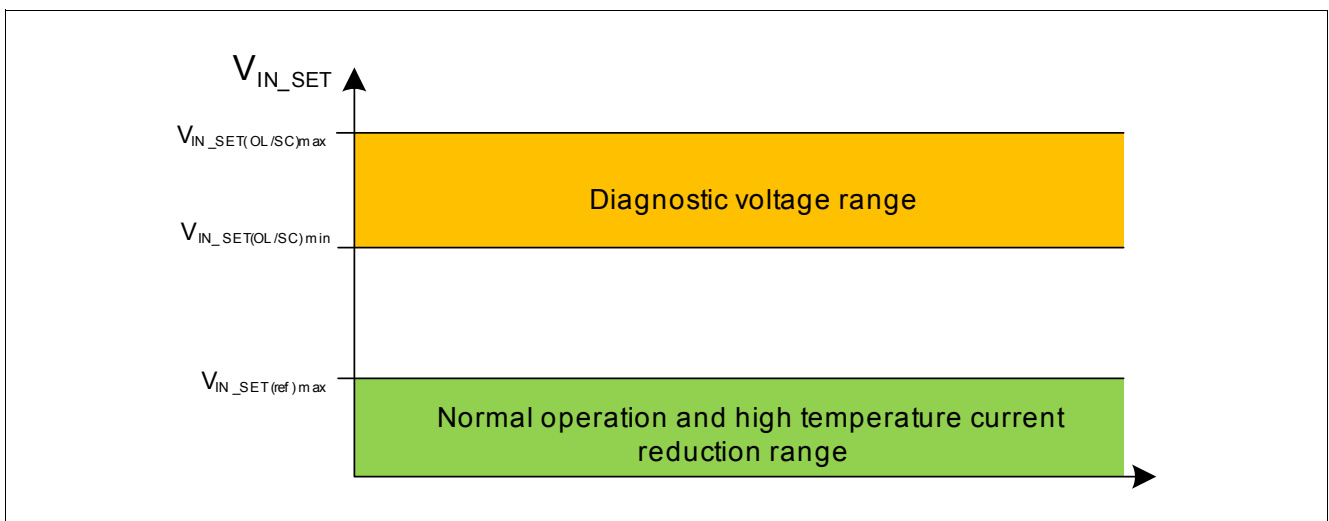

Figure 11 Voltage domains for IN_SET pin, if ST pin is connected to GND

7 ST Pin

The ST pin is a multiple function pin.

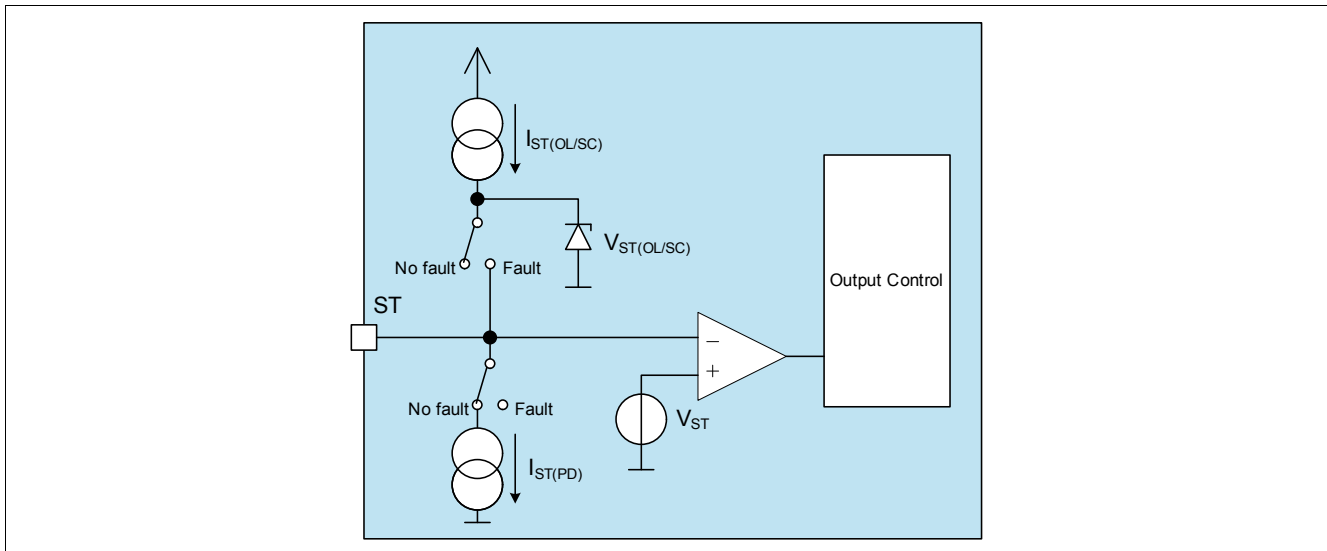

Figure 12 Block Diagram ST pin

7.1 Diagnosis Selector

If the voltage at the DEN pin V_{DEN} is higher than $V_{DEN(Act)}$, the diagnosis is activated. For details, please refer to [Chapter 5](#). If the status pin is unconnected or connected to GND via a high ohmic resistor (V_{ST} to be below $V_{ST(L)}$), the ST pin acts as diagnosis output pin. In normal operation (device is activated) the ST pin is pulled to GND via the internal pull down current $I_{ST(PD)}$. In case of an open load or short circuit to GND condition the ST pin is switched to $V_{ST(OL/SC)}$ after the open load or short circuit detection filter time ([Pos. 8.3.9](#), [Pos. 8.3.12](#)).

If the device is operated in PWM operation via the VS pin the ST pin should be connected to GND via a high ohmic resistor (e.g. 470 kΩ) to ensure proper device behavior during fast rising VS slope.

If the ST pin is shorted to GND the diagnostic feedback is performed via the IN_SET-pin, which is shown in [Chapter 6.2](#) and [Chapter 8](#).

7.2 Diagnosis Output

If the status pin is unconnected or connected to GND via a high ohmic resistor (V_{ST} to be below $V_{ST(L)}$), it acts as a diagnostic output, if the voltage at the DEN pin is above $V_{DEN(Act)}$. In case of a fault condition the ST pin rises its voltage to $V_{ST(OL/SC)}$ ([Pos. 8.3.7](#)). Details are shown in [Chapter 8](#).

7.3 Disable Input

If an external voltage higher than $V_{ST(H)}$ ([Pos. 8.3.5](#)) is applied to the ST pin, the device is switched off. This function is working independently of the voltage at the DEN pin. Even if the diagnosis is disabled via $V_{DEN} < V_{DEN(dis)}$ the disable function of the ST pin is working. This function is used for applications, where multiple drivers should be used for one light function. It is possible to combine the drivers' fault diagnosis via the ST pins. If a single LED chain fails, the entire light function is switched off. In this scenario e.g. the diagnostic circuit on the body control module can easily distinguish between the two cases (normal load or load fault), because nearly no current is flowing into the LED module during the fault scenario - the drivers consume a current of $I_{S(fault,STu)}$ ([Pos. 5.1.4](#)) or $I_{S(dis,ST)}$ ([Pos. 5.1.2](#)).

ST Pin

As soon as one LED chain fails, the ST-pin of this device is switched to $V_{ST(OL/SC)}$. The other devices used for the same light function can be connected together via the ST pins. This leads to a switch off of all devices connected together. Application examples are shown in [Chapter 10](#).

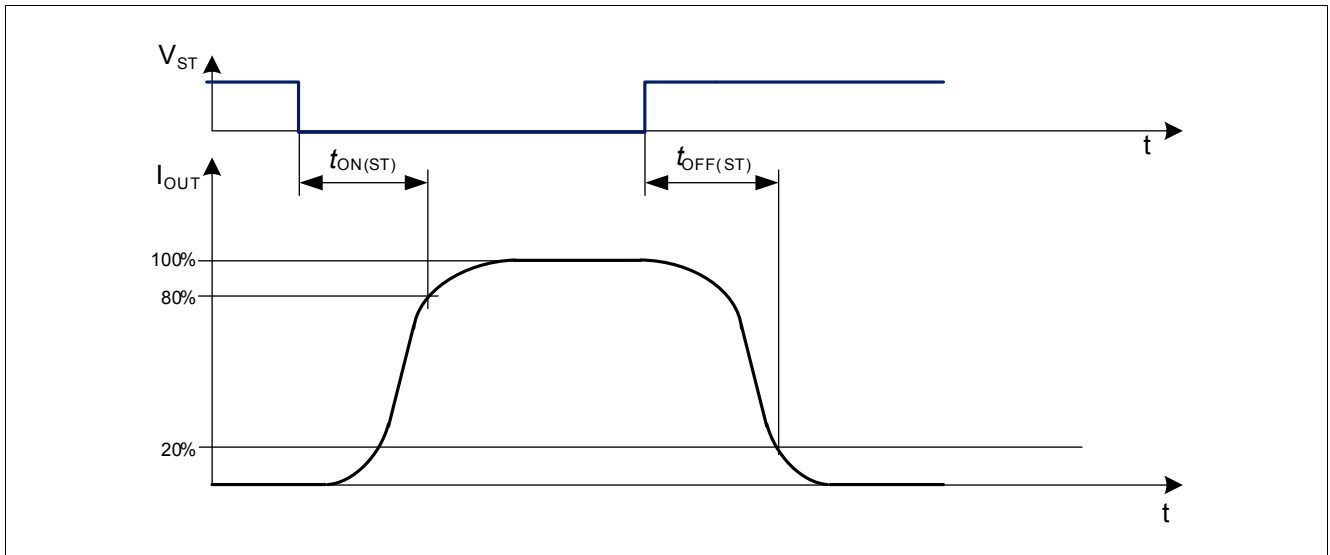

Figure 13 Switching times via ST Pin

Load Diagnosis

8 Load Diagnosis

The diagnosis function is enabled, if the voltage at the DEN pin V_{DEN} is above $V_{DEN(Act)}$ as described in [Chapter 5](#).

8.1 Open Load

An open load diagnosis feature is integrated in the TLD1124EL driver IC. If there is an open load on the output, the output is turned off. The potential on the IN_SET pin rises up to $V_{IN_SET(OL/SC)}$. This high voltage can be used as input signal for a μC as shown in [Figure 8](#). The open load status is not latched, as soon as the open load condition is no longer present, the output stage will be turned on again. An open load condition is detected, if the voltage drop over the output stage V_{PS} is below the threshold according [Pos. 8.3.10](#) and a filter time of t_{OL} is passed.

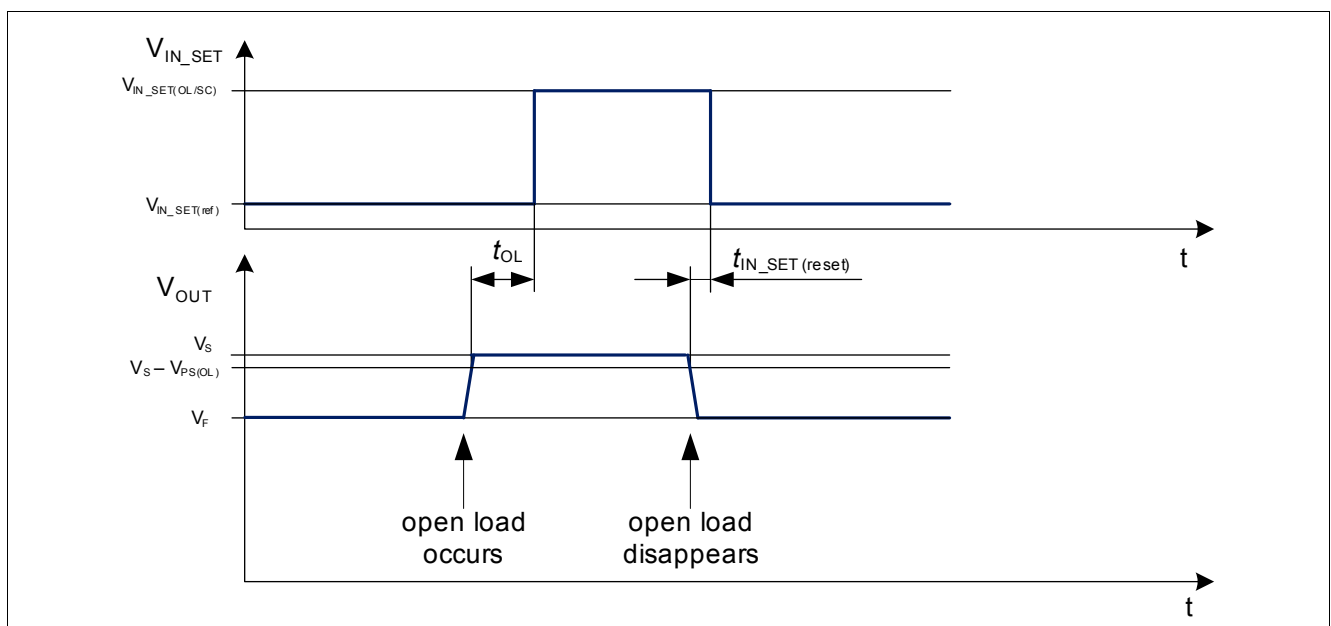

Figure 14 IN_SET behavior during open load condition with ST pin connected to GND and $V_{DEN} > V_{DEN(Act)}$

Load Diagnosis

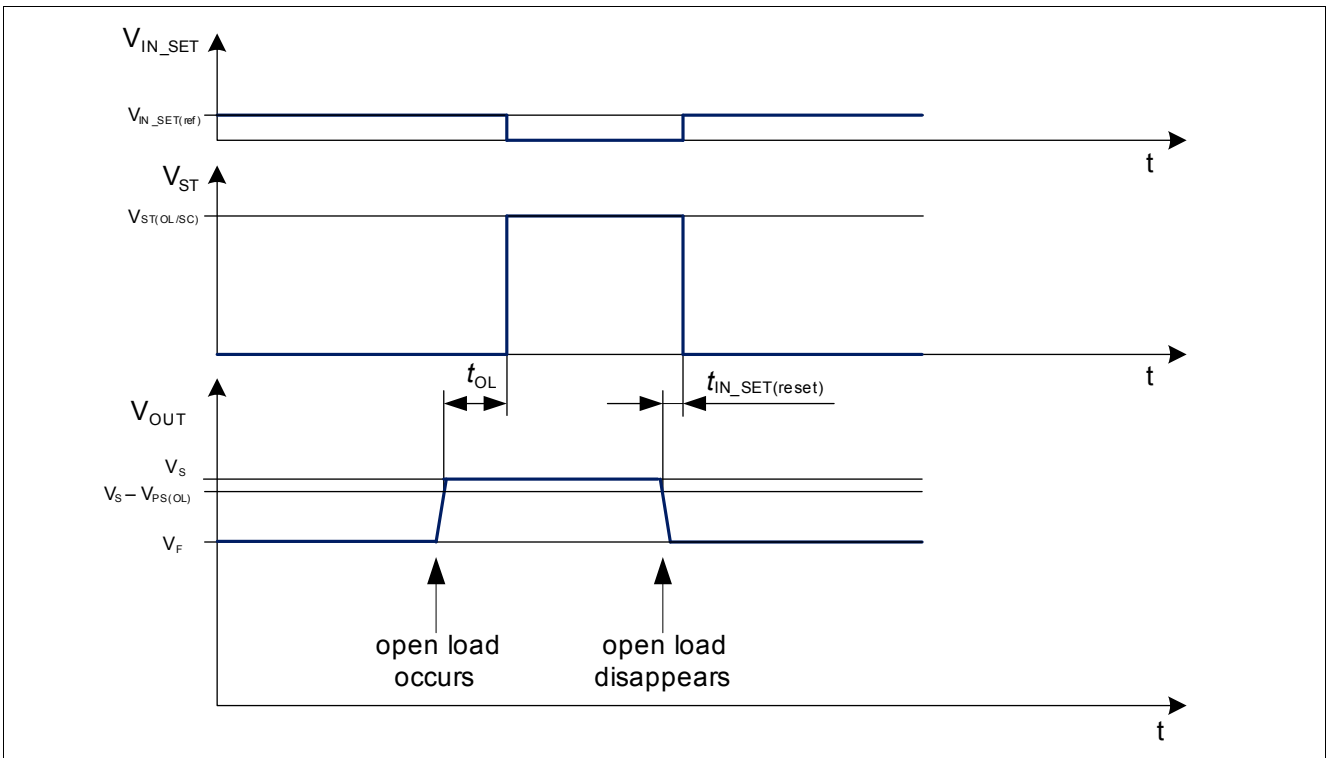

Figure 15 IN_SET and ST behavior during open load condition (ST unconnected) and $V_{DEN} > V_{DEN(act)}$

8.2 Short Circuit to GND detection

The TLD1124EL has an integrated SC to GND detection. If the output stage is turned on and the voltage at the output falls below $V_{OUT(SC)}$ the potential on the IN_SET pin is increased up to $V_{IN_SET(OL/SC)}$ after t_{SC} , if the ST pin is connected to GND. If the ST is open or connected to GND via a high ohmic resistor the fault is indicated on the ST pin according to [Chapter 7](#) after t_{SC} . More details are shown in [Figure 17](#). This condition is not latched. For detecting a normal condition after a short circuit detection an output current according to $I_{OUT(SC)}$ is driven by the channel.

Load Diagnosis

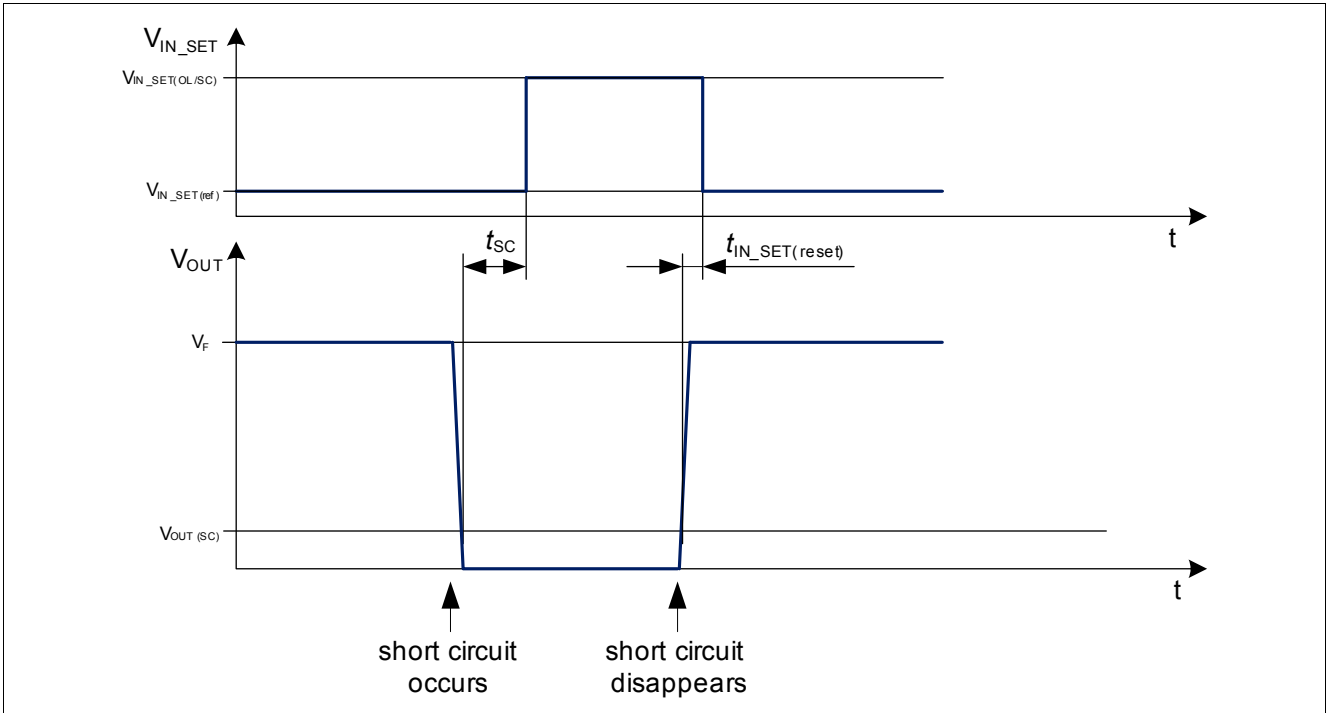

Figure 16 IN_SET behavior during short circuit to GND condition with ST connected to GND and $V_{DEN} > V_{DEN(act)}$

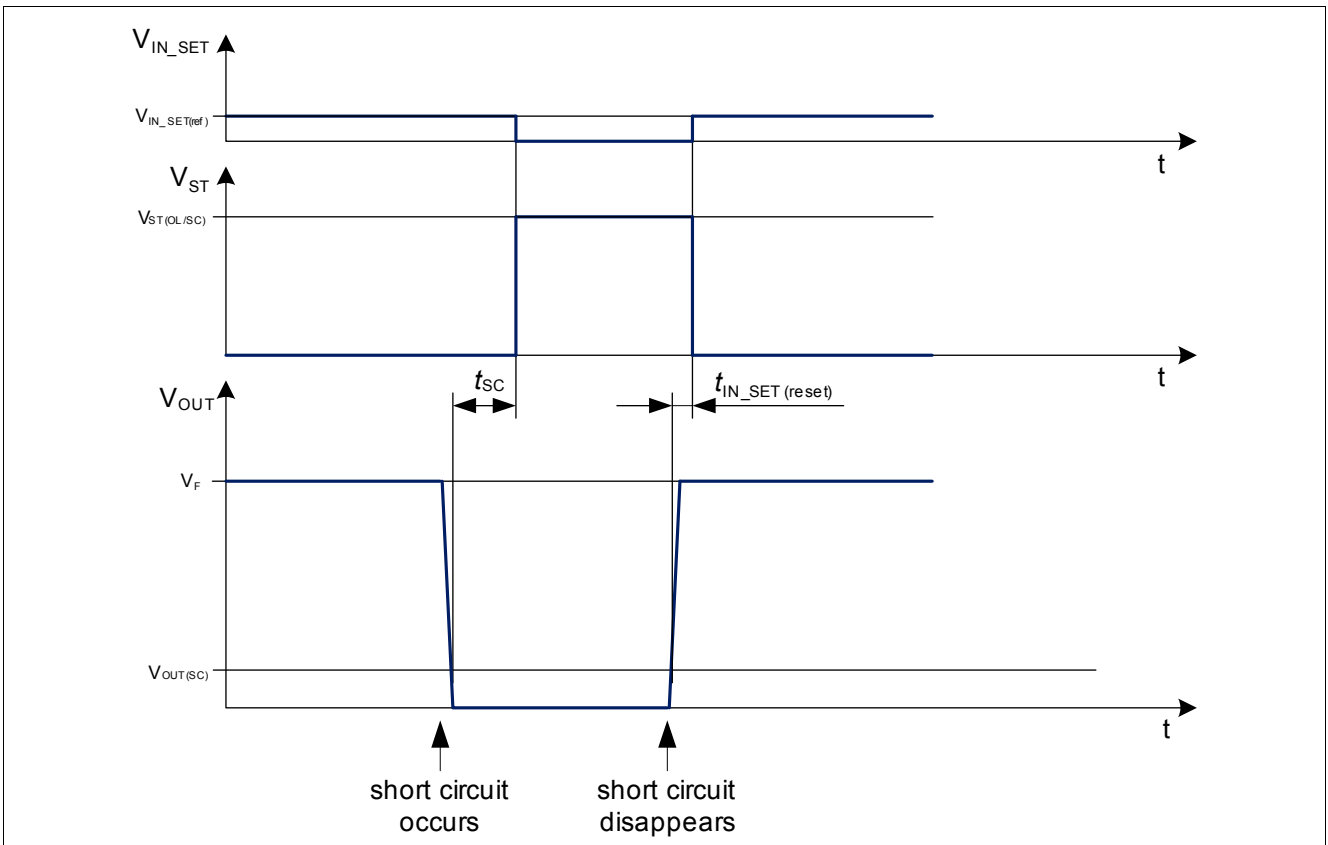

Figure 17 IN_SET and ST behavior during short circuit to GND condition (ST unconnected) and $V_{DEN} > V_{DEN(act)}$

Load Diagnosis

8.3 Electrical Characteristics IN_SET Pin and Load Diagnosis

Electrical Characteristics IN_SET pin and Load Diagnosis

Unless otherwise specified: $V_S = 5.5 \text{ V to } 40 \text{ V}$, $T_j = -40^\circ\text{C to } +150^\circ\text{C}$, $R_{SET} = 12 \text{ k}\Omega$, $V_{DEN} = 5.5 \text{ V}$, all voltages with respect to ground, positive current flowing into pin for input pins (I), positive currents flowing out of the I/O and output pins (O) (unless otherwise specified)

Pos.	Parameter	Symbol	Limit Values			Unit	Conditions
			Min.	Typ.	Max.		
8.3.1	IN_SET reference voltage	$V_{IN_SET(ref)}$	1.19	1.23	1.27	V	¹⁾ $V_{OUT} = 3.6 \text{ V}$ $T_j = 25...115^\circ\text{C}$
8.3.2	IN_SET open load/short circuit voltage	$V_{IN_SET(OL/SC)}$	4	–	5.5	V	¹⁾ $V_S > 8 \text{ V}$ $T_j = 25...150^\circ\text{C}$ $V_S = V_{OUT} \text{ (OL) or } V_{OUTx} = 0 \text{ V (SC)}$
8.3.3	IN_SET open load/short circuit current	$I_{IN_SET(OL/SC)}$	1.5	–	7.4	mA	¹⁾ $V_S > 8 \text{ V}$ $T_j = 25...150^\circ\text{C}$ $V_{IN_SET} = 4 \text{ V}$ $V_S = V_{OUT} \text{ (OL) or } V_{OUT} = 0 \text{ V (SC)}$
8.3.4	ST device turn on threshold (active low) in case of voltage applied from external (ST-pin acting as input)	$V_{ST(L)}$	0.8	–	–	V	–
8.3.5	ST device turn off threshold (active low) in case of voltage applied from external (ST-pin acting as input)	$V_{ST(H)}$	–	–	2.5	V	–
8.3.6	ST pull down current	$I_{ST(PD)}$	–	–	15	μA	$V_{ST} = 0.8 \text{ V}$
8.3.7	ST open load/short circuit voltage (ST-pin acting as diagnosis output)	$V_{ST(OL/SC)}$	4	–	5.5	V	¹⁾ $V_S > 8 \text{ V}$ $T_j = 25...150^\circ\text{C}$ $R_{ST} = 470 \text{ k}\Omega$ $V_S = V_{OUT} \text{ (OL) or } V_{OUT} = 0 \text{ V (SC)}$
8.3.8	ST open load/short circuit current (ST-pin acting as diagnosis output)	$I_{ST(OL/SC)}$	100	–	220	μA	¹⁾ $V_S > 8 \text{ V}$ $T_j = 25...150^\circ\text{C}$ $V_{ST} = 2.5 \text{ V}$ $V_S = V_{OUT} \text{ (OL) or } V_{OUT} = 0 \text{ V (SC)}$
8.3.9	OL detection filter time	t_{OL}	10	22	35	μs	¹⁾ $V_S > 8 \text{ V}$
8.3.10	OL detection voltage $V_{PS(OL)} = V_S - V_{OUT}$	$V_{PS(OL)}$	0.2	–	0.4	V	$V_S > 8 \text{ V}$
8.3.11	Short circuit to GND detection threshold	$V_{OUT(SC)}$	0.8	–	1.4	V	$V_S > 8 \text{ V}$
8.3.12	SC detection filter time	t_{SC}	10	22	35	μs	¹⁾ $V_S > 8 \text{ V}$
8.3.13	IN_SET diagnosis reset time	$t_{IN_SET(reset)}$	–	5	20	μs	¹⁾ $V_S > 8 \text{ V}$

Load Diagnosis

Electrical Characteristics IN_SET pin and Load Diagnosis (cont'd)

Unless otherwise specified: $V_S = 5.5\text{ V to }40\text{ V}$, $T_j = -40^\circ\text{C to }+150^\circ\text{C}$, $R_{SET} = 12\text{ k}\Omega$, $V_{DEN} = 5.5\text{ V}$, all voltages with respect to ground, positive current flowing into pin for input pins (I), positive currents flowing out of the I/O and output pins (O) (unless otherwise specified)

Pos.	Parameter	Symbol	Limit Values			Unit	Conditions
			Min.	Typ.	Max.		
8.3.14	SC detection current in case of unconnected ST-pin	$I_{OUT(SC,STu)}$	100	200	300	μA	$V_S > 8\text{ V}$ $V_{OUT} = 0\text{ V}$
8.3.15	SC detection current in case of ST-pin shorted to GND	$I_{OUT(SC,STG)}$	0.1	2	4.75	mA	$V_S > 8\text{ V}$ $V_{OUT} = 0\text{ V}$ $V_{ST} = 0\text{ V}$
8.3.16	IN_SET activation current without turn on of output stage	$I_{IN_SET(act)}$	2	–	15	μA	See Figure 10

1) Not subject to production test, specified by design

Power Stage

9 Power Stage

The output stage is realized as high side current source with a current of 360 mA. During off state the leakage current at the output stage is minimized in order to prevent a slightly glowing LED.

The maximum current of the channel is limited by the power dissipation and used PCB cooling areas (which results in the applications R_{thJA}).

For an operating current control loop the supply and output voltages according to the following parameters have to be considered:

- Required supply voltage for current control $V_{S(CC)}$, **Pos. 5.1.7**
- Voltage drop over output stage during current control $V_{PS(CC)}$, **Pos. 9.2.6**
- Required output voltage for current control $V_{OUT(CC)}$, **Pos. 9.2.7**

9.1 Protection

The device provides embedded protective functions, which are designed to prevent IC destruction under fault conditions described in this data sheet. Fault conditions are considered as “outside” normal operating range. Protective functions are neither designed for continuous nor for repetitive operation.

9.1.1 Over Load Behavior

An over load detection circuit is integrated in the LITIX™ Basic IC. It is realized by a temperature monitoring of the output stage (OUT).

As soon as the junction temperature exceeds the current reduction temperature threshold $T_{j(CRT)}$ the output current will be reduced by the device by reducing the IN_SET reference voltage $V_{IN_SET(ref)}$. This feature avoids LED’s flickering during static output overload conditions. Furthermore, it protects LEDs against over temperature, which are mounted thermally close to the device. If the device temperature still increases, the output current decreases close to 0 A. As soon as the device cools down the output current rises again.

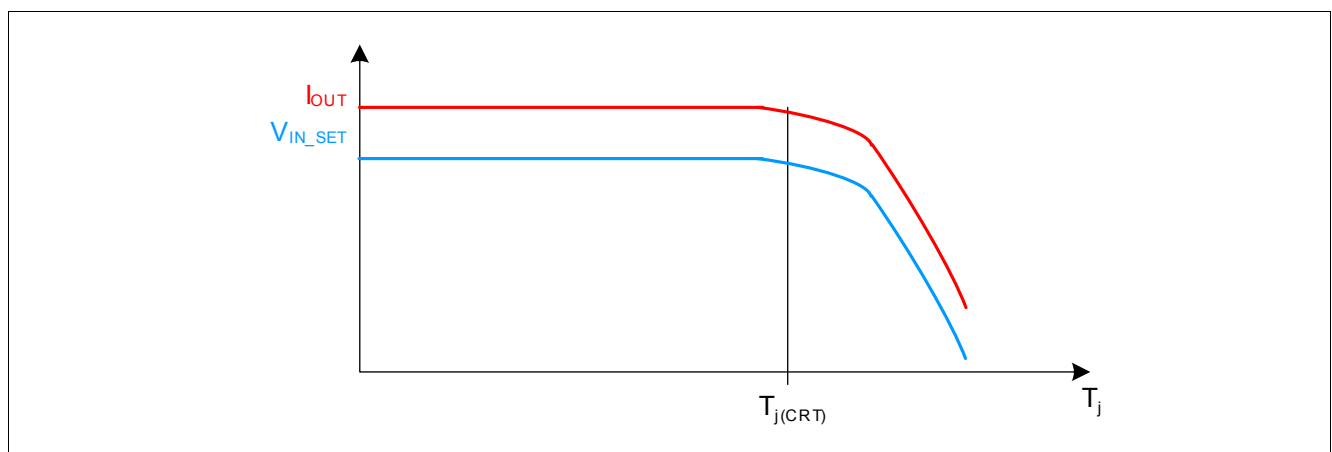

Figure 18 Output current reduction at high temperature

Note: This high temperature output current reduction is realized by reducing the IN_SET reference voltage (Pos. 8.3.1). In case of very high power loss applied to the device and very high junction temperature the output current may drop down to $I_{OUT} = 0$ mA, after a slight cooling down the current increases again.

9.1.2 Reverse Battery Protection

The TLD1124EL has an integrated reverse battery protection feature. This feature protects the driver IC itself, but also connected LEDs. The output reverse current is limited to $I_{OUTx(rev)}$ by the reverse battery protection.

Power Stage

Note: Due to the reverse battery protection a reverse protection diode for the light module may be obsolete. In case of high ISO-pulse requirements and only minor protecting components like capacitors a reverse protection diode may be reasonable. The external protection circuit needs to be verified in the application.

9.2 Electrical Characteristics Power Stage

Electrical Characteristics Power Stage

Unless otherwise specified: $V_S = 5.5\text{ V to }18\text{ V}$, $T_j = -40^\circ\text{C to }+150^\circ\text{C}$, $V_{OUT} = 3.6\text{ V}$, all voltages with respect to ground, positive current flowing into pin for input pins (I), positive currents flowing out of the I/O and output pins (O) (unless otherwise specified)

Pos.	Parameter	Symbol	Limit Values			Unit	Conditions
			Min.	Typ.	Max.		
9.2.1	Output leakage current	$I_{OUT(leak)}$	-	-	21 9	μA	$I_{IN_SET} = 0\ \mu\text{A}$ $V_{OUT} = 2.5\text{ V}$ $T_j = 150^\circ\text{C}$ ¹⁾ $T_j = 85^\circ\text{C}$
9.2.2	Output leakage current in boost over battery setup	$-I_{OUT(leak,B2B)}$	-	-	150	μA	¹⁾ $I_{IN_SET} = 0\ \mu\text{A}$ $V_{OUT} = V_S = 40\text{ V}$
9.2.3	Reverse output current	$-I_{OUT(rev)}$	-	-	3	μA	¹⁾ $V_S = -16\text{ V}$ Output load: LED with break down voltage < -0.6 V
9.2.4	Output current accuracy limited temperature range	k_{LT}	2092 1935	2250 2250	2408 2565		¹⁾ $T_j = 25...115^\circ\text{C}$ $V_S = 8...18\text{ V}$ $V_{PS} = 2\text{ V}$ $R_{SET} = 6...12\text{ k}\Omega$ $R_{SET} = 30\text{ k}\Omega$
9.2.5	Output current accuracy over temperature	k_{ALL}	2092 1935	2250 2250	2408 2565		¹⁾ $T_j = -40...115^\circ\text{C}$ $V_S = 8...18\text{ V}$ $V_{PS} = 2\text{ V}$ $R_{SET} = 6...12\text{ k}\Omega$ $R_{SET} = 30\text{ k}\Omega$
9.2.6	Voltage drop over power stage during current control $V_{PS(CC)} = V_S - V_{OUT}$	$V_{PS(CC)}$	0.75	-	-	V	¹⁾ $V_S = 13.5\text{ V}$ $R_{SET} = 12\text{ k}\Omega$ $I_{OUT} \geq 90\%$ of $(k_{LT(typ)}/R_{SET})$
9.2.7	Required output voltage for current control	$V_{OUT(CC)}$	2.3	-	-	V	¹⁾ $V_S = 13.5\text{ V}$ $R_{SET} = 12\text{ k}\Omega$ $I_{OUT} \geq 90\%$ of $(k_{LT(typ)}/R_{SET})$
9.2.8	Maximum output current	$I_{OUT(max)}$	360	-	-	mA	$R_{SET} = 4.7\text{ k}\Omega$ The maximum output current is limited by the thermal conditions. Please refer to Pos. 4.3.1 - Pos. 4.3.3
9.2.9	ST turn on time	$t_{ON(ST)}$	-	-	15	μs	²⁾ $V_S = 13.5\text{ V}$ $R_{SET} = 12\text{ k}\Omega$ ST \rightarrow L $I_{OUT} = 80\%$ of $(k_{LT(typ)}/R_{SET})$

Power Stage

Electrical Characteristics Power Stage (cont'd)

Unless otherwise specified: $V_S = 5.5\text{ V to }18\text{ V}$, $T_j = -40^\circ\text{C to }+150^\circ\text{C}$, $V_{OUT} = 3.6\text{ V}$, all voltages with respect to ground, positive current flowing into pin for input pins (I), positive currents flowing out of the I/O and output pins (O) (unless otherwise specified)

Pos.	Parameter	Symbol	Limit Values			Unit	Conditions
			Min.	Typ.	Max.		
9.2.10	ST turn off time	$t_{OFF(ST)}$	-	-	10	μs	²⁾ $V_S = 13.5\text{ V}$ $R_{SET} = 12\text{ k}\Omega$ ST \rightarrow H $I_{OUT} = 20\%$ of $(k_{LT(typ)}/R_{SET})$
9.2.11	IN_SET turn on time	$t_{ON(IN_SET)}$	-	-	15	μs	$V_S = 13.5\text{ V}$ $I_{IN_SET} = 0 \rightarrow 100\text{ }\mu\text{A}$ $I_{OUT} = 80\%$ of $(k_{LT(typ)}/R_{SET})$
9.2.12	IN_SET turn off time	$t_{OFF(IN_SET)}$	-	-	10	μs	$V_S = 13.5\text{ V}$ $I_{IN_SET} = 100 \rightarrow 0\text{ }\mu\text{A}$ $I_{OUT} = 20\%$ of $(k_{LT(typ)}/R_{SET})$
9.2.13	Current reduction temperature threshold	$T_{j(CRT)}$	-	140	-	$^\circ\text{C}$	¹⁾ $I_{OUT} = 95\%$ of $(k_{LT(typ)}/R_{SET})$
9.2.14	Output current during current reduction at high temperature	$I_{OUT(CRT)}$	85% of $(k_{LT(typ)}/R_{SET})$	-	-	A	¹⁾ $R_{SET} = 12\text{ k}\Omega$ $T_j = 150\text{ }^\circ\text{C}$

1) Not subject to production test, specified by design

2) see also [Figure 13](#)

Application Information

10 Application Information

Note: The following information is given as a hint for the implementation of the device only and shall not be regarded as a description or warranty of a certain functionality, condition or quality of the device.

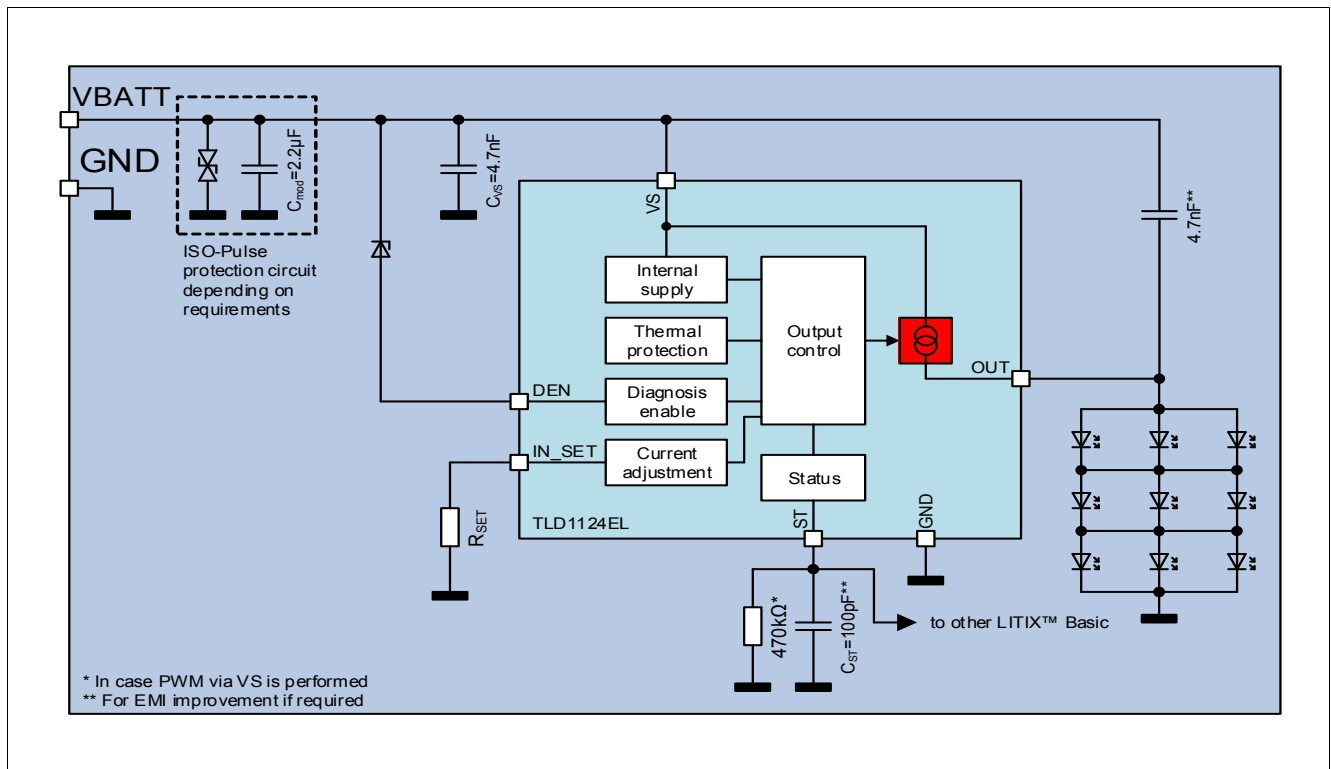

Figure 19 Application Diagram

Note: This is a very simplified example of an application circuit. In case of high ISO-pulse requirements a reverse protection diode may be used for LED protection. The function must be verified in the real application.

10.1 Further Application Information

- For further information you may contact <http://www.infineon.com/>

11 Package Outlines

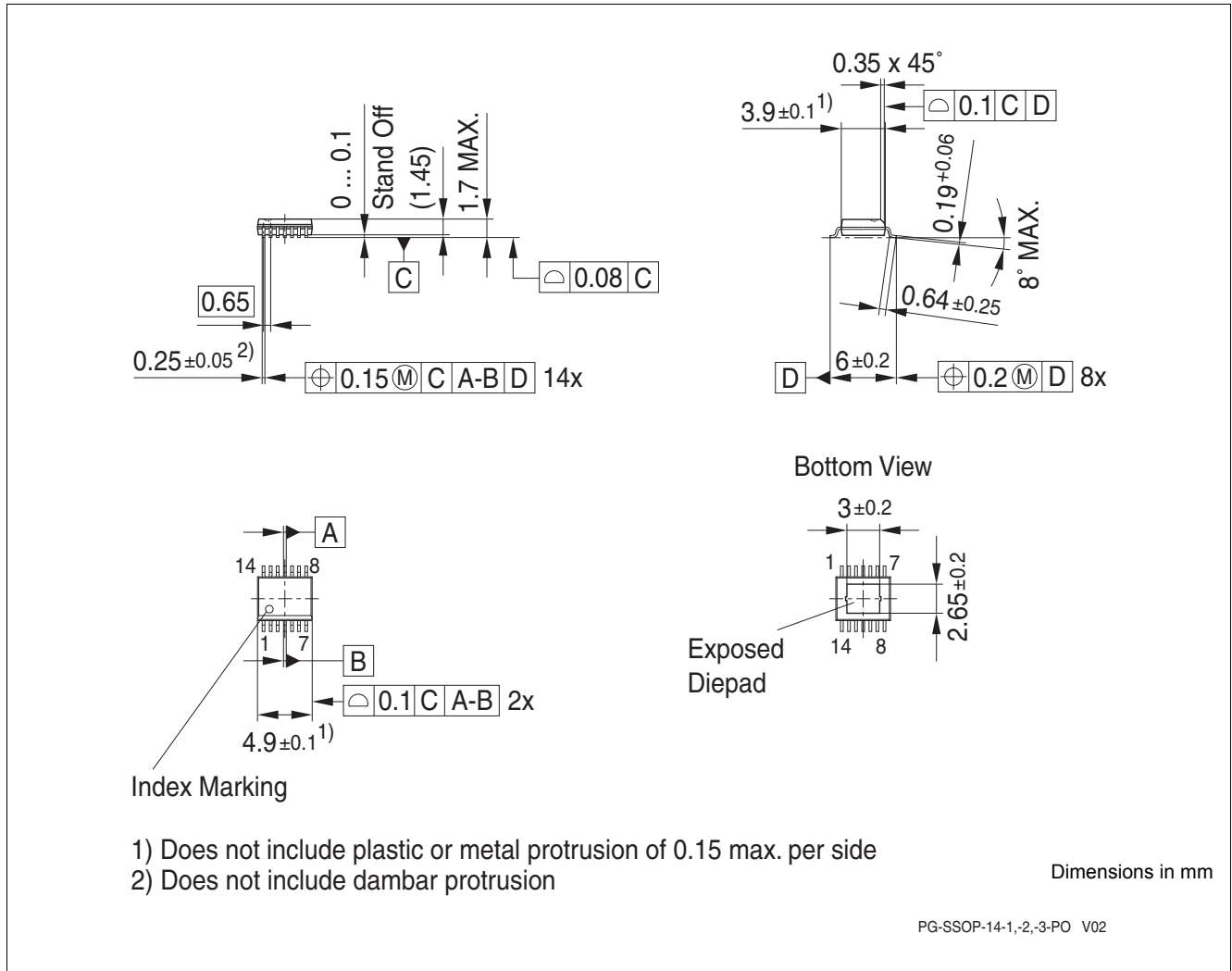

Figure 20 PG-SSOP-14

Green Product (RoHS compliant)

To meet the world-wide customer requirements for environmentally friendly products and to be compliant with government regulations the device is available as a green product. Green products are RoHS-Compliant (i.e Pb-free finish on leads and suitable for Pb-free soldering according to IPC/JEDEC J-STD-020).

For further information on alternative packages, please visit our website:
<http://www.infineon.com/packages>.

Revision History

12 Revision History

Revision	Date	Changes
1.0	2013-08-08	Initial revision of data sheet
1.1	2015-03-19	Updated parameters K_{LT} and K_{ALL} in the chapter Power Stage
1.2	2018-04-26	Updated to latest template
1.2	2018-04-26	Updated application drawing
1.2	2018-04-26	Updated package marking
1.2	2018-04-26	Updated package figure

Table of Contents

1	Overview	1
2	Block Diagram	3
3	Pin Configuration	4
3.1	Pin Assignment	4
3.2	Pin Definitions and Functions	5
4	General Product Characteristics	6
4.1	Absolute Maximum Ratings	6
4.2	Functional Range	7
4.3	Thermal Resistance	7
5	DEN Pin	8
5.1	Electrical Characteristics Internal Supply / DEN Pin	9
6	IN_SET Pin	11
6.1	Output Current Adjustment via RSET	11
6.2	Smart Input Pin	11
7	ST Pin	14
7.1	Diagnosis Selector	14
7.2	Diagnosis Output	14
7.3	Disable Input	14
8	Load Diagnosis	16
8.1	Open Load	16
8.2	Short Circuit to GND detection	17
8.3	Electrical Characteristics IN_SET Pin and Load Diagnosis	19
9	Power Stage	21
9.1	Protection	21
9.1.1	Over Load Behavior	21
9.1.2	Reverse Battery Protection	21
9.2	Electrical Characteristics Power Stage	22
10	Application Information	24
10.1	Further Application Information	24
11	Package Outlines	25
12	Revision History	26
	Table of Contents	27

Trademarks

All referenced product or service names and trademarks are the property of their respective owners.

Edition 2018-04-26

Published by

Infineon Technologies AG

81726 Munich, Germany

© 2018 Infineon Technologies AG.

All Rights Reserved.

Do you have a question about any aspect of this document?

Email: erratum@infineon.com

Document reference

TLD1124EL

IMPORTANT NOTICE

The information given in this document shall in no event be regarded as a guarantee of conditions or characteristics ("Beschaffheitsgarantie").

With respect to any examples, hints or any typical values stated herein and/or any information regarding the application of the product, Infineon Technologies hereby disclaims any and all warranties and liabilities of any kind, including without limitation warranties of non-infringement of intellectual property rights of any third party.

In addition, any information given in this document is subject to customer's compliance with its obligations stated in this document and any applicable legal requirements, norms and standards concerning customer's products and any use of the product of Infineon Technologies in customer's applications.

The data contained in this document is exclusively intended for technically trained staff. It is the responsibility of customer's technical departments to evaluate the suitability of the product for the intended application and the completeness of the product information given in this document with respect to such application.

For further information on technology, delivery terms and conditions and prices, please contact the nearest Infineon Technologies Office (www.infineon.com).

WARNINGS

Due to technical requirements products may contain dangerous substances. For information on the types in question please contact your nearest Infineon Technologies office.

Except as otherwise explicitly approved by Infineon Technologies in a written document signed by authorized representatives of Infineon Technologies, Infineon Technologies' products may not be used in any applications where a failure of the product or any consequences of the use thereof can reasonably be expected to result in personal injury.



Компания «ЭлектроПласт» предлагает заключение долгосрочных отношений при поставках импортных электронных компонентов на взаимовыгодных условиях!

Наши преимущества:

- Оперативные поставки широкого спектра электронных компонентов отечественного и импортного производства напрямую от производителей и с крупнейших мировых складов;
- Поставка более 17-ти миллионов наименований электронных компонентов;
- Поставка сложных, дефицитных, либо снятых с производства позиций;
- Оперативные сроки поставки под заказ (от 5 рабочих дней);
- Экспресс доставка в любую точку России;
- Техническая поддержка проекта, помощь в подборе аналогов, поставка прототипов;
- Система менеджмента качества сертифицирована по Международному стандарту ISO 9001;
- Лицензия ФСБ на осуществление работ с использованием сведений, составляющих государственную тайну;
- Поставка специализированных компонентов (Xilinx, Altera, Analog Devices, Intersil, Interpoint, Microsemi, Aeroflex, Peregrine, Syfer, Eurofarad, Texas Instrument, Miteq, Cobham, E2V, MA-COM, Hittite, Mini-Circuits, General Dynamics и др.);

Помимо этого, одним из направлений компании «ЭлектроПласт» является направление «Источники питания». Мы предлагаем Вам помощь Конструкторского отдела:

- Подбор оптимального решения, техническое обоснование при выборе компонента;
- Подбор аналогов;
- Консультации по применению компонента;
- Поставка образцов и прототипов;
- Техническая поддержка проекта;
- Защита от снятия компонента с производства.



Как с нами связаться

Телефон: 8 (812) 309 58 32 (многоканальный)

Факс: 8 (812) 320-02-42

Электронная почта: org@eplast1.ru

Адрес: 198099, г. Санкт-Петербург, ул. Калинина, дом 2, корпус 4, литера А.