

Features

- High Isolation: 60 dB @ 2.1 GHz
- Insertion Loss: 0.8 dB @ 2.1 GHz
- Input IP3: 50 dBm Typical @ 2.1 GHz
- Integral CMOS Decoder
- Low Gate Lag for timing sensitive applications
- 5 States: 4 ON paths and All-Off State
- 50 Ω Terminated Outputs (Off-State)
- Lead-Free 4 mm 24-Lead PQFN package
- RoHS* Compliant and 260°C Reflow Compatible
- Optional 2 Control Operation (no All-Off State)

Description

The MASW-010350 is an industry leading high isolation single pole four throw (SP4T) switch. This device design is optimized to take advantage of separate GaAs pHEMT switch die and CMOS driver die. The switch circuit design is symmetric and combined with the separate CMOS decoder allows it to maintain an excellent combination of insertion loss and isolation for all states. This makes the device ideal for band switching in multi-channel and multi-mode base-station applications as well as other applications where a compact, high isolation, SP4T switch is required.

The MASW-010350 switch die is fabricated using a mature 0.5 micron gate length GaAs pHEMT process and features full passivation for enhanced performance and reliability.

The MASW-010350 is offered in an industry standard lead-free 4mm 24-Lead PQFN RoHS compliant plastic package, which is ideal for high volume surface mount reflow assembly.

Ordering Information ^{1,2}

Part Number	Package
MASW-010350-TR3000	3000 piece reel
MASW-010350-001SMB	Sample Test Board

1. Reference Application Note M513 for reel size information.
2. All sample boards include 5 loose parts.

*Restrictions on Hazardous Substances, European Union Directive 2002/95/EC.

Functional Schematic

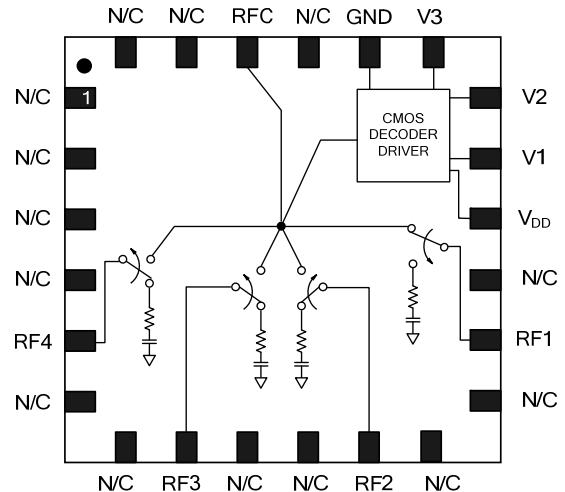

Pin Configuration ^{3,4}

Pin No.	Description	Pin No.	Description
1	No Connection	13	No Connection
2	No Connection	14	RF1
3	No Connection	15	No Connection
4	No Connection	16	V _{DD}
5	RF4	17	V1 Control
6	No Connection	18	V2 Control
7	No Connection	19	V3 Control
8	RF3	20	Ground
9	No Connection	21	No Connection
10	No Connection	22	RFC
11	RF2	23	No Connection
12	No Connection	24	No Connection
		25	Ground (paddle)

3. M/A-COM Technology Solutions recommends connecting all N/C pins to RF and DC ground in the PCB layout.
4. The exposed pad centered on the package bottom (P25) MUST be connected to RF and DC ground in the PCB layout.

SP4T High Isolation Terminated Switch 0.01 - 4.0 GHz

Rev. V1

Electrical Specifications ⁵: $T_A = +25^\circ\text{C}$, $Z_0 = 50 \Omega$, $V_{DD} = +3.0 \text{ V}$, $V_C = 0/+3.0 \text{ V}$

Parameter	Test Conditions	Units	Min.	Typ.	Max.
Insertion Loss (All Paths)	0.9 GHz	dB	—	0.8	—
	2.1 GHz			0.8	1.1
	2.6 GHz			1.6	—
	4.0 GHz			1.9	—
Isolation (RFC-RF1 & RFC-RF4)	0.9 GHz	dB	—	65	—
	2.1 GHz		55	60	
	2.6 GHz		—	55	
	4.0 GHz		—	45	
Isolation (RFC-RF2 & RFC-RF3)	0.9 GHz	dB	—	60	—
	2.1 GHz		50	55	
	2.6 GHz		—	52	
	4.0 GHz		—	40	
Return Loss (All RF ports)	2.1 GHz	dB	—	14	—
Input IP3	Two Tone, +10 dBm/tone, 5 MHz Spacing 2.1 GHz	dBm	—	50	—
Input P1dB	2.1 GHz	dBm	—	27	—
Trise, Tfall	10% to 90% RF, 90% to 10% RF RF = 2.1 GHz	ns	—	20	—
Ton, Toff	50% control to 90% RF, and 50% control to 10% RF RF = 2.1 GHz	ns	—	40	—
I_{DD}	$V_{DD} = +3.0\text{V}$	μA	—	1.0	—
Control Current	$V_C = 0\text{V} / +3.0\text{V}$	μA	—	1.0	5.0

5. External DC blocking capacitors are required on all RF ports. Typical performance specifications are with 1000 pF blocking and decoupling capacitors, as shown on the application schematic.

SP4T High Isolation Terminated Switch 0.01 - 4.0 GHz

Rev. V1

Absolute Maximum Ratings ^{6,7}

Parameter	Absolute Maximum
Max Input Power (RFC Port , ON state)	+20 dBm (0.05 - 0.5 GHz) +30 dBm (0.5 - 4.0 GHz)
V _{DD} Supply	-0.5 V to +7.0 V
Control Voltage	-0.5 V < V _C < V _{DD} +0.5 V (V _C not to exceed 7.0 V)
Operating Temperature	-40°C to +85°C
Storage Temperature	-65°C to +150°C

- Exceeding any one or combination of these limits may cause permanent damage to this device.
- M/A-COM Technology Solutions does not recommend sustained operation near these survivability limits.

Truth Table ^{11,12}

V1	V2	V3	RFC-RF1	RFC-RF2	RFC-RF3	RFC-RF4
0	0	0	Unsupported			
1	0	0	On	Off	Off	Off
0	1	0	Off	On	Off	Off
1	1	0	Off	Off	On	Off
0	0	1	Off	Off	Off	On
0	1	1	Off	Off	Off	Off
1	1	1	Off	Off	Off	Off

11. Positive Control: 1 = 0.7*V_{DD} to V_{DD}
0 = 0 V to 0.3*V_{DD}

12. See Application Section for optional 2 control operation for applications which do not require the All-Off condition.

Application Schematic ^{8,9,10}

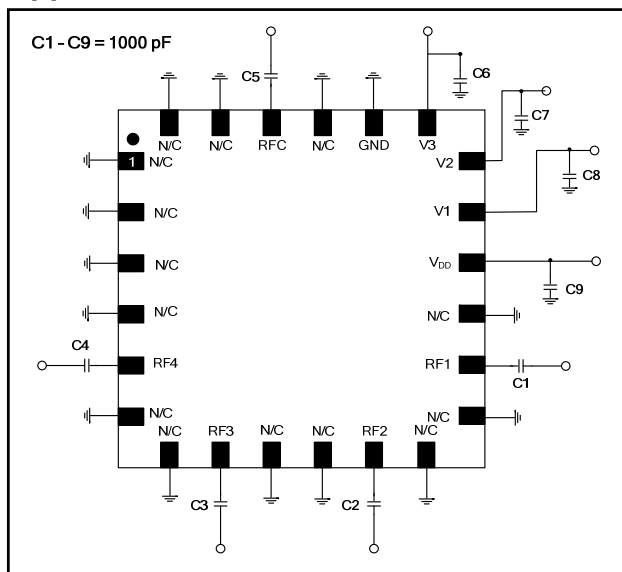

- The exposed pad centered on the package bottom must be connected to ground for RF, DC and thermal considerations.
- All blocking capacitors and decoupling capacitors = 1000 pF
- M/A-COM Technology Solutions recommends connecting all N/C pins to RF and DC ground in the PCB layout as shown.

Handling Procedures

Please observe the following precautions to avoid damage:

Static Sensitivity

Gallium Arsenide Integrated Circuits are sensitive to electrostatic discharge (ESD) and can be damaged by static electricity. Proper ESD control techniques should be used when handling these devices. An external protection circuit using ESD/Transient protection devices on the RF ports can be used to protect the IC if required in application.

Please reference application note AN3007 on <http://www.macomtech.com> for further detail.

Typical Performance Curves:

Insertion Loss

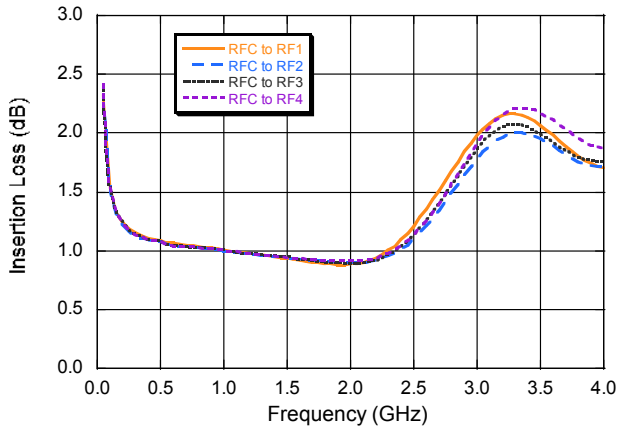

Insertion Loss

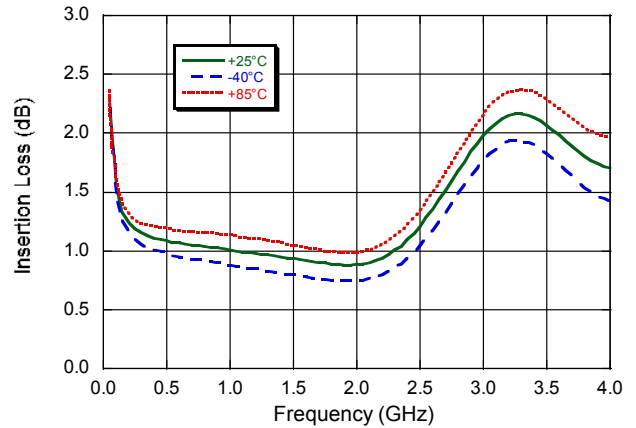

Isolation

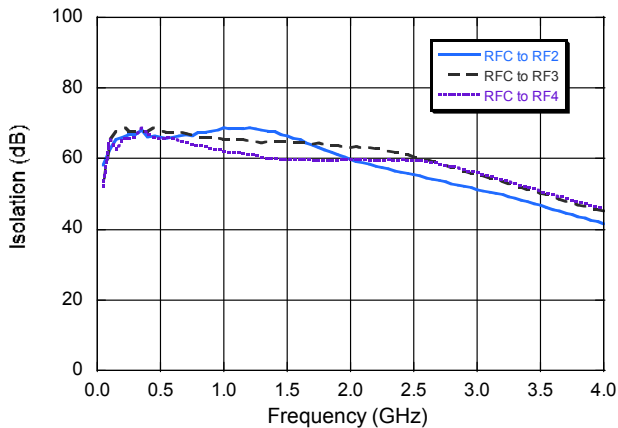

Isolation RFC - RF1

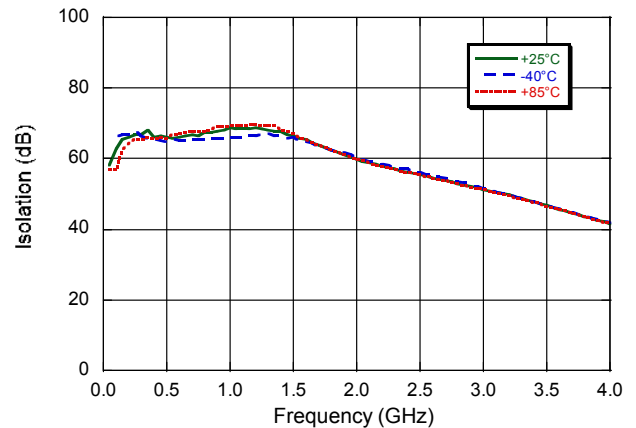

Lead-Free 4 mm 24-Lead PQFN[†]

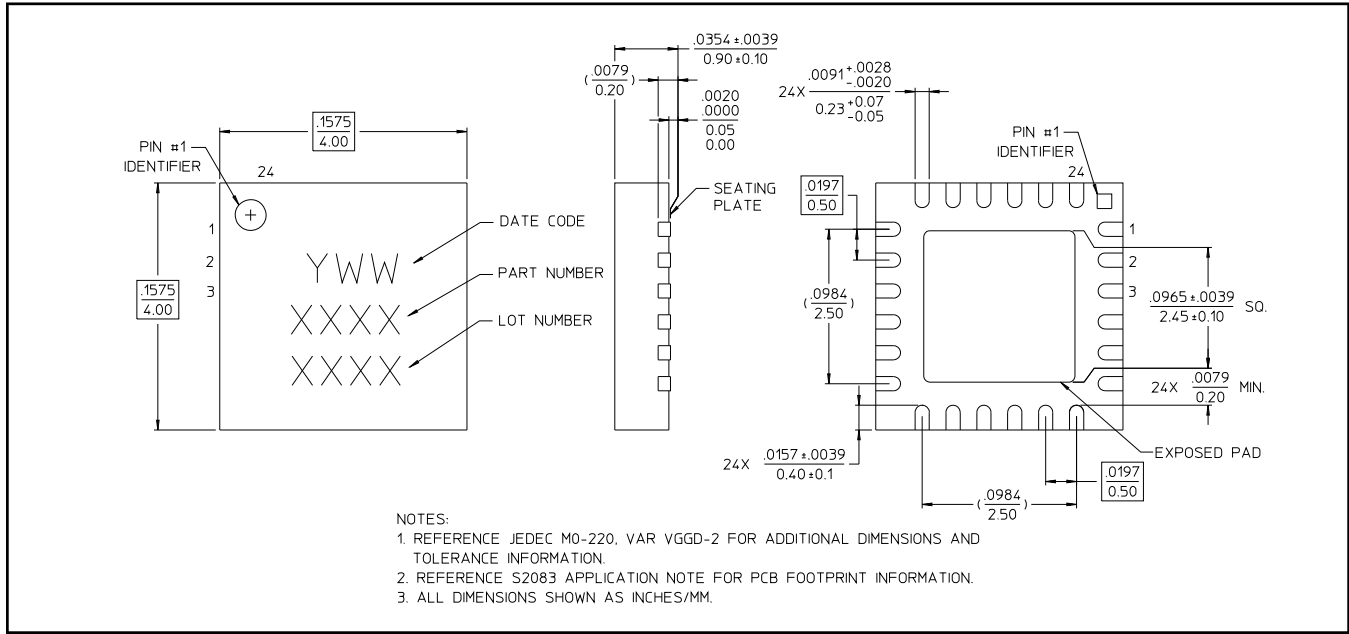

[†] Reference Application Note S2083 for lead-free solder reflow recommendations.
Meets JEDEC moisture sensitivity level 1 requirements.
Plating is 100% matte tin over copper.

Application Section

Application Schematic (2 Control)^{13,14,15,16}

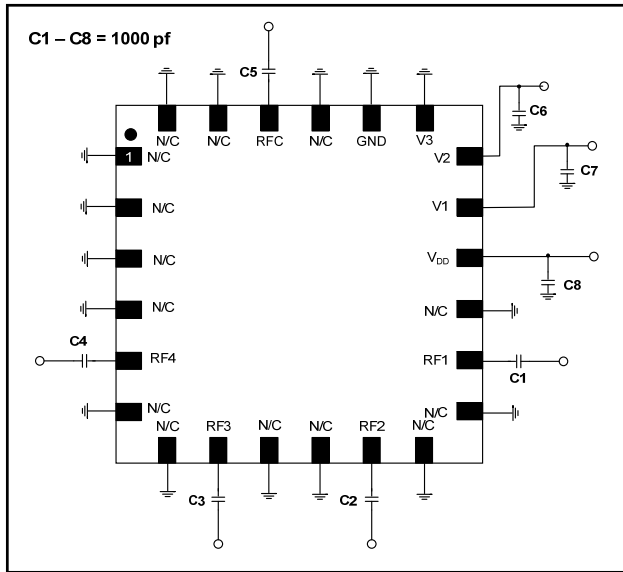

13. Configuration shown is for optional 2 control operation which does not include an All-Off condition. V3 pin must be connected to Ground externally as shown.
14. The exposed pad centered on the package bottom must be connected to ground for RF, DC and thermal considerations.
15. All blocking capacitors and decoupling capacitors = 1000 pF
16. M/A-COM Technology Solutions recommends connecting all N/C pins to RF and DC ground in the PCB layout as shown.

Truth Table (2 Control)^{17,18}

V1	V2	ANT-RF1	ANT-RF2	ANT-RF3	ANT-RF4
1	0	On	Off	Off	Off
0	1	Off	On	Off	Off
1	1	Off	Off	On	Off
0	0	Off	Off	Off	On

17. Truth Table shown is for optional 2 control operation which does not include an All-Off condition. V3 pin must be connected to ground externally.
18. Positive Control: 1 = $0.7 \cdot V_{DD}$ to V_{DD}
0 = 0 V to $0.3 \cdot V_{DD}$



Компания «ЭлектроПласт» предлагает заключение долгосрочных отношений при поставках импортных электронных компонентов на взаимовыгодных условиях!

Наши преимущества:

- Оперативные поставки широкого спектра электронных компонентов отечественного и импортного производства напрямую от производителей и с крупнейших мировых складов;
- Поставка более 17-ти миллионов наименований электронных компонентов;
- Поставка сложных, дефицитных, либо снятых с производства позиций;
- Оперативные сроки поставки под заказ (от 5 рабочих дней);
- Экспресс доставка в любую точку России;
- Техническая поддержка проекта, помощь в подборе аналогов, поставка прототипов;
- Система менеджмента качества сертифицирована по Международному стандарту ISO 9001;
- Лицензия ФСБ на осуществление работ с использованием сведений, составляющих государственную тайну;
- Поставка специализированных компонентов (Xilinx, Altera, Analog Devices, Intersil, Interpoint, Microsemi, Aeroflex, Peregrine, Syfer, Eurofarad, Texas Instrument, Miteq, Cobham, E2V, MA-COM, Hittite, Mini-Circuits, General Dynamics и др.);

Помимо этого, одним из направлений компании «ЭлектроПласт» является направление «Источники питания». Мы предлагаем Вам помощь Конструкторского отдела:

- Подбор оптимального решения, техническое обоснование при выборе компонента;
- Подбор аналогов;
- Консультации по применению компонента;
- Поставка образцов и прототипов;
- Техническая поддержка проекта;
- Защита от снятия компонента с производства.



Как с нами связаться

Телефон: 8 (812) 309 58 32 (многоканальный)

Факс: 8 (812) 320-02-42

Электронная почта: org@eplast1.ru

Адрес: 198099, г. Санкт-Петербург, ул. Калинина, дом 2, корпус 4, литера А.