

3M™ Wiremount Plug

.100" × .100" Connector for .050" Pitch Cable

4600 Series

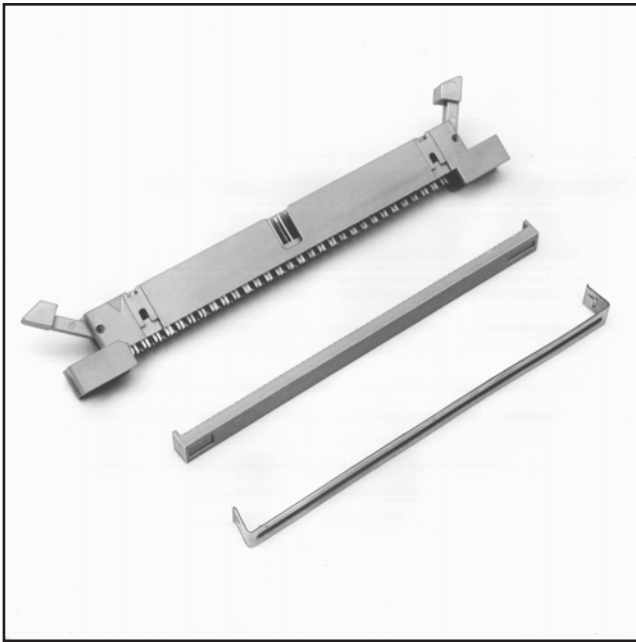

- Shrouded to protect against physical and chemical pin damage
- Open or closed end covers available
- Optional ejector latches
- Accepts flat cable or discrete wire
- Military (with 3518 polarizing key) and centerbump polarization available
- Optional mounting flanges
- Optional metal strain relief
- RoHS Compliant. See the Regulatory Information Appendix (RIA) in the "RoHS Compliance" section of www.3Mconnectors.com for compliance information (RIA E1 & C1 apply)

Date Modified: March 21, 2012

TS-0086-C
Sheet 1 of 4

Physical

Insulator:

Material: Glass Filled Polyester (PBT)

Flammability: UL 94V-0

Color: Gray

Contact:

Material: Copper Alloy

Plating:

Underplating and U-Slot: 100 μ" [2.54 μm] Nickel

Wiping Area: 30 μ" [0.76 μm] Gold

Wire Accommodation: 26 and 28 AWG Solid and Stranded

Marking: 3M Logo, Part Identification Number, and Contact Position Numbers

Electrical

Current Rating: 1 A

Insulation Resistance: $> 1 \times 10^9 \Omega$ at 500 V_{DC}

Withstanding Voltage: 1,000 V_{RMS} at Sea Level

Environmental

Temperature Rating: -55°C to +105°C

UL File No.: E68080

3M

Electronic Solutions Division
Interconnect Solutions
<http://www.3Mconnectors.com>

3M is a trademark of 3M Company.
For technical, sales or ordering information call
800-225-5373

3M™ Wiremount Plug

.100" x .100" Connector for .050" Pitch Cable

4600 Series

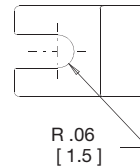
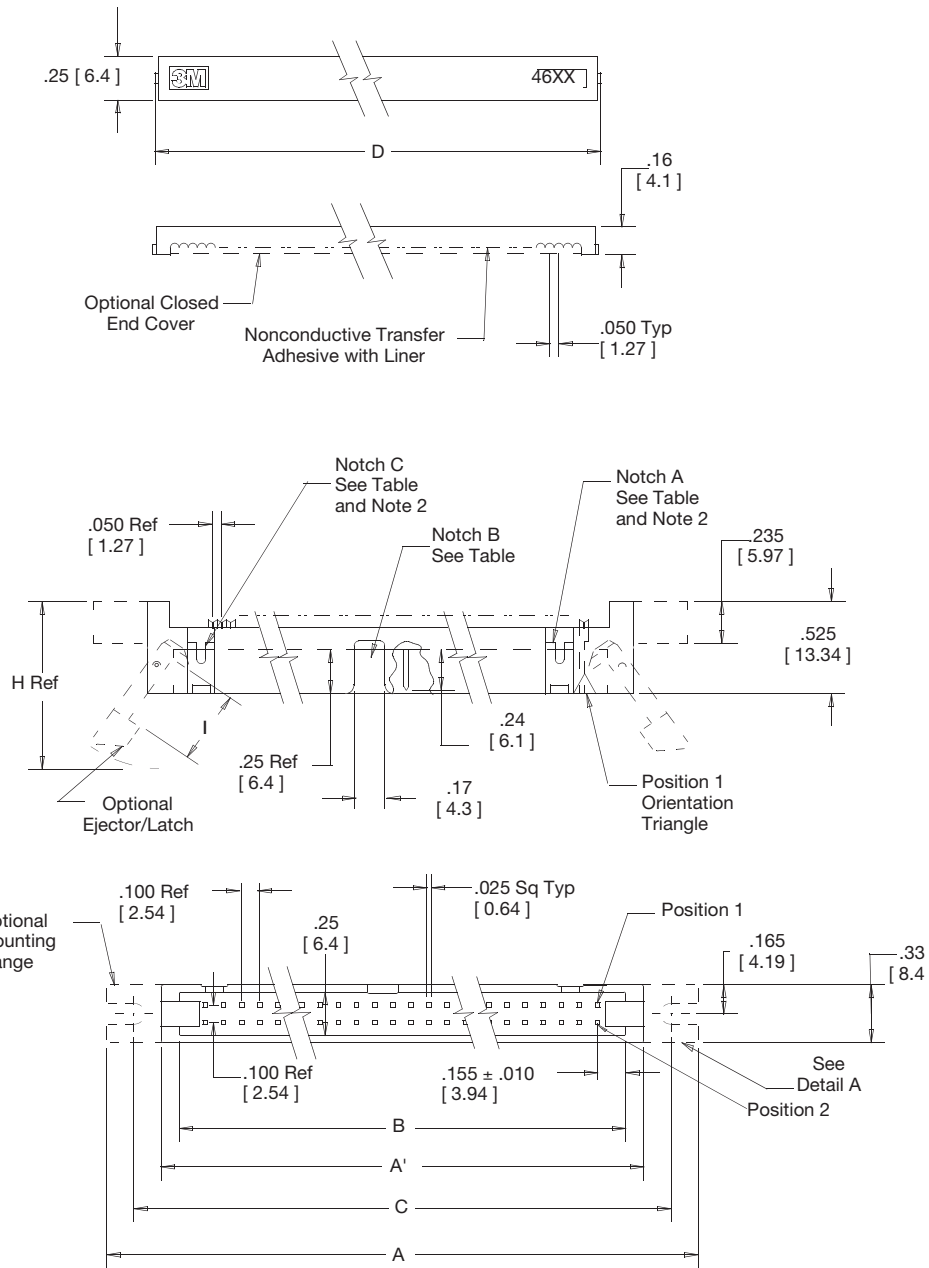

Slotted Mounting Flange
46XX-XXX0

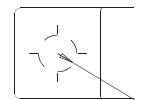

#4-40 x .14 [3.6] Long
Threaded Insert
Torque Spec: 3-5 in/lb

Threaded Mounting Flange
46XX-XXX5
Detail A

Tolerance Unless Noted			
	.0	.0	.000
inch	±.1	±.01	±.005

[] Dimensions for Reference Only



Ordering Information

46XX - XXXX

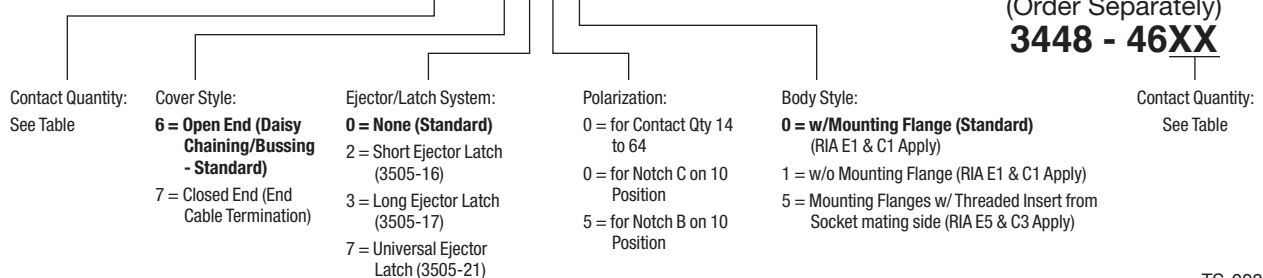

Strain Relief (Order Separately) 3448 - 46XX

Assembly tools: 3M™ Press, 3640 (or equivalent) ; 3M™ Locator Plate, 3443-96; 3M™ Platen, 3442-9

TS-0086-C
Sheet 2 of 4

3M™ Wiremount Plug

.100" x .100" Connector for .050" Pitch Cable

4600 Series

Pin Qty	Dimensions						Polarizing Notches Provided
	A	A'	B	C	D	E	
10	1.50 [38.1]	0.90 [22.9]	0.71 [18.0]	1.20 [30.5]	0.77 [19.6]	0.85 [21.6]	B or C (See Note 1)
14	1.70 [43.2]	1.10 [27.9]	0.91 [23.1]	1.40 [35.6]	0.97 [24.6]	1.05 [26.7]	BC
16	1.80 [45.7]	1.20 [30.5]	1.01 [25.7]	1.50 [38.1]	1.07 [27.2]	1.15 [29.2]	ABC
20	2.00 [50.8]	1.40 [35.6]	1.21 [30.7]	1.70 [43.2]	1.27 [32.3]	1.35 [34.3]	ABC
24	2.20 [55.9]	1.60 [40.6]	1.41 [35.8]	1.90 [48.3]	1.47 [37.3]	1.55 [41.9]	ABC
26	2.30 [58.4]	1.70 [43.2]	1.51 [38.4]	2.00 [50.8]	1.57 [39.9]	1.65 [46.9]	ABC
30	2.50 [63.5]	1.90 [48.3]	1.71 [43.4]	2.20 [55.9]	1.77 [45.0]	1.85 [47.1]	ABC
34	2.70 [68.6]	2.10 [53.3]	1.91 [48.5]	2.40 [61.0]	1.97 [50.0]	2.05 [52.1]	ABC
36	2.80 [71.1]	2.20 [55.9]	2.01 [51.1]	2.50 [63.5]	2.07 [52.6]	2.15 [54.6]	ABC
40	3.00 [76.2]	2.40 [61.0]	2.21 [56.1]	2.70 [68.6]	2.27 [57.7]	2.35 [59.7]	ABC
50	3.50 [88.9]	2.90 [73.7]	2.71 [68.8]	3.20 [81.3]	2.77 [70.4]	2.85 [72.4]	ABC
60	4.00 [101.6]	3.40 [86.4]	3.21 [81.5]	3.70 [94.0]	3.27 [83.1]	3.35 [85.1]	ABC
64	4.20 [106.7]	3.60 [91.4]	3.41 [86.6]	3.90 [99.1]	3.47 [88.1]	3.55 [90.2]	ABC

Ejector/Latch Option	Part Number	Dimensions			
		F	G	H	I
Short	3505-16	.335 [8.51]	.726 [18.44]	0.92 [23.4]	.41 [10.4]
Long	3505-17	.484 [12.29]	.875 [22.23]	1.07 [27.2]	.56 [14.2]
Universal	3505-21	.484 [12.29]	.809 [20.55]	1.01 [25.65]	.56 [14.2]

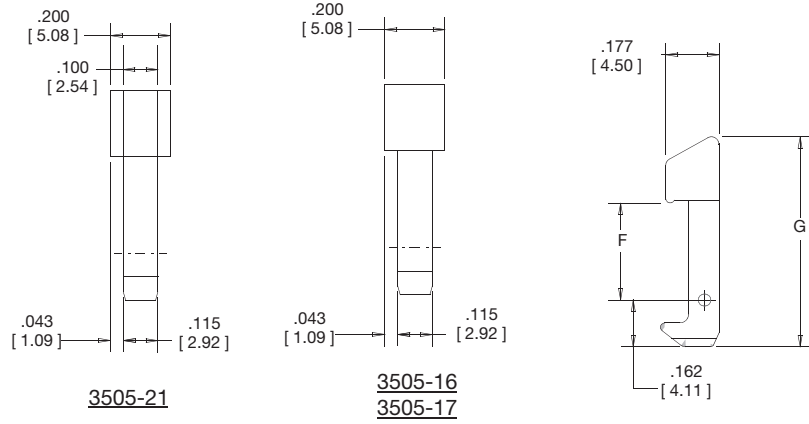

Notes:
The distance from the strain relief to the connector is equal to .04 [1.0] plus the cable thickness.

TS-0086-C
Sheet 3 of 4

3M™ Wiremount Plug

.100" × .100" Connector for .050" Pitch Cable

4600 Series

Table 3

Contact Quantity	3M Part Number Series	Dimension A	Dimension B
10	4610	1.200 [30.48]	0.945 [24.00]
14	4614	1.400 [35.56]	1.145 [29.08]
16	4616	1.500 [38.10]	1.245 [31.62]
20	4620	1.700 [43.18]	1.445 [36.70]
24	4624	1.900 [48.26]	1.645 [41.78]
26	4626	2.000 [50.80]	1.745 [44.32]
30	4630	2.200 [55.88]	1.945 [49.40]
34	4634	2.400 [60.96]	2.145 [54.48]
36	4636	2.500 [63.50]	2.245 [57.02]
40	4640	2.700 [68.58]	2.445 [62.10]
50	4650	3.200 [81.28]	2.945 [74.80]
60	4660	3.700 [93.98]	3.445 [87.50]
64	4664	3.900 [99.06]	3.645 [92.58]



Rear Mount Panel Cutout

Notes:

1. Accepts #4 pan head machine screw.
2. For a rear mount plug connector with Ejector/Latches the recommended maximum panel thickness is .125 [3.18].
3. Without polarizing tabs .340 [8.64].

TS-0086-C
Sheet 4 of 4

3M is a trademark of 3M Company.

Important Notice

All statements, technical information, and recommendations related to 3M's products are based on information believed to be reliable, but the accuracy or completeness is not guaranteed. Before using this product, you must evaluate it and determine if it is suitable for your intended application. You assume all risks and liability associated with such use. Any statements related to the product which are not contained in 3M's current publications, or any contrary statements contained on your purchase order shall have no force or effect unless expressly agreed upon, in writing, by an authorized officer of 3M.

Warranty; Limited Remedy; Limited Liability.

This product will be free from defects in material and manufacture for a period of one (1) year from the time of purchase. **3M MAKES NO OTHER WARRANTIES INCLUDING, BUT NOT LIMITED TO, ANY IMPLIED WARRANTY OF MERCHANTABILITY OR FITNESS FOR A PARTICULAR PURPOSE.** If this product is defective within the warranty period stated above, your exclusive remedy shall be, at 3M's option, to replace or repair the 3M product or refund the purchase price of the 3M product. **Except where prohibited by law, 3M will not be liable for any indirect, special, incidental or consequential loss or damage arising from this 3M product, regardless of the legal theory asserted.**



3M Electronics Solutions Division

6801 River Place Blvd.
Austin, TX 78726-9000
U.S.A.
1-800-225-5373
www.3Mconnectors.com

Please recycle. Printed in USA.
© 3M 2012. All rights reserved.
RIA-2217B-E



Компания «ЭлектроПласт» предлагает заключение долгосрочных отношений при поставках импортных электронных компонентов на взаимовыгодных условиях!

Наши преимущества:

- Оперативные поставки широкого спектра электронных компонентов отечественного и импортного производства напрямую от производителей и с крупнейших мировых складов;
- Поставка более 17-ти миллионов наименований электронных компонентов;
- Поставка сложных, дефицитных, либо снятых с производства позиций;
- Оперативные сроки поставки под заказ (от 5 рабочих дней);
- Экспресс доставка в любую точку России;
- Техническая поддержка проекта, помощь в подборе аналогов, поставка прототипов;
- Система менеджмента качества сертифицирована по Международному стандарту ISO 9001;
- Лицензия ФСБ на осуществление работ с использованием сведений, составляющих государственную тайну;
- Поставка специализированных компонентов (Xilinx, Altera, Analog Devices, Intersil, Interpoint, Microsemi, Aeroflex, Peregrine, Syfer, Eurofarad, Texas Instrument, Miteq, Cobham, E2V, MA-COM, Hittite, Mini-Circuits, General Dynamics и др.);

Помимо этого, одним из направлений компании «ЭлектроПласт» является направление «Источники питания». Мы предлагаем Вам помощь Конструкторского отдела:

- Подбор оптимального решения, техническое обоснование при выборе компонента;
- Подбор аналогов;
- Консультации по применению компонента;
- Поставка образцов и прототипов;
- Техническая поддержка проекта;
- Защита от снятия компонента с производства.



Как с нами связаться

Телефон: 8 (812) 309 58 32 (многоканальный)

Факс: 8 (812) 320-02-42

Электронная почта: org@eplast1.ru

Адрес: 198099, г. Санкт-Петербург, ул. Калинина, дом 2, корпус 4, литера А.