

Tous droits strictement reserves. Reproduction ou communication a des tiers interdite sous quelque forme que ce soit sans autorisation écrite du propriétaire. Propriete de c FCI. Droits de reproduction FCI.

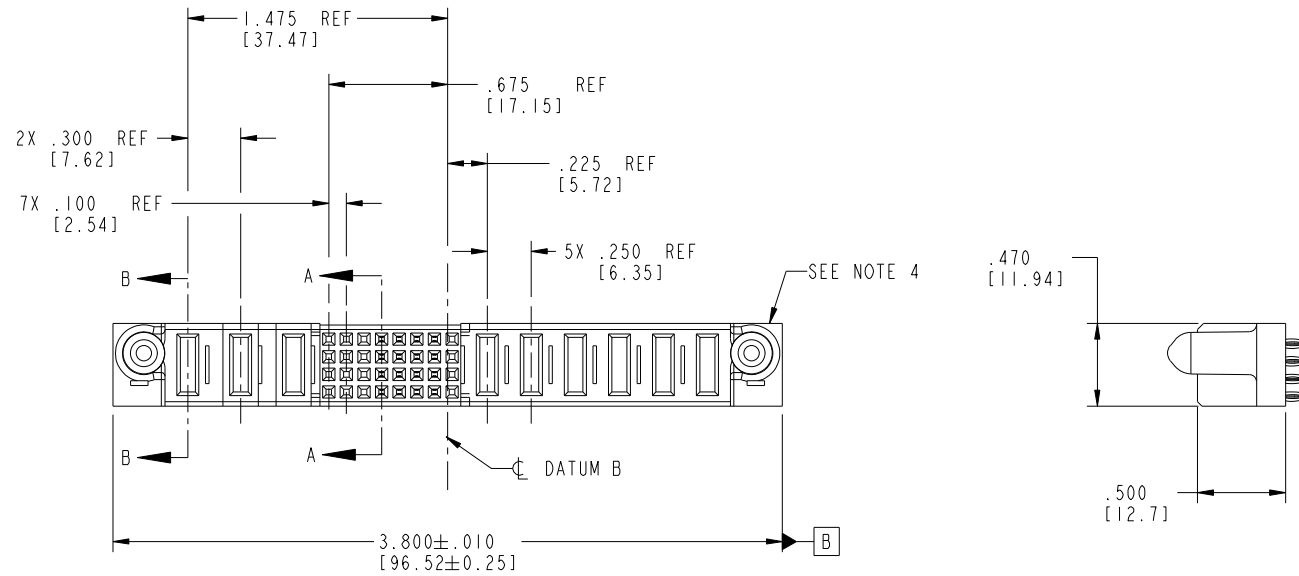

All rights strictly reserved. Reproduction or issue to third parties in any form whatever is not permitted without written authority from the proprietor. Property of FCI. Copyright FCI.

PRODUCT NO.	ROWS	POWER			SIGNAL							POWER					E1											
		E2	P9	P8	P7	8	7	6	5	4	3	2	1	P6	P5	P4		P3	P2	P1								
51936-003-- NOTE:3	D C B A		PF	PF	PC	X	X	X	F	F	F	F	X	X	X	X	F	F	F	F	X	PF	PF	PF	PF	PF	PF	



CODE	DIM "M" ±.010[0.25]	CONTACT TYPE
F	N/A [N/A]	SIGNAL
PC	.042 [1.07]	POWER
PF	.092 [2.34]	POWER
X	OMITTED	OMITTED

mat'l code		SEE NOTE 2		tolerances unless otherwise specified		CUSTOMER				www.fciconnect.com	
ltr	ecn no.	dr	date	linear	.XX±.01/0.X±0.3	COPY		projection		title	
A	V20789	JWS	04-23-02		.XXX±.005/0.XX±0.13	INCH/MM				6P + 32S + 3P VERTICAL PRESS FIT RECEPT	
B	DG08-0273	WD	12/22/08	angles	.XXX±.0020/0.XXX±0.051	scale		product family		code	
				dr	0°±2°	1:1		PwrBlade		213	
				enr	J. SHAFFER 04-23-02			size		sheet	
				chr	J. ALLISON 04-23-02			dwg no		1 of 4	
				appd	J. ALLISON 04-23-02			A		51936-003	
sheet index	revision	B	B	B	B						
	sheet	1	2	3	4						

cage code 22526

Tous droits strictement reserves. Reproduction ou communication a des tiers interdite sous quelque forme que ce soit sans autorisation écrite du propriétaire. Propriete de c FCI. Droits de reproduction FCI.



All rights strictly reserved. Reproduction or issue to third parties in any form whatsoever is not permitted without written authority from the proprietor. Property of FCI. Copyright FCI.

PRODUCT NUMBER
51936-003__
NOTE: 3

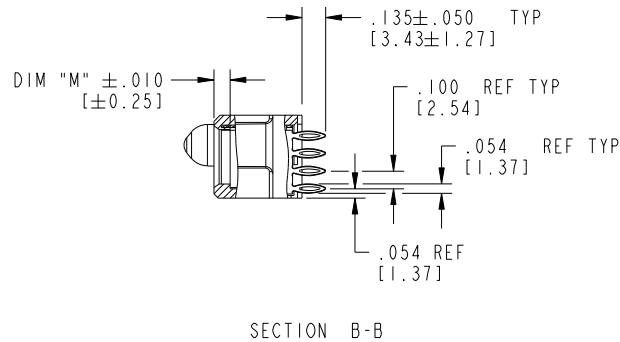
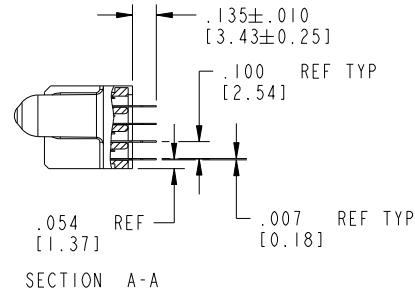

mat'l code		SEE NOTE 2		tolerances unless otherwise specified		CUSTOMER		 www.fciconnect.com	
ltr	ecn no.	dr	date	linear	.XX±.01/0.X±0.3	COPY		title	
B					.XXX±.005/0.XX±0.13	projection		6P + 32S + 3P	
				angles	.XXX±.002/0.XXX±0.051			VERTICAL PRESS FIT RECEIPT	
					0°±2°	INCH/MM		product family	
		dr	J. SHAFFER	04-23-02		scale		PwrBlade	
		enr	J. ALLISON	04-23-02		1:1		code	
		chr	J. ALLISON	04-23-02		A		213	
		appd	J. ALLISON	04-23-02		51936-003		sheet	
								2	
sheet index	revision sheet							B	

Pro/E

cage code 22526

Tous droits strictement reserves. Reproduction ou communication a des tiers interdite sous quelque forme que ce soit sans autorisation écrite du propriétaire. Propriete de c FCI. Droits de reproduction FCI.



All rights strictly reserved. Reproduction or issue to third parties in any form whatsoever is not permitted without written authority from the proprietor. Property of FCI. Copyright FCI.

PRODUCT NUMBER
51936-003__
NOTE: 3

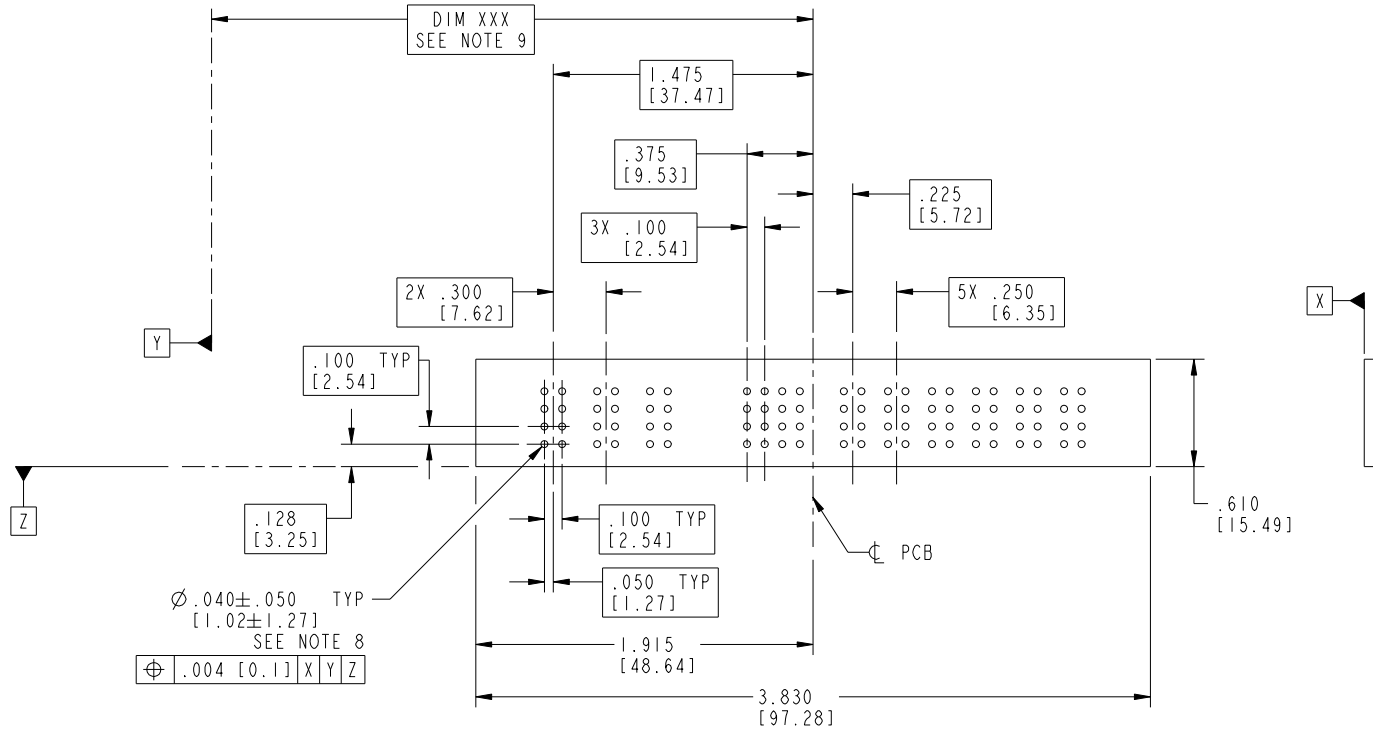

SEE NOTE 8
 $\oplus .004 [0.1] X | Y | Z$

mat'l code		SEE NOTE 2		tolerances unless otherwise specified		CUSTOMER		 www.fciconnect.com	
ltr	ecn no.	dr	date	linear	.XX±.01/0.X±0.3	COPY		title	
B					.XXX±.005/0.XX±0.13	projection		6P + 32S + 3P	
				angles	.XXX±.002/0.XXX±0.051			VERTICAL PRESS FIT RECEIPT	
				dr	0°±2°	INCH/MM		product family	
				enr	J. SHAFFER 04-23-02	scale		PwrBlade	
				chr	J. ALLISON 04-23-02	1:1		code	
				appd	J. ALLISON 04-23-02	size		213	
sheet index		revision sheet				dwg no		3	
						A		51936-003	
						cage code		22526	

Pro/E

cage code 22526

Tous droits strictement reserves. Reproduction ou communication a des tiers interdite sous quelque forme que ce soit sans autorisation écrite du propriétaire. Propriete de c FCI. Droits de reproduction FCI.



All rights strictly reserved. Reproduction or issue to third parties in any form whatever is not permitted without written authority from the proprietor. Property of FCI. Copyright FCI.

PRODUCT NUMBER
51936-003__
NOTE: 3

NOTES:

1. DIMENSIONS AND TOLERANCES ARE IN ACCORDANCE WITH ASME Y14.5M, 1994 UNLESS OTHERWISE SPECIFIED.

CONNECTORS NOTES:

2. HOUSING MATERIAL: UL 94 V-0 GLASS FILLED HIGH TEMP THERMO PLASTIC
POWER CONTACT MATERIAL: COPPER ALLOY
SIGNAL PIN MATERIAL: COPPER ALLOY

3. SEE ITEM 7 & 8 IN PRINT 10064183 FOR PLATING SPEC OF 51936-003 AND 51936-003LF RESPECTIVELY.

4. "MANUFACTURER" NAME, P/N, AND DATE CODE TO APPEAR ON THIS SURFACE.

5. PRODUCT SPECIFICATION GS-12-149.

PCB - NOTES:

6. ALL HOLE DIAMETERS ARE FINISHED HOLE SIZE.

7. HOLD DOWN THROUGH HOLES ARE UNPLATED.

8. $\varnothing .0453 \pm 0.0010$ [1.151 ± 0.025] DRILLED HOLES PLATED WITH 0.0003 [0.008] MIN SnPb OVER $.001$ [0.03] TO $.003$ [0.08] Cu PLATING TO ACHIEVE $\varnothing .040 \pm .003$ [$1.02 \pm .07$] HOLE.

9. "DIM XXX" TO BE DETERMINED BY THE CUSTOMER.

10. A Δ SYMBOL WILL BE NEXT TO ANY DIMENSION, VIEW, OR NOTE WHICH HAS BEEN MODIFIED WITH THE CURRENT DRAWING REVISION.

mat'l code		SEE NOTE 2		tolerances unless otherwise specified		CUSTOMER				www.fciconnect.com	
ltr	ecn no.	dr	date	linear	$.XX \pm .01 / 0.X \pm 0.3$	COPY		title			
B					$.XXX \pm .005 / 0.XX \pm 0.13$	projection		6P + 32S + 3P			
				angles	$.XXX \pm .0020 / 0.XXX \pm 0.051$			VERTICAL PRESS FIT RECEIPT			
				dr	$0^{\circ} \pm 2^{\circ}$	INCH/MM		product family		PwrBlade	code
				enrg	J. SHAFFER 04-23-02	scale		size		dwg no	213
				chr	J. ALLISON 04-23-02	1:1		A		51936-003	sheet
				appd	J. ALLISON 04-23-02						4
sheet index	revision sheet										

1 | 2

Pro/E

3 |

cage code 22526

4



Компания «ЭлектроПласт» предлагает заключение долгосрочных отношений при поставках импортных электронных компонентов на взаимовыгодных условиях!

Наши преимущества:

- Оперативные поставки широкого спектра электронных компонентов отечественного и импортного производства напрямую от производителей и с крупнейших мировых складов;
- Поставка более 17-ти миллионов наименований электронных компонентов;
- Поставка сложных, дефицитных, либо снятых с производства позиций;
- Оперативные сроки поставки под заказ (от 5 рабочих дней);
- Экспресс доставка в любую точку России;
- Техническая поддержка проекта, помощь в подборе аналогов, поставка прототипов;
- Система менеджмента качества сертифицирована по Международному стандарту ISO 9001;
- Лицензия ФСБ на осуществление работ с использованием сведений, составляющих государственную тайну;
- Поставка специализированных компонентов (Xilinx, Altera, Analog Devices, Intersil, Interpoint, Microsemi, Aeroflex, Peregrine, Syfer, Eurofarad, Texas Instrument, Miteq, Cobham, E2V, MA-COM, Hittite, Mini-Circuits, General Dynamics и др.);

Помимо этого, одним из направлений компании «ЭлектроПласт» является направление «Источники питания». Мы предлагаем Вам помощь Конструкторского отдела:

- Подбор оптимального решения, техническое обоснование при выборе компонента;
- Подбор аналогов;
- Консультации по применению компонента;
- Поставка образцов и прототипов;
- Техническая поддержка проекта;
- Защита от снятия компонента с производства.



Как с нами связаться

Телефон: 8 (812) 309 58 32 (многоканальный)

Факс: 8 (812) 320-02-42

Электронная почта: org@eplast1.ru

Адрес: 198099, г. Санкт-Петербург, ул. Калинина, дом 2, корпус 4, литера А.