

# LC75834E, LC75834W, LC75834JE

## 1/4-Duty General-Purpose LCD Driver



ON Semiconductor®

www.onsemi.com

### Overview

The LC75834E, LC75834W, and LC75834JE are 1/4 duty general-purpose LCD drivers that can be used for frequency display in electronic tuners under the control of a microcontroller. The LC75834E and LC75834W can drive an LCD with up to 136 segments directly, the LC75834JE can drive an LCD with up to 120 segments directly. The LC75834E and LC75834W and LC75834JE can also control up to 8 general-purpose output ports. Since the LC75834E, LC75834W, and LC75834JE use separate power supply systems for the LCD drive block and the logic block, the LCD driver block power-supply voltage can be set to any voltage in the range 2.7 to 6.0 V, regardless of the logic block power-supply voltage.

### Features

- Supports both 1/4 duty 1/2 bias and 1/4 duty 1/3 bias LCD drive under serial data control.
  - LC75834E, LC75834W : up to 136 segments
  - LC75834JE : up to 120 segments(without the S9, S18, S27, S34 segment output pins from the LC75834E, LC75834W)
- Serial data input supports CCB\* format communication with the system controller.
- Serial data control of the power-saving mode based backup function and all the segments forced off function
- Serial data control of switching between the segment output port and the general-purpose output port functions
- High generality, since display data is displayed directly without decoder intervention.
- Independent  $V_{LCD}$  for the LCD driver block ( $V_{LCD}$  can be set to any voltage in the range 2.7 to 6.0 V, regardless of the logic block power-supply voltage.)
- The  $\overline{INH}$  pin can force the display to the off state.
- RC oscillator circuit

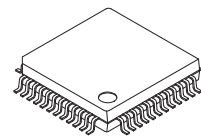

PQFP48 14x14 / QIP48E  
[LC75834E]

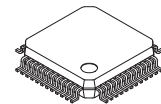

SPQFP48 7x7 / SQFP48  
[LC75834W]

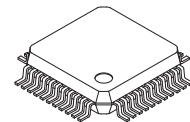

PQFP44 10x10 / QIP44M  
[LC75834JE]

\* Computer Control Bus (CCB) is an ON Semiconductor's original bus format and the bus addresses are controlled by ON Semiconductor.

### ORDERING INFORMATION

See detailed ordering and shipping information on page 22 of this data sheet.

# LC75834E, LC75834W, LC75834JE

## Specifications

**Absolute Maximum Ratings** at  $T_a = 25^\circ\text{C}$ ,  $V_{SS} = 0\text{ V}$

Parameter	Symbol	Conditions	Ratings	Unit
Maximum supply voltage	$V_{DD\text{ max}}$	$V_{DD}$	-0.3 to +7.0	V
	$V_{LCD\text{ max}}$	$V_{LCD}$	-0.3 to +7.0	V
Input voltage	$V_{IN\ 1}$	CE, CL, DI, $\overline{\text{INH}}$	-0.3 to +7.0	V
	$V_{IN\ 2}$	OSC	-0.3 to $V_{DD} + 0.3$	V
	$V_{IN\ 3}$	$V_{LCD\ 1}$ , $V_{LCD\ 2}$	-0.3 to $V_{LCD} + 0.3$	V
Output voltage	$V_{OUT\ 1}$	OSC	-0.3 to $V_{DD} + 0.3$	V
	$V_{OUT\ 2}$	S1 to S34, COM1 to COM4, P1 to P8	-0.3 to $V_{LCD} + 0.3$	V
Output current	$I_{OUT\ 1}$	S1 to S34	300	$\mu\text{A}$
	$I_{OUT\ 2}$	COM1 to COM4	3	mA
	$I_{OUT\ 3}$	P1 to P8	5	mA
Allowable power dissipation	$P_d\text{ max}$	$T_a = 85^\circ\text{C}$	150	mW
Operating temperature	$T_{opr}$		-40 to +85	$^\circ\text{C}$
Storage temperature	$T_{stg}$		-55 to +125	$^\circ\text{C}$

Note: The LC75834JE do not have the S9, S18, S27 S34 output pins.

Stresses exceeding those listed in the Maximum Ratings table may damage the device. If any of these limits are exceeded, device functionality should not be assumed, damage may occur and reliability may be affected.

**Allowable Operating Ranges** at  $T_a = -40$  to  $+85^\circ\text{C}$ ,  $V_{SS} = 0\text{ V}$

Parameter	Symbol	Conditions	Ratings			Unit
			min	typ	max	
Supply voltage	$V_{DD}$	$V_{DD}$	2.7		6.0	V
	$V_{LCD}$	$V_{LCD}$	2.7		6.0	V
Input voltage	$V_{LCD1}$	$V_{LCD1}$		$2/3 V_{LCD}$	$V_{LCD}$	V
	$V_{LCD2}$	$V_{LCD2}$		$1/3 V_{LCD}$	$V_{LCD}$	V
Input high level voltage	$V_{IH}$	CE, CL, DI, $\overline{\text{INH}}$	$0.8 V_{DD}$		6.0	V
Input low level voltage	$V_{IL}$	CE, CL, DI, $\overline{\text{INH}}$	0		$0.2 V_{DD}$	V
Recommended external resistance	$R_{OSC}$	OSC		43		$k\Omega$
Recommended external capacitance	$C_{OSC}$	OSC		680		pF
Guaranteed oscillation range	$f_{OSC}$	OSC	25	50	100	kHz
Data setup time	$t_{ds}$	CL, DI: Figure 2	160			ns
Data hold time	$t_{dh}$	CL, DI: Figure 2	160			ns
CE wait time	$t_{cp}$	CE, CL: Figure 2	160			ns
CE setup time	$t_{cs}$	CE, CL: Figure 2	160			ns
CE hold time	$t_{ch}$	CE, CL: Figure 2	160			ns
High level clock pulse width	$t_{\theta H}$	CL: Figure 2	160			ns
Low level clock pulse width	$t_{\theta L}$	CL: Figure 2	160			ns
Rise time	$t_r$	CE, CL, DI: Figure 2		160		ns
Fall time	$t_f$	CE, CL, DI: Figure 2		160		ns
$\overline{\text{INH}}$ switching time	$t_c$	$\overline{\text{INH}}$ , CE: Figure 3	10			$\mu\text{s}$

Functional operation above the stresses listed in the Recommended Operating Ranges is not implied. Extended exposure to stresses beyond the Recommended Operating Ranges limits may affect device reliability.

# LC75834E, LC75834W, LC75834JE

## Electrical Characteristics for the Allowable Operating Ranges

Parameter	Symbol	Conditions	Ratings			Unit
			min	typ	max	
Hysteresis	$V_H$	CE, CL, DI, $\overline{\text{INH}}$		0.1 $V_{DD}$		V
Input high level current	$I_{IH}$	CE, CL, DI, $\overline{\text{INH}}$ ; $V_I = 6.0\text{ V}$			5.0	$\mu\text{A}$
Input low level current	$I_{IL}$	CE, CL, DI, $\overline{\text{INH}}$ ; $V_I = 0\text{ V}$	-5.0			$\mu\text{A}$
Output high level voltage	$V_{OH1}$	S1 to S34; $I_O = -20\ \mu\text{A}$	$V_{LCD} - 0.9$			V
	$V_{OH2}$	COM1 to COM4; $I_O = -100\ \mu\text{A}$	$V_{LCD} - 0.9$			V
	$V_{OH3}$	P1 to P8; $I_O = -1\ \text{mA}$	$V_{LCD} - 0.9$			V
Output low level voltage	$V_{OL1}$	S1 to S34; $I_O = 20\ \mu\text{A}$			0.9	V
	$V_{OL2}$	COM1 to COM4; $I_O = 100\ \mu\text{A}$			0.9	V
	$V_{OL3}$	P1 to P8; $I_O = 1\ \text{mA}$			0.9	V
Output middle level voltage*1	$V_{MID1}$	COM1 to COM4; 1/2 bias, $I_O = \pm 100\ \mu\text{A}$	$1/2 V_{LCD} - 0.9$		$1/2 V_{LCD} + 0.9$	V
	$V_{MID2}$	S1 to S34; 1/3 bias, $I_O = \pm 20\ \mu\text{A}$	$2/3 V_{LCD} - 0.9$		$2/3 V_{LCD} + 0.9$	V
	$V_{MID3}$	S1 to S34; 1/3 bias, $I_O = \pm 20\ \mu\text{A}$	$1/3 V_{LCD} - 0.9$		$1/3 V_{LCD} + 0.9$	V
	$V_{MID4}$	COM1 to COM4; 1/3 bias, $I_O = \pm 100\ \mu\text{A}$	$2/3 V_{LCD} - 0.9$		$2/3 V_{LCD} + 0.9$	V
	$V_{MID5}$	COM1 to COM4; 1/3 bias, $I_O = \pm 100\ \mu\text{A}$	$1/3 V_{LCD} - 0.9$		$1/3 V_{LCD} + 0.9$	V
Oscillator frequency	$f_{OSC}$	OSC; $R_{OSC} = 43\ \text{k}\Omega$ , $C_{OSC} = 680\ \text{pF}$	40	50	60	kHz
Current drain	$I_{DD1}$	$V_{DD}$ ; power saving mode			5	$\mu\text{A}$
	$I_{DD2}$	$V_{DD}$ ; $V_{DD} = 6.0\text{ V}$ , output open, $f_{osc} = 50\ \text{kHz}$		230	460	$\mu\text{A}$
	$I_{LCD1}$	$V_{LCD}$ ; power saving mode			5	$\mu\text{A}$
	$I_{LCD2}$	$V_{LCD}$ ; $V_{LCD} = 6.0\text{ V}$ , output open 1/2 bias, $f_{osc} = 50\ \text{kHz}$		100	200	$\mu\text{A}$
	$I_{LCD3}$	$V_{LCD}$ ; $V_{LCD} = 6.0\text{ V}$ , output open 1/3 bias, $f_{osc} = 50\ \text{kHz}$		60	120	$\mu\text{A}$

Note: \*1 Excluding the bias voltage generation divider resistors built in the  $V_{LCD1}$  and  $V_{LCD2}$ . (See Figure 1.)

The LC75834JE do not have the S9, S18, S27, S34 output pins.

Product parametric performance is indicated in the Electrical Characteristics for the listed test conditions, unless otherwise noted. Product performance may not be indicated by the Electrical Characteristics if operated under different conditions.

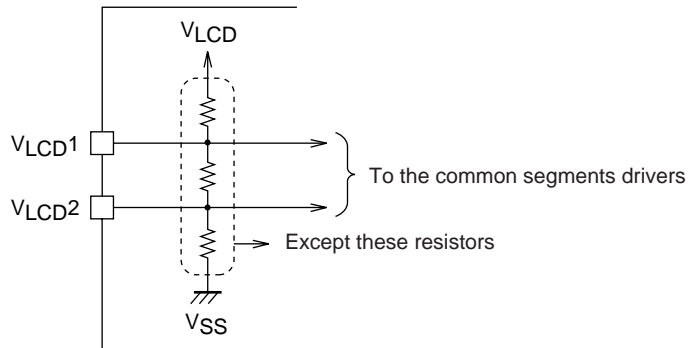
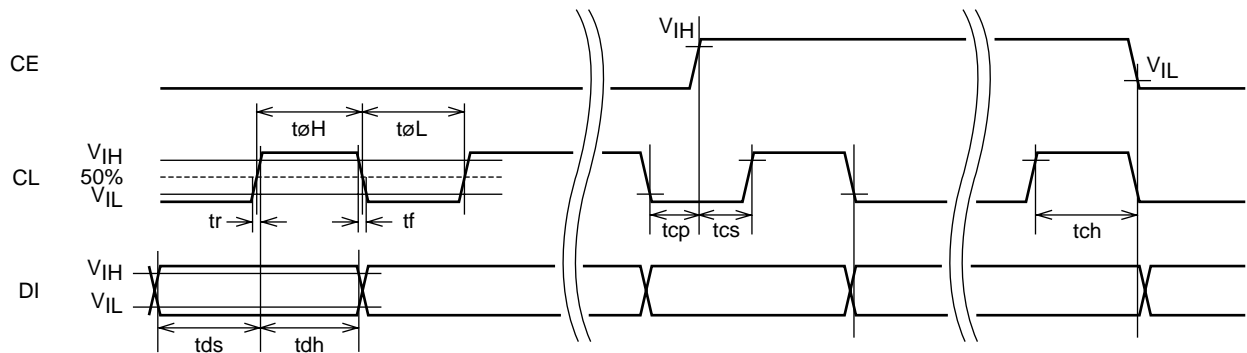

Figure 1

1. When CL is stopped at the low level



2. When CL is stopped at the high level

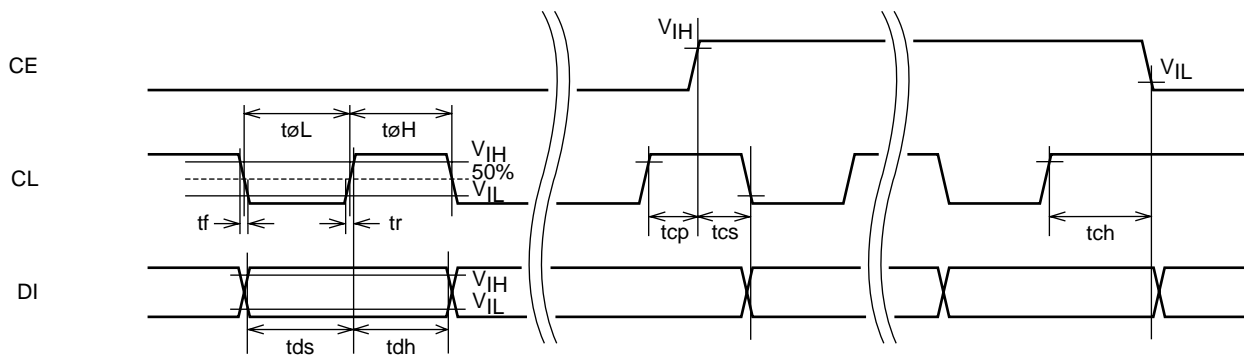
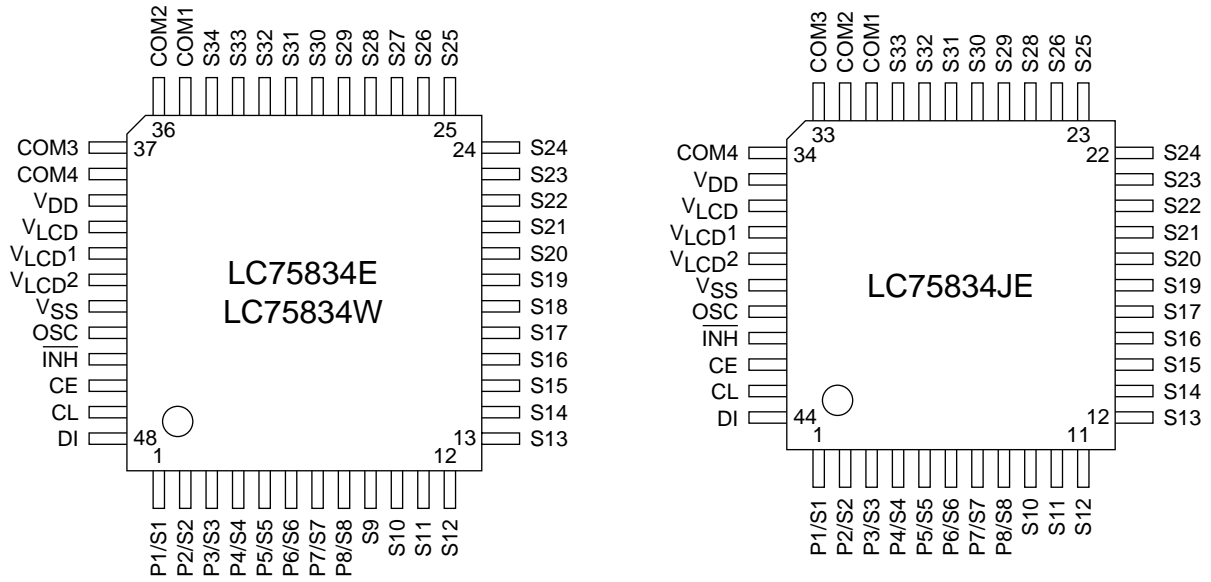
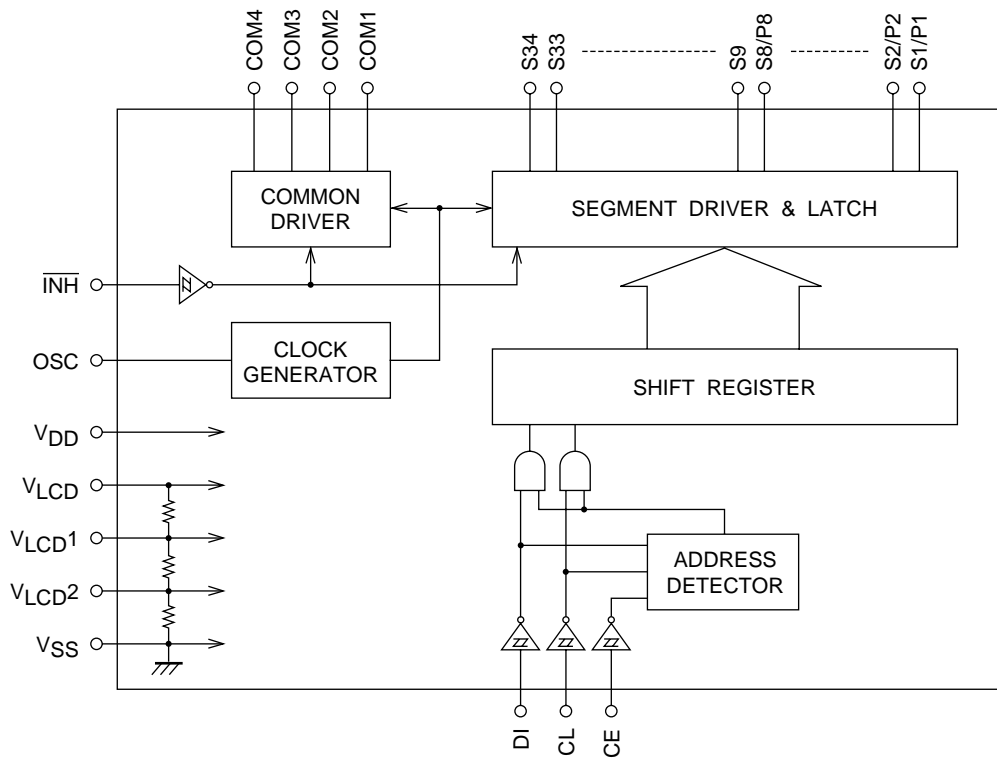

Figure 2

Pin Assignments



Block Diagram



Note: The LC75834JE do not have the S9, S18, S27, S34 output pins.

**LC75834E, 75834W, 75834JE**

**Pin Functions**

Pin	Pin No.		Function	Active	I/O	Handling when unused
	LC75834E, 75834W	LC75834JE				
S1/P1 to S8/P8 S9 to S34	1 to 8 9 to 34	1 to 8 9 to 30	Segment outputs for displaying the display data transferred by serial data input. The pins S1/P1 to S8/P8 can be used as general-purpose output ports when so set up by the control data.	—	O	Open
COM1 COM2 COM3 COM4	35 36 37 38	31 32 33 34	Common driver outputs. The frame frequency $f_O$ is given by: $f_O = (f_{OSC}/512)$ Hz.	—	O	Open
OSC	44	40	Oscillator connection An oscillator circuit is formed by connecting an external resistor and capacitor to this pin.	—	I/O	$V_{DD}$
CE CL DI	46 47 48	42 43 44	Serial data transfer inputs. These pins are connected to the control microprocessor.	H — —	I	GND
$\overline{\text{INH}}$	45	41	Display off control input • $\overline{\text{INH}}$ = low ( $V_{SS}$ ): Off S1/P1 to S8/P8 = Low (These pins are forcible set to the segment output port function and fixed at the $V_{SS}$ level.) S9 to S34 = Low ( $V_{SS}$ ), COM1 to COM4 = Low ( $V_{SS}$ ) • $\overline{\text{INH}}$ = high ( $V_{DD}$ ): On Note that serial data transfers can be performed when the display is forced off by this pin.	L	I	GND
$V_{LCD1}$	41	37	Used to apply the LCD drive 2/3 bias voltage externally. This pin must be connected to $V_{LCD2}$ when 1/2 bias drive is used.	—	I	Open
$V_{LCD2}$	42	38	Used to apply the LCD drive 1/3 bias voltage externally. This pin must be connected to $V_{LCD1}$ when 1/2 bias drive is used.	—	I	Open
$V_{DD}$	39	35	Logic block power supply. Provide a voltage in the range 2.7 to 6.0 V.	—	—	—
$V_{LCD}$	40	36	LCD driver block power supply. Provide a voltage in the range 2.7 to 6.0 V.	—	—	—
$V_{SS}$	43	39	Ground pin. Connect to ground.	—	—	—

Note: The LC75834JE do not have the S9, S18, S27, S34 output pins.

### Serial Data Transfer Format

1. When CL is stopped at the low level

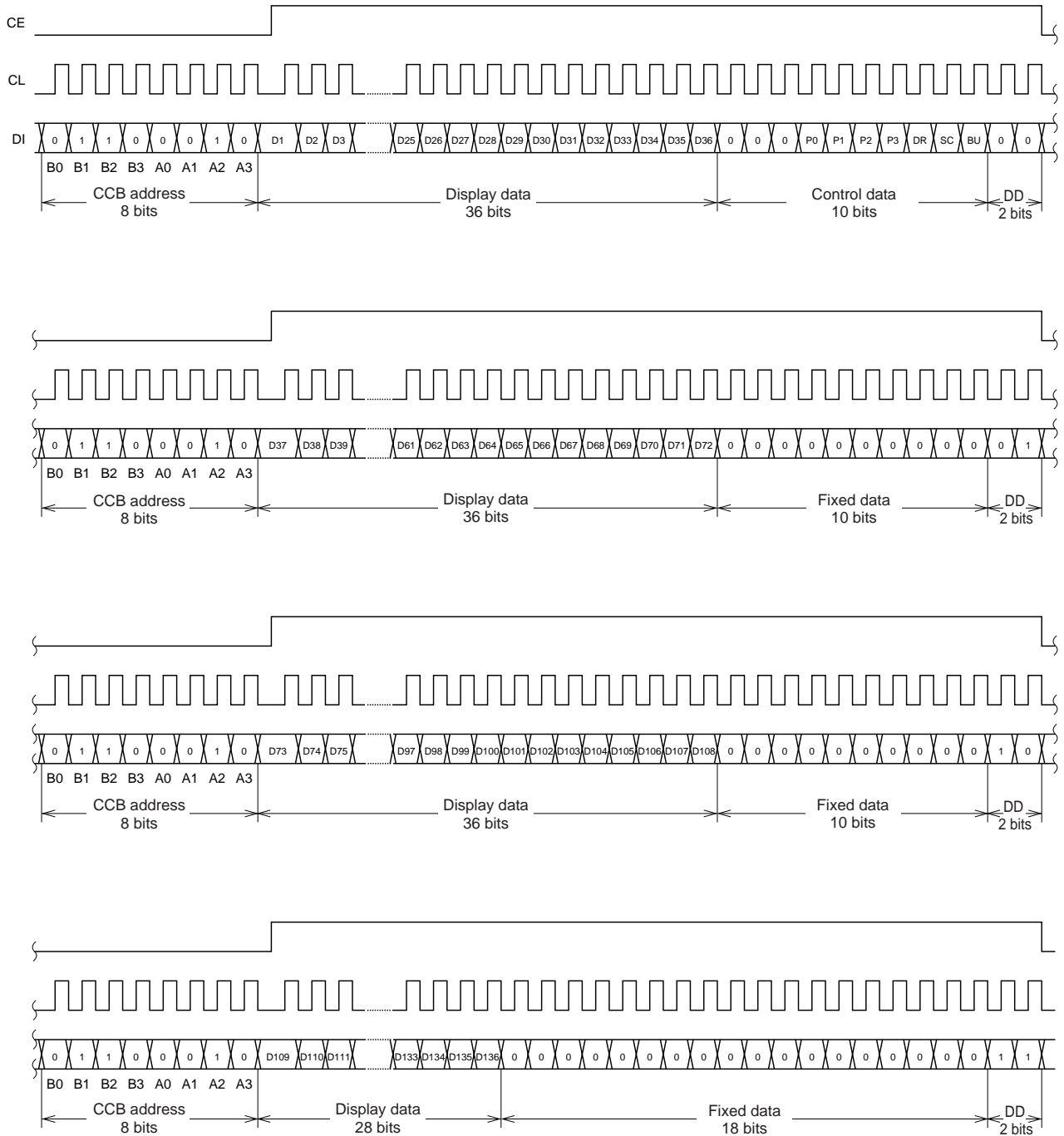

Note: DD ... Direction data

2. When CL is stopped at the high level

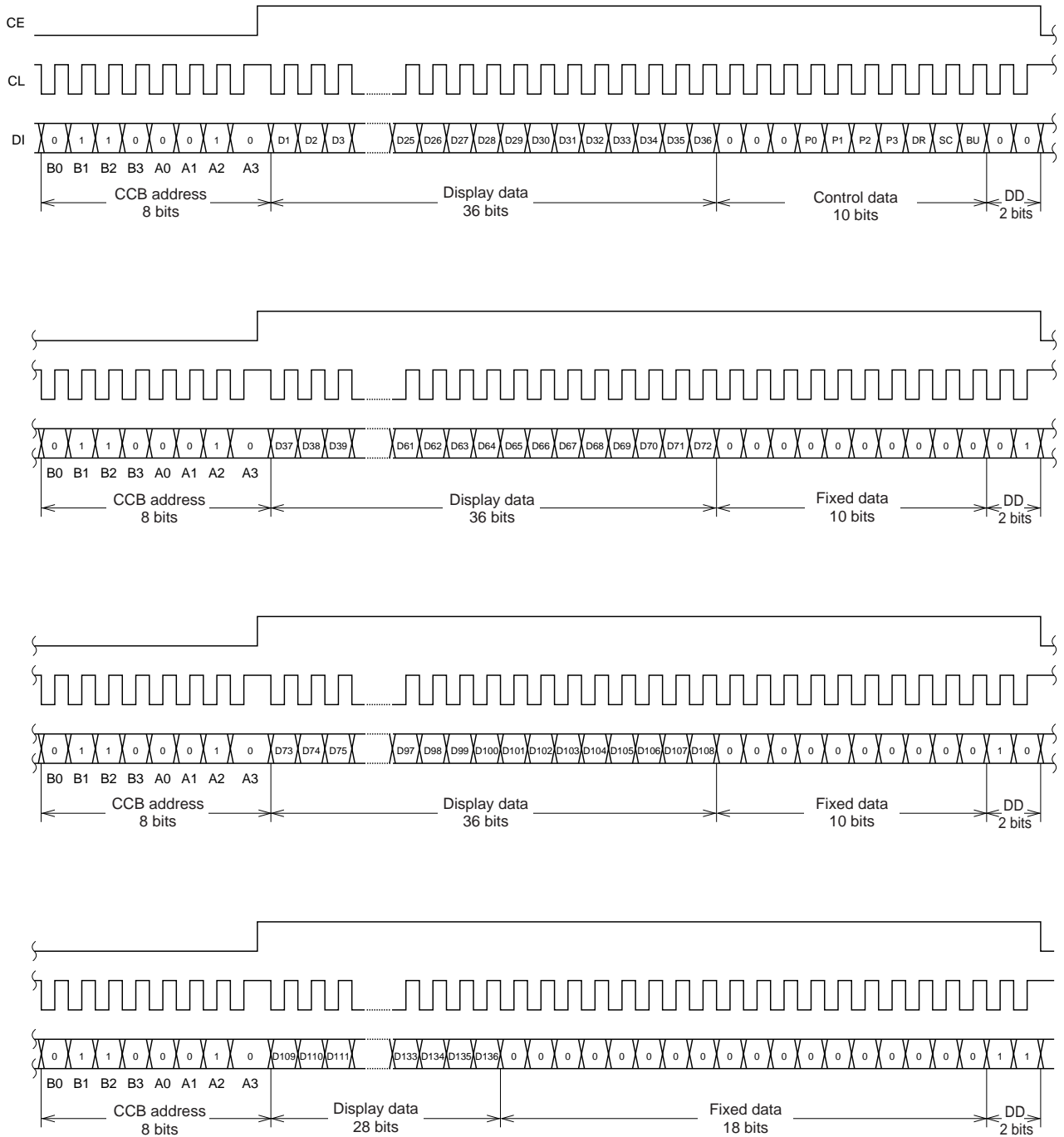

Note: DD ... Direction data

- CCB address.....46H
- D1 to D136.....Display data (At the LC75834JE, the display data D33 to D36, D69 to D72, D105 to D108, D133 to D136 must be set to 0.
- P0 to P3 .....Segment output port/general-purpose output port switching control data
- DR .....1/2 bias drive or 1/3 bias drive switching control data
- SC.....Segments on/off control data
- BU .....Normal mode/power-saving mode control data



### Serial Data Transfer Examples

- At the LC75834E and LC75834W when 109 or more segments are used, at the LC75834JE when 97 or more segments are used, 192 bits of serial data must be sent.



Note: At the LC75834JE, the display data D33 to D36, D69 to D72, D105 to D108, D133 to D136 must be set to 0.

- At the LC75834E and LC75834W when used with less than 109 segments, at the LC75834JE when used with less than 97 segments, transfer either 48 bits, 96 bits or 144 bits of serial data depending on the number of segments used. However, the serial data shown in the figure below (the display data D1 to D36 and the control data) must be sent.

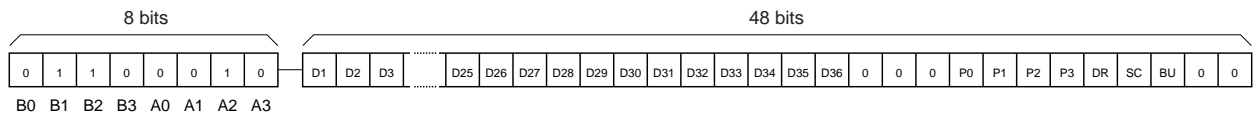

Note: At the LC75834JE, the display data D33 to D36 must be set to 0.

### Control Data Functions

- P0 to P3: Segment output port/general-purpose output port switching control data. These control data bits switch the S1/P1 to S8/P8 output pins between their segment output port and general-purpose output port functions.

Control data				Output pin states							
P0	P1	P2	P3	S1/P1	S2/P2	S3/P3	S4/P4	S5/P5	S6/P6	S7/P7	S8/P8
0	0	0	0	S1	S2	S3	S4	S5	S6	S7	S8
0	0	0	1	P1	S2	S3	S4	S5	S6	S7	S8
0	0	1	0	P1	P2	S3	S4	S5	S6	S7	S8
0	0	1	1	P1	P2	P3	S4	S5	S6	S7	S8
0	1	0	0	P1	P2	P3	P4	S5	S6	S7	S8
0	1	0	1	P1	P2	P3	P4	P5	S6	S7	S8
0	1	1	0	P1	P2	P3	P4	P5	P6	S7	S8
0	1	1	1	P1	P2	P3	P4	P5	P6	P7	S8
1	0	0	0	P1	P2	P3	P4	P5	P6	P7	P8

Note: Sn (n = 1 to 8): Segment output ports  
 Pn (n = 1 to 8): General-purpose output ports

Also note that when the general-purpose output port function is selected, the output pins and the display data will have the correspondences listed in the tables below.

Output pin	Corresponding display data
S1/P1	D1
S2/P2	D5
S3/P3	D9
S4/P4	D13

Output pin	Corresponding display data
S5/P5	D17
S6/P6	D21
S7/P7	D25
S8/P8	D29

For example, if the output pin S4/P4 has the general-purpose output port function selected, it will output a high level ( $V_{LCD}$ ) when the display data D13 is 1, and will output a low level ( $V_{SS}$ ) when D13 is 0.

2. DR: 1/2 bias drive or 1/3 bias drive switching control data  
This control data bit selects either 1/2 bias drive or 1/3 bias drive.

DR	Drive type
0	1/3 bias drive
1	1/2 bias drive

3. SC: Segments on/off control data  
This control data bit controls the on/off state of the segments.

SC	Display state
0	On
1	Off

However, note that when the segments are turned off by setting SC to 1, the segments are turned off by outputting segment off waveforms from the segment output pins.

4. BU: Normal mode/power-saving mode control data  
This control data bit selects either normal mode or power-saving mode.

BU	Mode
0	Normal mode
1	Power saving mode (The OSC pin oscillator is stopped, and the common and segment output pins go to the VSS level. However, the S1/P1 to S8/P8 output pins that are set to be general-purpose output ports by the control data P0 to P3 can be used as general-purpose output ports.)

**Display Data to Segment Output Pin Correspondence**

Segment output pin	COM1	COM2	COM3	COM4
S1/P1	D1	D2	D3	D4
S2/P2	D5	D6	D7	D8
S3/P3	D9	D10	D11	D12
S4/P4	D13	D14	D15	D16
S5/P5	D17	D18	D19	D20
S6/P6	D21	D22	D23	D24
S7/P7	D25	D26	D27	D28
S8/P8	D29	D30	D31	D32
S9	D33	D34	D35	D36
S10	D37	D38	D39	D40
S11	D41	D42	D43	D44
S12	D45	D46	D47	D48
S13	D49	D50	D51	D52
S14	D53	D54	D55	D56
S15	D57	D58	D59	D60
S16	D61	D62	D63	D64
S17	D65	D66	D67	D68

Segment output pin	COM1	COM2	COM3	COM4
S18	D69	D70	D71	D72
S19	D73	D74	D75	D76
S20	D77	D78	D79	D80
S21	D81	D82	D83	D84
S22	D85	D86	D87	D88
S23	D89	D90	D91	D92
S24	D93	D94	D95	D96
S25	D97	D98	D99	D100
S26	D101	D102	D103	D104
S27	D105	D106	D107	D108
S28	D109	D110	D111	D112
S29	D113	D114	D115	D116
S30	D117	D118	D119	D120
S31	D121	D122	D123	D124
S32	D125	D126	D127	D128
S33	D129	D130	D131	D132
S34	D133	D134	D135	D136

Note: This applies to the case where the S1/P1 to S8/P8 output pins are set to be segment output ports.  
 The LC75834JE do not have the S9, S18, S27, S34 output pins.

For example, the table below lists the segment output states for the S11 output pin.

Display data				Segment output pin (S11) state
D41	D42	D43	D44	
0	0	0	0	The LCD segments corresponding to COM1 to COM4 are off.
0	0	0	1	The LCD segment corresponding to COM4 is on.
0	0	1	0	The LCD segment corresponding to COM3 is on.
0	0	1	1	The LCD segments corresponding to COM3 and COM4 are on.
0	1	0	0	The LCD segment corresponding to COM2 is on.
0	1	0	1	The LCD segments corresponding to COM2 and COM4 are on.
0	1	1	0	The LCD segments corresponding to COM2 and COM3 are on.
0	1	1	1	The LCD segments corresponding to COM2, COM3 and COM4 are on.
1	0	0	0	The LCD segment corresponding to COM1 is on.
1	0	0	1	The LCD segments corresponding to COM1 and COM4 are on.
1	0	1	0	The LCD segments corresponding to COM1 and COM3 are on.
1	0	1	1	The LCD segments corresponding to COM1, COM3 and COM4 are on.
1	1	0	0	The LCD segments corresponding to COM1 and COM2 are on.
1	1	0	1	The LCD segments corresponding to COM1, COM2 and COM4 are on.
1	1	1	0	The LCD segments corresponding to COM1 to COM3 are on.
1	1	1	1	The LCD segments corresponding to COM1 to COM4 are on.

1/4 Duty, 1/2 Bias Drive Technique

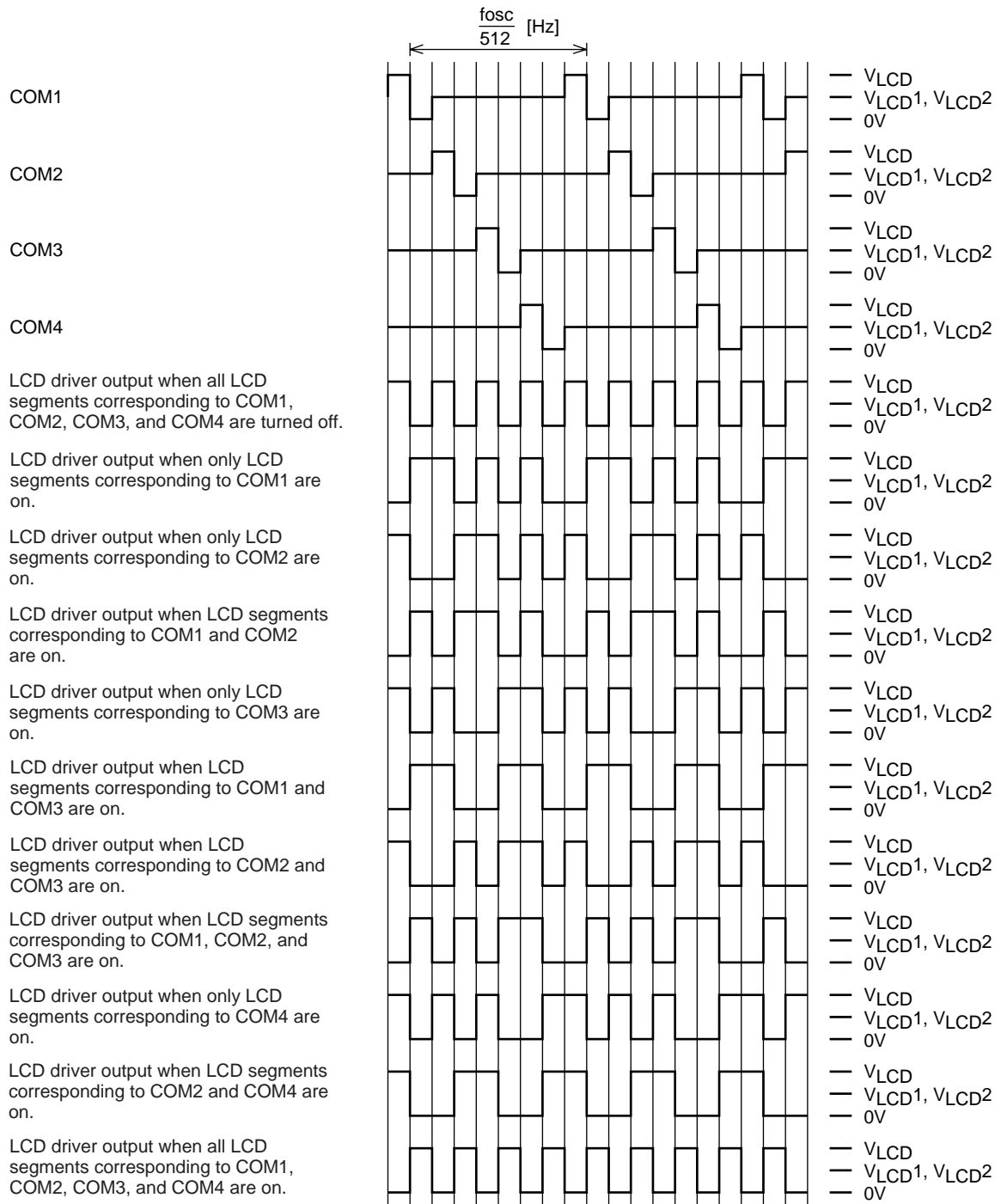

1/4 Duty, 1/2 Bias Waveforms

1/4 Duty, 1/3 Bias Drive Technique

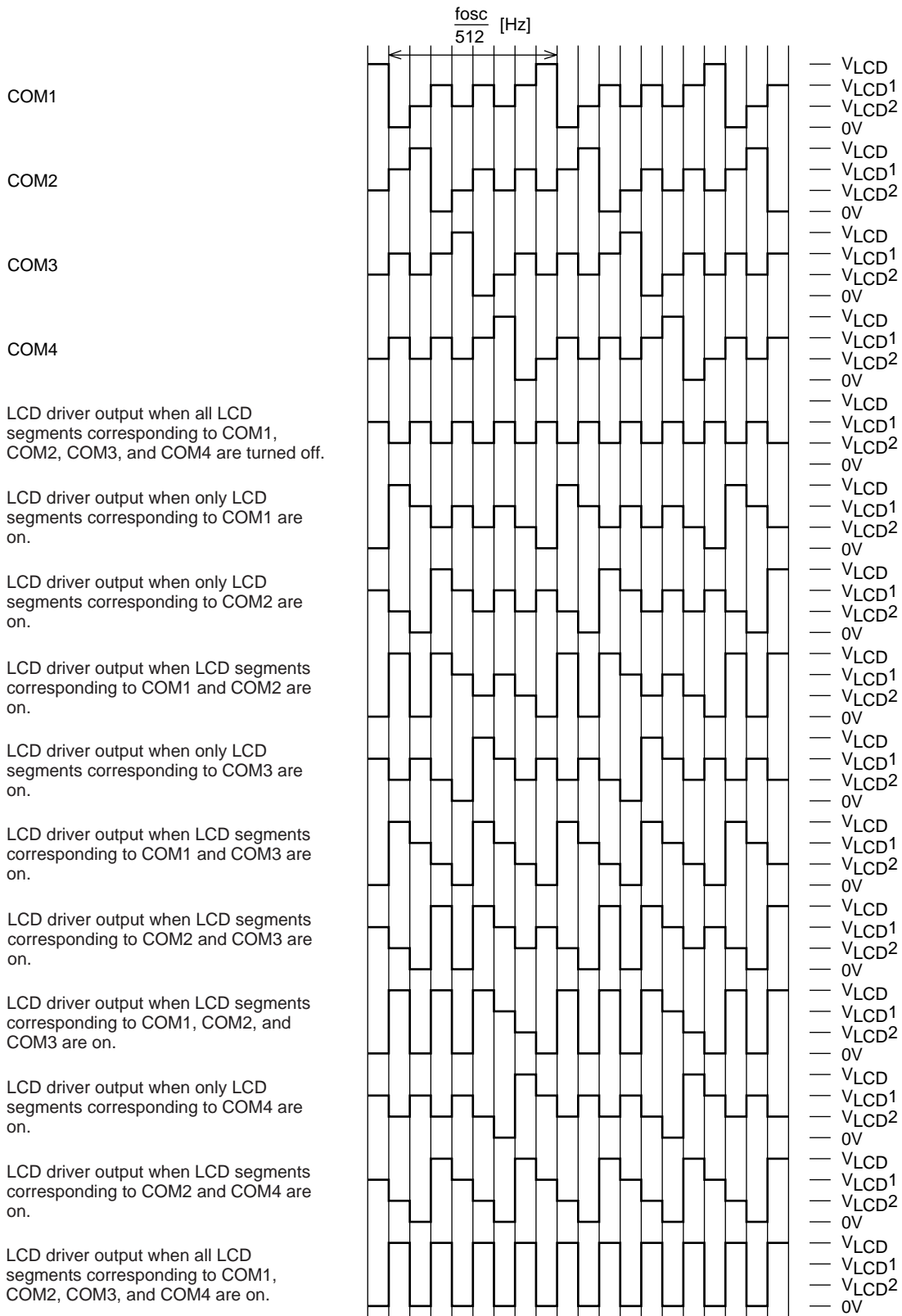

1/4 Duty, 1/3 Bias Waveforms

### The $\overline{\text{INH}}$ pin and Display Control

Since the IC internal data (the display data and the control data) is undefined when power is first applied, applications should set the  $\overline{\text{INH}}$  pin low at the same time as power is applied to turn off the display (LC75834E, LC75834W: This sets the S1/P1 to S8/P8, S9 to S34, and COM1 to COM4 to the  $V_{SS}$  level. LC75834JE: This sets the S1/P1 to S8/P8, S10 to S17, S19 to S26, S28 to S33, and COM1 to COM4 to the  $V_{SS}$  level.) and during this period send serial data from the controller. The controller should then set the  $\overline{\text{INH}}$  pin high after the data transfer has completed. This procedure prevents meaningless displays at power on. (See Figure 3.)

### Notes on the Power On/Off Sequences

Applications should observe the following sequence when turning the LC75834E, LC75834W, and LC75834JE power on and off.

- At power on: Logic block power supply ( $V_{DD}$ ) on  $\rightarrow$  LCD driver block power supply ( $V_{LCD}$ ) on
- At power off: LCD driver block power supply ( $V_{LCD}$ ) off  $\rightarrow$  Logic block power supply ( $V_{DD}$ ) off

However, if the logic and LCD driver block use a shared power supply, then the power supplies can be turned on and off at the same time.

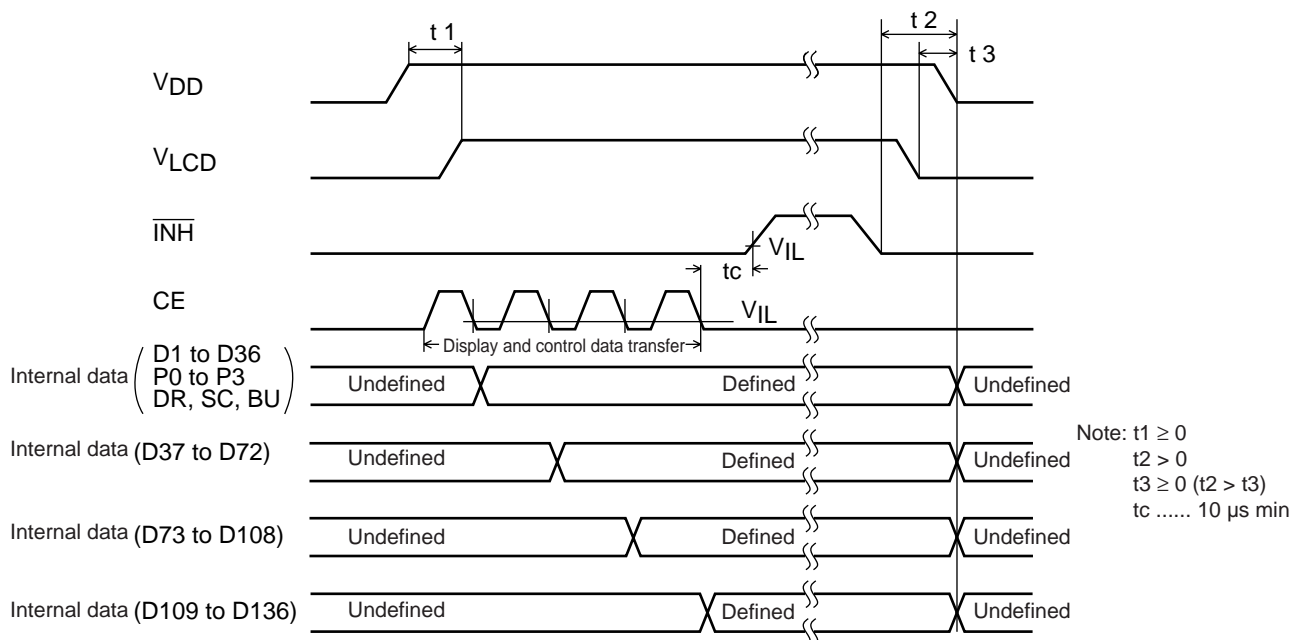

Note:  $t_1 \geq 0$   
 $t_2 > 0$   
 $t_3 \geq 0$  ( $t_2 > t_3$ )  
 $t_c \dots\dots 10 \mu\text{s min}$

Note: At the LC75834JE, the display data D33 to D36, D69 to D72, D105 to D108, D133 to D136 must be set to 0.

Figure 3

### Notes on Controller Transfer of Display Data

Since the LC75834E, LC75834W, and LC75834JE accept display data divided into four separate transfer operations, we recommend that applications transfer all of the display data within a period of less than 30 ms to prevent observable degradation of display quality.

**Sample Application Circuit 1**

1/2 Bias (for use with normal panels)

- LC75834E, LC75834W

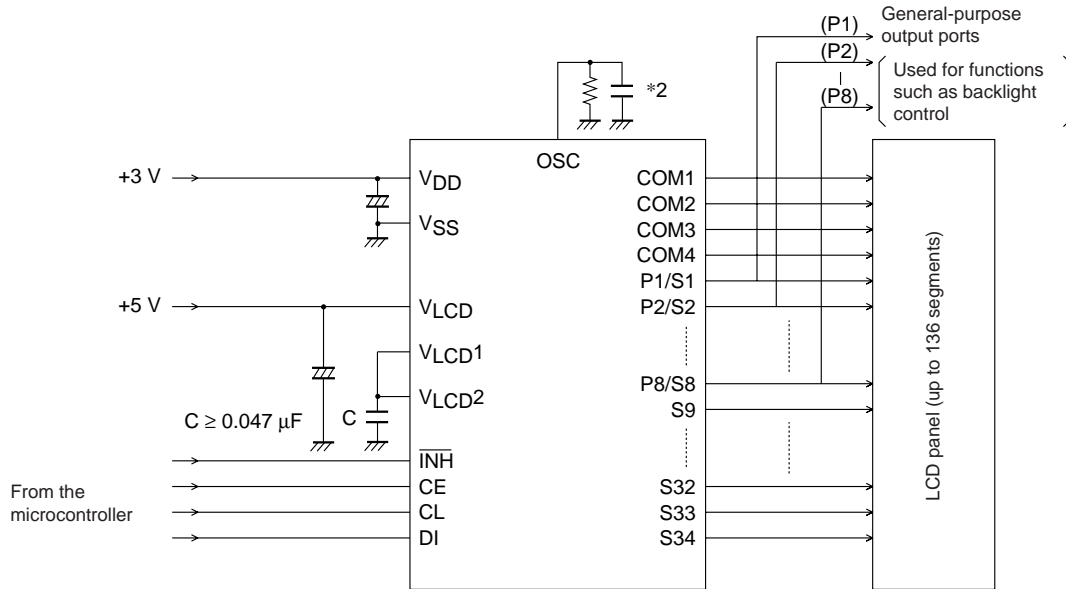

Note: \*2 When a capacitor except the recommended external capacitance ( $C_{\text{OSC}} = 680 \text{ pF}$ ) is connected the OSC pin, we recommend that applications connect the OSC pin with a capacitor in the range 220 to 2200 pF.

- LC75834JE

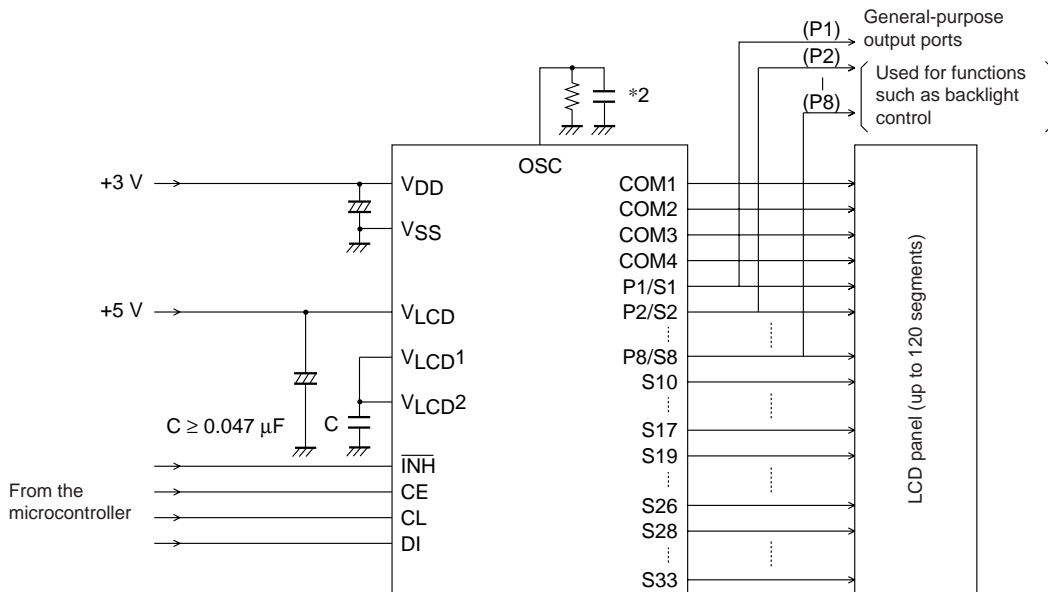

Note: \*2 When a capacitor except the recommended external capacitance ( $C_{\text{OSC}} = 680 \text{ pF}$ ) is connected the OSC pin, we recommend that applications connect the OSC pin with a capacitor in the range 220 to 2200 pF.

### Sample Application Circuit 2

1/2 Bias (for use with large panels)

- LC75834E, LC75834W

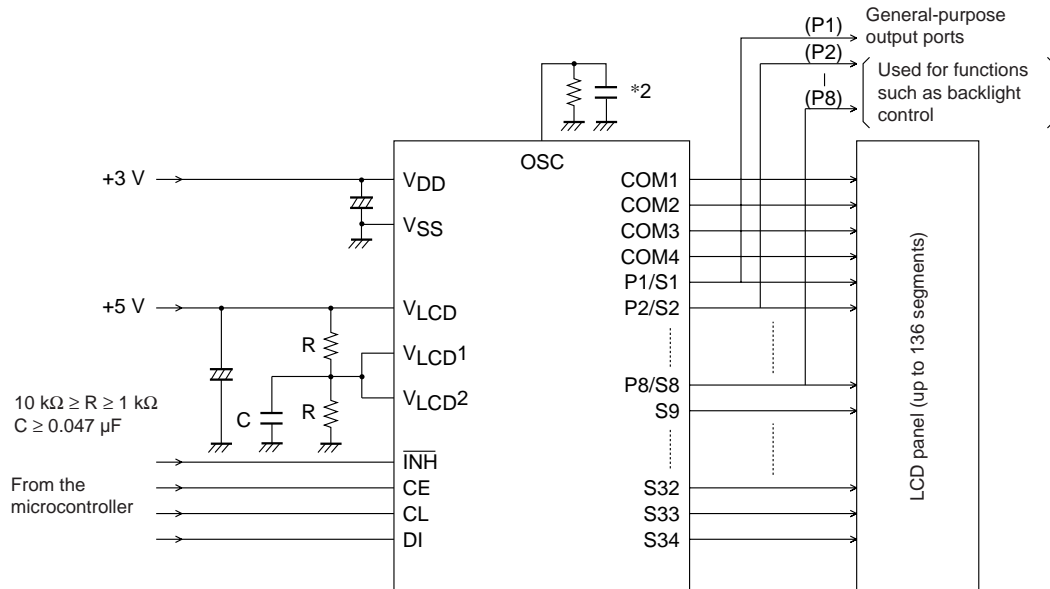

Note: \*2 When a capacitor except the recommended external capacitance ( $C_{OSC} = 680\text{ pF}$ ) is connected the OSC pin, we recommend that applications connect the OSC pin with a capacitor in the range 220 to 2200 pF.

- LC75834JE

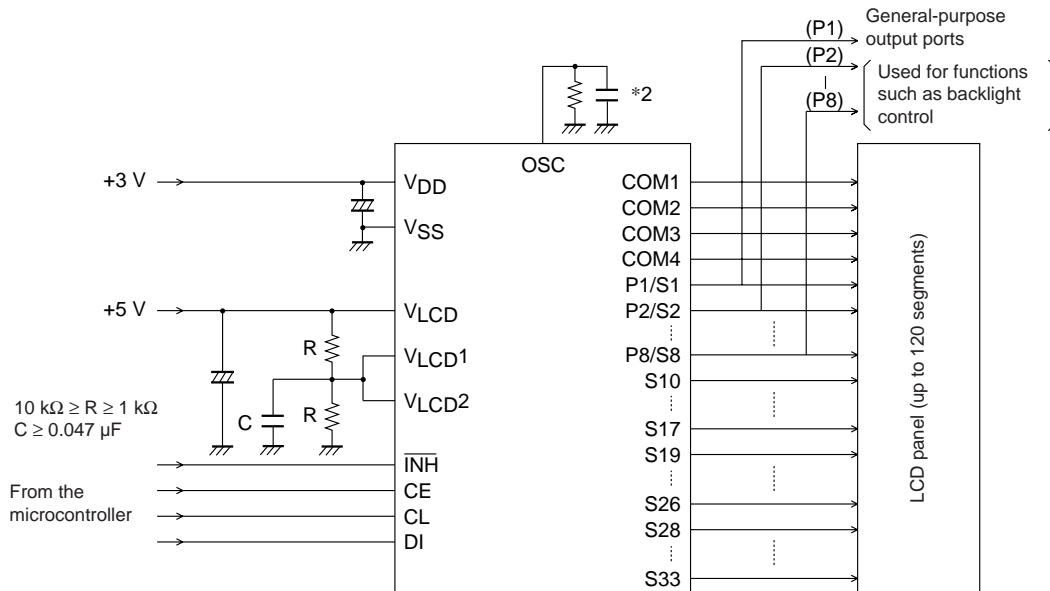

Note: \*2 When a capacitor except the recommended external capacitance ( $C_{OSC} = 680\text{ pF}$ ) is connected the OSC pin, we recommend that applications connect the OSC pin with a capacitor in the range 220 to 2200 pF.



### Sample Application Circuit 3

1/3 Bias (for use with normal panels)

- LC75834E, LC75834W

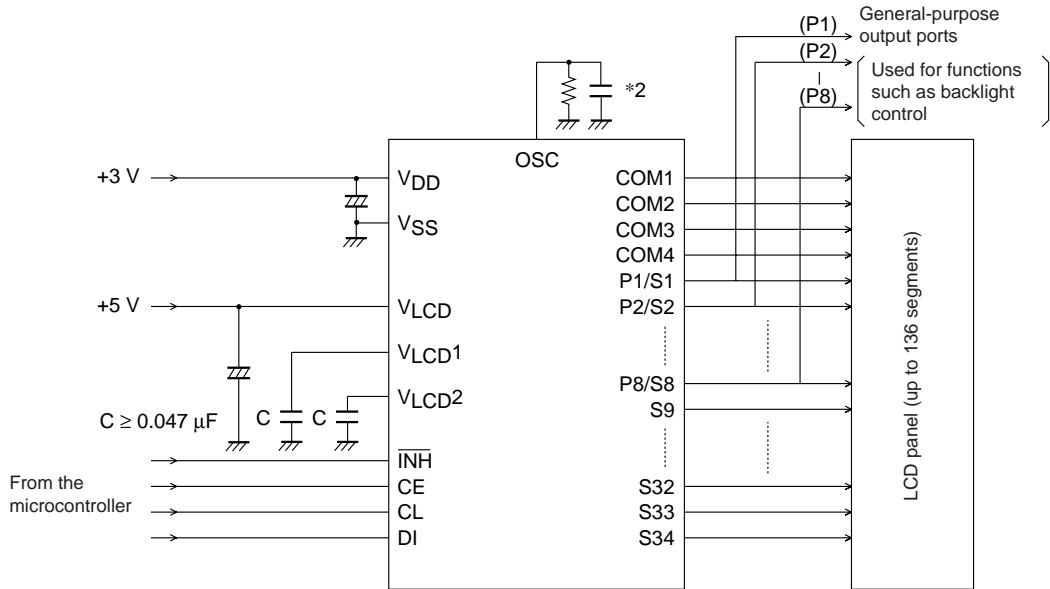

Note: \*2 When a capacitor except the recommended external capacitance ( $C_{\text{OSC}} = 680 \text{ pF}$ ) is connected the OSC pin, we recommend that applications connect the OSC pin with a capacitor in the range 220 to 2200 pF.

- LC75834JE

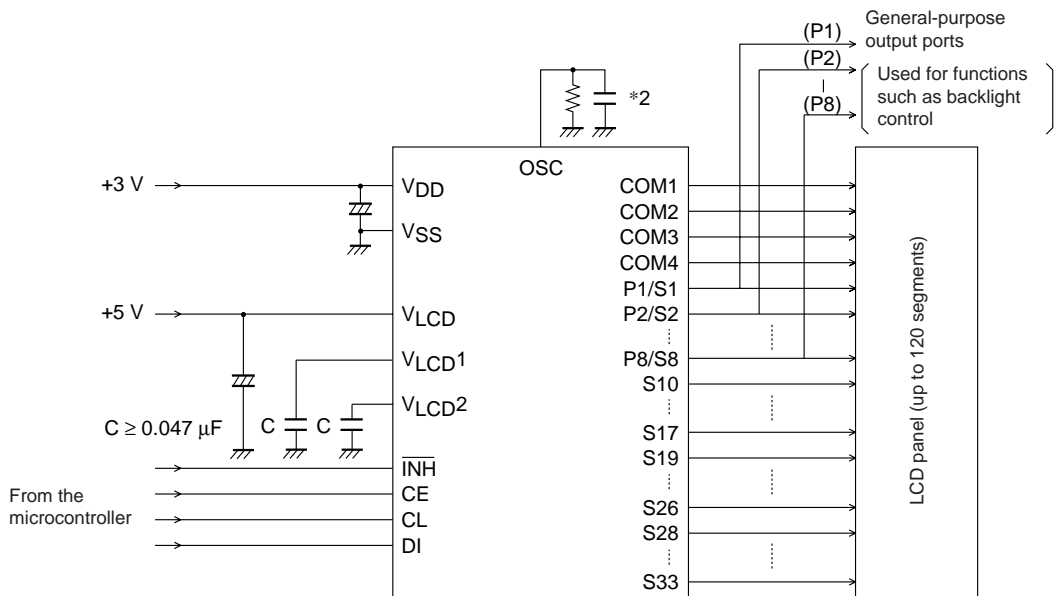

Note: \*2 When a capacitor except the recommended external capacitance ( $C_{\text{OSC}} = 680 \text{ pF}$ ) is connected the OSC pin, we recommend that applications connect the OSC pin with a capacitor in the range 220 to 2200 pF.

Sample Application Circuit 4

1/3 Bias (for use with large panels)

- LC75834E, LC75834W

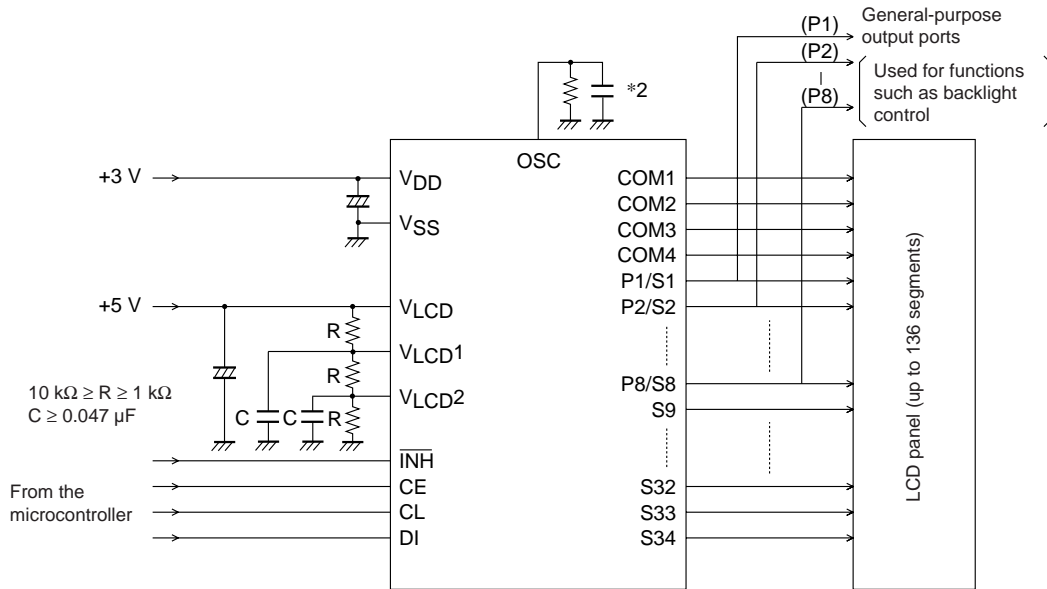

Note: \*2 When a capacitor except the recommended external capacitance ( $C_{OSC} = 680 \text{ pF}$ ) is connected the OSC pin, we recommend that applications connect the OSC pin with a capacitor in the range 220 to 2200 pF.

- LC75834JE

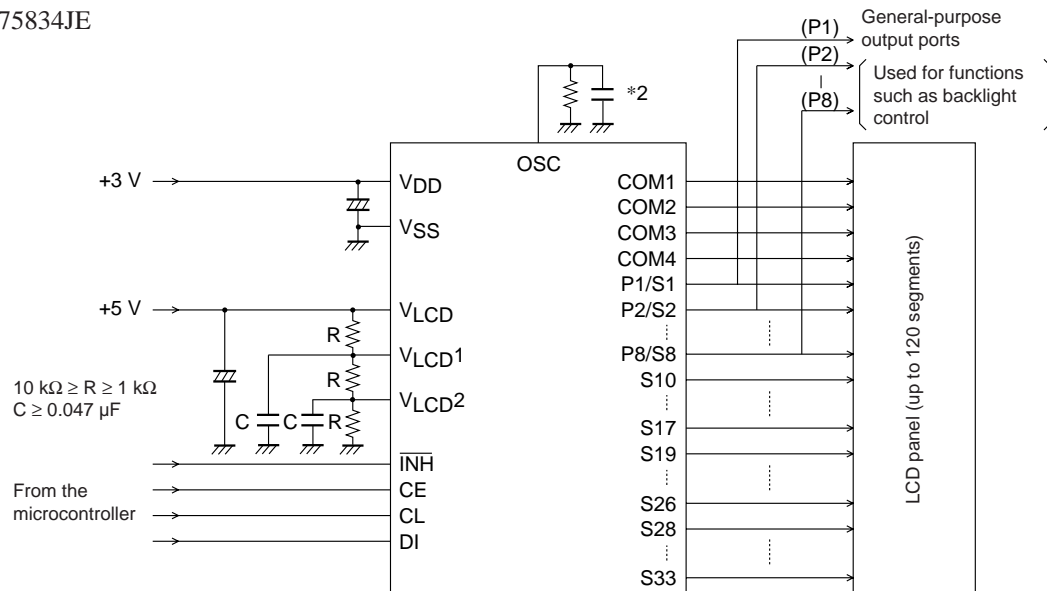

Note: \*2 When a capacitor except the recommended external capacitance ( $C_{OSC} = 680 \text{ pF}$ ) is connected the OSC pin, we recommend that applications connect the OSC pin with a capacitor in the range 220 to 2200 pF.

# LC75834E, LC75834W, LC75834JE

## Package Dimensions

unit : mm

[LC75834E]

PQFP48 14x14 / QIP48E

CASE 122BL

ISSUE A

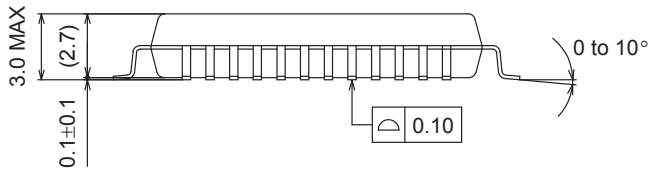
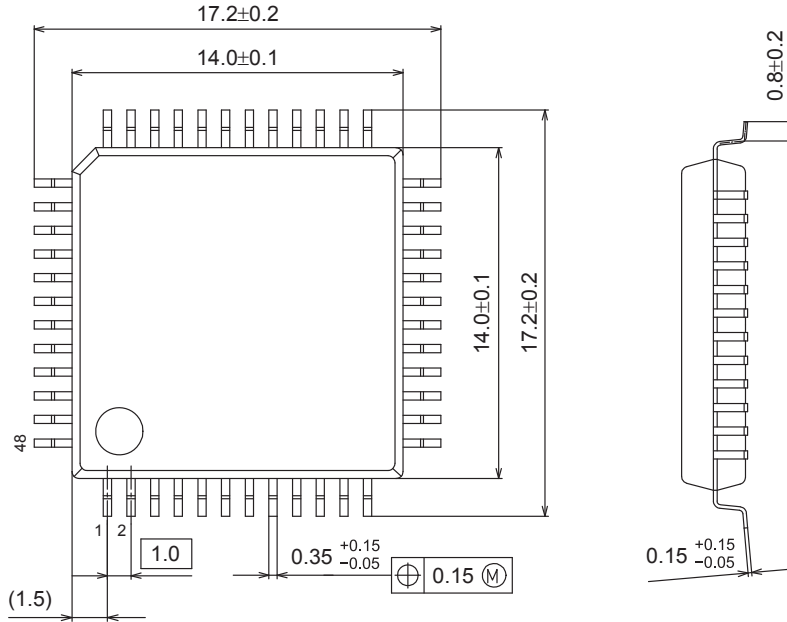

### SOLDERING FOOTPRINT\*

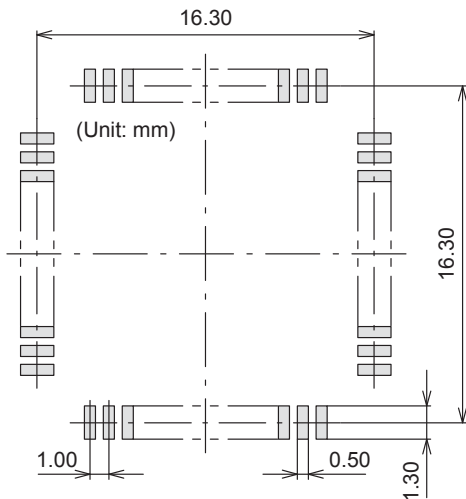

### GENERIC MARKING DIAGRAM\*

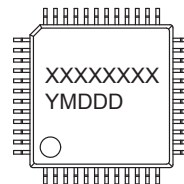

XXXXX = Specific Device Code  
 Y = Year  
 M = Month  
 DDD = Additional Traceability Data

\*This information is generic. Please refer to device data sheet for actual part marking. Pb-Free indicator, "G" or microdot "▪", may or may not be present.

NOTE: The measurements are not to guarantee but for reference only.

\*For additional information on our Pb-Free strategy and soldering details, please download the ON Semiconductor Soldering and Mounting Techniques Reference Manual, SOLDERRM/D.

# LC75834E, LC75834W, LC75834JE

## Package Dimensions

unit : mm

[LC75834W]

SPQFP48 7x7 / SQFP48

CASE 131AJ

ISSUE A

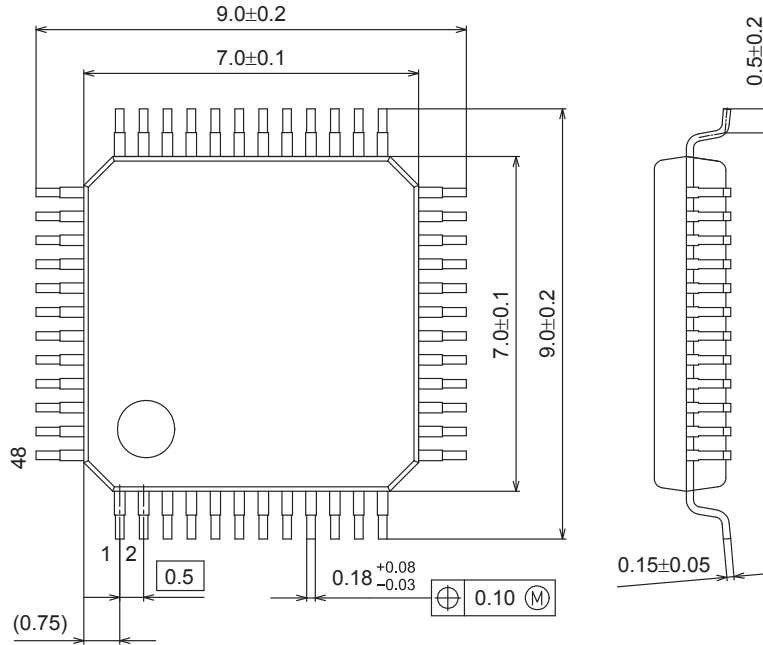

### SOLDERING FOOTPRINT\*

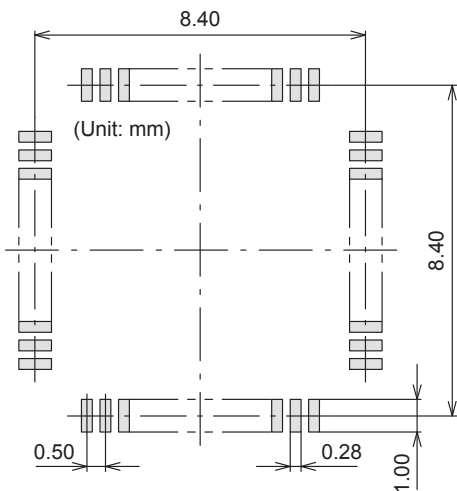

### GENERIC MARKING DIAGRAM\*

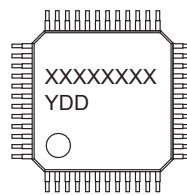

XXXXX = Specific Device Code  
Y = Year  
DD = Additional Traceability Data

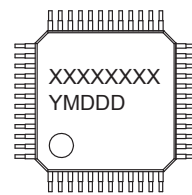

XXXXX = Specific Device Code  
Y = Year  
M = Month  
DDD = Additional Traceability Data

\*This information is generic. Please refer to device data sheet for actual part marking. Pb-Free indicator, "G" or microdot "▪", may or may not be present.

NOTE: The measurements are not to guarantee but for reference only.

\*For additional information on our Pb-Free strategy and soldering details, please download the ON Semiconductor Soldering and Mounting Techniques Reference Manual, SOLDERRM/D.

# LC75834E, LC75834W, LC75834JE

## Package Dimensions

unit : mm

[LC75834JE]

PQFP44 10x10 / QIP44M

CASE 122BK

ISSUE A

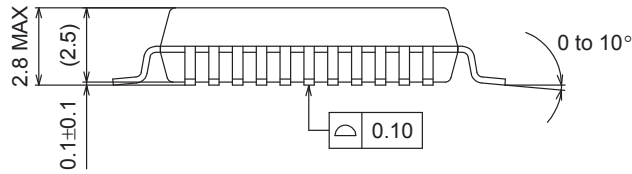
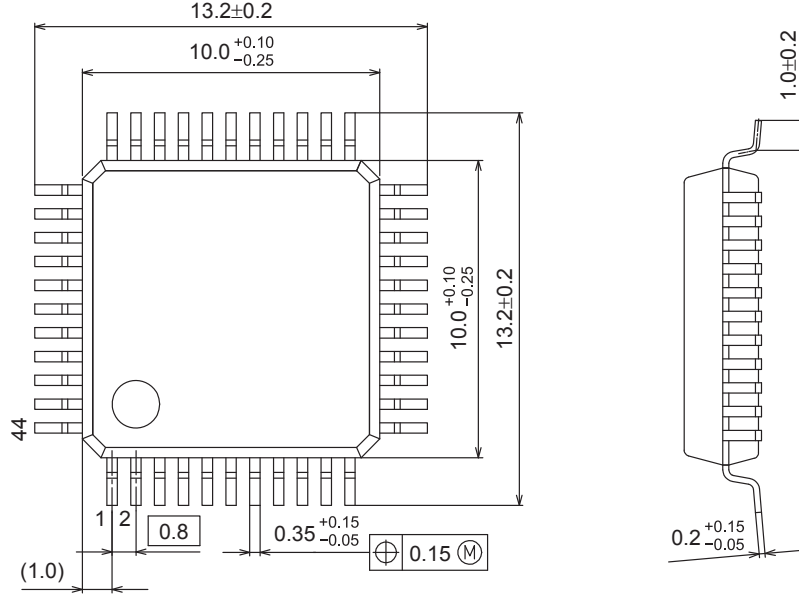

### SOLDERING FOOTPRINT\*

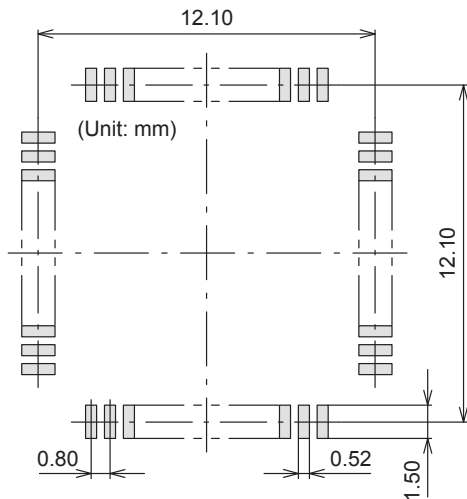

### GENERIC MARKING DIAGRAM\*

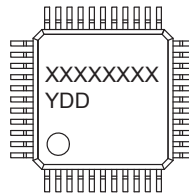

XXXXXX = Specific Device Code  
 Y = Year  
 DD = Additional Traceability Data

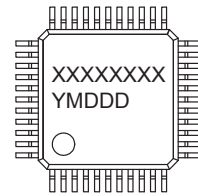

XXXXXX = Specific Device Code  
 Y = Year  
 M = Month  
 DDD = Additional Traceability Data

\*This information is generic. Please refer to device data sheet for actual part marking. Pb-Free indicator, "G" or microdot "▪", may or may not be present.

NOTE: The measurements are not to guarantee but for reference only.

\*For additional information on our Pb-Free strategy and soldering details, please download the ON Semiconductor Soldering and Mounting Techniques Reference Manual, SOLDERRM/D.

## LC75834E, LC75834W, LC75834JE

### ORDERING INFORMATION

Device	Package	Shipping (Qty / Packing)
LC75834E-E	PQFP48 14x14 / QIP48E (Pb-Free)	300 / Tray Foam
LC75834W-E	SPQFP48 7x7 / SQFP48 (Pb-Free)	1250 / Tray JEDEC
LC75834JE-E	PQFP44 10x10 / QIP44M (Pb-Free)	-

ON Semiconductor and the ON Semiconductor logo are trademarks of Semiconductor Components Industries, LLC dba ON Semiconductor or its subsidiaries in the United States and/or other countries. ON Semiconductor owns the rights to a number of patents, trademarks, copyrights, trade secrets, and other intellectual property. A listing of ON Semiconductor's product/patent coverage may be accessed at [www.onsemi.com/site/pdf/Patent-Marking.pdf](http://www.onsemi.com/site/pdf/Patent-Marking.pdf). ON Semiconductor reserves the right to make changes without further notice to any products herein. ON Semiconductor makes no warranty, representation or guarantee regarding the suitability of its products for any particular purpose, nor does ON Semiconductor assume any liability arising out of the application or use of any product or circuit, and specifically disclaims any and all liability, including without limitation special, consequential or incidental damages. Buyer is responsible for its products and applications using ON Semiconductor products, including compliance with all laws, regulations and safety requirements or standards, regardless of any support or applications information provided by ON Semiconductor. "Typical" parameters which may be provided in ON Semiconductor data sheets and/or specifications can and do vary in different applications and actual performance may vary over time. All operating parameters, including "Typicals" must be validated for each customer application by customer's technical experts. ON Semiconductor does not convey any license under its patent rights nor the rights of others. ON Semiconductor products are not designed, intended, or authorized for use as a critical component in life support systems or any FDA Class 3 medical devices or medical devices with a same or similar classification in a foreign jurisdiction or any devices intended for implantation in the human body. Should Buyer purchase or use ON Semiconductor products for any such unintended or unauthorized application, Buyer shall indemnify and hold ON Semiconductor and its officers, employees, subsidiaries, affiliates, and distributors harmless against all claims, costs, damages, and expenses, and reasonable attorney fees arising out of, directly or indirectly, any claim of personal injury or death associated with such unintended or unauthorized use, even if such claim alleges that ON Semiconductor was negligent regarding the design or manufacture of the part. ON Semiconductor is an Equal Opportunity/Affirmative Action Employer. This literature is subject to all applicable copyright laws and is not for resale in any manner.



Компания «ЭлектроПласт» предлагает заключение долгосрочных отношений при поставках импортных электронных компонентов на взаимовыгодных условиях!

Наши преимущества:

- Оперативные поставки широкого спектра электронных компонентов отечественного и импортного производства напрямую от производителей и с крупнейших мировых складов;
- Поставка более 17-ти миллионов наименований электронных компонентов;
- Поставка сложных, дефицитных, либо снятых с производства позиций;
- Оперативные сроки поставки под заказ (от 5 рабочих дней);
- Экспресс доставка в любую точку России;
- Техническая поддержка проекта, помощь в подборе аналогов, поставка прототипов;
- Система менеджмента качества сертифицирована по Международному стандарту ISO 9001;
- Лицензия ФСБ на осуществление работ с использованием сведений, составляющих государственную тайну;
- Поставка специализированных компонентов (Xilinx, Altera, Analog Devices, Intersil, Interpoint, Microsemi, Aeroflex, Peregrine, Syfer, Eurofarad, Texas Instrument, Miteq, Cobham, E2V, MA-COM, Hittite, Mini-Circuits, General Dynamics и др.);

Помимо этого, одним из направлений компании «ЭлектроПласт» является направление «Источники питания». Мы предлагаем Вам помощь Конструкторского отдела:

- Подбор оптимального решения, техническое обоснование при выборе компонента;
- Подбор аналогов;
- Консультации по применению компонента;
- Поставка образцов и прототипов;
- Техническая поддержка проекта;
- Защита от снятия компонента с производства.



#### Как с нами связаться

**Телефон:** 8 (812) 309 58 32 (многоканальный)

**Факс:** 8 (812) 320-02-42

**Электронная почта:** [org@eplast1.ru](mailto:org@eplast1.ru)

**Адрес:** 198099, г. Санкт-Петербург, ул. Калинина, дом 2, корпус 4, литера А.