

# High Speed Single/Dual N-Channel MOSFET Drivers

## FEATURES

- **Dual MOSFET Drivers in SO-8 Package or Single MOSFET Driver in MSOP Package**
- **1GΩ Electrical Isolation Between the Dual Drivers** Permits High/Low Side Gate Drive
- **1.5A Peak Output Current**
- **16ns Rise/Fall Times at  $V_{CC} = 12V$ ,  $C_L = 1nF$**
- **Wide  $V_{CC}$  Range: 4.5V to 13.2V**
- **CMOS Compatible Inputs with Hysteresis, Input Thresholds are Independent of  $V_{CC}$**
- **Driver Input Can Be Driven Above  $V_{CC}$**
- **Undervoltage Lockout**
- **Thermal Shutdown**

## APPLICATIONS

- Power Supplies
- High/Low Side Drivers
- Motor/Relay Control
- Line Drivers
- Charge Pumps

## DESCRIPTION

The LTC<sup>®</sup>1693 family drives power N-channel MOSFETs at high speed. The 1.5A peak output current reduces switching losses in MOSFETs with high gate capacitance.

The LTC1693-1 contains two noninverting drivers while the LTC1693-2 contains one noninverting and one inverting driver. These dual drivers are electrically isolated and independent. The LTC1693-3 is a single driver with an output polarity select pin.

All MOSFET drivers offer  $V_{CC}$  independent CMOS input thresholds with 1.2V of typical hysteresis. They can level-shift the input logic signal up or down to the rail-to-rail  $V_{CC}$  drive for the external MOSFET.

The LTC1693 contains an undervoltage lockout circuit and a thermal shutdown circuit that disable the external N-channel MOSFET gate drive when activated.

The LTC1693-1 and LTC1693-2 come in an 8-lead SO package. The LTC1693-3 comes in an 8-lead MSOP package.

 LTC and LT are registered trademarks of Linear Technology Corporation.

## TYPICAL APPLICATION

Two Transistor Forward Converter

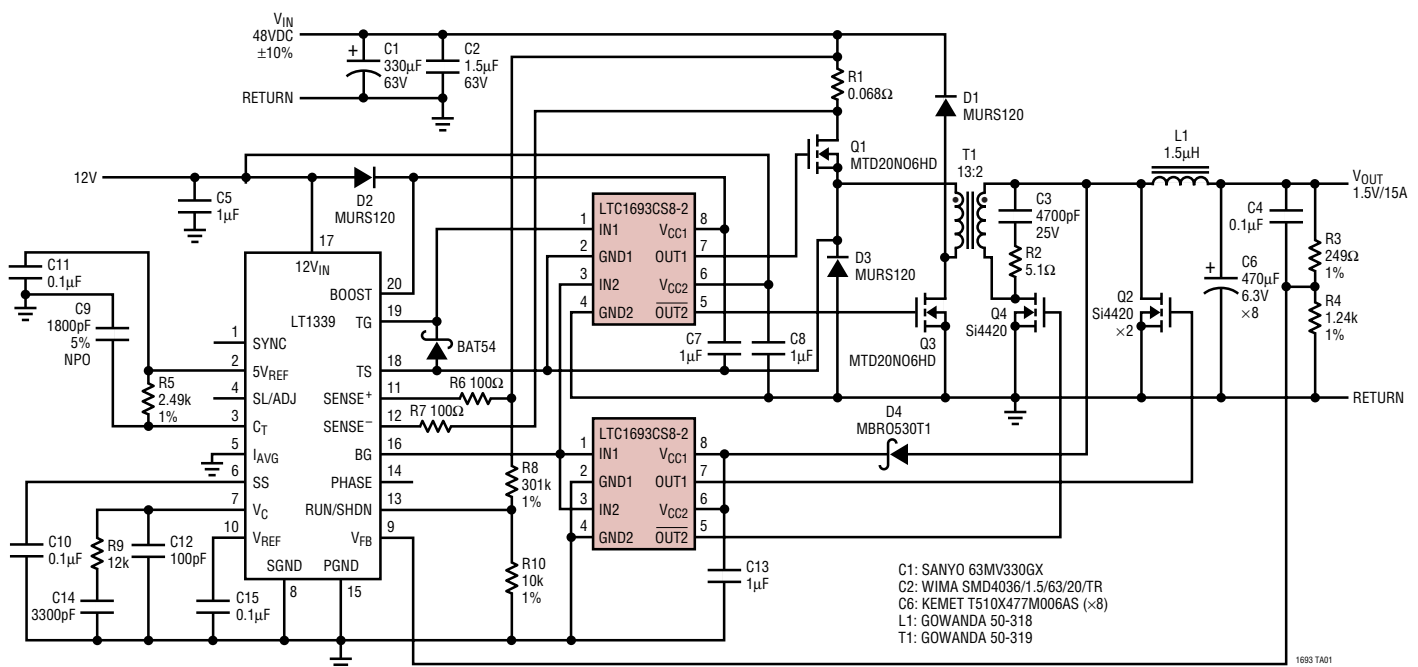

## ABSOLUTE MAXIMUM RATINGS (Note 1)

Supply Voltage ( $V_{CC}$ ) .....	14V	Operating Ambient Temperature Range	
Inputs (IN, PHASE) .....	-0.3V to 14V	C-Grade .....	0°C to 70°C
Driver Output .....	-0.3V to $V_{CC} + 0.3V$	I-Grade .....	-40°C to 85°C
GND1 to GND2 (Note 5) .....	$\pm 100V$	Storage Temperature Range .....	-65°C to 150°C
Junction Temperature .....	150°C	Lead Temperature (Soldering, 10 sec) .....	300°C

## PACKAGE/ORDER INFORMATION

ORDER PART NUMBER	S8 PART MARKING	ORDER PART NUMBER	S8 PART MARKING	ORDER PART NUMBER	MS8 PART MARKING
LTC1693-1CS8 LTC1693-1IS8	16931 16931I	LTC1693-2CS8 LTC1693-2IS8	16932 16932I	LTC1693-3CMS8	LTEB

Consult factory for Industrial and Military grade parts.

## ELECTRICAL CHARACTERISTICS The ● denotes specifications which apply over the full operating temperature range, otherwise specifications are at $T_A = 25^\circ\text{C}$ . $V_{CC} = 12V$ , unless otherwise noted.

SYMBOL	PARAMETER	CONDITIONS	MIN	TYP	MAX	UNITS
$V_{CC}$	Supply Voltage Range		4.5		13.2	V
$I_{CC}$	Quiescent Current	LTC1693-1, LTC1693-2, IN1 = IN2 = 0V (Note 2) LTC1693-3, PHASE = 12V, IN = 0V	● 400 ● 200	720 360	1100 550	$\mu\text{A}$ $\mu\text{A}$
$I_{CC(SW)}$	Switching Supply Current	LTC1693-1, LTC1693-2, $C_{OUT} = 4.7\text{nF}$ , $f_{IN} = 100\text{kHz}$ LTC1693-3, $C_{OUT} = 4.7\text{nF}$ , $f_{IN} = 100\text{kHz}$	● ●	14.4 7.2	20 10	$\text{mA}$ $\text{mA}$
<b>Input</b>						
$V_{IH}$	High Input Threshold		● 2.2	2.6	3.1	V
$V_{IL}$	Low Input Threshold		● 1.1	1.4	1.7	V
$I_{IN}$	Input Pin Bias Current		●	$\pm 0.01$	$\pm 10$	$\mu\text{A}$
$V_{PH}$	PHASE Pin High Input Threshold	(Note 3)	● 4.5	5.5	6.5	V
$I_{PH}$	PHASE Pin Pull-Up Current	PHASE = 0V (Note 3)	● 10	20	45	$\mu\text{A}$
<b>Output</b>						
$V_{OH}$	High Output Voltage	$I_{OUT} = -10\text{mA}$	● 11.92	11.97		V
$V_{OL}$	Low Output Voltage	$I_{OUT} = 10\text{mA}$	●	30	75	mV
$R_{ONL}$	Output Pull-Down Resistance			2.85		$\Omega$
$R_{ONH}$	Output Pull-Up Resistance			3.00		$\Omega$
$I_{PKL}$	Output Low Peak Current			1.70		A
$I_{PKH}$	Output High Peak Current			1.40		A

**ELECTRICAL CHARACTERISTICS** The ● denotes specifications which apply over the full operating temperature range, otherwise specifications are at  $T_A = 25^\circ\text{C}$ .  $V_{CC} = 12\text{V}$ , unless otherwise noted.

SYMBOL	PARAMETER	CONDITIONS	MIN	TYP	MAX	UNITS
<b>Switching Timing (Note 4)</b>						
$t_{RISE}$	Output Rise Time	$C_{OUT} = 1\text{nF}$	●	17.5	35	ns
		$C_{OUT} = 4.7\text{nF}$	●	48.0	85	ns
$t_{FALL}$	Output Fall Time	$C_{OUT} = 1\text{nF}$	●	16.5	35	ns
		$C_{OUT} = 4.7\text{nF}$	●	42.0	75	ns
$t_{PLH}$	Output Low-High Propagation Delay	$C_{OUT} = 1\text{nF}$	●	38.0	70	ns
		$C_{OUT} = 4.7\text{nF}$	●	40.0	75	ns
$t_{PHL}$	Output High-Low Propagation Delay	$C_{OUT} = 1\text{nF}$	●	32	70	ns
		$C_{OUT} = 4.7\text{nF}$	●	35	75	ns

**Driver Isolation**

$R_{ISO}$	GND1-GND2 Isolation Resistance	LTC1693-1, LTC1693-2 GND1-to-GND2 Voltage = 75V	●	0.075	1	$G\Omega$
-----------	--------------------------------	---	---	-------	---	-----------

**Note 1:** Absolute Maximum Ratings are those values beyond which the life of a device may be impaired.

**Note 2:** Supply current is the total current for both drivers.

**Note 3:** Only the LTC1693-3 has a PHASE pin.

**Note 4:** All AC timing specifications are guaranteed by design and are not production tested.

**Note 5:** Only applies to the LTC1693-1 and LTC1693-2.

**TYPICAL PERFORMANCE CHARACTERISTICS**

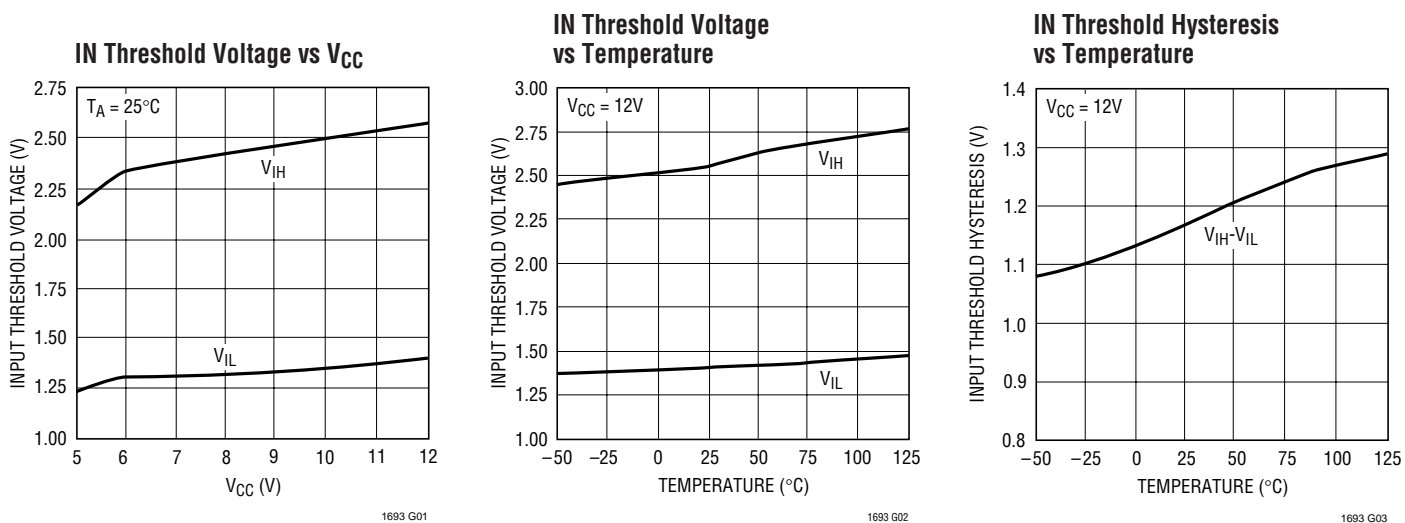

**TYPICAL PERFORMANCE CHARACTERISTICS**

**PHASE Threshold Voltage vs  $V_{CC}$**

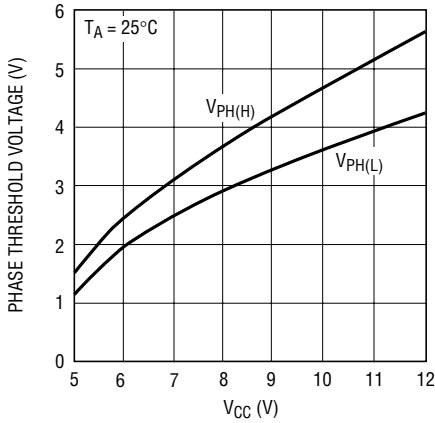

1693 G04

**Rise/Fall Time vs  $V_{CC}$**

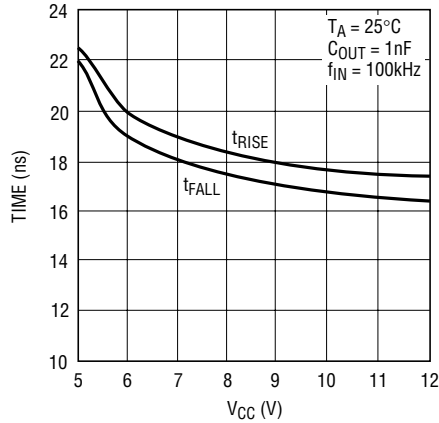

1693 G05

**Rise/Fall Time vs Temperature**

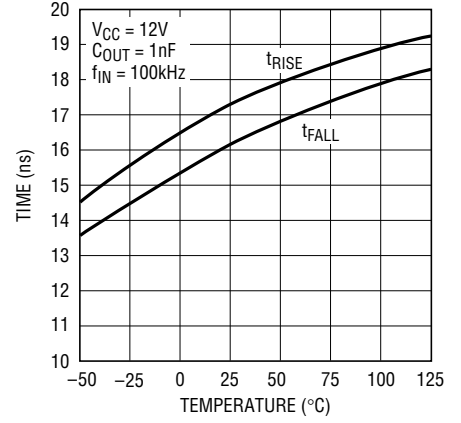

1693 G06

**Rise/Fall Time vs  $C_{OUT}$**

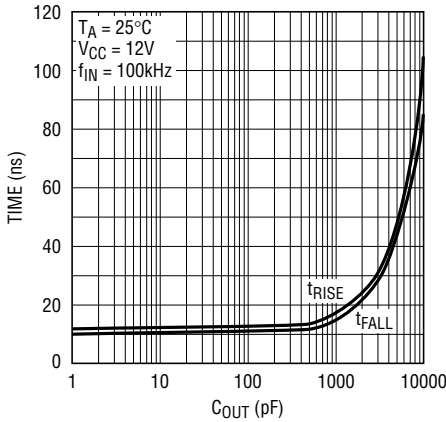

1693 G07

**Propagation Delay vs  $V_{CC}$**

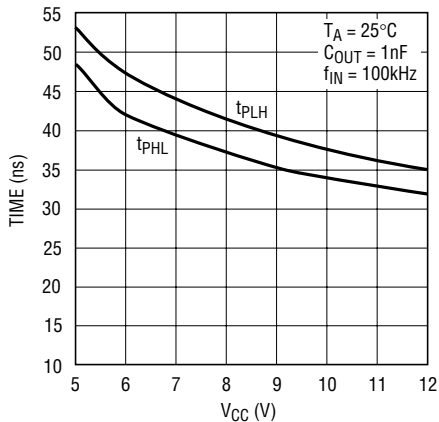

1693 G08

**Propagation Delay vs Temperature**

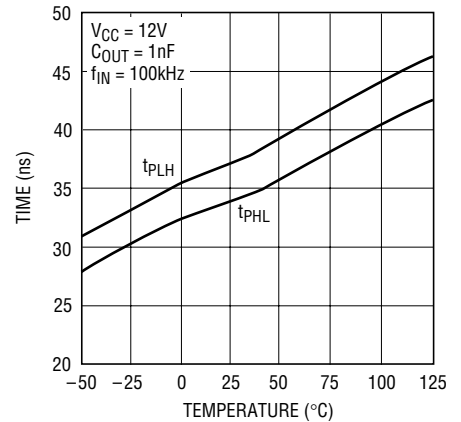

1693 G09

**Propagation Delay vs  $C_{OUT}$**

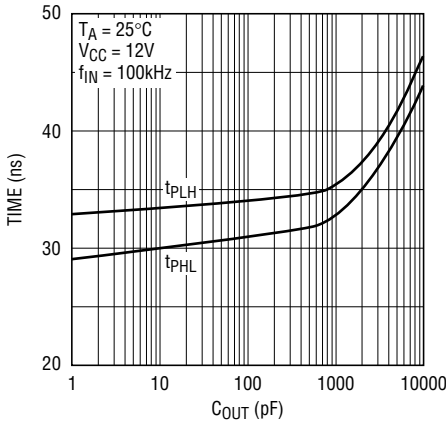

1693 G10

**Output Saturation Voltage vs Temperature**

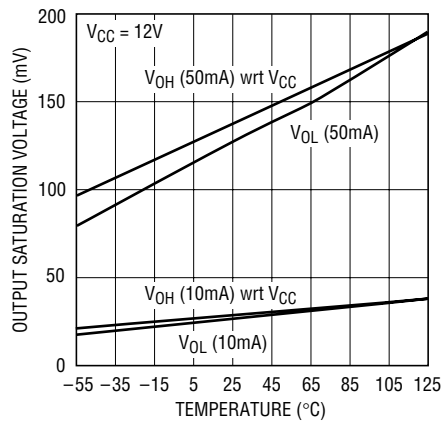

1693 G11

**Quiescent Current vs  $V_{CC}$  (Single Driver)**

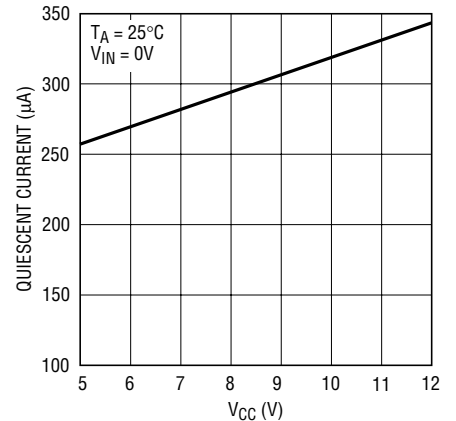

1693 G12

# TYPICAL PERFORMANCE CHARACTERISTICS

**Switching Supply Current vs C<sub>OUT</sub> (Single Driver)**

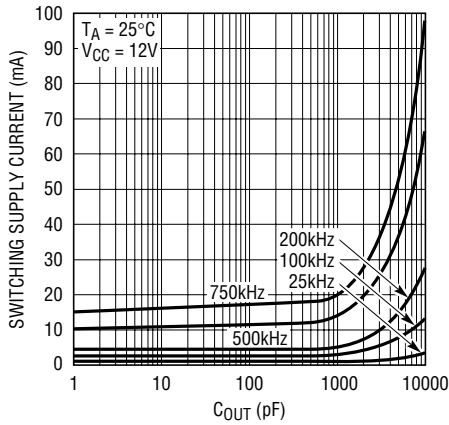

1693 G13

**V<sub>OL</sub> vs Output Current**

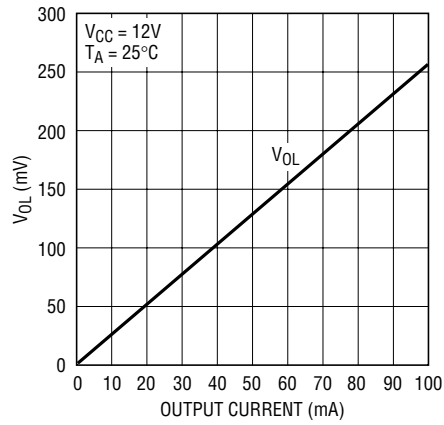

1693 G14

**V<sub>OH</sub> vs Output Current**

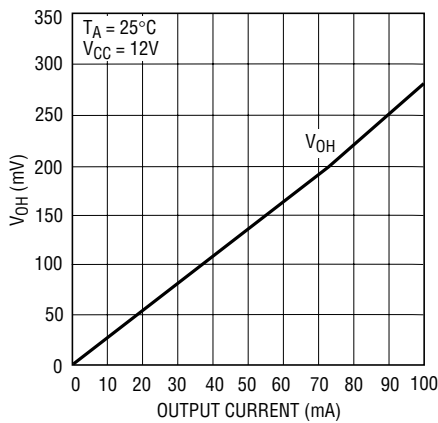

1693 G15

**Thermal Derating Curves**

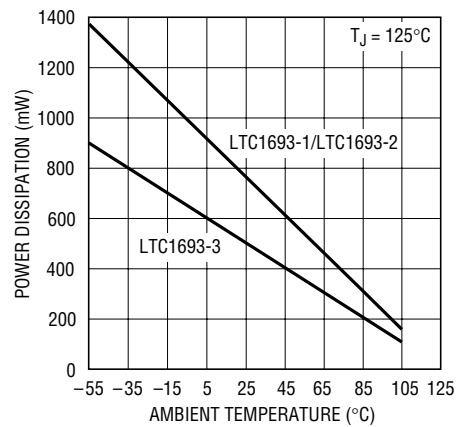

1693 G16

## PIN FUNCTIONS

### SO-8 Package (LTC1693-1, LTC1693-2)

**IN1, IN2 (Pins 1, 3):** Driver Inputs. The inputs have  $V_{CC}$  independent thresholds with 1.2V typical hysteresis to improve noise immunity.

**GND1, GND2 (Pins 2, 4):** Driver Grounds. Connect to a low impedance ground. The  $V_{CC}$  bypass capacitor should connect directly to this pin. The source of the external MOSFET should also connect directly to the ground pin. This minimizes the AC current path and improves signal integrity. The ground pins should not be tied together if isolation is required between the two drivers of the LTC1693-1 and the LTC1693-2.

**OUT 1, OUT2 (Pins 5, 7):** Driver Outputs. The LTC1693-1's outputs are in phase with their respective inputs (IN1, IN2). The LTC1693-2's topside driver output (OUT1) is in phase with its input (IN1) and the bottom side driver's output (OUT2) is opposite in phase with respect to its input pin (IN2).

**$V_{CC1}$ ,  $V_{CC2}$  (Pins 6, 8):** Power Supply Inputs.

### MSOP Package (LTC1693-3)

**IN (Pin 1):** Driver Input. The input has  $V_{CC}$  independent thresholds with hysteresis to improve noise immunity.

**NC (Pins 2, 5, 6):** No Connect.

**PHASE (Pin 3):** Output Polarity Select. Connect this pin to  $V_{CC}$  or leave it floating for noninverting operation. Ground this pin for inverting operation. The typical PHASE pin input current when pulled low is 20 $\mu$ A.

**GND (Pin 4):** Driver Ground. Connect to a low impedance ground. The  $V_{CC}$  bypass capacitor should connect directly to this pin. The source of the external MOSFET should also connect directly to the ground pin. This minimizes the AC current path and improves signal integrity.

**OUT (Pin 7):** Driver Output.

**$V_{CC}$  (Pin 8):** Power Supply Input.

## BLOCK DIAGRAMS

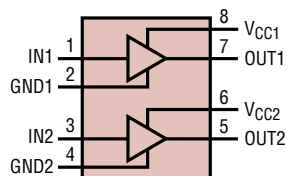

LTC1693-1  
DUAL NONINVERTING DRIVER

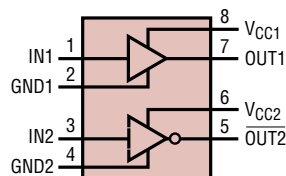

LTC1693-2  
TOPSIDE NONINVERTING DRIVER  
AND BOTTOM SIDE INVERTING DRIVER

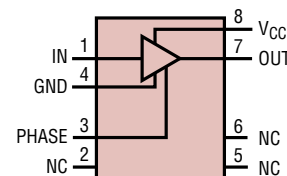

LTC1693-3  
SINGLE DRIVER WITH  
POLARITY SELECT 1693 BD

## TEST CIRCUITS

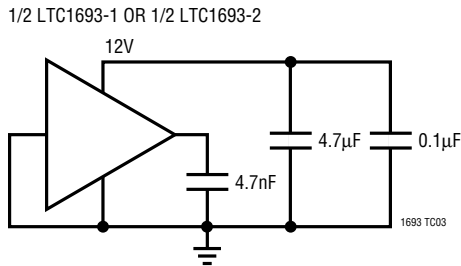
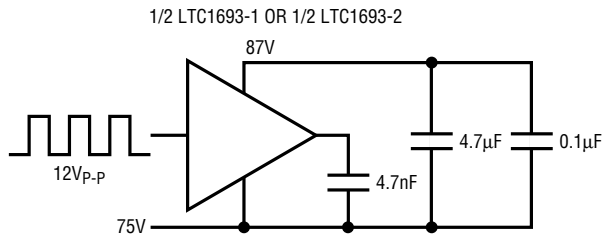

75V High Side Switching Test

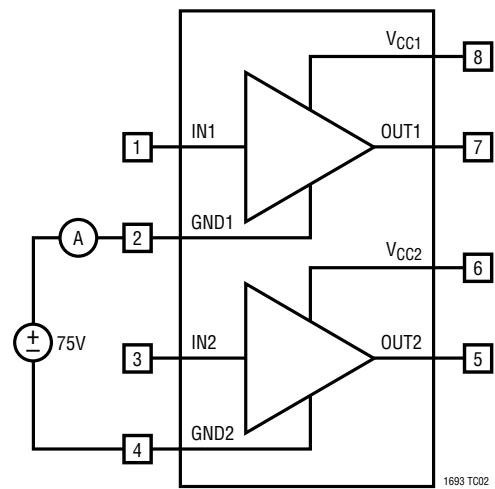

LTC1693-1, LTC1693-2 Ground Isolation Test

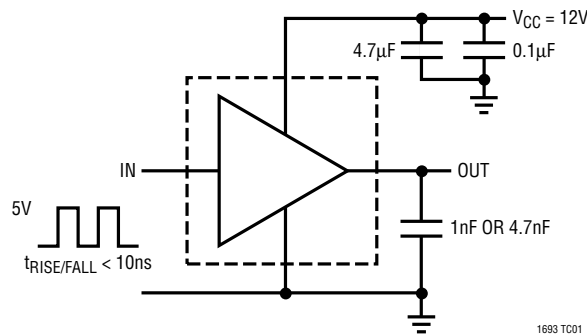

AC Parameter Measurements

## TIMING DIAGRAM

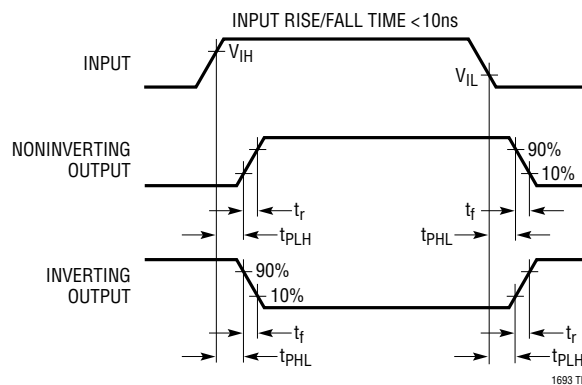

## APPLICATIONS INFORMATION

### Overview

The LTC1693 single and dual drivers allow 3V- or 5V-based digital circuits to drive power MOSFETs at high speeds. A power MOSFET's gate-charge loss increases with switching frequency and transition time. The LTC1693 is capable of driving a 1nF load with a 16ns rise and fall time using a  $V_{CC}$  of 12V. This eliminates the need for higher voltage supplies, such as 18V, to reduce the gate charge losses.

The LTC1693's 360 $\mu$ A quiescent current is an order of magnitude lower than most other drivers/buffers. This improves system efficiency in both standby and switching operation. Since a power MOSFET generally accounts for the majority of power loss in a converter, addition of the LTC1693 to a high power converter design greatly improves efficiency, using very little board space.

The LTC1693-1 and LTC1693-2 are dual drivers that are electrically isolated. Each driver has independent operation from the other. Drivers may be used in different parts of a system, such as a circuit requiring a floating driver and the second driver being powered with respect to ground.

### Input Stage

The LTC1693 employs 3V CMOS compatible input thresholds that allow a low voltage digital signal to drive *standard* power MOSFETs. The LTC1693 incorporates a 4V internal regulator to bias the input buffer. This allows the 3V CMOS compatible input thresholds ( $V_{IH} = 2.6V$ ,  $V_{IL} = 1.4V$ ) to be independent of variations in  $V_{CC}$ . The 1.2V hysteresis between  $V_{IH}$  and  $V_{IL}$  eliminates false triggering due to ground noise during switching transitions. The LTC1693's input buffer has a high input impedance and draws less than 10 $\mu$ A during standby.

### Output Stage

The LTC1693's output stage is essentially a CMOS inverter, as shown by the P- and N-channel MOSFETs in Figure 1 (P1 and N1). The CMOS inverter swings rail-to-rail, giving maximum voltage drive to the load. This large voltage swing is important in driving external power MOSFETs, whose  $R_{DS(ON)}$  is inversely proportional to its gate overdrive voltage ( $V_{GS} - V_T$ ).

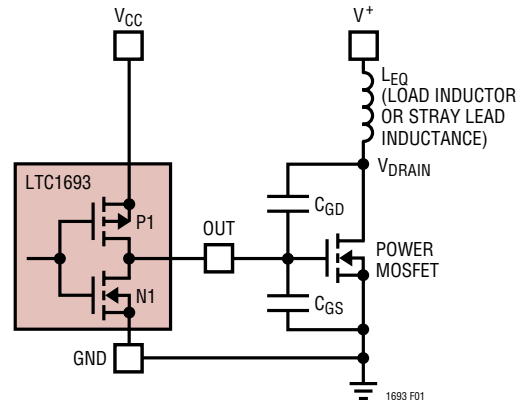

Figure 1. Capacitance Seen by OUT During Switching

The LTC1693's output peak currents are 1.4A (P1) and 1.7A (N1) respectively. The N-channel MOSFET (N1) has higher current drive capability so it can discharge the power MOSFET's gate capacitance during high-to-low signal transitions. When the power MOSFET's gate is pulled low by the LTC1693, its drain voltage is pulled high by its load (e.g., a resistor or inductor). The slew rate of the drain voltage causes current to flow back to the MOSFET's gate through its gate-to-drain capacitance. If the MOSFET driver does not have sufficient sink current capability (low output impedance), the current through the power MOSFET's Miller capacitance ( $C_{GD}$ ) can momentarily pull the gate high, turning the MOSFET back on.

### Rise/Fall Time

Since the power MOSFET generally accounts for the majority of power lost in a converter, it's important to quickly turn it either fully "on" or "off" thereby minimizing the transition time in its linear region. The LTC1693 has rise and fall times on the order of 16ns, delivering about 1.4A to 1.7A of peak current to a 1nF load with a  $V_{CC}$  of only 12V.

The LTC1693's rise and fall times are determined by the peak current capabilities of P1 and N1. The predriver, shown in Figure 1 driving P1 and N1, uses an adaptive method to minimize cross-conduction currents. This is done with a 6ns nonoverlapping transition time. N1 is fully turned off before P1 is turned-on and vice-versa using this 6ns buffer time. This minimizes any cross-conduction currents while N1 and P1 are switching on and off yet is short enough to not prolong their rise and fall times.



## APPLICATIONS INFORMATION

### Driver Electrical Isolation

The LTC1693-1 and LTC1693-2 incorporate two individual drivers in a single package that can be separately connected to GND and V<sub>CC</sub> connections. Figure 2 shows a circuit with an LTC1693-2, its top driver left floating while the bottom

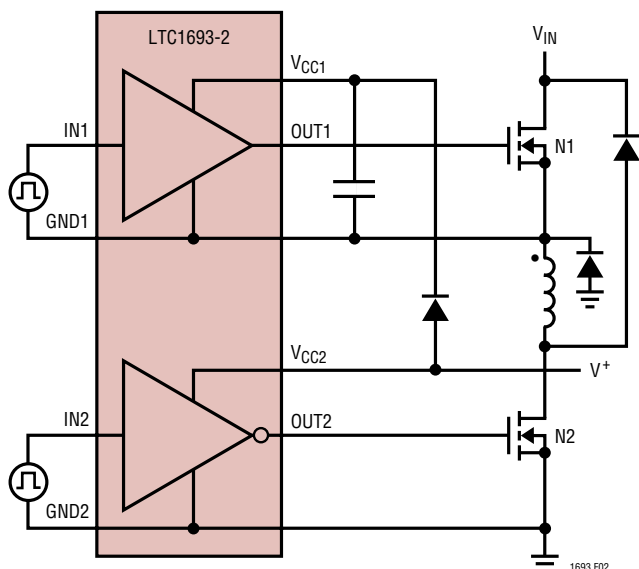

Figure 2. Simplified LTC1693-2 Floating Driver Application

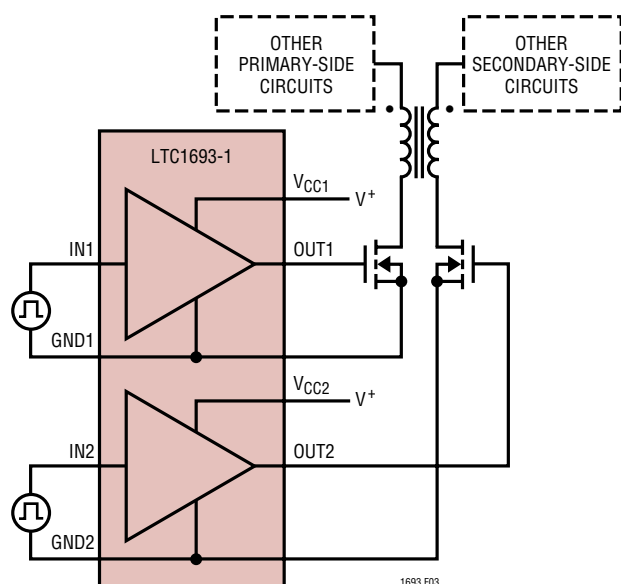

Figure 3. Simplified LTC1693-1 Application with Different Ground Potentials

driver is powered with respect to ground. Similarly Figure 3 shows a simplified circuit of a LTC1693-1 which is driving MOSFETs with different ground potentials. Because there is 1GΩ of isolation between these drivers in a single package, ground current on the secondary side will not recirculate to the primary side of the circuit.

### Power Dissipation

To ensure proper operation and long term reliability, the LTC1693 must not operate beyond its maximum temperature rating. Package junction temperature can be calculated by:

$$T_J = T_A + PD(\theta_{JA})$$

where:

T<sub>J</sub> = Junction Temperature

T<sub>A</sub> = Ambient Temperature

PD = Power Dissipation

θ<sub>JA</sub> = Junction-to-Ambient Thermal Resistance

Power dissipation consists of standby and switching power losses:

$$PD = PSTDBY + PAC$$

where:

PSTDBY = Standby Power Losses

PAC = AC Switching Losses

The LTC1693 consumes very little current during standby. This DC power loss per driver at V<sub>CC</sub> = 12V is only (360μA)(12V) = 4.32mW.

AC switching losses are made up of the output capacitive load losses and the transition state losses. The capacitive load losses are primarily due to the large AC currents needed to charge and discharge the load capacitance during switching. Load losses for the CMOS driver driving a pure capacitive load C<sub>OUT</sub> will be:

$$\text{Load Capacitive Power } (C_{OUT}) = (C_{OUT})(f)(V_{CC})^2$$

The power MOSFET's gate capacitance seen by the driver output varies with its V<sub>GS</sub> voltage level during switching. A power MOSFET's capacitive load power dissipation can be calculated by its gate charge factor, Q<sub>G</sub>. The Q<sub>G</sub> value

## APPLICATIONS INFORMATION

corresponding to MOSFET's  $V_{GS}$  value ( $V_{CC}$  in this case) can be readily obtained from the manufacturer's  $Q_{GS}$  vs  $V_{GS}$  curves:

$$\text{Load Capacitive Power (MOS)} = (V_{CC})(Q_G)(f)$$

Transition state power losses are due to both AC currents required to charge and discharge the drivers' internal nodal capacitances and cross-conduction currents in the internal gates.

### UVLO and Thermal Shutdown

The LTC1693's UVLO detector disables the input buffer and pulls the output pin to ground if  $V_{CC} < 4V$ . The output remains off from  $V_{CC} = 1V$  to  $V_{CC} = 4V$ . This ensures that during start-up or improper supply voltage values, the LTC1693 will keep the output power MOSFET off.

The LTC1693 also has a thermal detector that similarly disables the input buffer and grounds the output pin if junction temperature exceeds  $145^{\circ}C$ . The thermal shutdown circuit has  $20^{\circ}C$  of hysteresis. This thermal limit helps to shut down the system should a fault condition occur.

### Input Voltage Range

LTC1693's input pin is a high impedance node and essentially draws negligible input current. This simplifies the input drive circuitry required for the input.

The LTC1693 typically has 1.2V of hysteresis between its low and high input thresholds. This increases the driver's robustness against any ground bounce noises. However, care should still be taken to keep this pin from any noise pickup, especially in high frequency switching applications.

In applications where the input signal swings below the GND pin potential, the input pin voltage must be clamped to prevent the LTC1693's parasitic substrate diode from turning on. This can be accomplished by connecting a series current limiting resistor  $R_1$  and a shunting Schottky diode  $D_1$  to the input pin (Figure 4).  $R_1$  ranges from  $100\Omega$  to  $470\Omega$  while  $D_1$  can be a BAT54 or 1N5818/9.

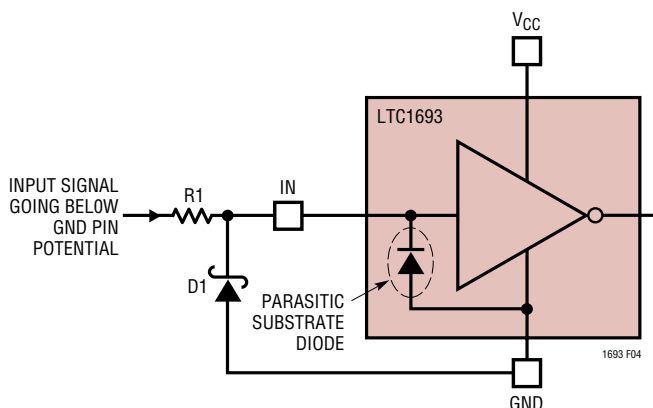

Figure 4

### Bypassing and Grounding

LTC1693 requires proper  $V_{CC}$  bypassing and grounding due to its high speed switching (ns) and large AC currents (A). Careless component placement and PCB trace routing may cause excessive ringing and under/overshoot.

To obtain the optimum performance from the LTC1693:

- Mount the bypass capacitors as close as possible to the  $V_{CC}$  and GND pins. The leads should be shortened as much as possible to reduce lead inductance. It is recommended to have a  $0.1\mu F$  ceramic in parallel with a low ESR  $4.7\mu F$  bypass capacitor.

For high voltage switching in an inductive environment, ensure that the bypass capacitors'  $V_{MAX}$  ratings are high enough to prevent breakdown. This is especially important for floating driver applications.

- Use a low inductance, low impedance ground plane to reduce any ground drop and stray capacitance. Remember that the LTC1693 switches 1.5A peak currents and any significant ground drop will degrade signal integrity.
- Plan the ground routing carefully. Know where the large load switching current is coming from and going to. Maintain separate ground return paths for the input pin and output pin. Terminate these two ground traces only at the GND pin of the driver (STAR network).
- Keep the copper trace between the driver output pin and the load short and wide.

# TYPICAL APPLICATIONS

SLIC Power Supply

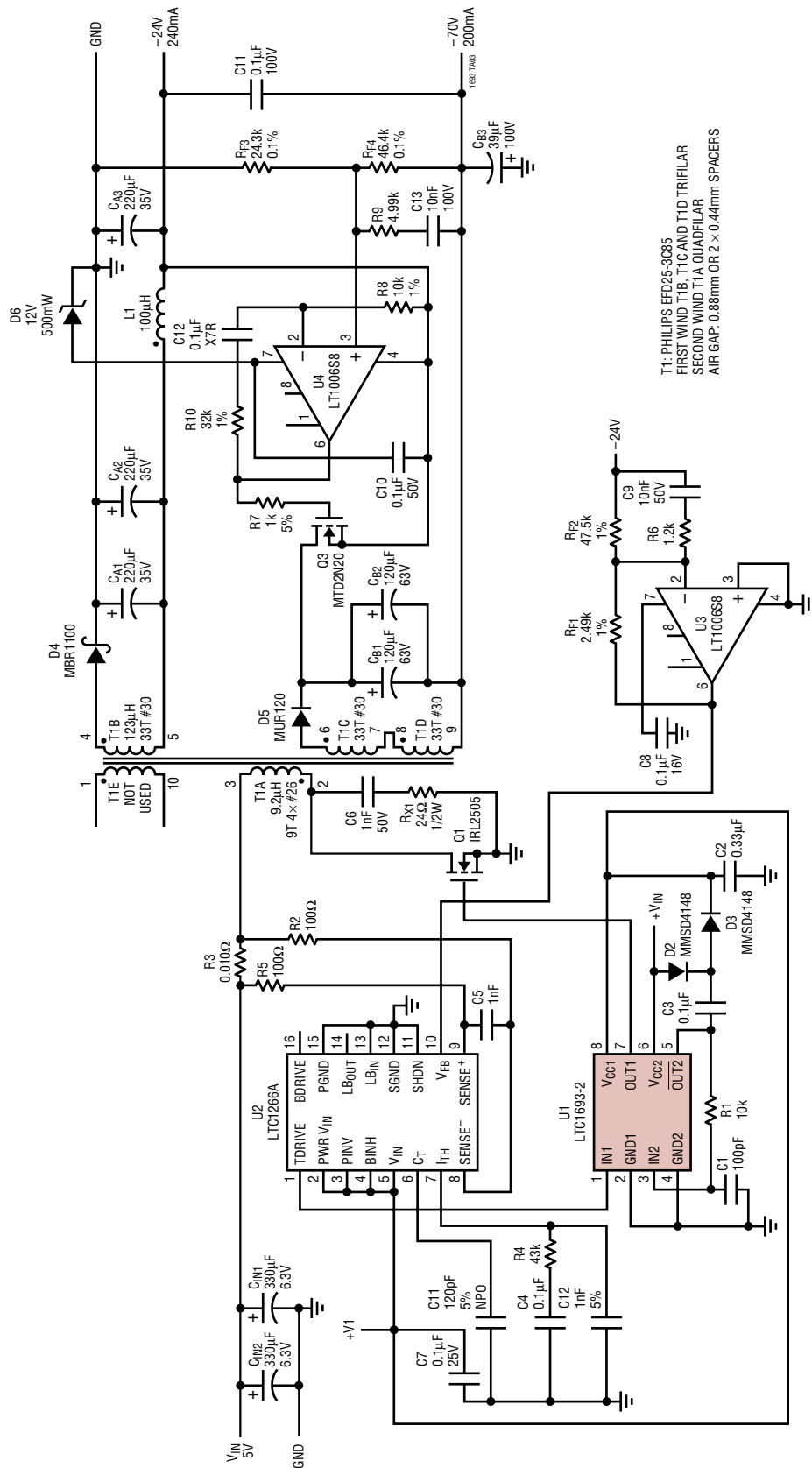

TYPICAL APPLICATIONS

Negative-to-Positive Synchronous Boost Converter

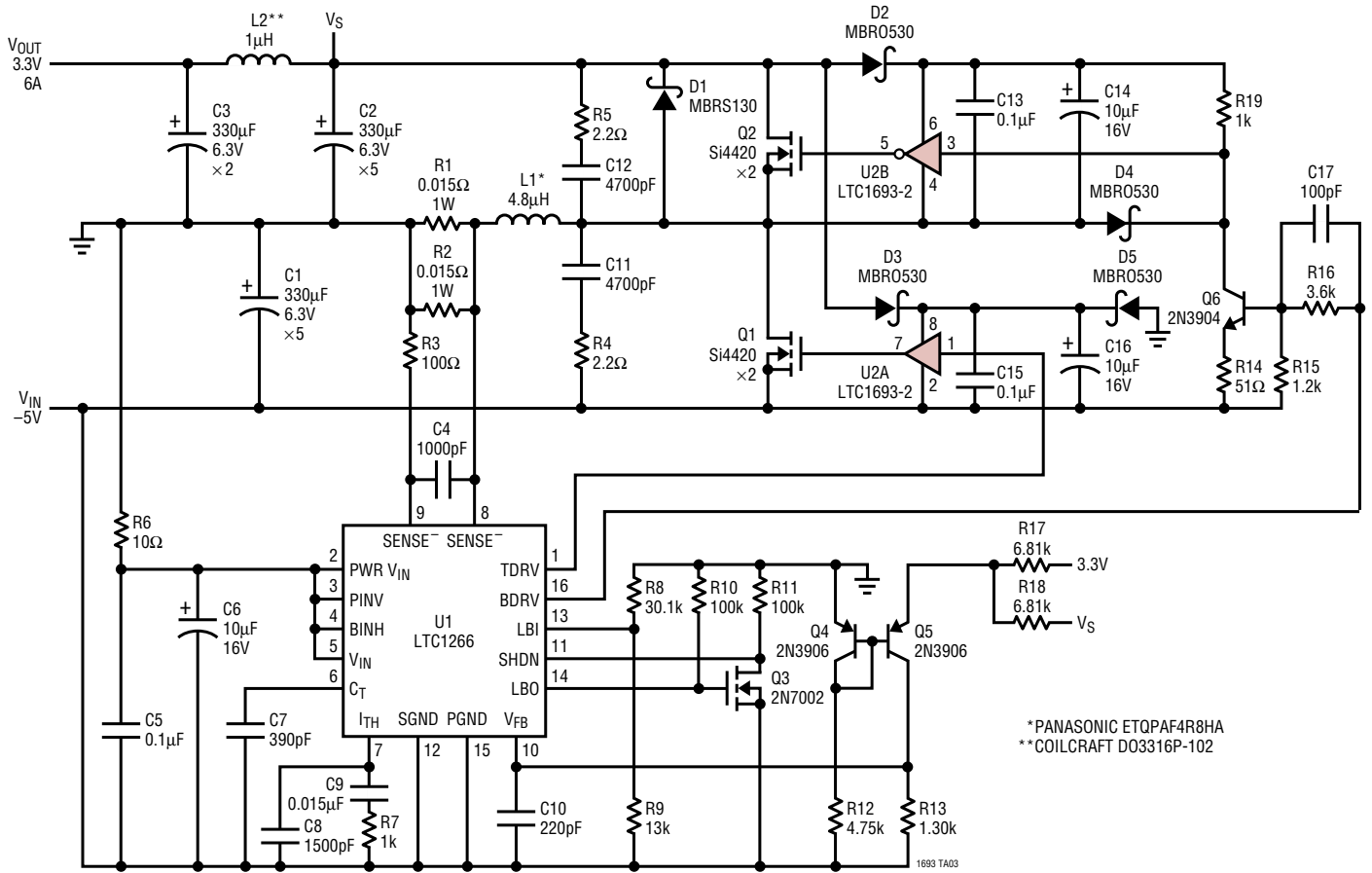

# TYPICAL APPLICATIONS

## Multiple Output Telecom Power Supply

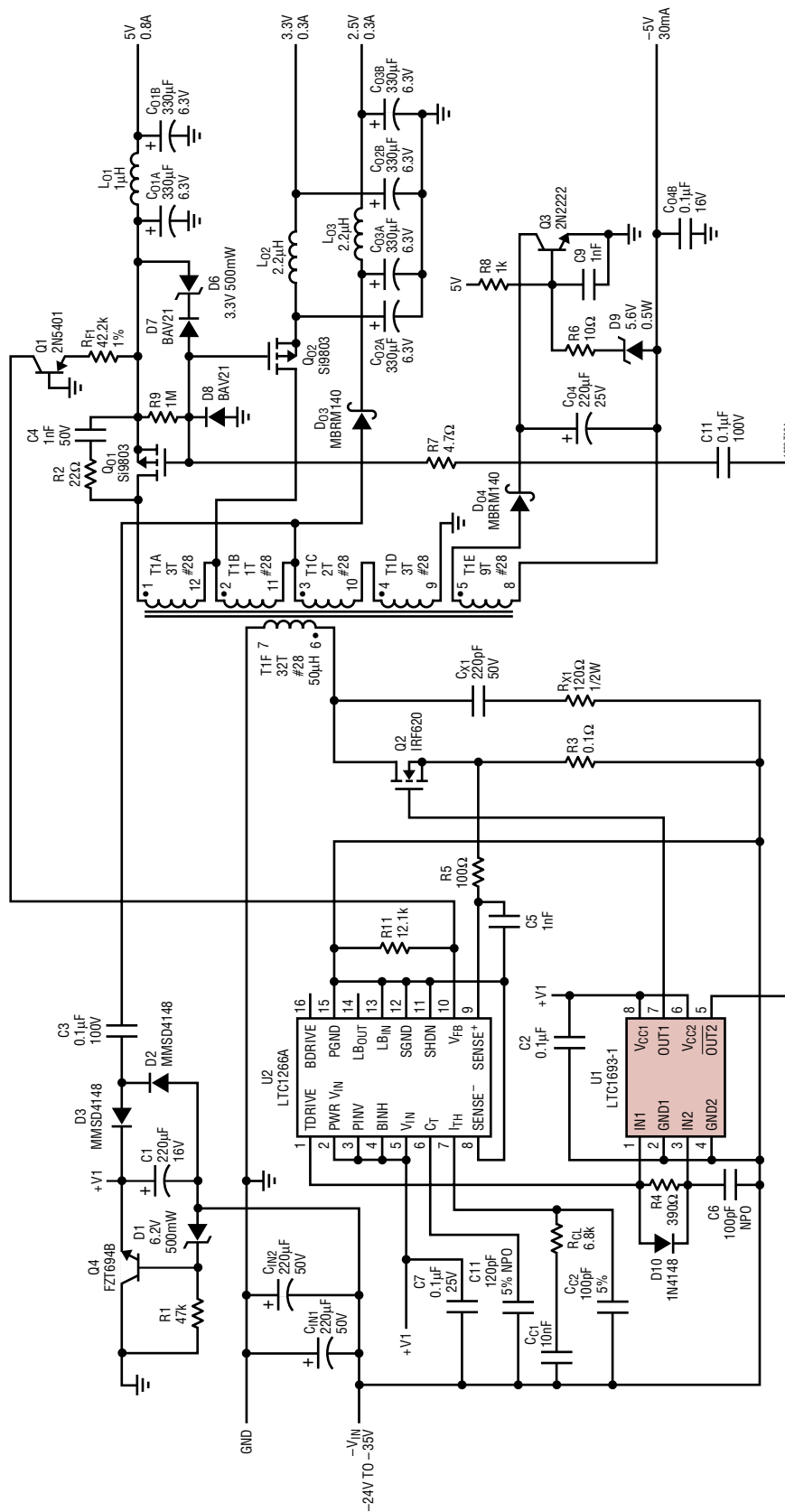

**T1 WINDING ORDER:**  
 1. T1A, T1B, T1C, T1D, QUAD-FILAR, WOUND FIRST. AFTER T1A, T1B, T1C AND T1D WOUND, REMOVE 2 TURNS FROM T1B AND T1 TURN FROM T1C  
 2. T1E WOUND ON TOP, SPREAD EVENLY  
 3. LAYER OF INSULATION  
 4. T1F WOUND ON TOP, SPREAD EVENLY

**T1 CORE:**  
 COILTRONICS VP4-TYPE, AIR GAP 0.7mm or 2 x 0.35mm SPACERS  
 PRIMARY INDUCTANCE OF T1F = 50μH  
**ALTERNATIVE CORES:**  
 SIEMENS EFD20, N67 MATERIAL, TDK PC40-EPC17

T1 TRANSFORMER	
COILTRONICS VP4-TYPE	
WINDING #	AWG
T1A	3 28
T1B	1 28
T1C	2 28
T1D	3 28
T1E	9 28
T1F	32 28

TYPICAL APPLICATIONS

48V to 5V Isolated Synchronous Forward DC/DC Converter

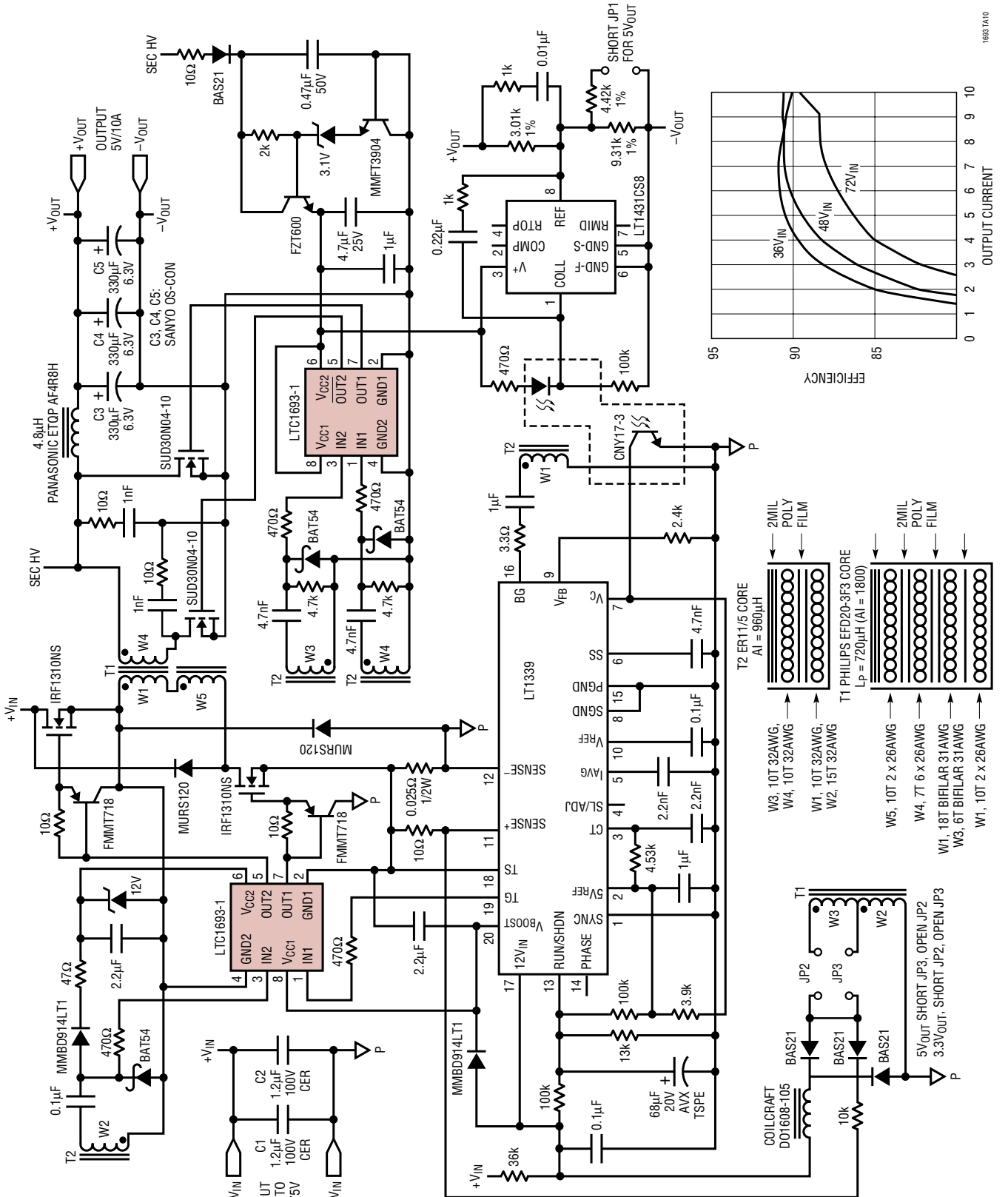

1693 TA10

TYPICAL APPLICATIONS

5V to 12V Boost Converter

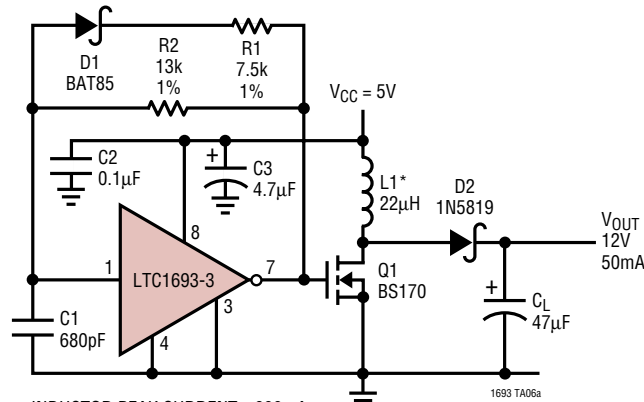

INDUCTOR PEAK CURRENT  $\approx$  600mA  
 R2, C1 SET THE OSCILLATION FREQUENCY AT 200kHz  
 R1 SETS THE DUTY CYCLE AT 45%  
 EFFICIENCY  $\approx$  80% AT 50mA LOAD  
 \*SUMIDA CDRH125-220

Output Voltage

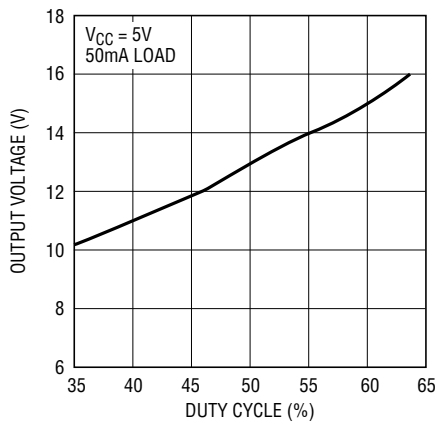

1693 TA06b

Efficiency

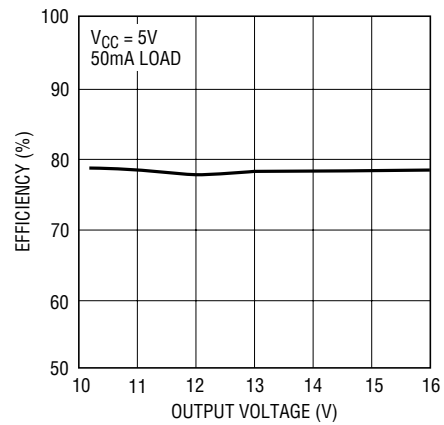

1693 TA06c

TYPICAL APPLICATIONS

Charge Pump Doubler

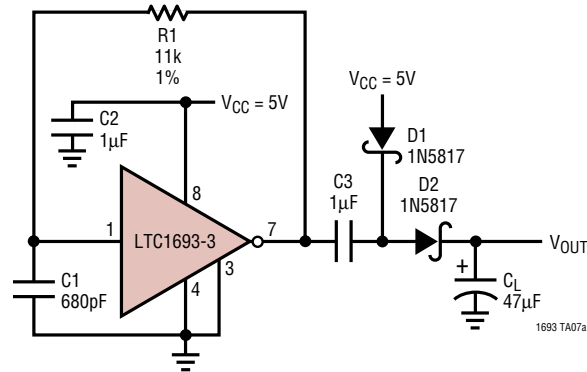

R1, C1 SET THE OSCILLATION FREQUENCY AT 150kHz AND THE DUTY CYCLE AT 35%

Output Voltage

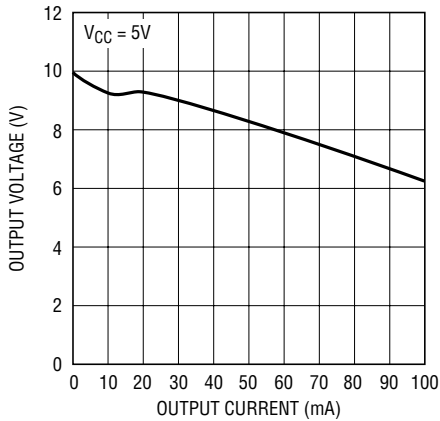

1693 TA07b

Efficiency

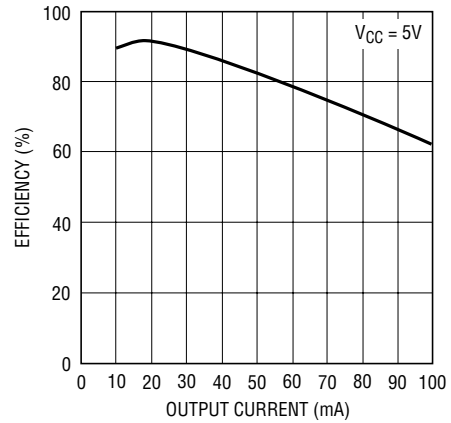

1693 TA07c



# TYPICAL APPLICATIONS

## Charge Pump Inverter

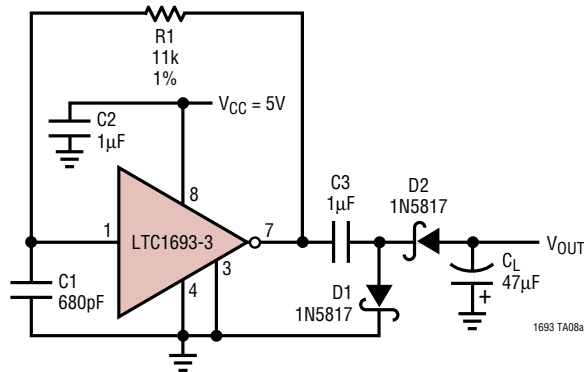

R1, C1 SET THE OSCILLATION FREQUENCY AT 150kHz AND THE DUTY CYCLE AT 35%

### Output Voltage

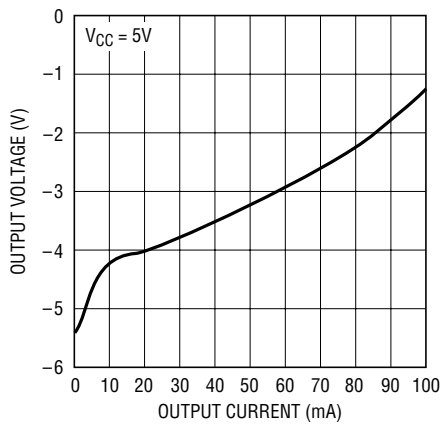

1693 TA08b

### Efficiency

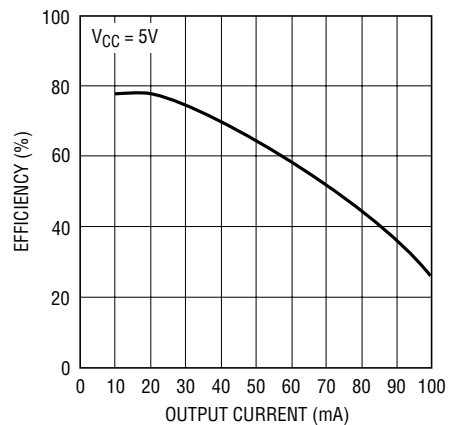

1693 TA08c

TYPICAL APPLICATIONS

Charge Pump Tripler

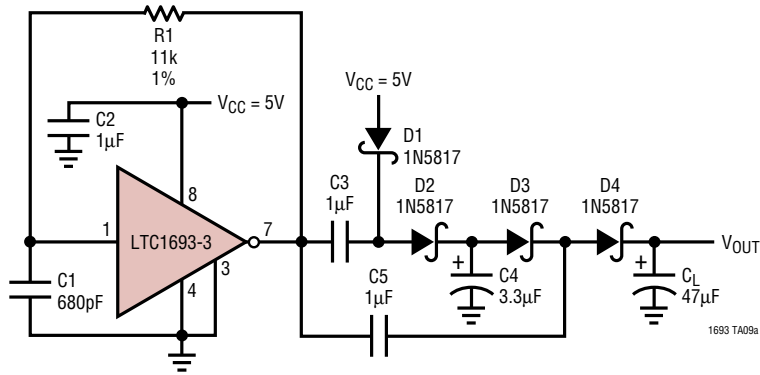

R1, C1 SET THE OSCILLATION FREQUENCY AT 150kHz AND THE DUTY CYCLE AT 35%

Output Voltage

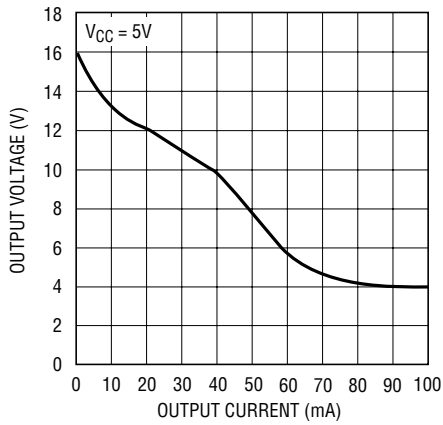

1693 TA09b

Efficiency

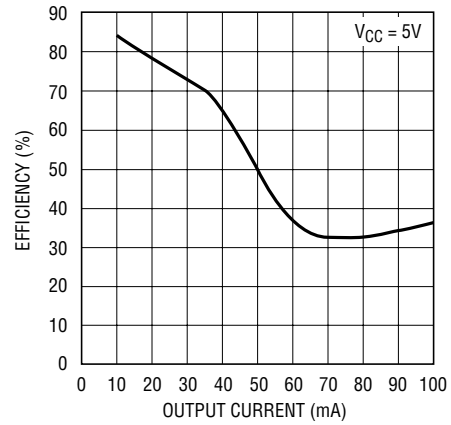

1693 TA09c

**PACKAGE DESCRIPTION** Dimensions in inches (millimeters) unless otherwise noted.

**MS8 Package**  
**8-Lead Plastic MSOP**  
 (LTC DWG # 05-08-1660)

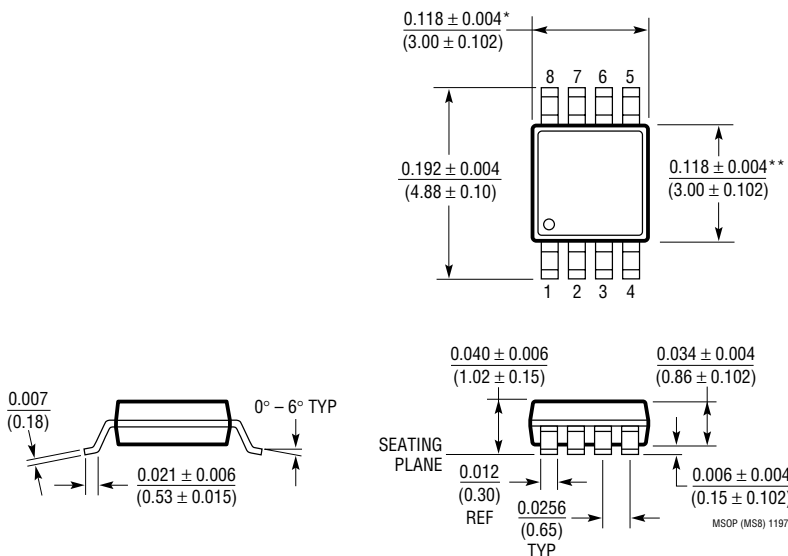

\* DIMENSION DOES NOT INCLUDE MOLD FLASH, PROTRUSIONS OR GATE BURRS. MOLD FLASH, PROTRUSIONS OR GATE BURRS SHALL NOT EXCEED 0.006\* (0.152mm) PER SIDE  
 \*\* DIMENSION DOES NOT INCLUDE INTERLEAD FLASH OR PROTRUSIONS. INTERLEAD FLASH OR PROTRUSIONS SHALL NOT EXCEED 0.006\* (0.152mm) PER SIDE

**S8 Package**  
**8-Lead Plastic Small Outline (Narrow 0.150)**  
 (LTC DWG # 05-08-1610)

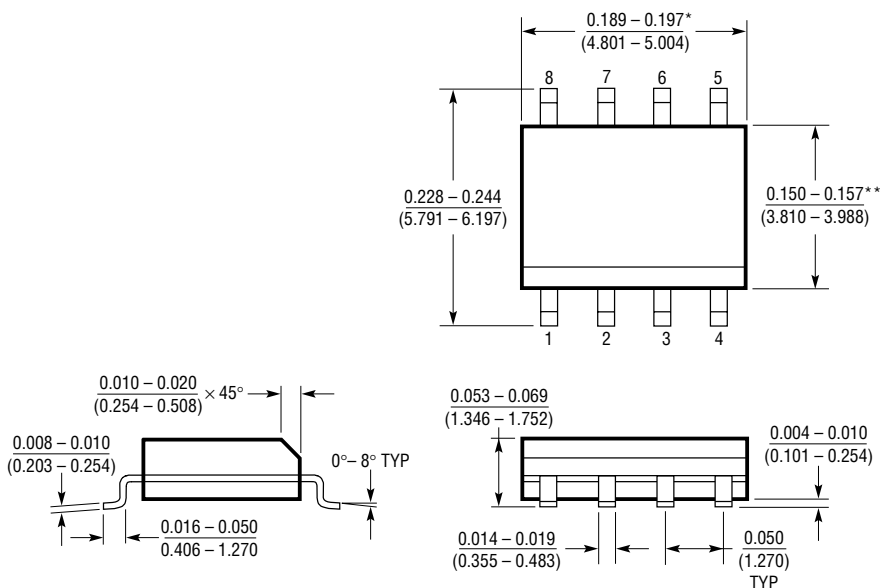

\* DIMENSION DOES NOT INCLUDE MOLD FLASH. MOLD FLASH SHALL NOT EXCEED 0.006\* (0.152mm) PER SIDE  
 \*\* DIMENSION DOES NOT INCLUDE INTERLEAD FLASH. INTERLEAD FLASH SHALL NOT EXCEED 0.010\* (0.254mm) PER SIDE

S08 0996

## TYPICAL APPLICATION

### Isolated Push-Pull DC/DC Converter

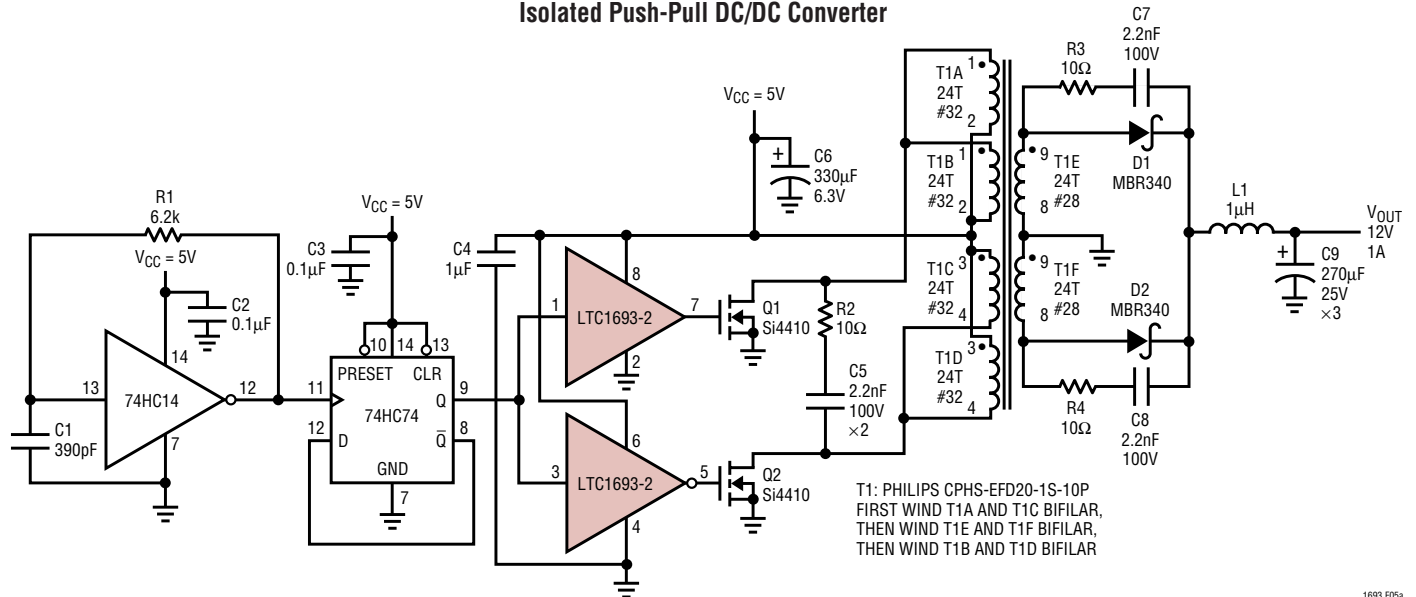

**Output Voltage**

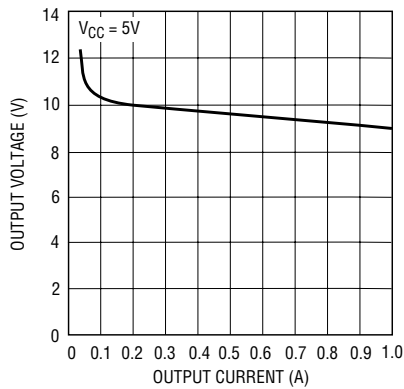

1693 F05b

**Efficiency**

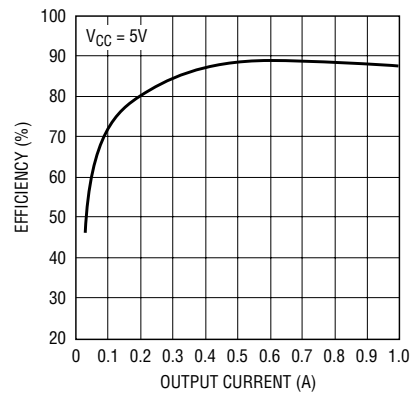

1693 F05c

## RELATED PARTS

PART NUMBER	DESCRIPTION	COMMENTS
LTC1154	High Side Micropower MOSFET Drivers	Internal Charge Pump, 4.5V to 48V Supply Range, $t_{ON} = 80\mu s$ , $t_{OFF} = 28\mu s$
LTC1155	Dual Micropower High/Low Side Drivers with Internal Charge Pump	4.5V to 18V Supply Range
LTC1156	Dual Micropower High/Low Side Drivers with Internal Charge Pump	4.5V to 18V Supply Range
LTC1157	3.3V Dual Micropower High/Low Side Driver	3.3V or 5V Supply Range
LT <sup>®</sup> 1160/LT1162	Half/Full Bridge N-Channel Power MOSFET Driver	Dual Driver with Topside Floating Driver, 10V to 15V Supply Range
LT1161	Quad Protected High Side MOSFET Driver	8V to 48V Supply Range, $t_{ON} = 200\mu s$ , $t_{OFF} = 28\mu s$
LTC1163	Triple 1.8V to 6V High Side MOSFET Driver	1.8V to 6V Supply Range, $t_{ON} = 95\mu s$ , $t_{OFF} = 45\mu s$
LT1339	High Power Synchronous DC/DC Controller	Current Mode Operation Up to 60V, Dual N-Channel Synchronous Drive
LTC1435	High Efficiency, Low Noise Current Mode Step-Down DC/DC Controller	3.5V to 36V Operation with Ultrahigh Efficiency, Dual N-Channel MOSFET Synchronous Drive



Компания «ЭлектроПласт» предлагает заключение долгосрочных отношений при поставках импортных электронных компонентов на взаимовыгодных условиях!

Наши преимущества:

- Оперативные поставки широкого спектра электронных компонентов отечественного и импортного производства напрямую от производителей и с крупнейших мировых складов;
- Поставка более 17-ти миллионов наименований электронных компонентов;
- Поставка сложных, дефицитных, либо снятых с производства позиций;
- Оперативные сроки поставки под заказ (от 5 рабочих дней);
- Экспресс доставка в любую точку России;
- Техническая поддержка проекта, помощь в подборе аналогов, поставка прототипов;
- Система менеджмента качества сертифицирована по Международному стандарту ISO 9001;
- Лицензия ФСБ на осуществление работ с использованием сведений, составляющих государственную тайну;
- Поставка специализированных компонентов (Xilinx, Altera, Analog Devices, Intersil, Interpoint, Microsemi, Aeroflex, Peregrine, Syfer, Eurofarad, Texas Instrument, Miteq, Cobham, E2V, MA-COM, Hittite, Mini-Circuits, General Dynamics и др.);

Помимо этого, одним из направлений компании «ЭлектроПласт» является направление «Источники питания». Мы предлагаем Вам помощь Конструкторского отдела:

- Подбор оптимального решения, техническое обоснование при выборе компонента;
- Подбор аналогов;
- Консультации по применению компонента;
- Поставка образцов и прототипов;
- Техническая поддержка проекта;
- Защита от снятия компонента с производства.



#### Как с нами связаться

**Телефон:** 8 (812) 309 58 32 (многоканальный)

**Факс:** 8 (812) 320-02-42

**Электронная почта:** [org@eplast1.ru](mailto:org@eplast1.ru)

**Адрес:** 198099, г. Санкт-Петербург, ул. Калинина, дом 2, корпус 4, литера А.