

# AN-EVAL-2HS01G-300W-1

## 300 W 12 V 25 A SMPS demonstrator with ICE2HS01G

Application Note

### About this document

#### Scope and purpose

This document is a description of the 300 W 12 V 25 A 400 V<sub>DC</sub> input off-line half bridge LLC resonant converter demonstrator board using Infineon ICE2HS01G.

#### Intended audience

This document is intended for users of the ICE2HS01G who wish to design a very highly efficient and highly reliable half bridge (HB) LLC resonant converter for applications within PC SMPS, server SMPS, etc.

### Table of Contents

<b>About this document .....</b>	<b>1</b>
<b>Table of Contents.....</b>	<b>1</b>
<b>1 Abstract .....</b>	<b>3</b>
<b>2 Demonstrator board.....</b>	<b>3</b>
<b>3 Specifications of demonstrator board .....</b>	<b>5</b>
<b>4 Features of ICE2HS01G .....</b>	<b>5</b>
<b>5 Circuit description.....</b>	<b>6</b>
<b>6 Circuit Diagram and Components List .....</b>	<b>7</b>
6.1 Schematics.....	7
6.1.1 Power Circuit Diagram .....	7
6.1.2 Control Circuit diagram.....	8
6.2 PCB Layout.....	9
6.3 Components List .....	10
<b>7 Transformer Construction.....</b>	<b>13</b>
7.1 Mains Transformer, TR100 .....	13
7.2 LLC Resonant Choke, L100 .....	14



**Abstract**

7.3 Pulse Transformer, TR101 .....14

**8 Electrical Test Results ..... 16**

8.1 Efficiency Measurements.....16

**9 Test waveforms ..... 17**

9.1 Soft start at full load and light load .....17

9.1.1 Full load .....17

9.1.2 No load.....17

9.2 Burst mode operation at no load .....18

9.3 SR soft start at full load .....18

9.4 SR Driver on-time .....19

9.4.1 Full load .....19

9.4.2 Light Load (Load = 1 A) .....19

9.5 Zero Voltage Switching.....20

9.5.1 Full load .....20

9.5.2 Light load (Load = 1 A) .....20

9.6 Main under voltage protection .....21

9.7 Dynamic load response .....22

9.7.1 12 V @ 2.5 A ~ 20 A, 5 kHz, 800 mA/μs .....22

9.7.2 12 V@ 2.5 A~20 A, 100 Hz, 800m A/μs.....22

9.8 Hold up time test.....23

**10 References ..... 24**

**Revision History..... 24**

## Abstract

### 1 Abstract

The evaluation board presented in this application note is a 300 W LLC Converter with 400 V<sub>DC</sub> input and 12 V output. It is controlled by Infineon's 2nd generation half-bridge LLC controller ICE2HS01G. The ICE2HS01G is specially designed for high efficiency applications with synchronous rectification (SR) control on the secondary side. With new driving techniques, SR can be realized for a half-bridge LLC converter operated with secondary switching current in both CCM and DCM conditions.

In this application note, the schematic circuit, PCB layout and BOM for the evaluation board are shown, followed by the performance parameters, such as efficiency and operation waveforms. For the detailed step-by-step design procedure of this converter, please refer to our design guide [5].

### 2 Demonstrator board

The 300W half bridge LLC resonant converter demo board with ICE2HS01G is implemented as shown in Figures 1 and 2. The LLC stage's full load efficiency reaches >97%.

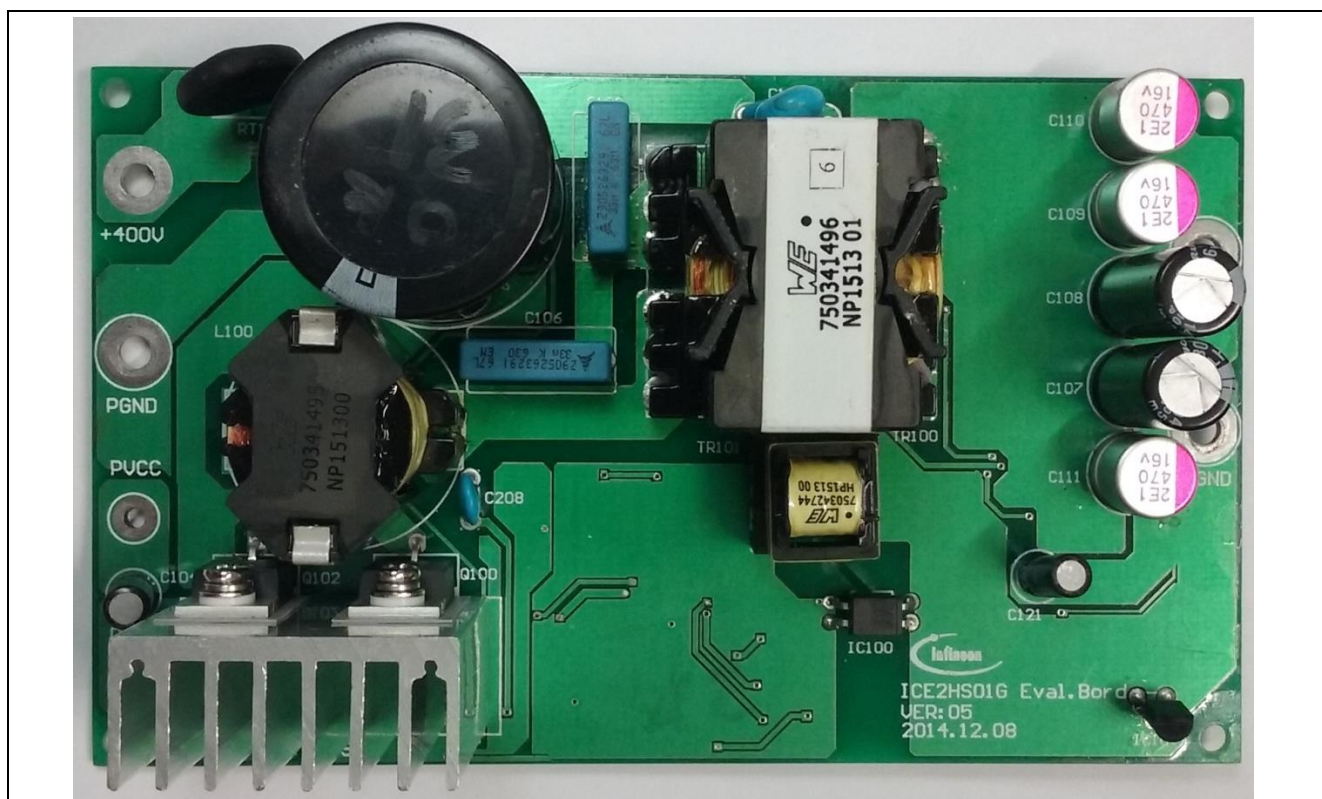

Figure 1 EVAL-2HS01G-300W-1 half bridge LLC resonant converter (top view)

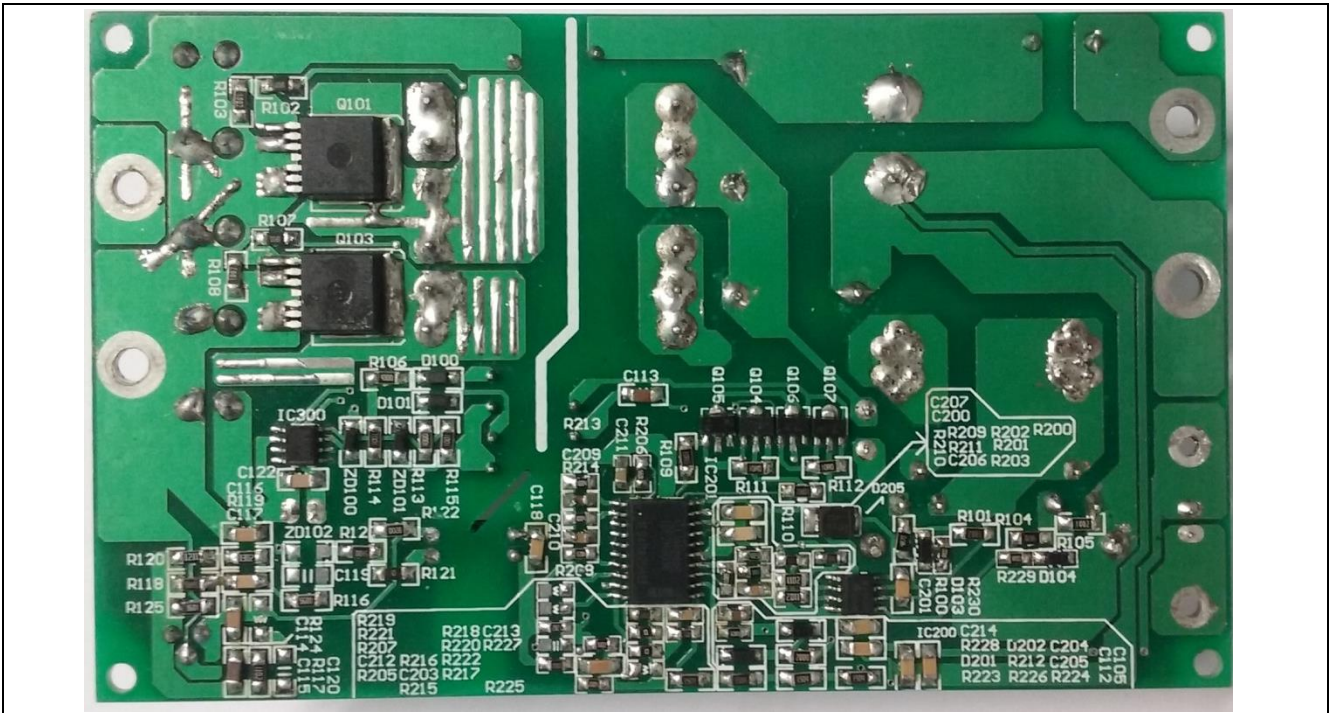

Figure 2 EVAL-2HS01G-300W-1 half bridge LLC resonant converter (bottom view)

---

**Specifications of demonstrator board**

### 3 Specifications of demonstrator board

**Table 1 Specifications of EVAL-2HS01G-300W-1**

Nominal DC Input voltage	400 V <sub>DC</sub>
Mains under voltage protection point	368 V <sub>DC</sub>
Auxiliary power supply for IC V <sub>CC</sub>	15 V <sub>DC</sub>
Nominal output full load	12 V 25 A (300W)
Efficiency $\eta$	>97% at 100% load >97% at 50% load ~96% at 20% load
Switching frequency (Resonant frequency, $f_r$ )	85 kHz @ 12 V 25 A and 400 V <sub>DC</sub> input
Form factor case size (L x W x H)	140 mm x 85 mm x 35 mm

### 4 Features of ICE2HS01G

**Table 2 Features of ICE2HS01G**

Resonant mode controller for Half-bridge LLC resonant converter with synchronous rectification
20-pin DSO package
30 kHz to 1 MHz switching frequency
Adjustable minimum switching frequency with high accuracy
50% duty cycle for both primary and secondary gate drives
Adjustable dead time with high accuracy
Driving signal for synchronous rectification which supports full operation of a Half-bridge LLC resonant converter
Internal and External disable functions for synchronous rectification
Mains input under voltage protection with adjustable hysteresis
Three levels of overcurrent protection for enhanced dynamic performance
Open-loop/overload protection with adjustable blanking time and restart time
Adjustable over-temperature protection with latch-off
External latch-off enable pin

---

## Circuit description

### 5 Circuit description

For this evaluation board, only the LLC resonant converter circuit is implemented. Thus, a high voltage DC voltage should feed directly to the input “+400V” and “PGND” terminals. Additionally, a 15 V DC voltage needs to be applied to the “PVCC” and “PGNG” terminals to power up the controller ICs.

The input side comprises a NTC, RT100 and a bulk capacitor, C100. The NTC resistor is placed in series with the input to limit the initial peak inrush current. The bulk capacitor is used to smooth the ripple.

The second stage is a half bridge LLC resonant converter that is operating in zero voltage switching (ZVS) mode. The controller ICE2HS01G is a 20 pin LLC controller, which incorporates the necessary functions to drive the half bridge’s high side and low side MOSFETs (Q100 and Q102) by a 50% duty cycle with adjustable dead time. The switching frequency can be changed by ICE2HS01G to regulate the output voltage against the load and input voltage variations. During operation, the primary MOSFETs Q100 and Q102 (IPP60R190E6) are turned-on under a ZVS condition and the secondary synchronized MOSFETs Q101 and Q103 (IPB011N04N) are turned-on and turned-off under a ZCS condition. Hence, very high power conversion efficiency can be achieved.

The driver circuit is implemented by a 600 V half bridge gate driver IC, IC200 (2EDL05N06PF). As shown in Figure 4, the IC200 is a 0.5 A 600 V high voltage gate driver IC in an SO-8 package that is used to transmit and isolate the driver signal to the MOSFETs.

The mains transformer TR100 is used for power pulse transmission whereas a separate resonant choke, L100 is used for resonant purposes. The transformer configuration for the secondary winding is center-tapped and the output synchronized rectifiers MOSFET Q101 and Q103 can reduce the power dissipation and achieve very high efficiency. The synchronized MOSFETs are controlled by the ICE2HS01G through a signal pulse transformer TR101 and a dual MOSFET driver IC, IC300.

In the case of a short circuit, the current flowing through the primary winding is detected by the lossless circuit (C208, C214, D201, D202, R212, and R228) and the resulting signal is fed into the CS Pin of ICE2HS01G. In the case of an overload, the voltage on the CS pin will exceed an internal 0.8 V threshold that triggers a protection mode that keeps the current flowing in the circuit at a safe level. In addition, the blanking time and the restart time can be adjusted by external components.

There are some more control settings in the ICE2HS01G, such as main input under voltage protection, soft-start time, frequency setting, dead time setting, synchronized rectifier control, etc. Please refer to the datasheet and the design guide for details.

Circuit Diagram and Components List

## 6 Circuit Diagram and Components List

### 6.1 Schematics

#### 6.1.1 Power Circuit Diagram

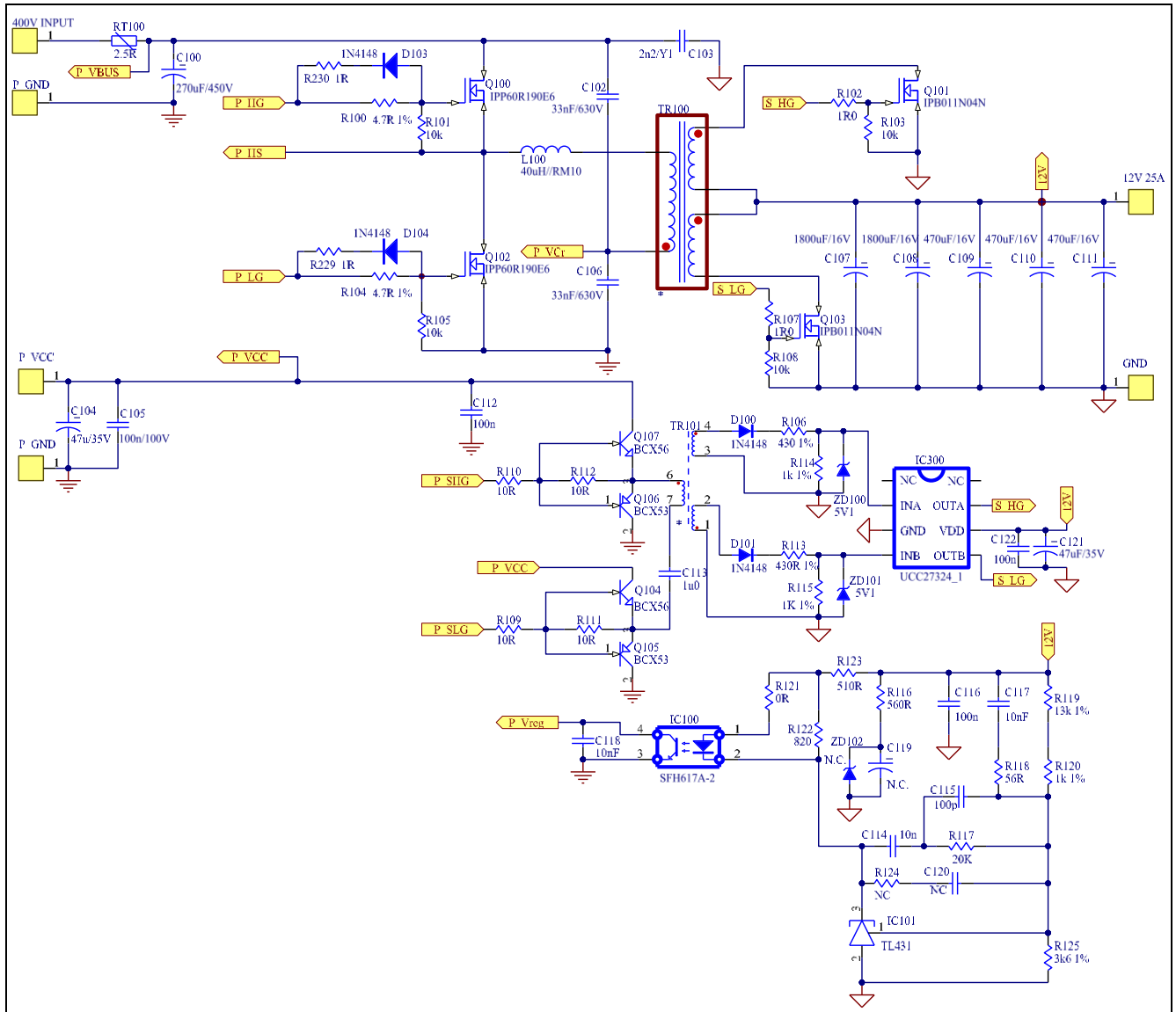

Figure 3 Schematics of 300 W half bridge LLC resonant – power circuit

Circuit Diagram and Components List

6.1.2 Control Circuit diagram

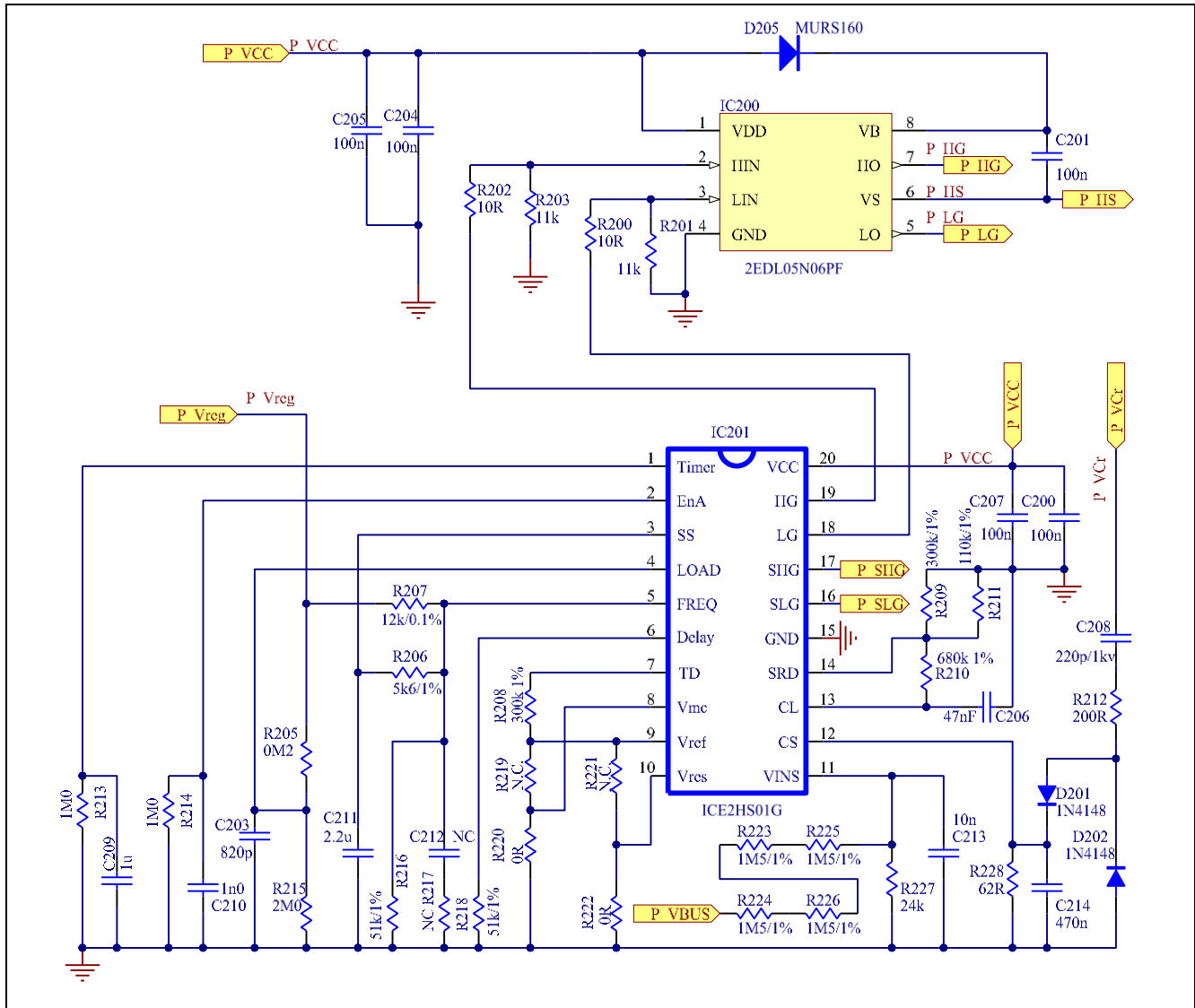

Figure 4 Schematics of 300 W half bridge LLC resonant – control circuit



Circuit Diagram and Components List

6.2 PCB Layout

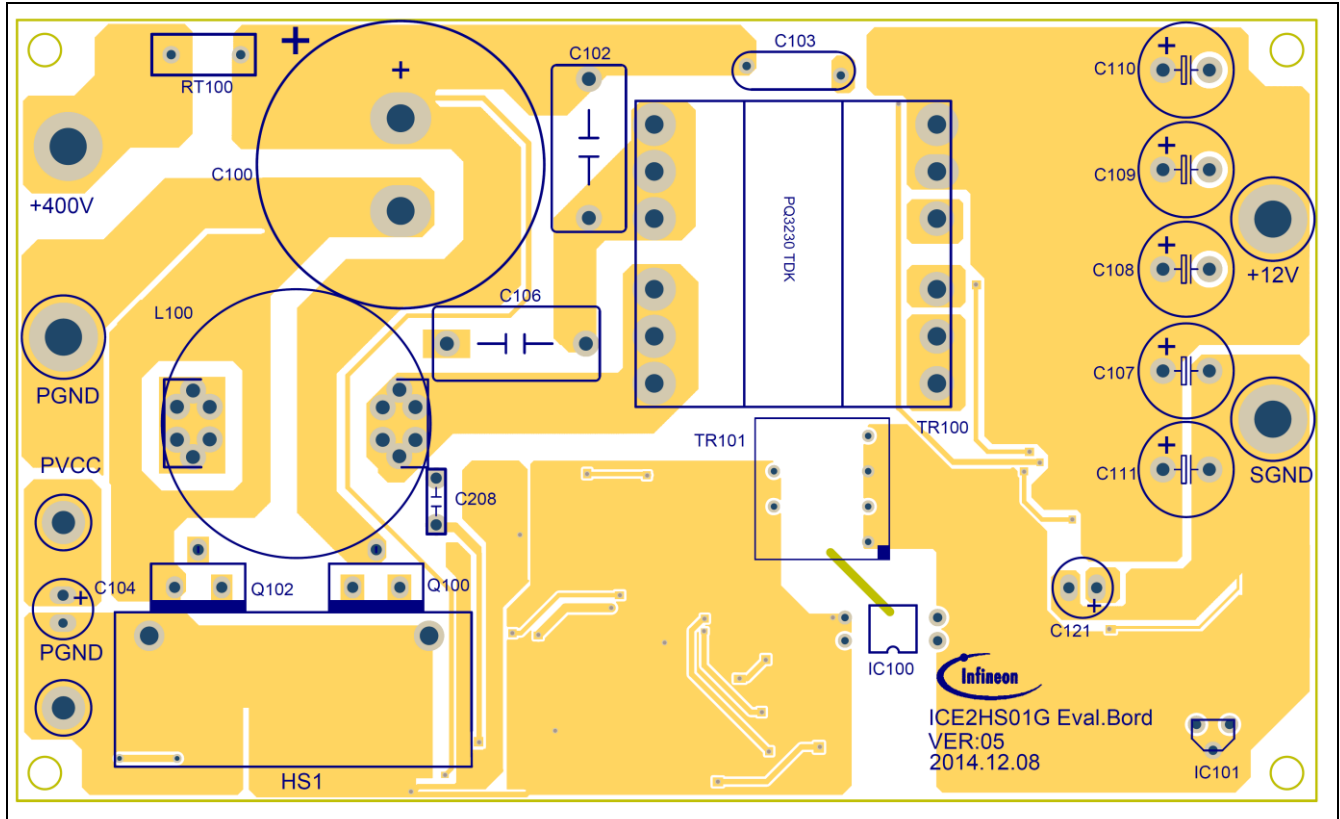

Figure 5 Component side copper – View from component side

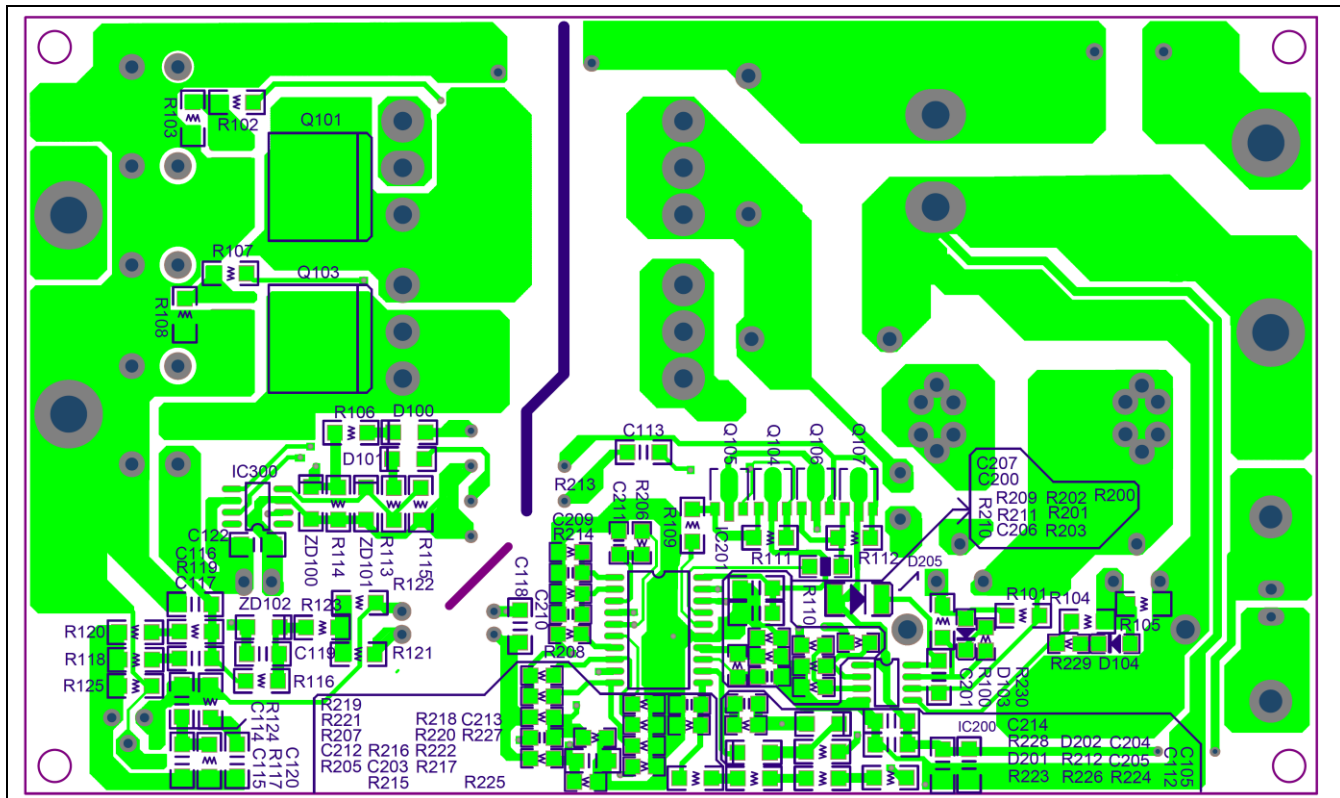

Figure 6 Solder side copper – View from solder side

## Circuit Diagram and Components List

## 6.3 Components List

Table 3 Bill of Materials

Item	Circuit Code	Part Value	Description	Footprint	Supplier
1	C100	270 uF/450 V	Aluminum Electrolyte	RB30	
2	C102	33 nF/630 V	CERAMIC	MKT6/13/10	
3	C103	2n2/Y1	CERAMIC	CY10	
4	C104	47 uF/35 V	Aluminum Electrolyte	RB6.5	
5	C105	100 nF/100 V	CERAMIC	1206C	
6	C106	33 nF/630 V	CERAMIC	MKT6/13/10	
7	C107	1800 uF/16 V	Aluminum Electrolyte	RB10	
8	C108	1800 uF/16 V	Aluminum Electrolyte	RB10	
9	C109	470 uF/16 V	Aluminum Electrolyte	RB10	
10	C110	470 uF/16 V	Aluminum Electrolyte	RB10	
11	C111	470 uF/16 V	Aluminum Electrolyte	RB10	
12	C112	100 nF	Ceramic	1206C	
13	C113	1u0	Ceramic	1206C	
14	C114	10 nF	Ceramic	1206C	
15	C115	330 pF	Ceramic	1206C	
16	C116	100 nF	Ceramic	1206C	
17	C117	10 nF	Ceramic	1206C	
18	C118	10 nF	Ceramic	1206C	
19	C119	NC	Aluminum Electrolyte	1206C	
20	C120	NC		1206C	
21	C121	47 uF/35 V	Aluminum Electrolyte	RB6.5	
22	C122	100 nF	Ceramic	MKT2/7/5	
23	C200	100 nF	Ceramic	MKT2/7/5	
24	C201	100 nF	Ceramic	MKT2/7/5_0M8	
25	C203	1n2	Ceramic	MKT2/7/5	
26	C204	100 nF	Ceramic	MKT2/7/5_0M8	
27	C205	100 nF	Ceramic	MKT2/7/5	
28	C206	47 nF	Ceramic	0805C	
29	C207	100 nF	Ceramic	MKT2/7/5_0M8	
30	C208	220 pF/1 kV	Ceramic	MKT2/7/5	
31	C209	1 uF	Ceramic	0805C	
32	C210	1n0	Ceramic	0805C	
33	C211	2.2 uF	Ceramic	0805C	
34	C212	NC	Ceramic	0805C	
35	C213	10 nF	Ceramic	0805C	
36	C214	470 nF	Ceramic	0805C	
37	D100	1N4148	Diode	1206D	
38	D101	1N4148	Diode	1206D	
39	D103	1N4148	Diode	1206D	

**Circuit Diagram and Components List**

40	D104	1N4148	Diode	1206D	
41	D201	1N4148	Diode	1206D	
42	D202	1N4148	Diode	1206D	
43	D205	MURS160T3	Diode	SMB	
44	IC100	SFH617A-2	Opto Coupler	DIP4/10	
45	IC101	TL431	Error Amplifier	TO92-CBE	
46	IC200	2EDL05N06PF	Half-bridge MOSFET driver	SO-8	Infineon
47	IC201	ICE2HS01G	Resonant-Mode Controller	SOL-20	Infineon
48	IC300	UCC27324_1	MOSFET driver	SO-8	
49	L100	40 uH/RM10	LLC Resonant CHOKE	RM10	WE 750341495
50	PCB	Double Layer	2 ounce copper		
51	Q100	IPP60R190E6	MOSFET	T0-220	Infineon
52	Q101	IPB011N04N	MOSFET	TO-263	Infineon
53	Q102	IPP60R190E6	MOSFET	T0-220	Infineon
54	Q103	IPB011N04N	MOSFET	TO-263	Infineon
55	Q104	BCX56	NPN Transistor	SOT-89	
56	Q105	BCX53	PNP Transistor	SOT-89	
57	Q106	BCX53	PNP Transistor	SOT-89	
58	Q107	BCX56	NPN Transistor	SOT-89	
59	R100	4R7	Resistor	1206R	
60	R101	10 k	Resistor	1206R	
61	R102	1R0	Resistor	1206R	
62	R103	10 k	Resistor	1206R	
63	R104	4R7	Resistor	1206R	
64	R105	10 k	Resistor	1206R	
65	R106	430R	Resistor	1206R	
66	R107	1R0	Resistor	1206R	
67	R108	10 k	Resistor	1206R	
68	R109	10 R	Resistor	1206R	
69	R110	10 R	Resistor	1206	
70	R111	10 R	Resistor	1206R	
71	R112	10 R	Resistor	1206R	
72	R113	430 R	Resistor	1206R	
73	R114	1 k	Resistor	1206R	
74	R115	1 k	Resistor	1206R	
74	R116	560 R	Resistor	1206R	
75	R117	11 k	Resistor	1206R	
76	R118	56 R	Resistor	1206R	
77	R119	13 k	Resistor	1206R	
78	R120	1 k	Resistor	1206R	
79	R121	0 R	Resistor	1206R	
80	R122	820 R	Resistor	1206R	

Circuit Diagram and Components List

81	R123	510 R	Resistor	1206R	
82	R124	NC	Resistor	1206R	
83	R125	3k6	Resistor	1206R	
84	R200	10 R	Resistor	0805r	
85	R202	10 R	Resistor	0805r	
86	R203	11 k	Resistor	0805r	
87	R203	11 k	Resistor	0805r	
88	R205	200 k	Resistor	0805r	
89	R206	5k6/1%	Resistor	0805r	
90	R207	12 k/0.1%	Resistor	0805r	
91	R208	402 k	Resistor	0805R	
92	R209	300 k	Resistor	0805r	
93	R210	680 k	Resistor	0805r	
94	R211	110 k/1%	Resistor	0805r	
95	R212	200 R	Resistor	1206R	
96	R213	1M0	Resistor	0805r	
97	R214	1M0	Resistor	0805r	
98	R215	2M0	Resistor	0805r	
99	R216	51 k/1%	Resistor	0805r	
100	R217	NC	Resistor	0805r	
101	R218	51 k/1%	Resistor	0805r	
102	R219	NC	Resistor	0805r	
103	R220	0R	Resistor	0805r	
104	R221	NC	Resistor	0805r	
105	R222	0 R	Resistor	0805r	
106	R223	1M5/1%	Resistor	1206R	
107	R224	1M5/1%	Resistor	1206R	
108	R225	1M5/1%	Resistor	1206R	
109	R226	1M5/1%	Resistor	1206R	
110	R227	24 k	Resistor	0805R	
111	R228	62 R	Resistor	0805R	
112	R229	1R0	Resistor	1206R	
113	R230	1R0	Resistor	1206R	
114	RT100	2R5	NTC Thermister	NTC7.5	
115	TR100	Lp=690 uH	LLC Resonant Transformer	PQ3230	WE 750341496
116	TR101	Lp=2.8 mH (min)	Pulse Transformer_Wurth	EE13	WE 750342744
117	ZD100	5V1	Zener Diode	1206D	
118	ZD101	5V1	Zener Diode	1206D	
119	ZD102	NC	Zener Diode	1206D	

Transformer Construction

## 7 Transformer Construction

### 7.1 Mains Transformer, TR100

- Core: PC95 PQ3230 (TDK) (WE 750341496)
- Primary inductance  $L_p$ : 690  $\mu\text{H} \pm 3\%$ , between Pin 3 and Pin 4 (Gapped)
- Leakage inductance: <2% of  $L_p$  with either Pin 7&11 shorted or Pin 9&11 shorted
- Teflon tube used for the pinout.

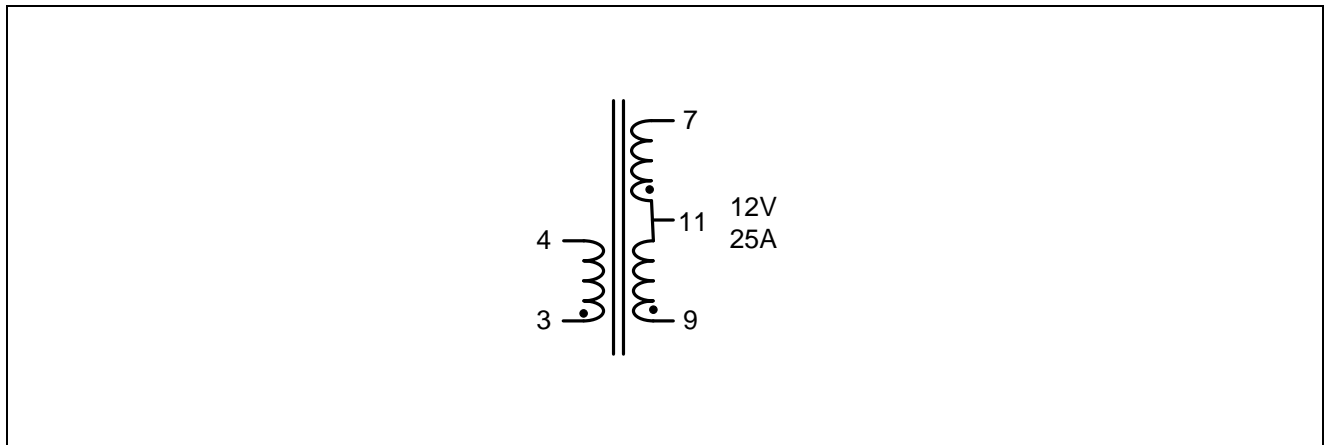

Figure 7 LLC resonant transformer electrical diagram

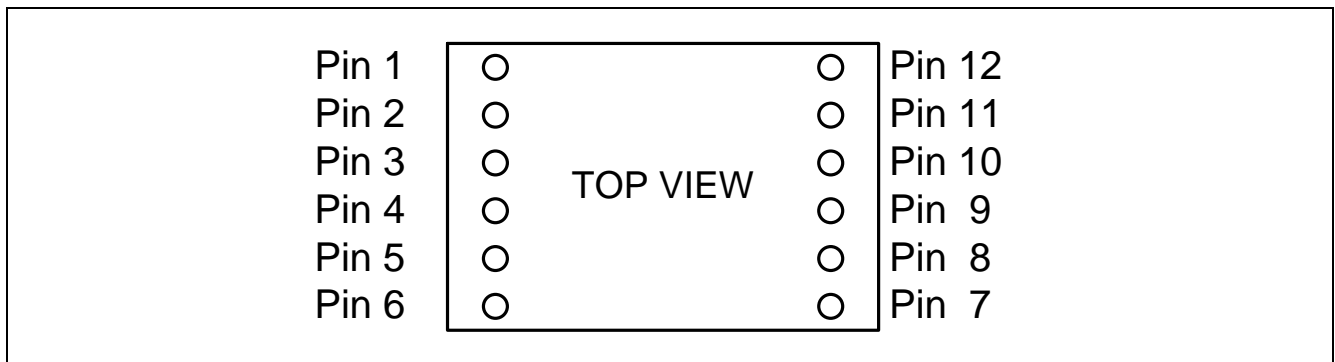

Figure 8 LLC resonant transformer complete - top view

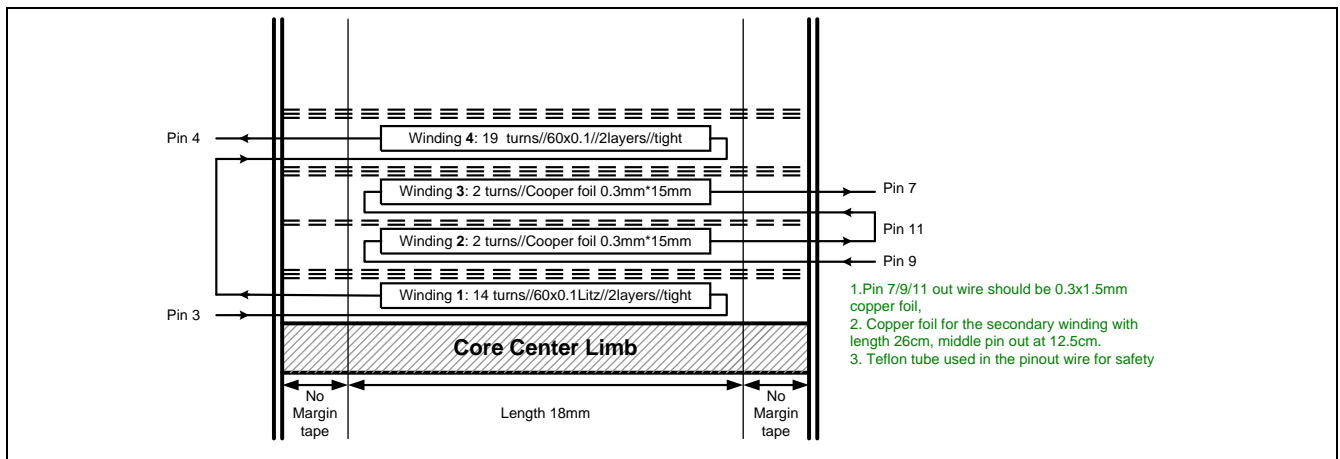

Figure 9 LLC resonant transformer winding position

**Transformer Construction**

**Table 4 LLC resonant transformer winding characteristics**

<i>Windings</i>	<i>Start</i>	<i>End</i>	<i>Wire</i>	<i>Turns</i>	<i>Layers</i>	<i>Method</i>
1	3	float	60x0.1mm Litz	14	2	Tight
2	9	11	0.3mm*15mm	2	NA	Tight
3	11	7	0.3mm*15mm	2	NA	Tight
4	float	4	60x0.1mm Litz	19	2	Tight

**7.2 LLC Resonant Choke, L100**

- Core: RM10 (WE 750341495)
- Material: N87
- Inductance: L=40 uH

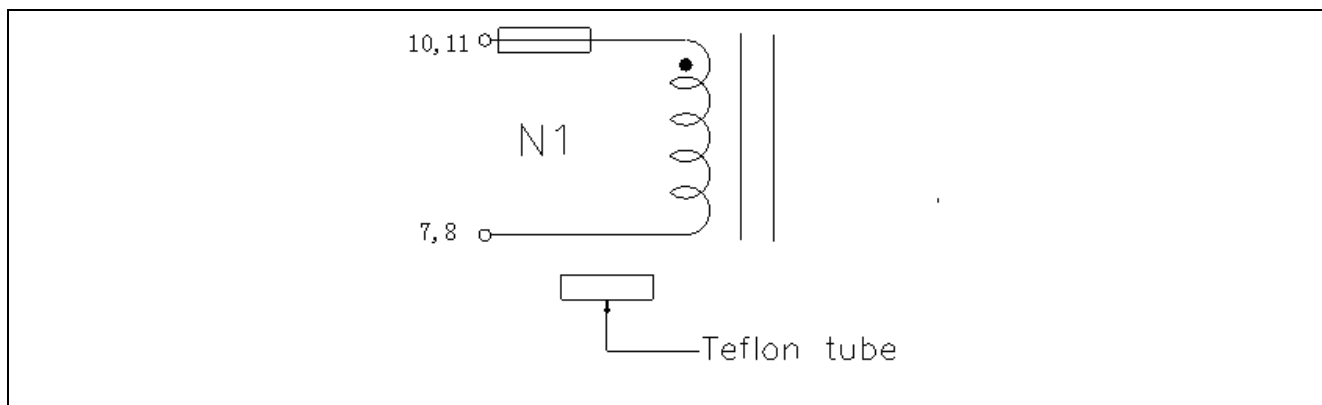

**Figure 10 LLC resonant transformer electrical diagram**

**Table 5 LLC resonant transformer winding characteristics**

Windings	Start-End	Wire	Turns	Method
N1	10,11 — 7,8	2UEW, φ0.10 mm *50p	44	tight

**7.3 Pulse Transformer, TR101**

- Core: EE13 (WE 750342744)
- Material: Ferrite
- Inductance: 2.8 mH Min (no gap)

Transformer Construction

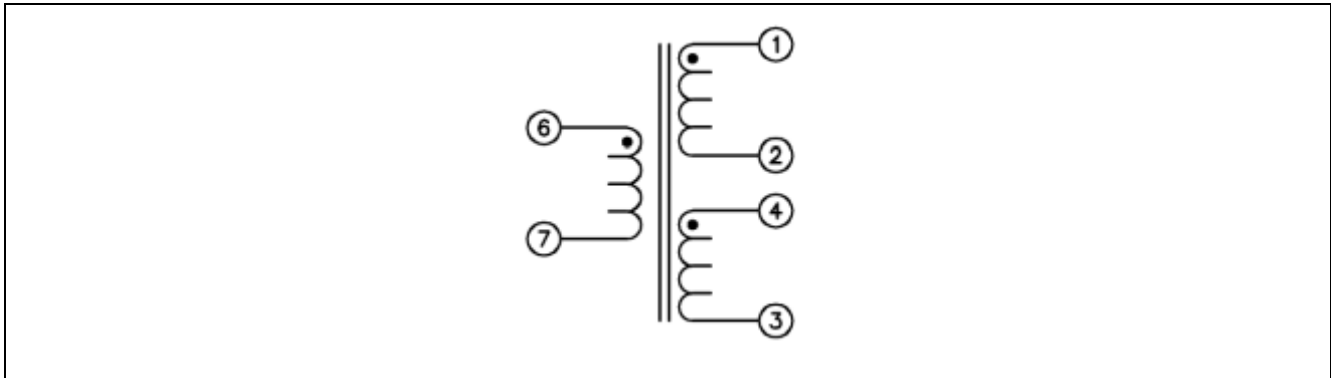

Figure 11 Pulse Transformer electrical diagram

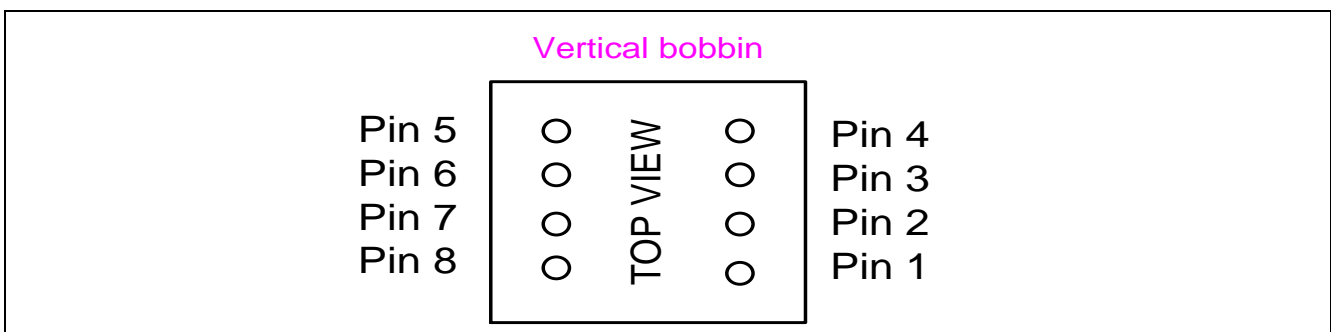

Figure 12 Pulse transformer complete - top view

Table 6 Pulse transformer winding characteristics

Winding	Start	Finish	Wire	Turns(Ts)	Winding
N1	1	2	TLW-B, $\Phi 0.20$ mm*1P	35TS	
N2	4	3	TLW-B, $\Phi 0.20$ mm*1P	35TS	
N3	6	7	TLW-B, $\Phi 0.11$ mm*1P	60TS	

## Electrical Test Results

# 8 Electrical Test Results

## 8.1 Efficiency Measurements

Table 7 shows the output voltage measurements at the nominal input voltage of 400 V<sub>DC</sub>, with different load conditions. The input voltage 400 V<sub>DC</sub> is supplied from a high voltage DC power supply and auxiliary voltage 15 V are applied to the PVCC pin. The RT100 (NTC) is shorted during the test. Before the measurement, 20 ~ 30 minutes burn-in are performed.

**Table 7 Efficiency measurements @ input voltage =400 V<sub>DC</sub>**

V <sub>out</sub> (V)	I <sub>out</sub> (A)	P <sub>out</sub> (W)	Load(%)	V <sub>in</sub> (V)	I <sub>in</sub> (A)	P <sub>in</sub> (W)	V <sub>cc</sub> (V)	I <sub>vcc</sub> (A)	P <sub>vcc</sub> (W)	Eff.(%)
12.224	1.254	15.329	5%	399.95	0.0430	17.573	15	0.025	0.375	87.23
12.226	2.508	30.663	10%	399.97	0.0814	32.933	15	0.025	0.375	93.11
12.226	5.004	61.179	20%	400.07	0.1581	63.626	15	0.025	0.375	96.15
12.225	12.508	152.910	50%	400.38	0.3903	156.643	15	0.025	0.375	97.62
12.217	25.006	305.498	100%	400.04	0.7840	314.006	15	0.025	0.375	97.29

The power losses due to the IC and driver circuits are both included. Efficiency values were measured after 30 minutes of warm-up at full load.

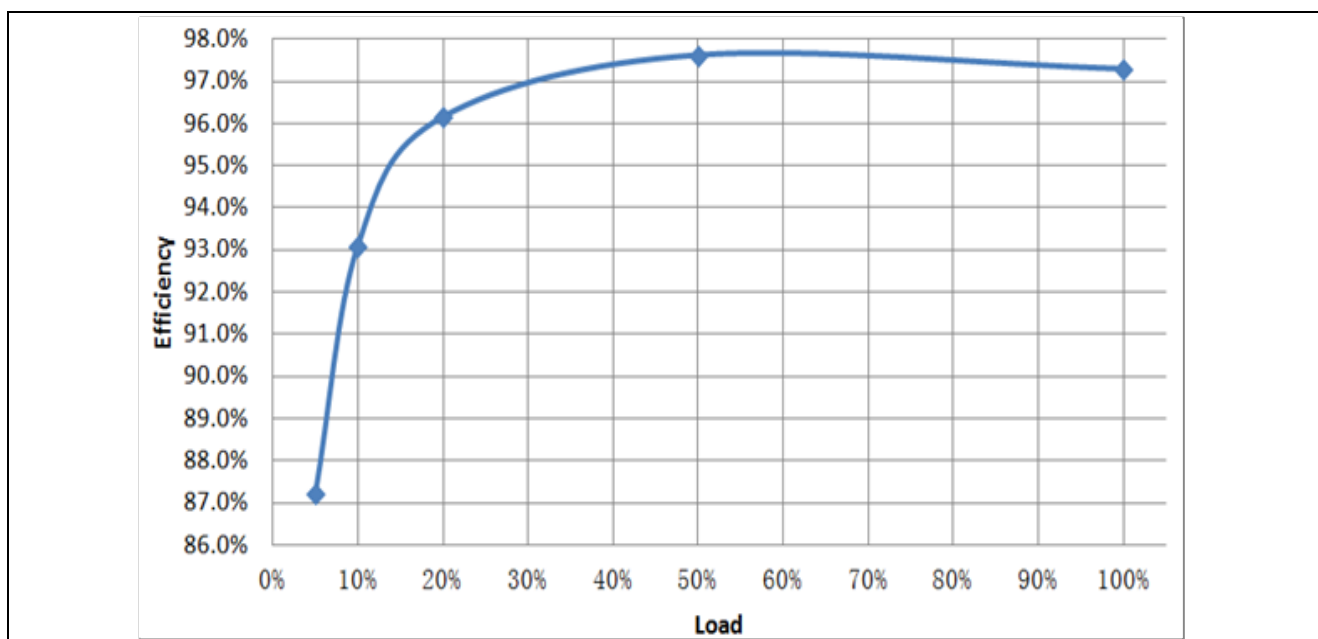

**Figure 13 LLC stage efficiency**



Test waveforms

## 9 Test waveforms

### 9.1 Soft start at full load and light load

#### 9.1.1 Full load

The output voltage rises to nominal value in around 12 ms and the output overshoot is less than 5%. The soft start is achieved by decreasing the switching frequency gradually from 280 kHz to 80 kHz until stable operation is reached.

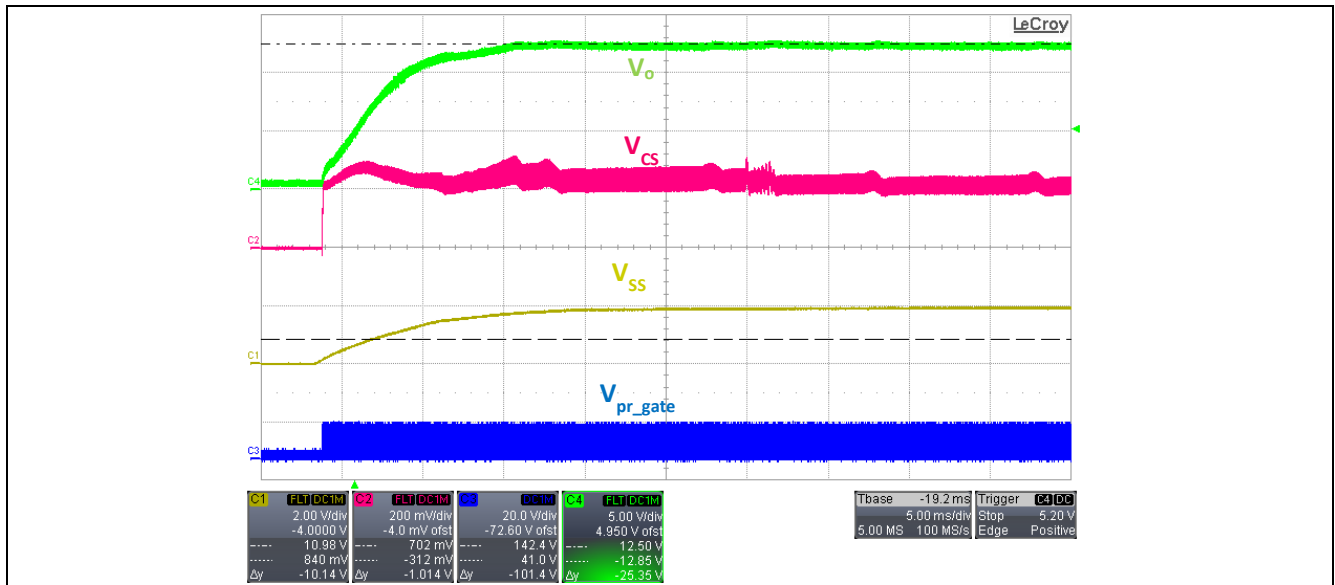

Figure 14 Full load

#### 9.1.2 No load

The output voltage rises to nominal value in around 5 ms and the output overshoot is less than 5%. The IC operates in burst mode after soft-start.

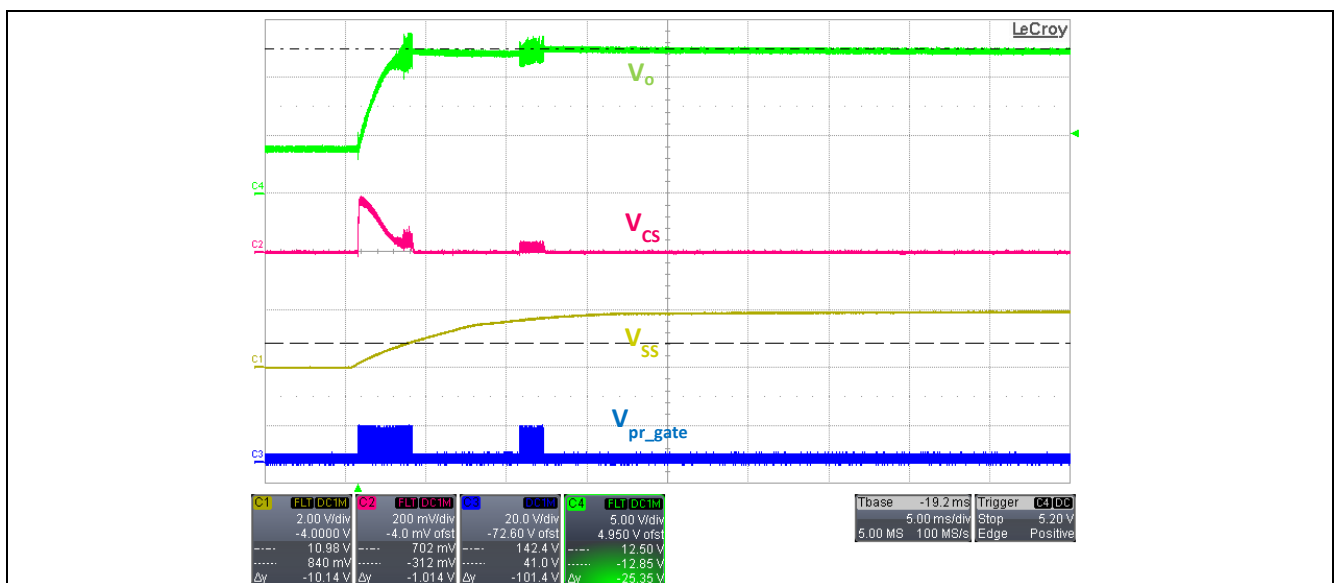

Figure 15 No load

Test waveforms

### 9.2 Burst mode operation at no load

When the IC is operating in burst mode, the ripple of out voltage is less than 250 mV.

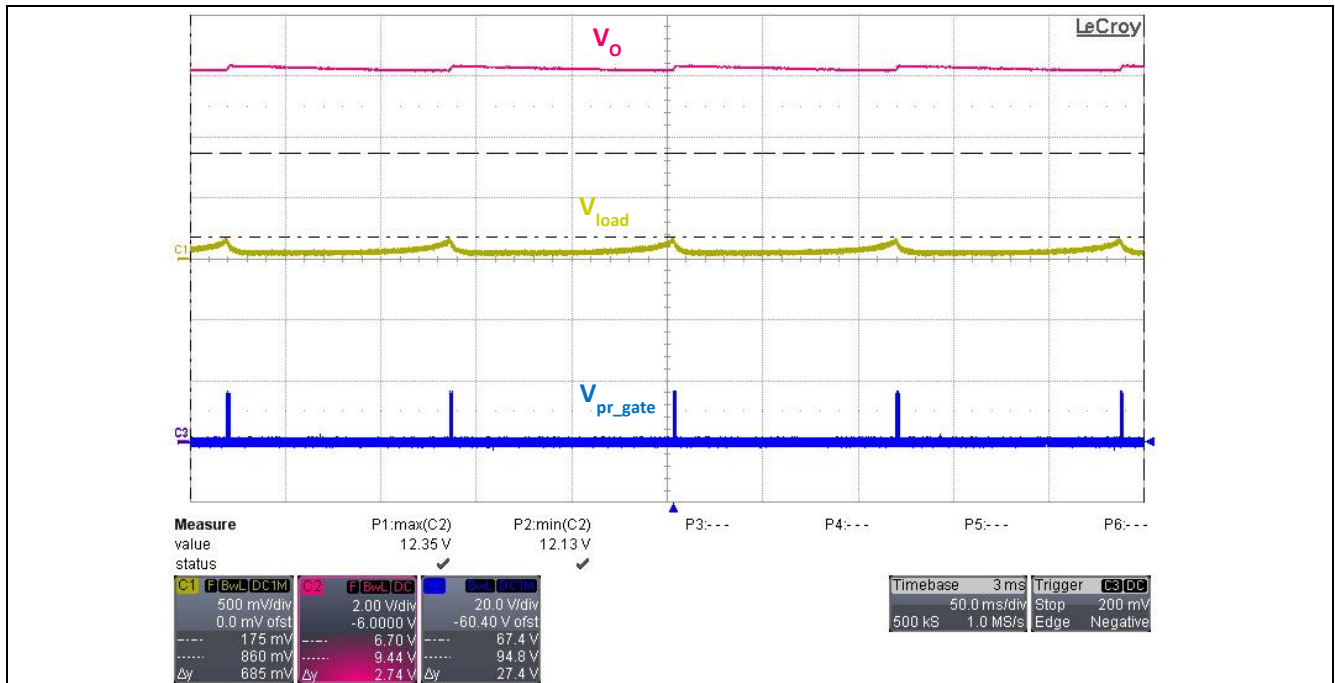

Figure 16 Burst mode operation at no load

### 9.3 SR soft start at full load

The SR operation is enabled after the output voltage has risen. In ICE2HS01G, SR operation will start with a small duty cycle, around one-tenth of its normal duty cycle, which will be kept the same for 16 consecutive switching cycles. Then, the duty cycle is gradually increased in steps to the full duty cycle. A total of 7 steps are built in for the soft-start and each step includes 16 switching cycles.

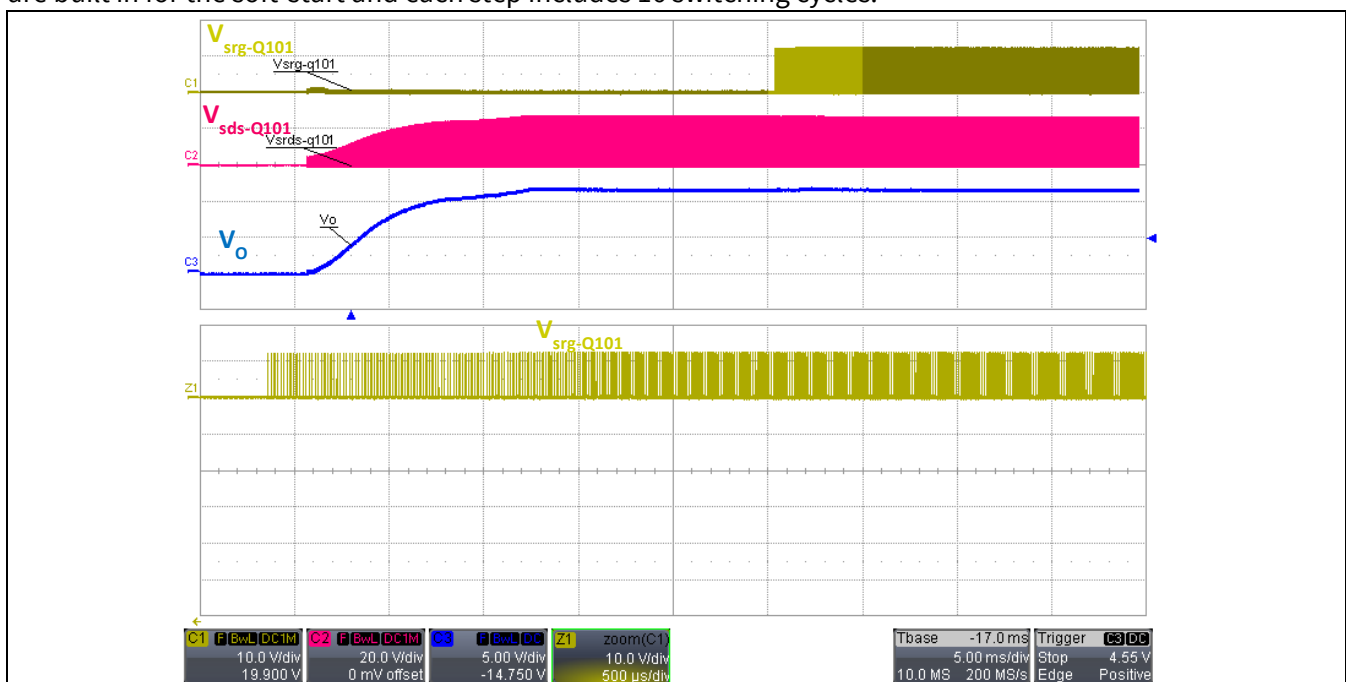

Figure 17 SR soft start at full load

Test waveforms

9.4 SR Driver on-time

ICE2HS01G SR on-time can be adjusted to match the primary side on-time and current for better efficiency.

9.4.1 Full load

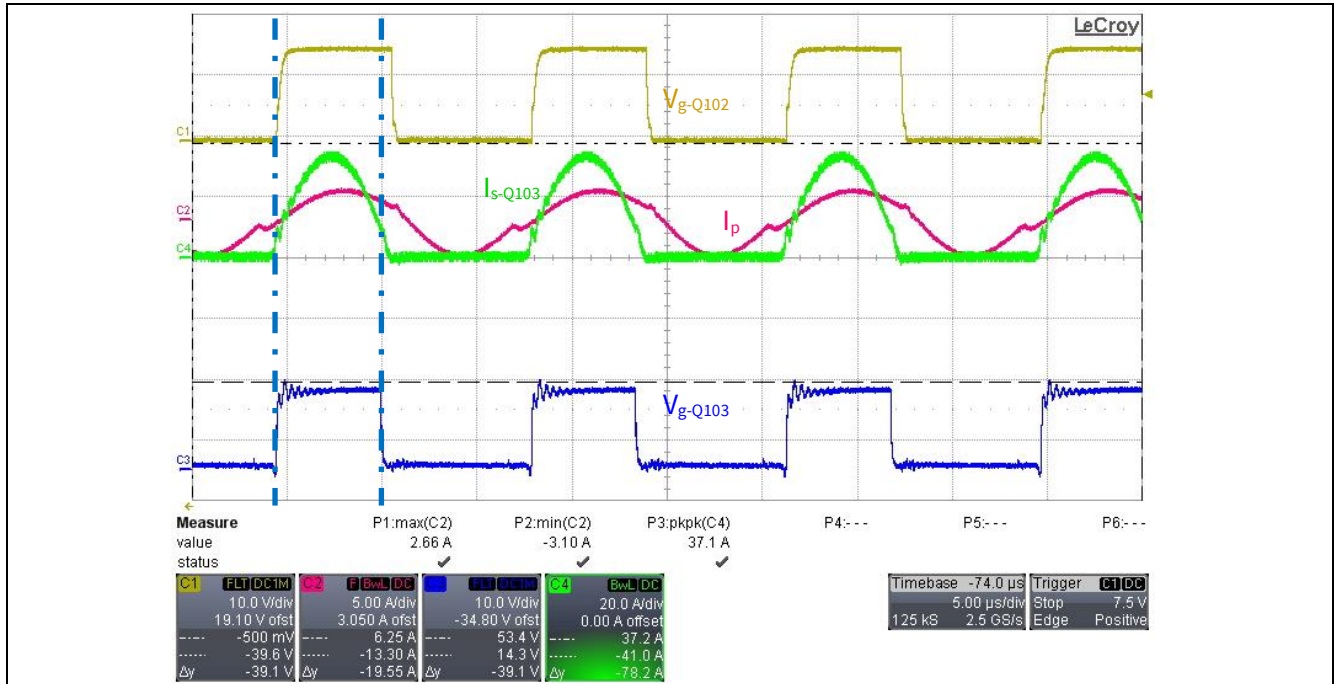

Figure 18 SR Driver on-time at Full load

9.4.2 Light Load (Load = 1 A)

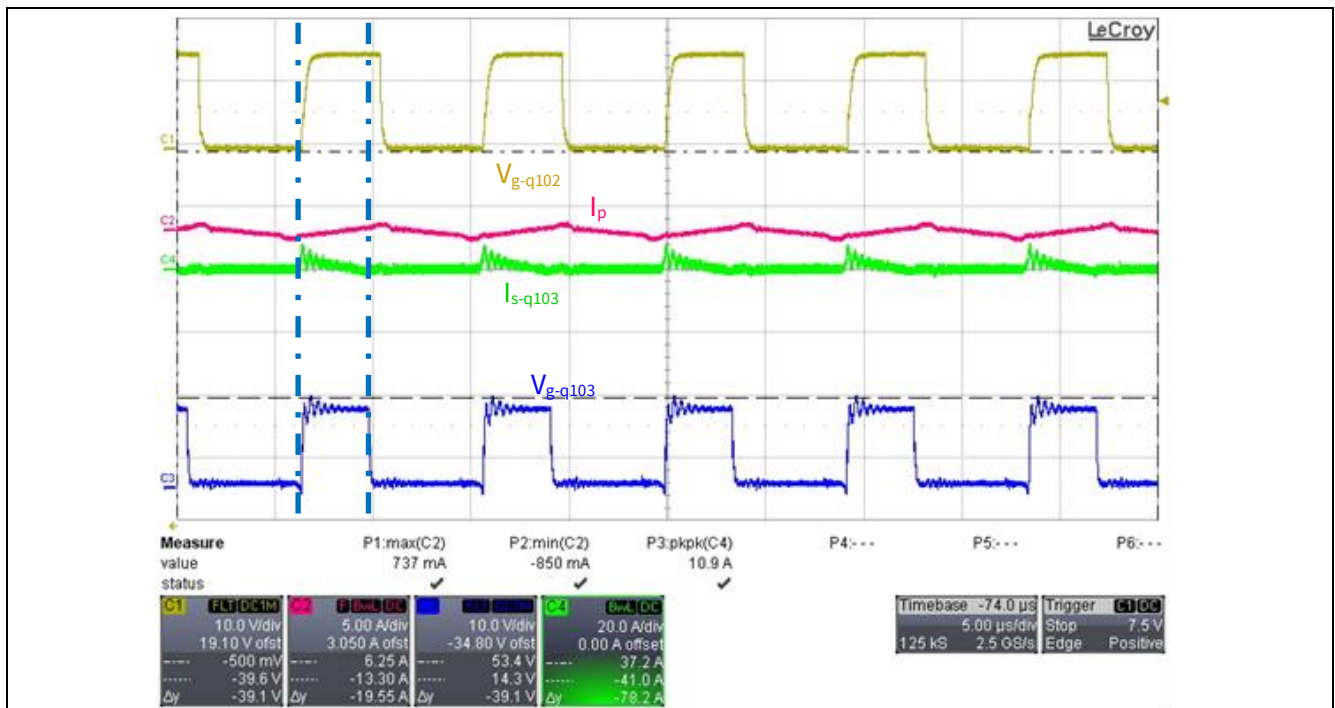

Figure 19 SR Driver on-time at light load

Test waveforms

### 9.5 Zero Voltage Switching

With proper design of the LLC converter, ZVS can be realized over the entire load range. In figure 20, Channel 1 shows the resonant current flowing through the resonant capacitor. Channels 2 and 4 represent the gate-source voltage and drain-source voltage of Q102.

#### 9.5.1 Full load

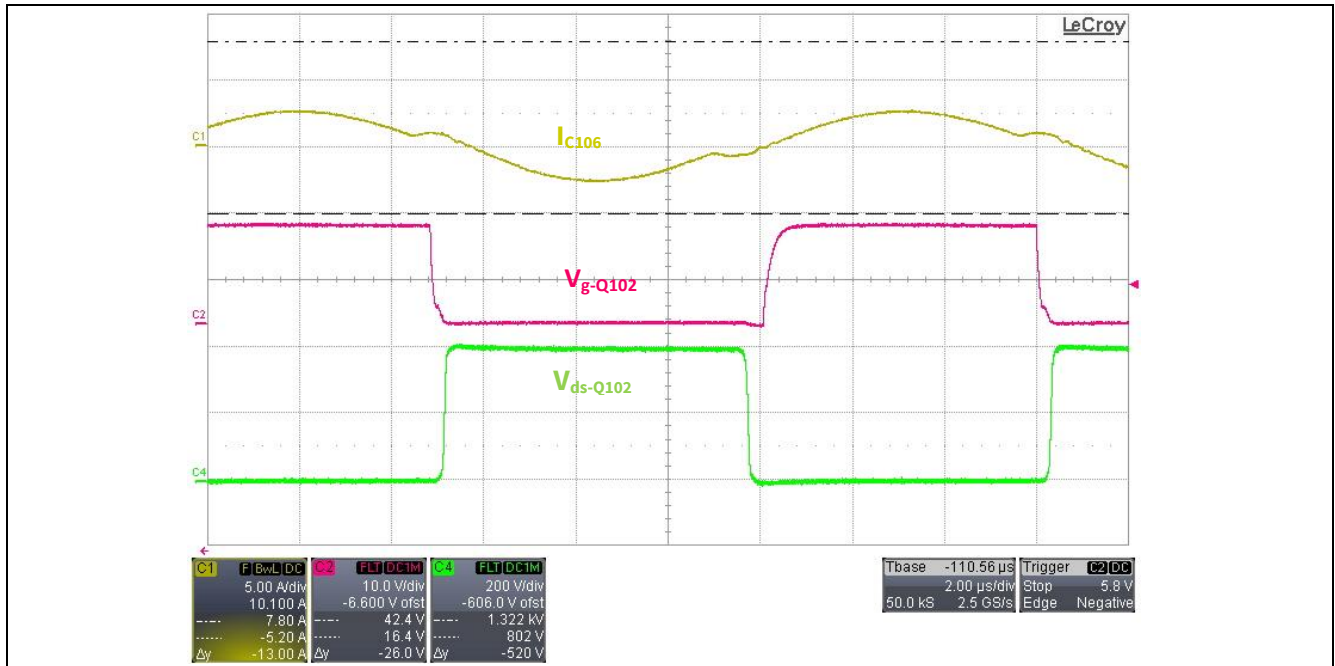

Figure 20 Zero voltage switching at full load

#### 9.5.2 Light load (Load = 1 A)

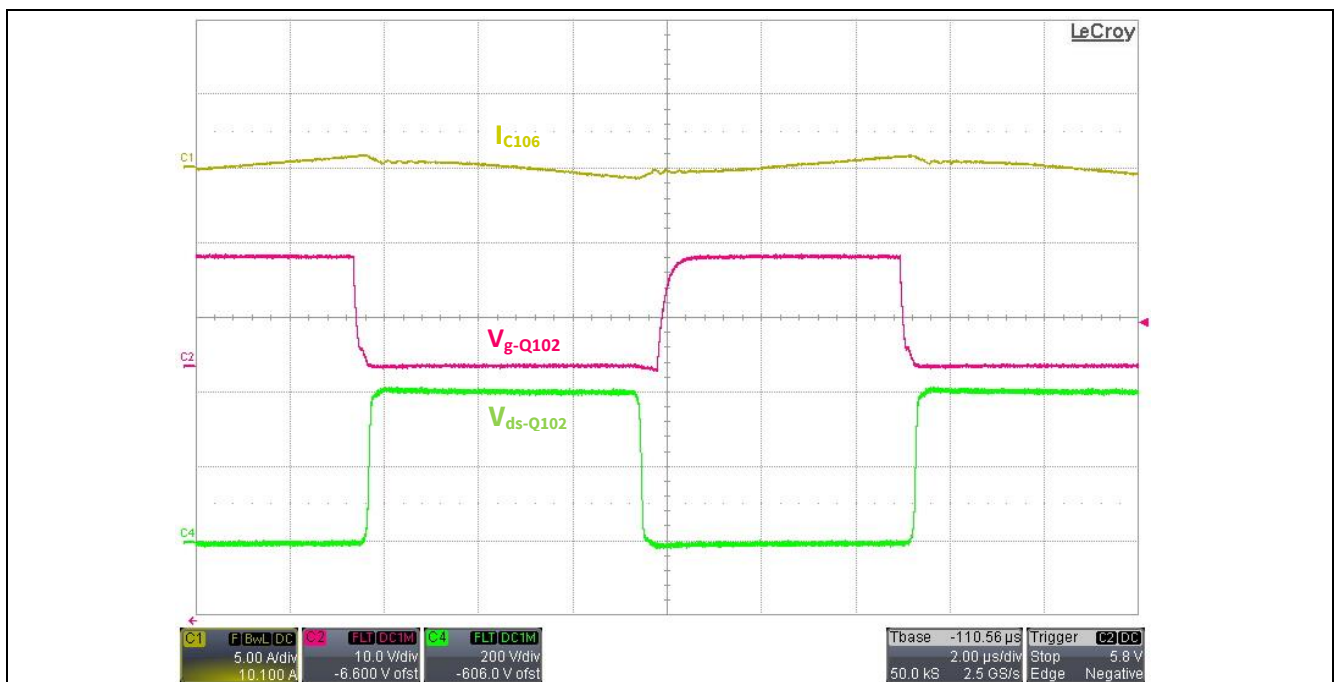

Figure 21 Zero voltage switching at full load

Test waveforms

9.6 Main under voltage protection

IC starts operation when  $V_{bus}$  resumes to normal value  $V_{bus-on} = 368 V_{DC}$ .

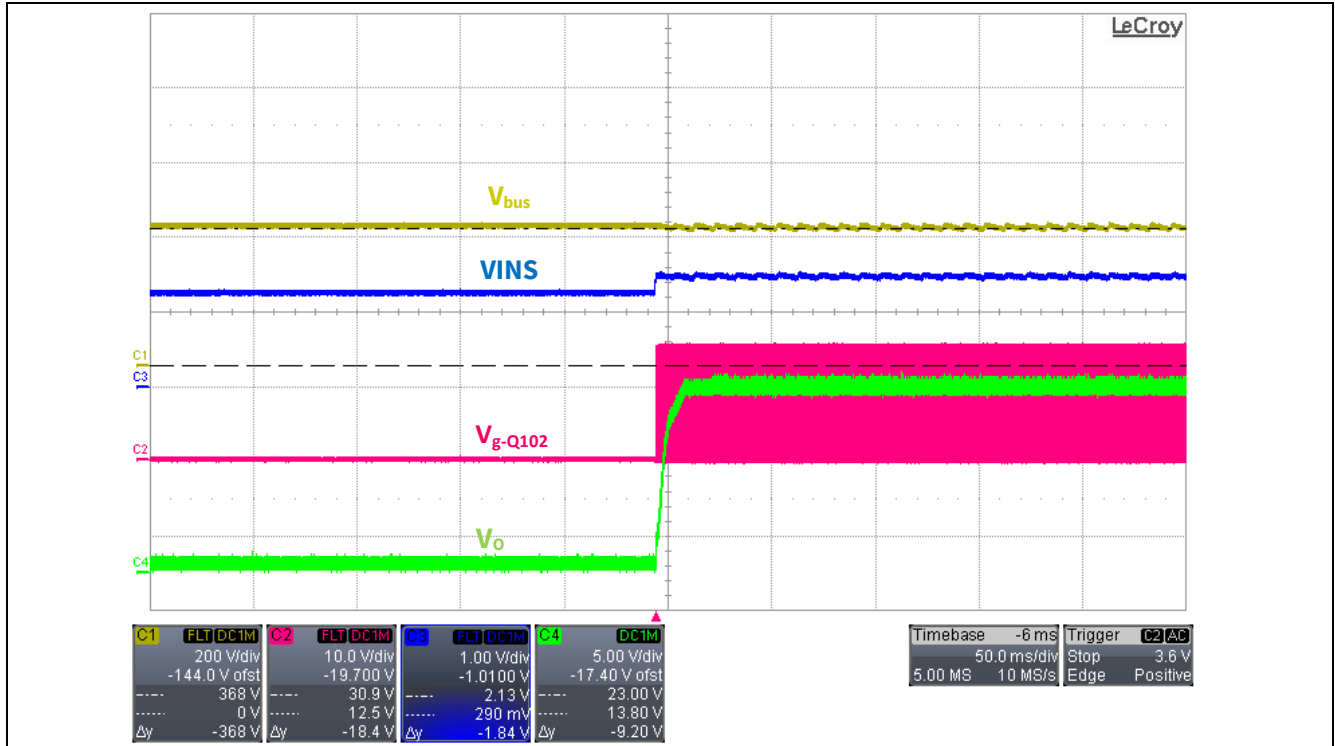

Figure 22 IC starts operation when  $V_{bus}$  resumes to normal value  $V_{bus-on} = 368 V_{DC}$

IC stops switching when  $V_{bus}$  drops to designed value  $V_{bus-off} = 314 V$ .

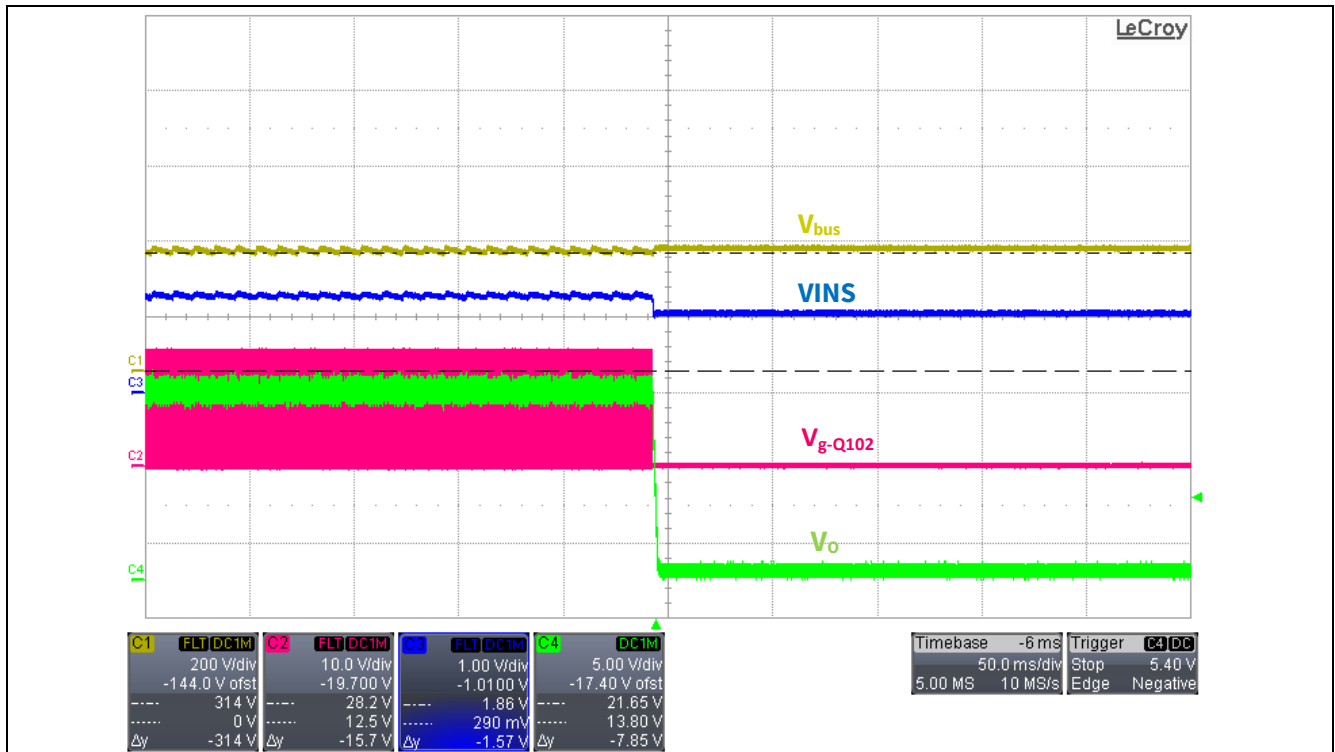

Figure 23 IC stop switching when  $V_{bus}$  drops to designed value  $V_{bus-off} = 314 V$

Test waveforms

9.7 Dynamic load response

9.7.1 12 V @ 2.5 A ~ 20 A, 5 kHz, 800 mA/μs

The output voltage ripple is around 0.8 V.

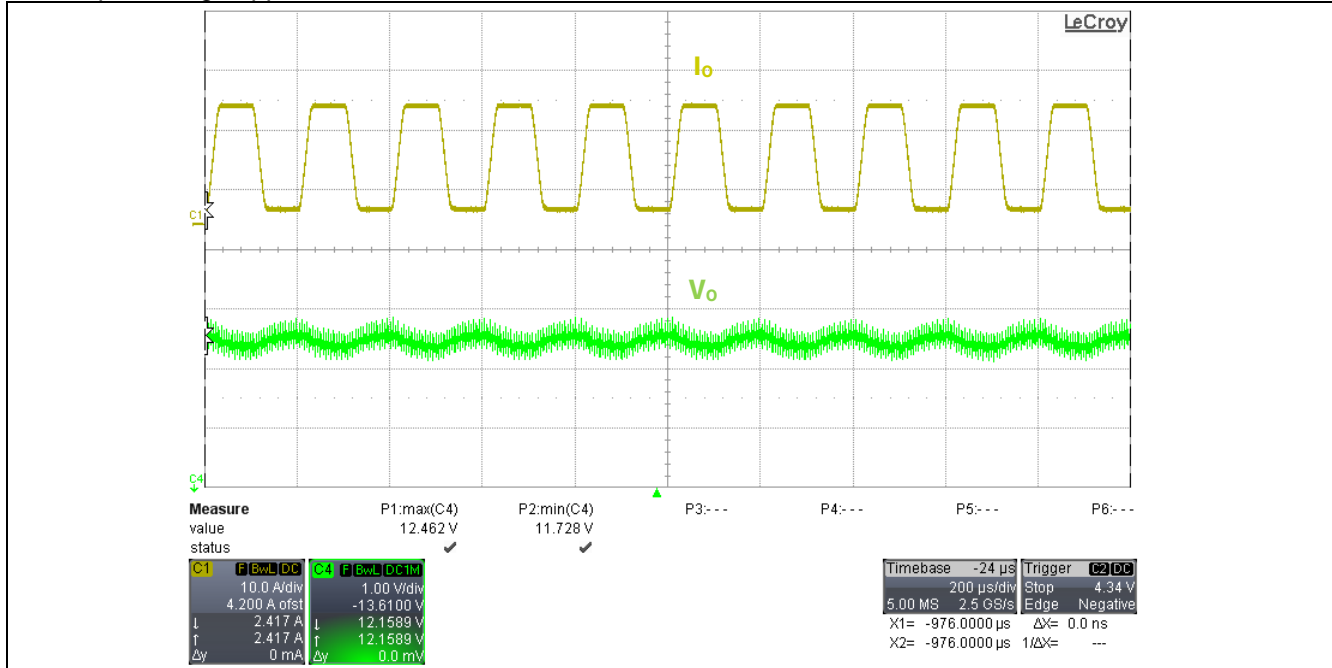

Figure 24 Dynamic load - 12 V @ 2.5 A ~ 20 A, 5 kHz, 800 mA/μs

9.7.2 12 V @ 2.5 A ~ 20 A, 100 Hz, 800m A/μs

The output voltage ripple is around 0.8 V.

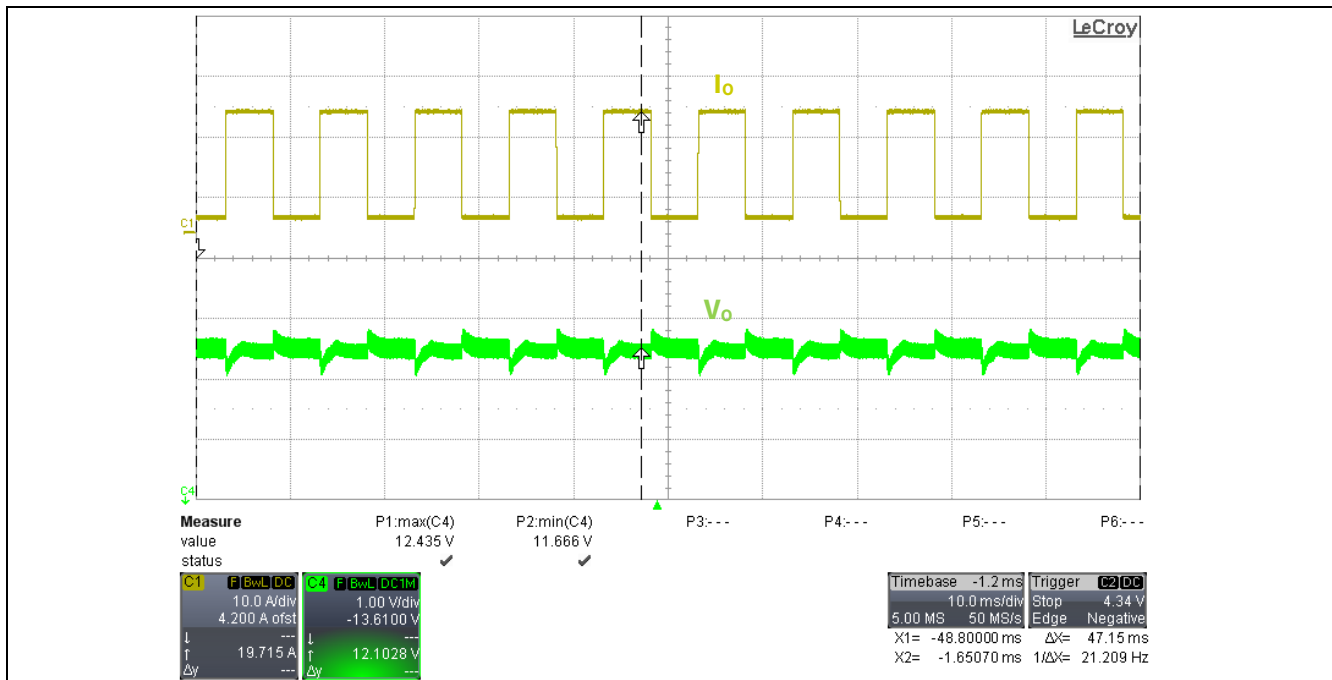

Figure 25 Dynamic load - 12 V @ 2.5 A ~ 20 A, 100 Hz, 800m A/μs

Test waveforms

### 9.8 Hold up time test

The hold up time is approximately 23 ms at full load after the input is disconnected from the board.

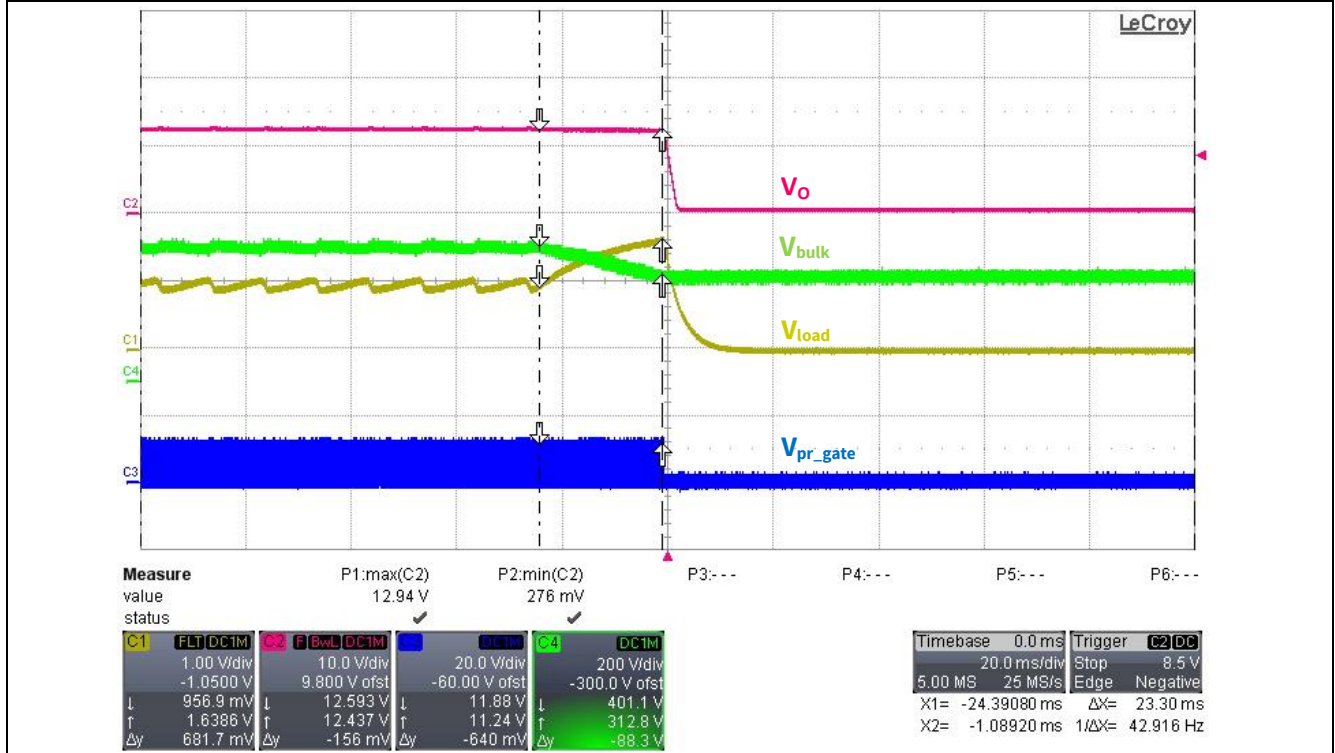

Figure 26 Hold up time

---

References

## 10 References

- [1] [Datasheet ICE2HS01G](#) Half-Bridge Resonant Controller, Infineon Technologies AG, 2011
- [2] [Datasheet IPP60R190E6](#) 600V CoolMOS™ E6 Power Transistor, Infineon Technologies AG, 2014
- [3] [Datasheet IPB011N04N G](#) OptiMOS™3 Power-Transistor, Infineon Technologies AG, 2010
- [4] [Datasheet 2EDL05106BF](#) EiceDRIVER™ Compact 600V half bridge gate drive IC
- [5] [Design Guide for LLC Converter with ICE2HS01G](#), Infineon Technologies AG, 2011

## Revision History

### Major changes since the last revision

Page or Reference	Description of change
	1 <sup>st</sup> release



#### Trademarks of Infineon Technologies AG

AURIX™, C166™, CanPAK™, CIPOS™, CIPURSE™, CoolMOS™, CoolSET™, CORECONTROL™, CROSSAVE™, DAVE™, DI-POL™, EasyPIM™, EconoBRIDGE™, EconoDUAL™, EconoPIM™, EconoPACK™, EiceDRIVER™, eupec™, FCOS™, HITFET™, HybridPACK™, I<sup>2</sup>RF™, ISOFACE™, IsoPACK™, MIPAQ™, ModSTACK™, my-d™, NovalithIC™, OptiMOS™, ORIGA™, POWERCODE™, PRIMARION™, PrimePACK™, PrimeSTACK™, PRO-SIL™, PROFET™, RASIC™, ReverSave™, SatRIC™, SIEGET™, SINDRION™, SIPMOS™, SmartLEWIS™, SOLID FLASH™, TEMPFET™, thinQ!™, TRENCHSTOP™, TriCore™.

#### Other Trademarks

Advance Design System™ (ADS) of Agilent Technologies, AMBA™, ARM™, MULTI-ICE™, KEIL™, PRIMECELL™, REALVIEW™, THUMB™, μVision™ of ARM Limited, UK. AUTOSAR™ is licensed by AUTOSAR development partnership. Bluetooth™ of Bluetooth SIG Inc. CAT-ig™ of DECT Forum. COLOSSUS™, FirstGPS™ of Trimble Navigation Ltd. EMV™ of EMVCo, LLC (Visa Holdings Inc.). EPCOS™ of Epcos AG. FLEXGO™ of Microsoft Corporation. FlexRay™ is licensed by FlexRay Consortium. HYPERTERMINAL™ of Hilgraeve Incorporated. IEC™ of Commission Electrotechnique Internationale. IrDA™ of Infrared Data Association Corporation. ISO™ of INTERNATIONAL ORGANIZATION FOR STANDARDIZATION. MATLAB™ of MathWorks, Inc. MAXIM™ of Maxim Integrated Products, Inc. MICROTEC™, NUCLEUS™ of Mentor Graphics Corporation. MIPI™ of MIPI Alliance, Inc. MIPS™ of MIPS Technologies, Inc., USA. muRata™ of MURATA MANUFACTURING CO., MICROWAVE OFFICE™ (MWO) of Applied Wave Research Inc., OmniVision™ of OmniVision Technologies, Inc. Openwave™ Openwave Systems Inc. RED HAT™ Red Hat, Inc. RFMD™ RF Micro Devices, Inc. SIRIUS™ of Sirius Satellite Radio Inc. SOLARIS™ of Sun Microsystems, Inc. SPANSION™ of Spansion LLC Ltd. Symbian™ of Symbian Software Limited. TAIYO YUDEN™ of Taiyo Yuden Co. TEAKLITE™ of CEVA, Inc. TEKTRONIX™ of Tektronix Inc. TOKO™ of TOKO KABUSHIKI KAISHA TA. UNIX™ of X/Open Company Limited. VERILOG™, PALLADIUM™ of Cadence Design Systems, Inc. VLYNQ™ of Texas Instruments Incorporated. VXWORKS™, WIND RIVER™ of WIND RIVER SYSTEMS, INC. ZETEX™ of Diodes Zetex Limited.  
Last Trademarks Update 2011-11-11

[www.infineon.com](http://www.infineon.com)

**Edition 2015-10-30**

**Published by**

**Infineon Technologies AG**

**81726 Munich, Germany**

**© 2015 Infineon Technologies AG.**

**All Rights Reserved.**

**Do you have a question about any aspect of this document?**

**Email: [erratum@infineon.com](mailto:erratum@infineon.com)**

**Document reference**

**ANDEMO\_201510\_PL21\_009**

#### Legal Disclaimer

THE INFORMATION GIVEN IN THIS APPLICATION NOTE (INCLUDING BUT NOT LIMITED TO CONTENTS OF REFERENCED WEBSITES) IS GIVEN AS A HINT FOR THE IMPLEMENTATION OF THE INFINEON TECHNOLOGIES COMPONENT ONLY AND SHALL NOT BE REGARDED AS ANY DESCRIPTION OR WARRANTY OF A CERTAIN FUNCTIONALITY, CONDITION OR QUALITY OF THE INFINEON TECHNOLOGIES COMPONENT. THE RECIPIENT OF THIS APPLICATION NOTE MUST VERIFY ANY FUNCTION DESCRIBED HEREIN IN THE REAL APPLICATION. INFINEON TECHNOLOGIES HEREBY DISCLAIMS ANY AND ALL WARRANTIES AND LIABILITIES OF ANY KIND (INCLUDING WITHOUT LIMITATION WARRANTIES OF NON-INFRINGEMENT OF INTELLECTUAL PROPERTY RIGHTS OF ANY THIRD PARTY) WITH RESPECT TO ANY AND ALL INFORMATION GIVEN IN THIS APPLICATION NOTE.

#### Information

For further information on technology, delivery terms and conditions and prices, please contact the nearest Infineon Technologies Office ([www.infineon.com](http://www.infineon.com)).

#### Warnings

Due to technical requirements, components may contain dangerous substances. For information on the types in question, please contact the nearest Infineon Technologies Office. Infineon Technologies components may be used in life-support devices or systems only with the express written approval of Infineon Technologies, if a failure of such components can reasonably be expected to cause the failure of that life-support device or system or to affect the safety or effectiveness of that device or system. Life support devices or systems are intended to be implanted in the human body or to support and/or maintain and sustain and/or protect human life. If they fail, it is reasonable to assume that the health of the user or other persons may be endangered.



Компания «ЭлектроПласт» предлагает заключение долгосрочных отношений при поставках импортных электронных компонентов на взаимовыгодных условиях!

Наши преимущества:

- Оперативные поставки широкого спектра электронных компонентов отечественного и импортного производства напрямую от производителей и с крупнейших мировых складов;
- Поставка более 17-ти миллионов наименований электронных компонентов;
- Поставка сложных, дефицитных, либо снятых с производства позиций;
- Оперативные сроки поставки под заказ (от 5 рабочих дней);
- Экспресс доставка в любую точку России;
- Техническая поддержка проекта, помощь в подборе аналогов, поставка прототипов;
- Система менеджмента качества сертифицирована по Международному стандарту ISO 9001;
- Лицензия ФСБ на осуществление работ с использованием сведений, составляющих государственную тайну;
- Поставка специализированных компонентов (Xilinx, Altera, Analog Devices, Intersil, Interpoint, Microsemi, Aeroflex, Peregrine, Syfer, Eurofarad, Texas Instrument, Miteq, Cobham, E2V, MA-COM, Hittite, Mini-Circuits, General Dynamics и др.);

Помимо этого, одним из направлений компании «ЭлектроПласт» является направление «Источники питания». Мы предлагаем Вам помощь Конструкторского отдела:

- Подбор оптимального решения, техническое обоснование при выборе компонента;
- Подбор аналогов;
- Консультации по применению компонента;
- Поставка образцов и прототипов;
- Техническая поддержка проекта;
- Защита от снятия компонента с производства.



#### Как с нами связаться

**Телефон:** 8 (812) 309 58 32 (многоканальный)

**Факс:** 8 (812) 320-02-42

**Электронная почта:** [org@eplast1.ru](mailto:org@eplast1.ru)

**Адрес:** 198099, г. Санкт-Петербург, ул. Калинина, дом 2, корпус 4, литера А.