

BS-21740-000
SHT 1.1

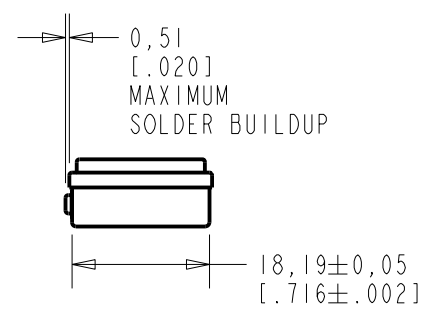
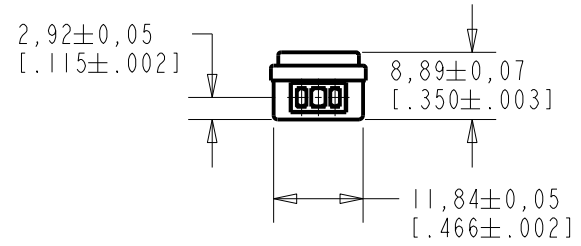
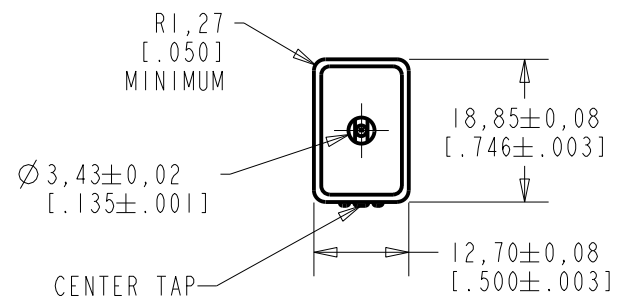

SCALE 1:1
NOMINAL WEIGHT
5.1 GRAMS
DIMENSIONS IN MILLIMETERS [INCHES]

Revision	C.O. #	Implementation Date	RELEASE LEVEL	REVISION
C	MI0104194	6-24-11	Active	C
B	MI0102962	7-30-09		
A	MI0101091	5-16-06		

SCALE: 1:1		DR. BY MMM	DATE 5-16-06
DO NOT SCALE DRAWING			
TITLE: BEEPER - SPEAKER		GJP 6-6-06	
BS-21740-000		APP. BY GJP	
OUTLINE DRAWING		DATE 6-6-06	
SHT 1.1		Rev: B	

KNOWLES ELECTRONICS
ITASCA, ILLINOIS U.S.A.

BEEPER-SPEAKER RESPONSE:

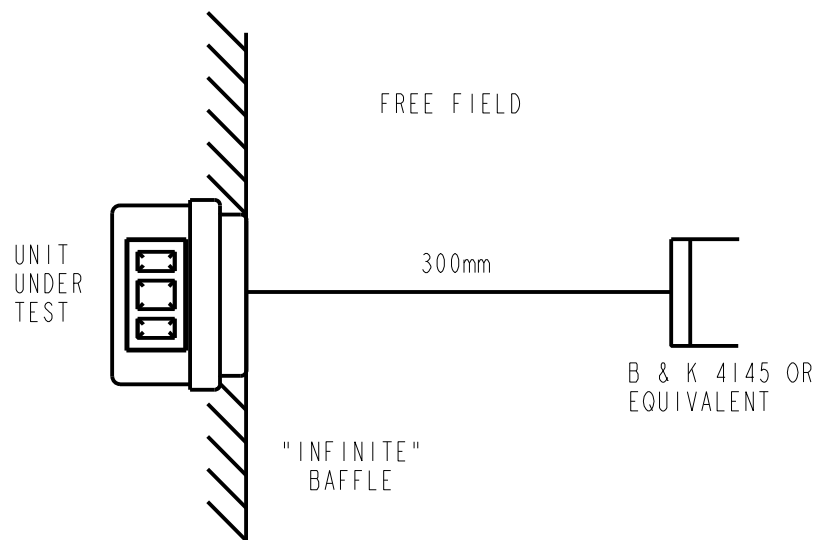

FIG. 1

NOTES:

1. SENSITIVITY IN dB RELATIVE TO .0002 MICROBAR ($2 \times 10^{-5} \text{ N/m}^2$) FOR THE CONDITIONS SHOWN IN "2 & 3" BELOW.
2. MEASUREMENTS MADE WITH UNIT MOUNTED FLUSH IN AN "INFINITE" BAFFLE FACING A FREE FIELD. A B & K 1" FREE FIELD MICROPHONE MOUNTED AT NORMAL INCIDENCE AT A DISTANCE 300mm FROM THE BAFFLE IS USED TO MONITOR THE SOUND PRESSURE. SEE FIG 1.
3. ELECTRICAL SIGNAL (ACROSS WINDINGS IN SERIES):
SOURCE RESISTANCE: <1 OHM
DC CURRENT: 0.0 mA
SIGNAL: 5.2 VOLTS PEAK-TO-PEAK SQUARE WAVE
4. NOMINAL IMPEDANCE (WINDINGS IN SERIES): 340 OHMS AT 1kHz
5. NOMINAL DC RESISTANCE (WINDINGS IN SERIES): 67 OHMS
6. SENSITIVITY:
85 dB MINIMUM AT SOME FREQUENCY BETWEEN 1800 AND 2200 Hz
83 dB MINIMUM AT SOME FREQUENCY BETWEEN 2800 AND 3200 Hz

NOTE: THE PEAKS OF OUTPUT MAY LIE JUST OUTSIDE THE FERQUENCY LIMITS.

Revision	C.O. #	Implementation Date	RELEASE LEVEL	REVISION
C	M10104194	6-24-11	Active	C
B	M10102962	7-30-09		
A	M10101091	5-16-06		
WHEN TEST LIMITS ARE USED TO ESTABLISH INCOMING INSPECTION ACCEPTANCE/REJECTION CRITERIA, CORRELATION OF TEST EQUIPMENT WITH KNOWLES IS ALSO REQUIRED FOR ELIMINATION OF EQUIPMENT AND TEST METHOD VARIATION			DR. BY	DATE
TITLE: BEEPER-SPEAKER PERFORMANCE SPECIFICATION			MMM	5-16-06
			BS-21740-000	
SHT 2.1			CK. BY	DATE
			GJP	6-6-06
			APP. BY	DATE
			GJP	6-6-06

KNOWLES ELECTRONICS
ITASCA, ILLINOIS U.S.A.

SENSITIVITY IN dB RELATIVE TO 1.0 VOLT/0.1 Pa (N/m²)
FOR CONDITIONS SHOWN BELOW.

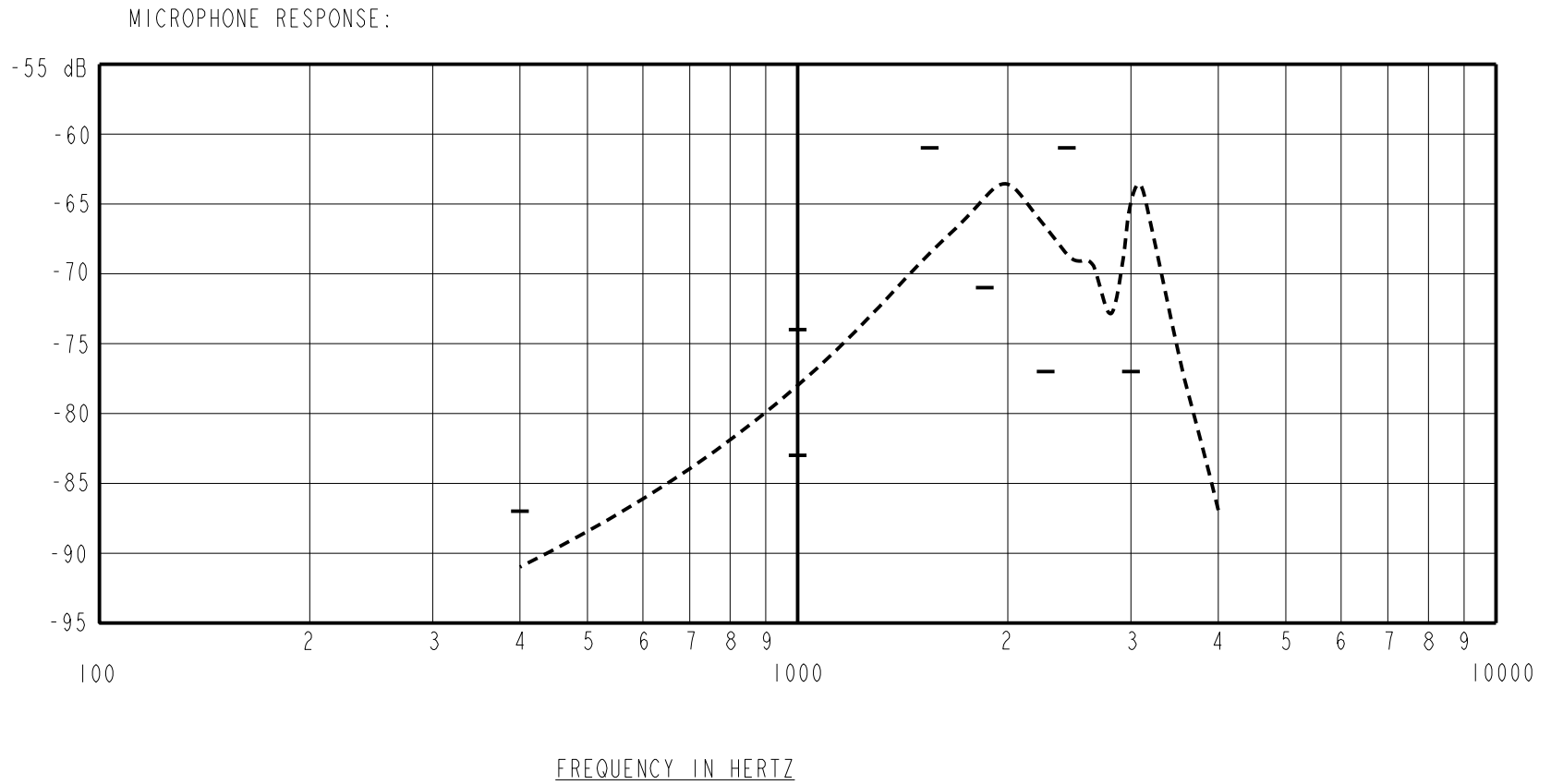

SENSITIVITY				DEVICE CONFORMITY	
FREQUENCY	MIN.	NOM.	MAX.	RANGE OF DEVIATION FROM 1KHZ	
400	---	-91	---	-17	-9
1000	-83	-78	-74	0.0	0.0
1500	---	---	---	---	17
1800	---	---	---	7	---
2200	---	---	---	1	---
2500	---	---	---	---	17
3000	---	---	---	1	---

NOTES:

1. MEASUREMENTS MADE WITH 1000Ω RESISTANCE LOAD, AND 10 μBAR FIELD.
2. OUTPUT MEASURED BETWEEN OUTER TERMINAL PADS.

Revision	C.O. #	Implementation Date	RELEASE LEVEL	REVISION
C	M10104194	6-24-11	Active	C
B	M10102962	7-30-09		
A	M10101091	5-16-06		

WHEN TEST LIMITS ARE USED TO ESTABLISH INCOMING INSPECTION ACCEPTANCE/REJECTION CRITERIA, CORRELATION OF TEST EQUIPMENT WITH KNOWLES IS ALSO REQUIRED FOR ELIMINATION OF EQUIPMENT AND TEST METHOD VARIATION		DR. BY	DATE
		MMM	5-16-06
TITLE: BEEPER-SPEAKER PERFORMANCE SPECIFICATION		CK. BY	DATE
		GJP	6-6-06
BS-21740-000 SHT 2.2		APP. BY	DATE
		GJP	6-6-06

KNOWLES ELECTRONICS
ITASCA, ILLINOIS U.S.A.



Компания «ЭлектроПласт» предлагает заключение долгосрочных отношений при поставках импортных электронных компонентов на взаимовыгодных условиях!

Наши преимущества:

- Оперативные поставки широкого спектра электронных компонентов отечественного и импортного производства напрямую от производителей и с крупнейших мировых складов;
- Поставка более 17-ти миллионов наименований электронных компонентов;
- Поставка сложных, дефицитных, либо снятых с производства позиций;
- Оперативные сроки поставки под заказ (от 5 рабочих дней);
- Экспресс доставка в любую точку России;
- Техническая поддержка проекта, помощь в подборе аналогов, поставка прототипов;
- Система менеджмента качества сертифицирована по Международному стандарту ISO 9001;
- Лицензия ФСБ на осуществление работ с использованием сведений, составляющих государственную тайну;
- Поставка специализированных компонентов (Xilinx, Altera, Analog Devices, Intersil, Interpoint, Microsemi, Aeroflex, Peregrine, Syfer, Eurofarad, Texas Instrument, Miteq, Cobham, E2V, MA-COM, Hittite, Mini-Circuits, General Dynamics и др.);

Помимо этого, одним из направлений компании «ЭлектроПласт» является направление «Источники питания». Мы предлагаем Вам помощь Конструкторского отдела:

- Подбор оптимального решения, техническое обоснование при выборе компонента;
- Подбор аналогов;
- Консультации по применению компонента;
- Поставка образцов и прототипов;
- Техническая поддержка проекта;
- Защита от снятия компонента с производства.



Как с нами связаться

Телефон: 8 (812) 309 58 32 (многоканальный)

Факс: 8 (812) 320-02-42

Электронная почта: org@eplast1.ru

Адрес: 198099, г. Санкт-Петербург, ул. Калинина, дом 2, корпус 4, литера А.