

NOTES:

1. MATERIALS AND FINISHES:
 BODY & CONTACT - BRASS, GOLD PLATING
 INSULATOR - LCP E130i
2. ELECTRICAL:
 A. IMPEDANCE: 50 OHM
 B. RETURN LOSS: 1.10 MAX. (-26.4 dB MIN.), @ DC-6 GHz
 1.15 MAX. (-23.1 dB MIN.), @ 6-10 GHz
 1.30 MAX. (-17.7 dB MIN.), @ 10-18 GHz
 CONNECTOR ONLY, PERFORMANCE WILL VARY
 BASED ON BOARD LAYOUT
 C. INSERTION LOSS: 0.05* SQRT(f) dB MAX ; "f" IN GHz
 D. DIELECTRIC WITHSTANDING VOLTAGE: 500 VRMS, MIN.
3. MECHANICAL:
 A. DURABILITY: 500 CYCLES MIN.
 B. ENGAGEMENT FORCE: 10 LBS (45 N) MAX.
 C. DISENGAGEMENT FORCE: 2 LBS (9 N) MIN.
 D. INNER CONTACT RETENTION FORCE: 1.5 LBS (7 N) MIN.
 E. TEMPERATURE RANGE: -65°C TO +165°C
4. PACKAGING
 A. QUANTITY: TAPE & REEL PACKAGING, 600 PCS/REEL
 B. MARKING: REEL TO BE MARKED:
 " AMPHENOL RF, SMP-MSLD-PCT15T AND DATE CODE"

THIRD ANGLE PROJ.

REVISIONS

REV	DESCRIPTION	DATE	ECO	APPR
A	RELEASE TO MFG	07-Jun-18	08221	BMG

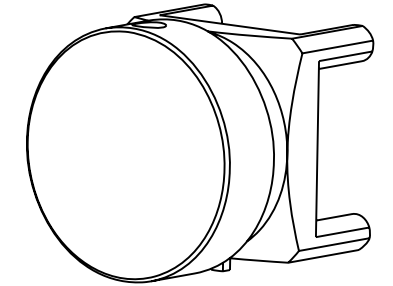

SCALE 5.000

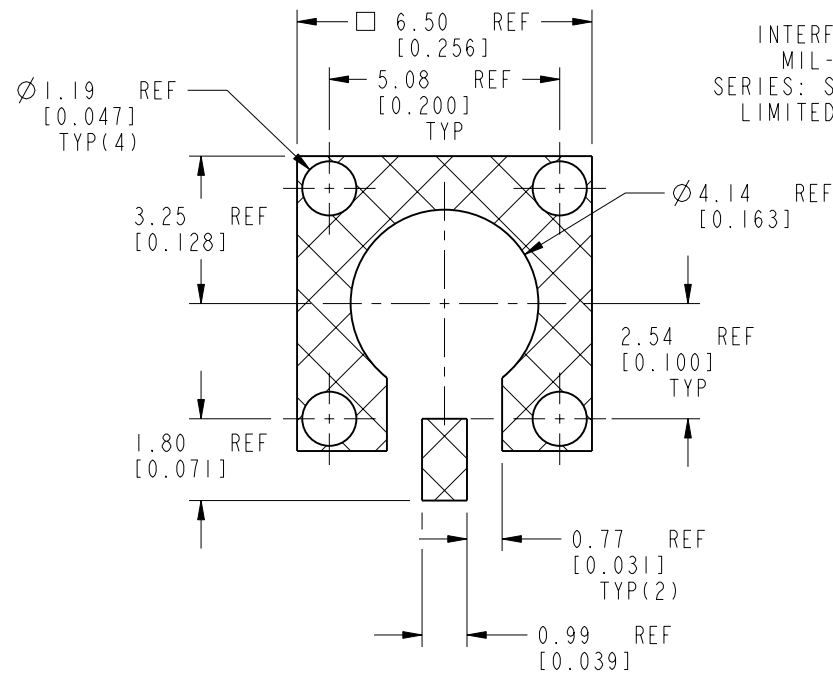

INTERFACE PER MIL-STD-348 SERIES: SMP JACK LIMITED DETENT

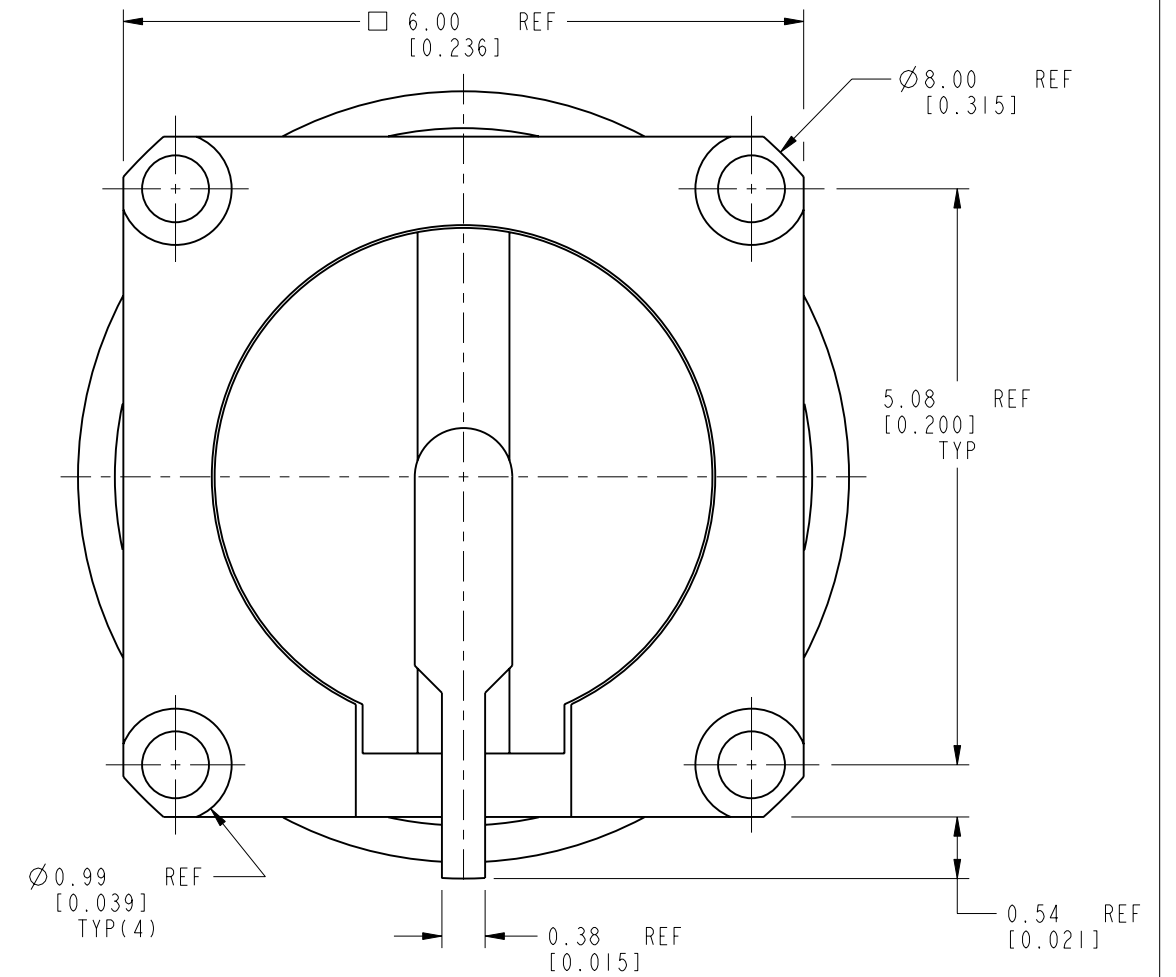
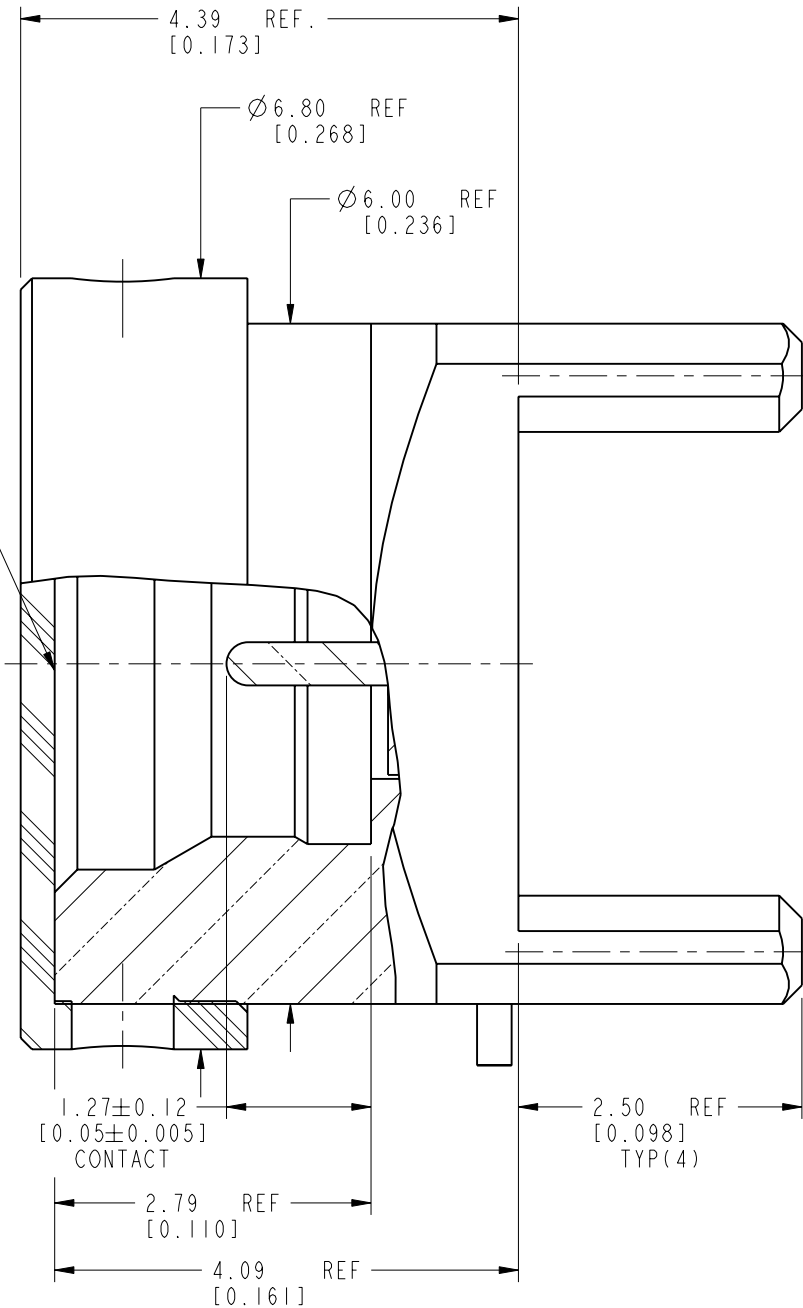

CUSTOMER OUTLINE DRAWING

ALL OTHER SHEETS ARE FOR INTERNAL USE ONLY

UNLESS OTHERWISE SPECIFIED, DIMENSIONS ARE IN METRIC AND TOLERANCES ARE:
 <0.5mm ±0.05mm 0.5 - 6mm ±0.1mm 6 - 30mm ±0.2mm 30 - 120mm ±0.3mm ANGLES ±1°

NOTICE - These drawings, specifications, or other data (1) are, and remain the property of Amphenol corp. (2) must be returned upon request; and (3) are confidential and not to be disclosed to any person other than those to whom they are given by Amphenol Corp. the furnishing of these drawings, specifications, or other data by Amphenol Corp., or to any other person to anyone for any purpose is not to be regarded by implication or otherwise in any manner licensing, granting rights to permitting such holder or any other person to manufacture, use or sell any product, process or design, patented or otherwise, that may in any way be related to or disclosed by said drawings, specifications, or other data.

MATERIAL	DRAWN S. DUAN	DATE 07-Jun-18	TITLE SMP STR JACK PCB RECEPTACLE LIMITED DETENT	Amphenol RF www.amphenolrf.com
REFERENCE 8020 AND SMP-MSLD-PCT12T	ENGINEER M. DEFRANCO	DATE 07-Jun-18		
CONFIGURATION LEVEL: In Work	APPROVED S. HSIEH	DATE 20-Jun-18	SCALE: 15.0:1.0 SHEET 2 OF 3	DRAWING NO. SMP-MSLD-PCT15T
FINISH	CAD FILE		DWG SIZE B	REV A
				ITEM NO. SMP-MSLD-PCT15T
				PART NO. SMP-MSLD-PCT15T

REV	DESCRIPTION	DATE	ECO	APPR
A	RELEASE TO MFG	07-Jun-18	08221	BMG

零件图

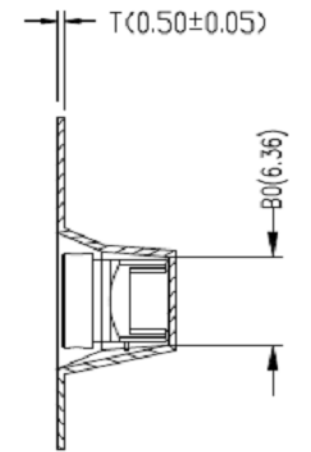
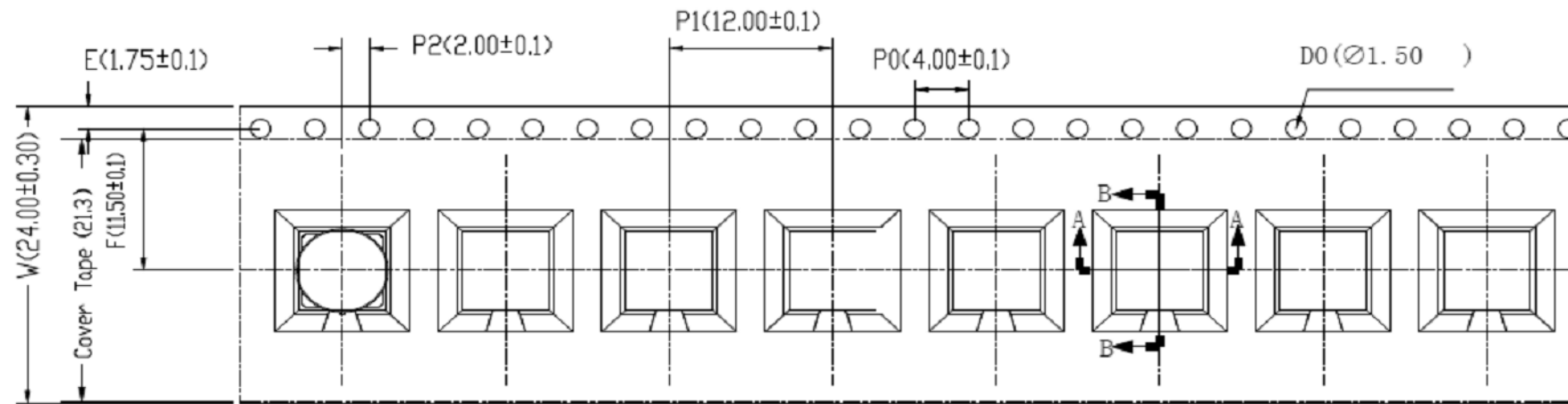

SECTION B-B

载带卷料方向

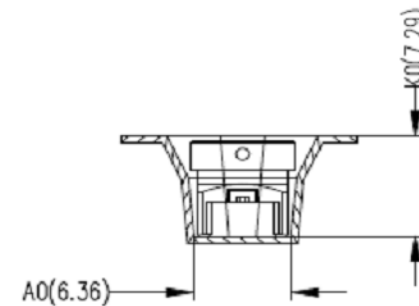

SECTION A-A

Notes:

1. 10 sprocket hole pitch cumulative tolerance $\pm 0.20\text{mm}$
(每10个链轮齿孔径累计公差为 $\pm 0.2\text{MM}$)
2. Carrier camber not to exceed 1mm in 250mm.
(传送料带弯曲变形度每250MM不超过1MM)
3. A_0 and B_0 measured on a plane 0.3mm above the bottom of the pocket. (A_0 与 B_0 在同一平面测量且距口袋底部0.3MM)
4. K_0 measured from a plane on the inside bottom of the pocket to the top surface of the carrier.
(K_0 为口袋底部与材料表面的平面距离。)
5. All dimensions meet EIA-481-D requirements.
(所有尺寸符合EIA-481-D标准要求。)
6. Material: Black Antistatic polystyrene.
(材料: 黑色抗静电聚苯乙烯。)
7. Thickness: $0.50 \pm 0.05 \text{ mm}$.
(厚度: 0.50 ± 0.05 毫米。)
8. Packing length per 13" reel : 8.16Meters.
(每个13"卷轴包装长度为8.16米。)
9. Component loader per 13" reel : 600 pcs.
(每个13"卷轴可装600个零件。)

注:未注公差为 ± 0.10

NOTE: ALL TOLERANCES ARE: ± 0.10 , EXCEPT WHERE NOTED

ITEM	W	A_0	B_0	K_0	K_1	P_1	F	E	D_0	D_1	P_0	P_2	T
DIM	24 ± 0.3	6.36 ± 0.1	6.36 ± 0.1	7.29 ± 0.1		12.0 ± 0.1	11.5 ± 0.1	1.75 ± 0.1	1.5 ± 0.1		4.0 ± 0.1	2.0 ± 0.1	0.5 ± 0.05

UNLESS OTHERWISE SPECIFIED, DIMENSIONS ARE IN METRIC AND TOLERANCES ARE:
 < 0.5mm $\pm 0.05\text{mm}$ 0.5 - 6mm $\pm 0.1\text{mm}$ 6 - 30mm $\pm 0.2\text{mm}$ 30 - 120mm $\pm 0.3\text{mm}$ ANGLES $\pm 1^\circ$

NOTICE - These drawings, specifications, or other data (1) are, and remain the property of Amphenol corp. (2) must be returned upon request; and (3) are confidential and not to be disclosed to any person other than those to whom they are given by Amphenol Corp. the furnishing of these drawings, specifications, or other data by Amphenol Corp., or to any other person to anyone for any purpose is not to be regarded by implication or otherwise in any manner licensing, granting rights to permitting such holder or any other person to manufacture, use or sell any product, process or design, patented or otherwise, that may in any way be related to or disclosed by said drawings, specifications, or other data.

MATERIAL	
REFERENCE	8020 AND SMP-MSLD-PCT12T
CONFIGURATION LEVEL:	In Work
FINISH	

DRAWN	S. DUAN	DATE	07-Jun-18
ENGINEER	M. DEFRANCO	DATE	07-Jun-18
APPROVED	S. HSIEH	DATE	20-Jun-18
CAD FILE			

TITLE	SMP STR JACK PCB RECEPTACLE LIMITED DETENT
SCALE:	19.0:1.0
SHEET	3 OF 3
DWG SIZE	B
REV	A

Amphenol RF	
www.amphenolrf.com	
DRAWING NO. SMP-MSLD-PCT15T	
ITEM NO. SMP-MSLD-PCT15T	
PART NO. SMP-MSLD-PCT15T	



Компания «ЭлектроПласт» предлагает заключение долгосрочных отношений при поставках импортных электронных компонентов на взаимовыгодных условиях!

Наши преимущества:

- Оперативные поставки широкого спектра электронных компонентов отечественного и импортного производства напрямую от производителей и с крупнейших мировых складов;
- Поставка более 17-ти миллионов наименований электронных компонентов;
- Поставка сложных, дефицитных, либо снятых с производства позиций;
- Оперативные сроки поставки под заказ (от 5 рабочих дней);
- Экспресс доставка в любую точку России;
- Техническая поддержка проекта, помощь в подборе аналогов, поставка прототипов;
- Система менеджмента качества сертифицирована по Международному стандарту ISO 9001;
- Лицензия ФСБ на осуществление работ с использованием сведений, составляющих государственную тайну;
- Поставка специализированных компонентов (Xilinx, Altera, Analog Devices, Intersil, Interpoint, Microsemi, Aeroflex, Peregrine, Syfer, Eurofarad, Texas Instrument, Miteq, Cobham, E2V, MA-COM, Hittite, Mini-Circuits, General Dynamics и др.);

Помимо этого, одним из направлений компании «ЭлектроПласт» является направление «Источники питания». Мы предлагаем Вам помощь Конструкторского отдела:

- Подбор оптимального решения, техническое обоснование при выборе компонента;
- Подбор аналогов;
- Консультации по применению компонента;
- Поставка образцов и прототипов;
- Техническая поддержка проекта;
- Защита от снятия компонента с производства.



Как с нами связаться

Телефон: 8 (812) 309 58 32 (многоканальный)

Факс: 8 (812) 320-02-42

Электронная почта: org@eplast1.ru

Адрес: 198099, г. Санкт-Петербург, ул. Калинина, дом 2, корпус 4, литера А.