

PROPER USE GUIDELINES

Cumulative Trauma Disorders can result from the prolonged use of manually powered hand tools. Hand tools are intended for occasional use and low volume applications. A wide selection of powered application equipment for extended-use, production operations is available.

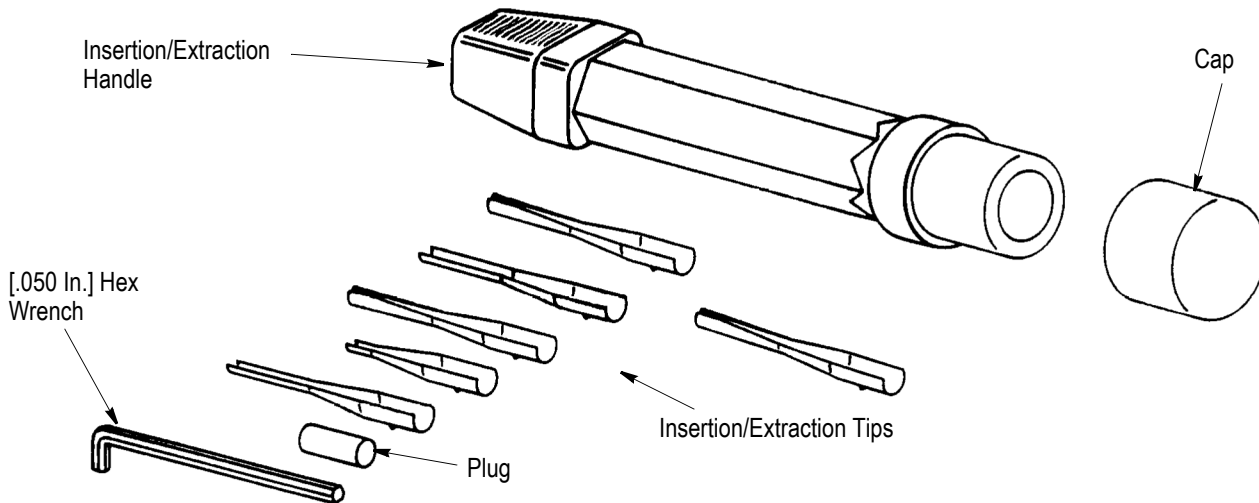

CONTACT SIZE	WIRE SIZE (AWG)	INSERTION/EXTRACTION TIPS		
		COLOR CODE	TYPE	PART NUMBER
HD-20	28-20	Yellow	Insertion	543382-5
HD-20	24-18	Red	Extraction	1-543382-0
HD-20	28-24	Brown	Extraction	1-543382-1
HD-20	Posted	Blue	Extraction	543382-6
HD-20	Posted	Black	Insertion	543382-7
HD-22	28-22	Green	Insertion/Extraction	543382-8

Figure 1

1. INTRODUCTION

This instruction sheet covers the use of Insertion/Extraction Tool 91285-1 and Replacement Tip Kits 543382 shown in Figure 1. The tool is designed to insert and extract HD-22 and HD-20 contacts used in AMPLIMITE* High Density (HD) Connectors.

For information concerning the assembly of AMPLIMITE HD connectors, refer to the instruction sheet packaged with the connector.

Read these instructions thoroughly before using the tool.

See Section 6, REVISION SUMMARY, for revision information.



NOTE
All dimensions on this document are in metric units [with U.S. customary units in brackets]. Figures and

illustrations are for reference only and are not drawn to scale.

2. DESCRIPTION (Figure 1)

The insertion/extraction tool consists of a handle, a cap, six insertion/extraction tips, a plug, and a [.050 in.] hex wrench. The handle of the tool provides storage for the tips, plug, and hex wrench. The insertion/extraction tips convert the tool for the appropriate product and are used to insert or extract connector contacts. Each tip is color coded according to specific type and wire size. The plug is inserted into the widest end of the tip to prevent damage to the tip when it is secured in the tool handle. The hex wrench is used to tighten the setscrew which secures the tip in the tool handle.

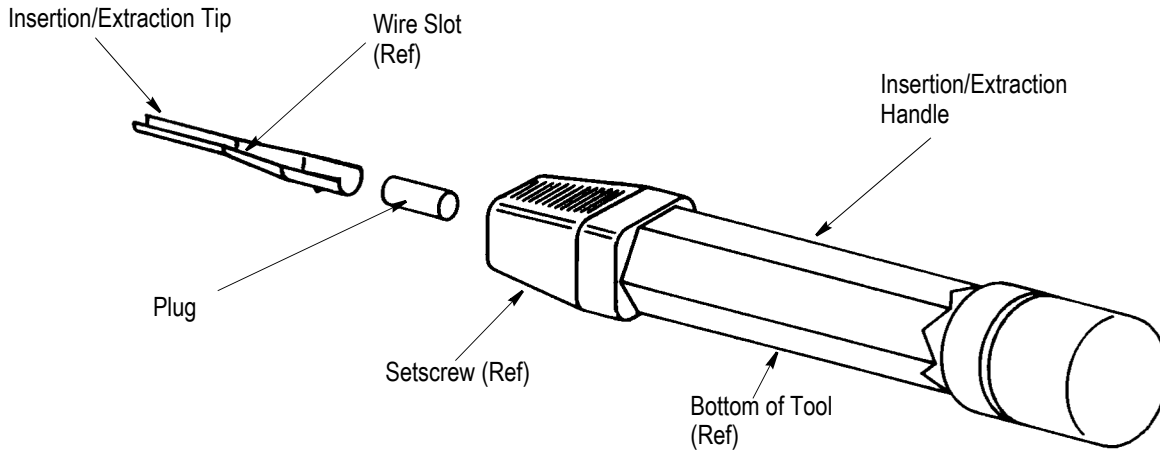

Figure 2

3. TOOL ASSEMBLY (Figure 2)

Refer to Figure 1 and select the appropriate contact, wire size, and insertion/extraction tip. Proceed as follows:

1. Insert plug into the widest end of the insertion/extraction tip.
2. Slide the insertion/extraction tip into the end of the tool handle with the orientation latch positioned toward the bottom of the tool.

3. Using the hex wrench, tighten the setscrew to secure the tip in the tool handle.

4. INSERTION/EXTRACTION PROCEDURES

4.1. Inserting A Wire Crimped Contact (Figure 3)

1. Position tool handle between thumb and fingertips, then place wire over the wire slot of the tip. Hold wire in this position with your thumb.

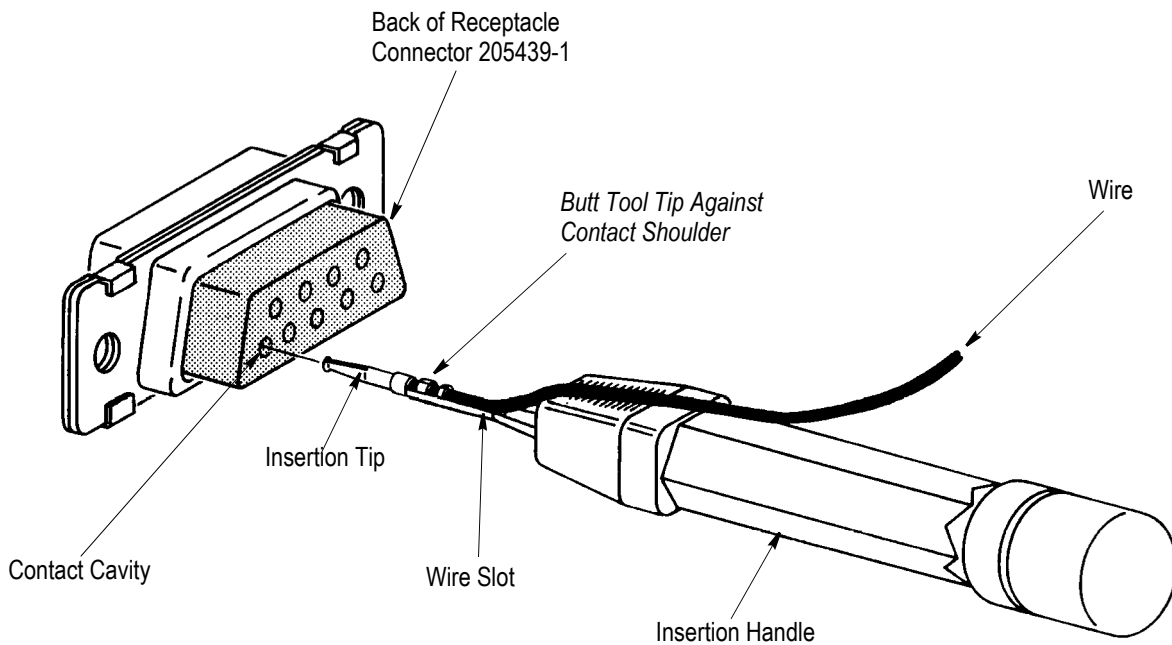

Figure 3

2. Slide thumb over the wire toward the end of the tip.

i **NOTE**
The wire must be positioned inside the wire slot of the tip.

3. Slide tip over contact wire barrel until the tip butts against the contact shoulder.

4. Align contact with the BACK of the contact cavity. Push contact straight into the contact cavity until the contact bottoms.

5. Remove the insertion tool; then pull back on the wire to ensure that the contact is locked into the contact cavity.

4.2. Extracting A Wire Crimped Contact (Figure 4)

1. Position tool handle between thumb and fingertips, and align contact wire with the wire slot on the tip. Hold wire in this position with your thumb.

2. Slide your thumb over the wire toward the end of the insertion tip.

i **NOTE**
The wire must be positioned inside the wire slot of the tip.

3. Place tip over the contact post or crimp barrel and slide the tip straight into the contact cavity until the tip bottoms against the contact shoulder.

4. Holding the wire tight against the tool handle, pull back on the tool handle to extract the contact. If you experience difficulty in extracting the contact, repeat Steps 1 through 4.

4.3. Inserting A Posted Contact (Figure 5)

1. Place the contact in the contact cavity. Do NOT push on the contact post.

2. Position the tip over the contact post. Move the tool along the post until the tip butts against the contact stabilizer. Align the tip on the stabilizer as shown in Figure 5.

3. Hold the tool handle, and push the contact post to make certain that the contact is locked in the cavity.

i **NOTE**
Contacts with tail lengths longer than 10.85 mm [.427 in.] must use yellow color coded insertion tips.

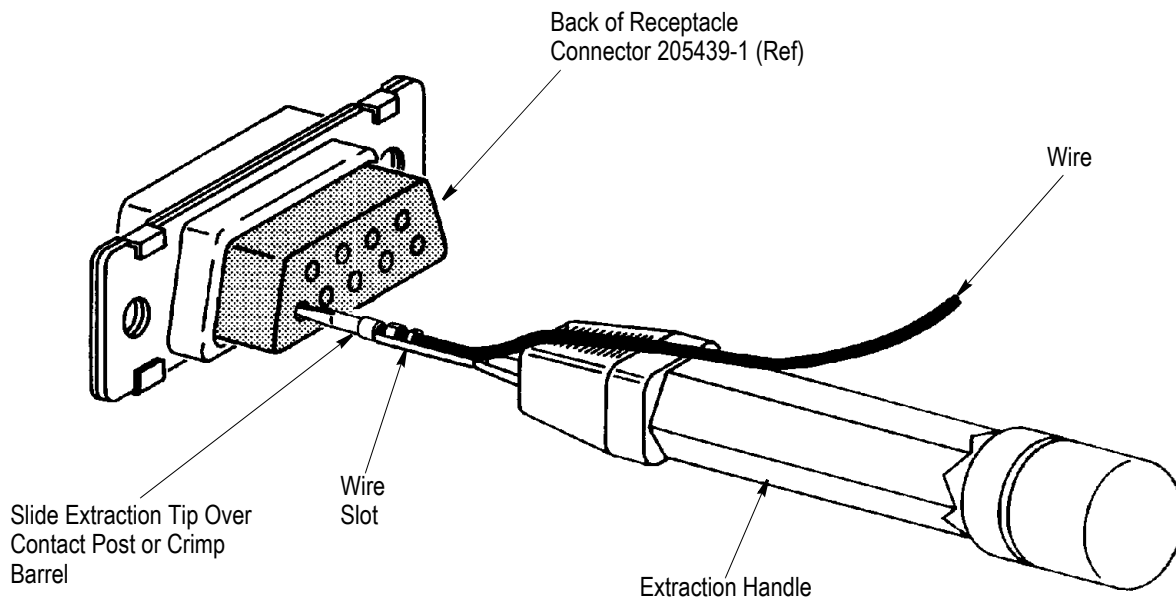

Figure 4

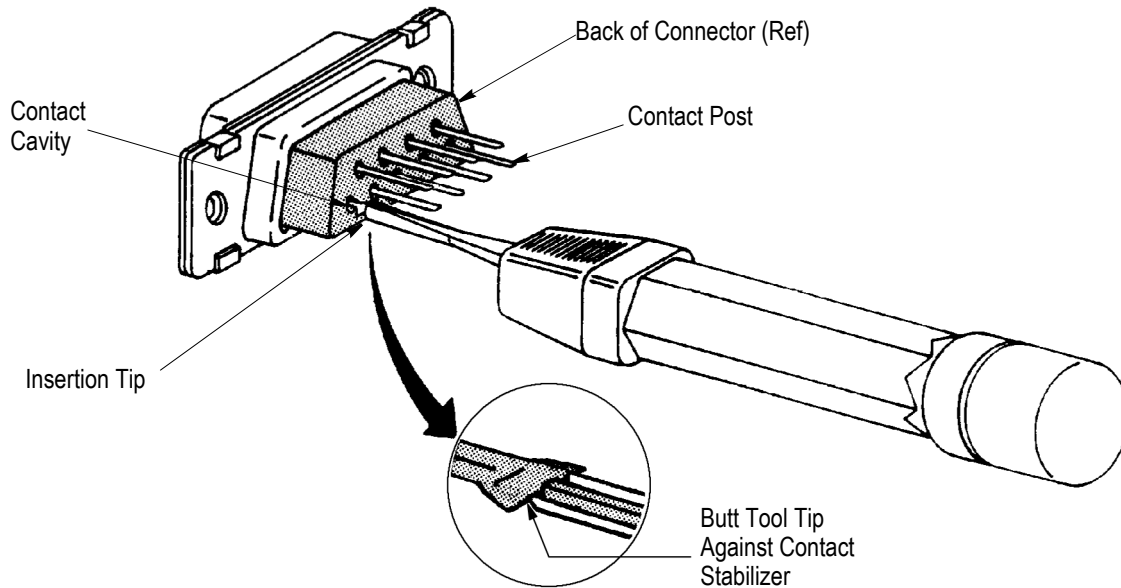

Figure 5

4.4. Extracting A Posted Contact (Figure 6)

1. Place the extraction tip over the contact post. Move the tool along the post until the tip enters the contact cavity.
2. Align the groove of the extraction tip with the contact stabilizer as shown in Figure 6.
3. Push the tip past the stabilizer and straight into the cavity until it bottoms.
4. For a receptacle style connector, insert a 1.02 mm [.040 in.] diameter pin straight into the FRONT of the contact cavity. For a plug style connector, push on mating tip of contact with a suitable device.
5. Apply pressure to remove the contact and tool from the contact cavity.

5. TOOL INSPECTION/REPLACEMENT (Figure 7)

Insertion/Extraction Tool is inspected before shipment. TE recommends that the tool be inspected immediately upon its arrival to ensure that the tool has not been damaged during shipment, and that the tool conforms to the dimensions provided in Figure 7. Customer-replaceable parts are provided in Figure 7. If the tool becomes broken or damaged, replacement and/or spare parts can be purchased by contacting:

CUSTOMER SERVICE (038-035)
 TYCO ELECTRONICS CORPORATION
 PO BOX 3608
 HARRISBURG PA 17105-3608

For tool repair service, please contact an TE Representative at 1-800-526-5136.

6. REVISION SUMMARY

Since the previous release, the last line of Figure 1 was corrected to indicate contact HD-22.

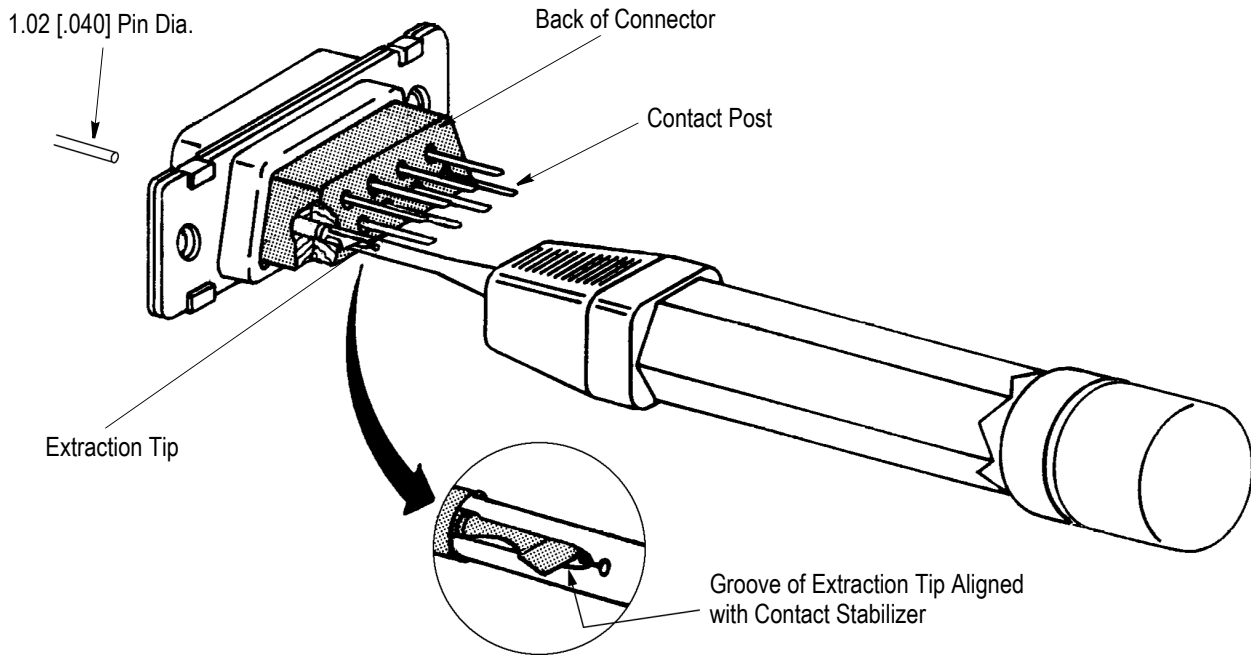
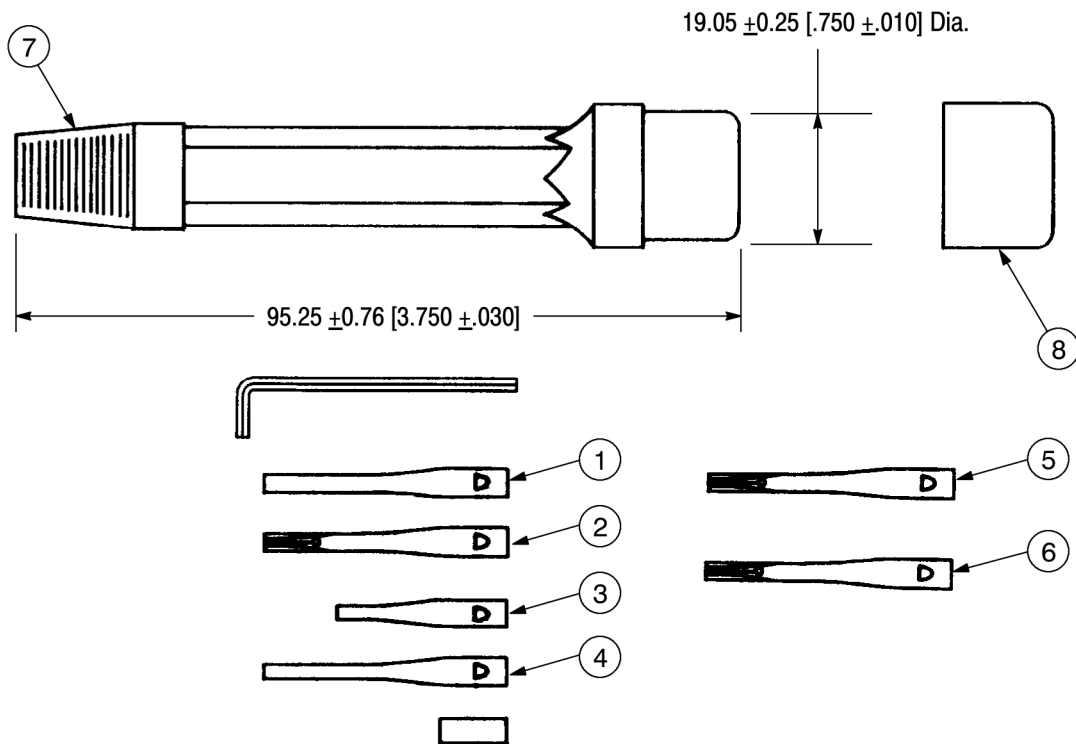

Figure 6



REPLACEMENT PARTS†

ITEM	COLOR CODE	PART NUMBER	DESCRIPTION
1	Yellow	543382-5	TIP, Insertion
2	Blue	543382-6	TIP, Extraction
3	Black	543382-7	TIP, Insertion
4	Green	543382-8	TIP, Insertion/Extraction
5	Red	1-543382-0	TIP, Extraction
6	Brown	1-543382-1	TIP, Extraction
7	----	2-21006-0	SCREW, Set No. 4-40 X .180 Lg.
8	----	2-26538-5	CAP

† Available in packs of 25 only (one plug included in each packet).

Figure 7



Компания «ЭлектроПласт» предлагает заключение долгосрочных отношений при поставках импортных электронных компонентов на взаимовыгодных условиях!

Наши преимущества:

- Оперативные поставки широкого спектра электронных компонентов отечественного и импортного производства напрямую от производителей и с крупнейших мировых складов;
- Поставка более 17-ти миллионов наименований электронных компонентов;
- Поставка сложных, дефицитных, либо снятых с производства позиций;
- Оперативные сроки поставки под заказ (от 5 рабочих дней);
- Экспресс доставка в любую точку России;
- Техническая поддержка проекта, помощь в подборе аналогов, поставка прототипов;
- Система менеджмента качества сертифицирована по Международному стандарту ISO 9001;
- Лицензия ФСБ на осуществление работ с использованием сведений, составляющих государственную тайну;
- Поставка специализированных компонентов (Xilinx, Altera, Analog Devices, Intersil, Interpoint, Microsemi, Aeroflex, Peregrine, Syfer, Eurofarad, Texas Instrument, Miteq, Cobham, E2V, MA-COM, Hittite, Mini-Circuits, General Dynamics и др.);

Помимо этого, одним из направлений компании «ЭлектроПласт» является направление «Источники питания». Мы предлагаем Вам помощь Конструкторского отдела:

- Подбор оптимального решения, техническое обоснование при выборе компонента;
- Подбор аналогов;
- Консультации по применению компонента;
- Поставка образцов и прототипов;
- Техническая поддержка проекта;
- Защита от снятия компонента с производства.



Как с нами связаться

Телефон: 8 (812) 309 58 32 (многоканальный)

Факс: 8 (812) 320-02-42

Электронная почта: org@eplast1.ru

Адрес: 198099, г. Санкт-Петербург, ул. Калинина, дом 2, корпус 4, литера А.