

High Voltage EL Lamp Driver IC

Features

- ▶ Processed with HVCMOS® technology
- ▶ 2.0 to 9.5V operating supply voltage
- ▶ DC to AC conversion
- ▶ 180V peak-to-peak typical output voltage
- ▶ Large output load capability typically 50nF
- ▶ Permits the use of high-resistance elastomeric lamp components
- ▶ Adjustable output lamp frequency to control lamp color, lamp life, and power consumption
- ▶ Adjustable converter frequency to eliminate harmonics and optimize power consumption
- ▶ Enable/disable function
- ▶ Low current draw under no load condition

Applications

- ▶ Handheld personal computers
- ▶ Electronic personal organizers
- ▶ GPS units
- ▶ Pagers
- ▶ Cellular phones
- ▶ Portable instrumentation

General Description

The Supertex HV823 is a high-voltage driver designed for driving EL lamps of up to 50nF. EL lamps greater than 50nF can be driven for applications not requiring high brightness. The input supply voltage range is from 2.0V to 9.5V. The device uses a single inductor and a minimum number of passive components. The nominal regulated output voltage that is applied to the EL lamp is $\pm 90V$. The chip can be enabled by connecting the resistors on the RSW-Osc pin and the REL-Osc pin to the VDD pin, and disabled when connected to GND.

The HV823 has two internal oscillators, a switching MOSFET and a high-voltage EL lamp driver. The frequency of the switching converter MOSFET is set by an external resistor connected between the RSW-Osc pin and the VDD supply pin. The EL lamp driver frequency is set by an external resistor connected between the REL-Osc pin and the VDD pin. An external inductor is connected between the LX pin and the VDD pin. A 0.01 μF to 0.1 μF capacitor is connected between the CS pin and the GND. The EL lamp is connected between the VA and VB pins.

The switching MOSFET charges the external inductor and discharges it into the C_s capacitor. The voltage at C_s will start to increase. Once the voltage at C_s reaches a nominal value of 90V, the switching MOSFET is turned OFF to conserve power. The output pins VA and VB are configured as an H-bridge and are switched in opposite states to achieve 180V peak-to-peak across the EL lamp.

For additional information, see Application Note ANH34.

Block Diagram

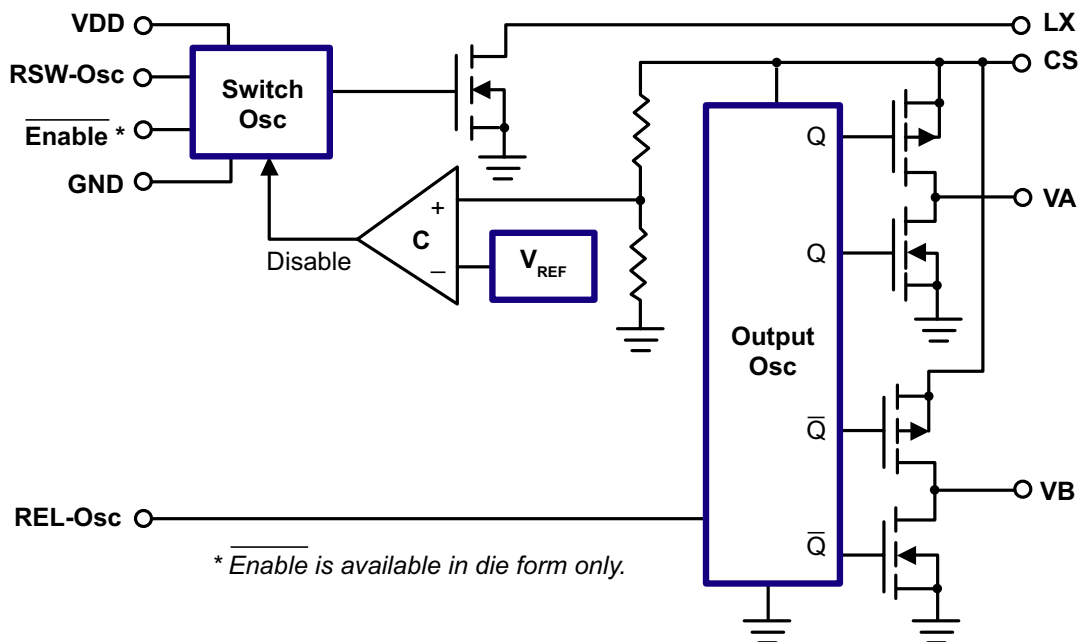

Ordering Information

Part Number	Package	Packing
HV823LG-G	8-Lead SOIC	2500/Reel

-G denotes a lead (Pb)-free / RoHS compliant package

Absolute Maximum Ratings

Parameter	Value
Supply voltage, V_{DD}	-0.5 to +10V
Output voltage, V_{CS}	-0.5 to +120V
Power dissipation	400mW
Storage temperature	-65°C to +150°C
Operating temperature	-25°C to +85°C

Stresses beyond those listed under "Absolute Maximum Ratings" may cause permanent damage to the device. These are stress ratings only, and functional operation of the device at these or any other conditions beyond those indicated in the operational sections of the specifications is not implied. Exposure to absolute maximum rating conditions for extended periods may affect device reliability. All voltages referenced to ground.

Note: All voltages referenced to GND.

Pin Configuration

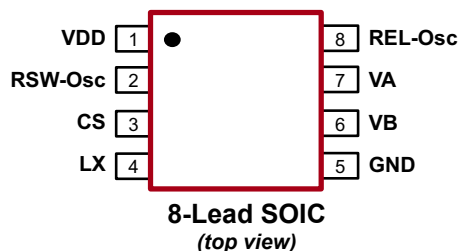

Product Marking



Y = Last Digit of Year Sealed
 WW = Week Sealed
 L = Lot Number
 LLLL = "Green" Packaging

Package may or may not include the following marks: Si or

8-Lead SOIC

Typical Thermal Resistance

Package	θ_{ja}
8-Lead SOIC	101°C/W

Recommended Operating Conditions

Sym	Parameter	Min	Typ	Max	Unit	Conditions
V_{DD}	Supply voltage	2.0	-	9.5	V	---
T_A	Operating temperature	-25	-	+85	°C	---

DC Electrical Characteristics ($V_{IN} = 3.0V$, $R_{SW} = 750K\Omega$, $R_{EL} = 2.0M\Omega$, $T_A = 25^\circ C$ unless otherwise specified)

Sym	Parameter	Min	Typ	Max	Unit	Conditions
$R_{DS(ON)}$	On resistance of switching transistor	-	2.0	6.0	Ω	$I = 100mA$
V_{CS}	Output voltage V_{CS} regulation	80	90	100	V	$V_{IN} = 2.0V$ to $9.5V$
$V_A - V_B$	Output peak-to-peak voltage	160	180	200	V	$V_{IN} = 2.0V$ to $9.5V$
I_{DDQ}	Quiescent V_{DD} supply current, disabled	-	30	100	nA	$R_{SW-OSC} = Low$
I_{DD}	V_{DD} supply current	-	150	200	μA	$V_{IN} = 3.0V$. See Fig.1
		-	-	300	μA	$V_{IN} = 5.0V$. See Fig.2
		-	-	500	μA	$V_{IN} = 9.0V$. See Fig.3
I_{IN}	Input current including inductor current	-	25	33	mA	$V_{IN} = 3.0V$. See Fig.1
V_{CS}	Output voltage on V_{CS}	60	70	85	V	$V_{IN} = 3.0V$. See Fig.1
f_{EL}	$V_A - V_B$ output drive frequency	330	380	450	Hz	$V_{IN} = 3.0V$. See Fig.1
f_{SW}	Inductor switching frequency	50	60	70	KHz	$V_{IN} = 3.0V$. See Fig.1
D	Switching transistor duty cycle	-	88	-	%	---

Fig. 1: Test Circuit, $V_{IN} = 3.0V$ (Low input current with moderate output brightness)

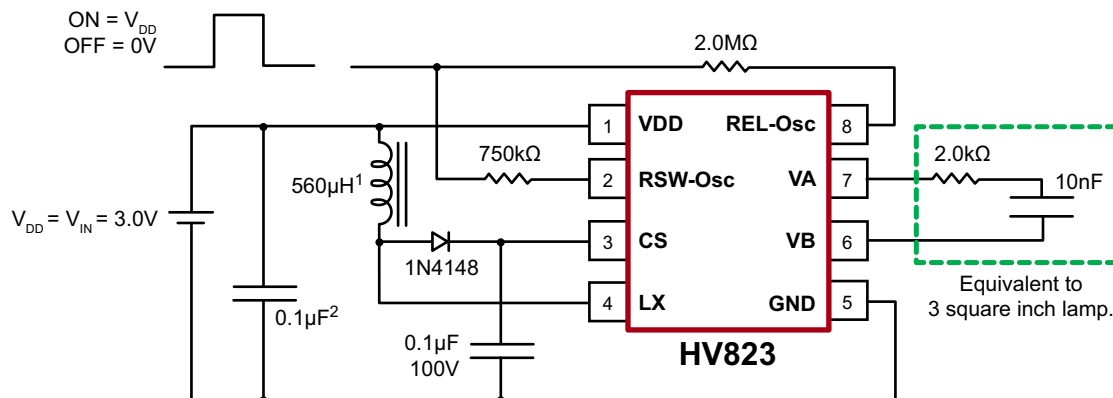

For additional information, see Application Notes AN-H33 and AN-H34.

Typical Performance

Lamp Size	V_{IN}	I_{IN}	V_{CS}	f_{EL}	Brightness
3.0in ²	3.0V	25mA	65V	385Hz	6.5ft-lm

Notes:

- Murata part # LQH4N561K04 (DC resistance < 14.5Ω)
- Larger values may be required depending upon supply impedance.

Typical Performance Curves for Fig. 1 using 3.0in² EL Lamp

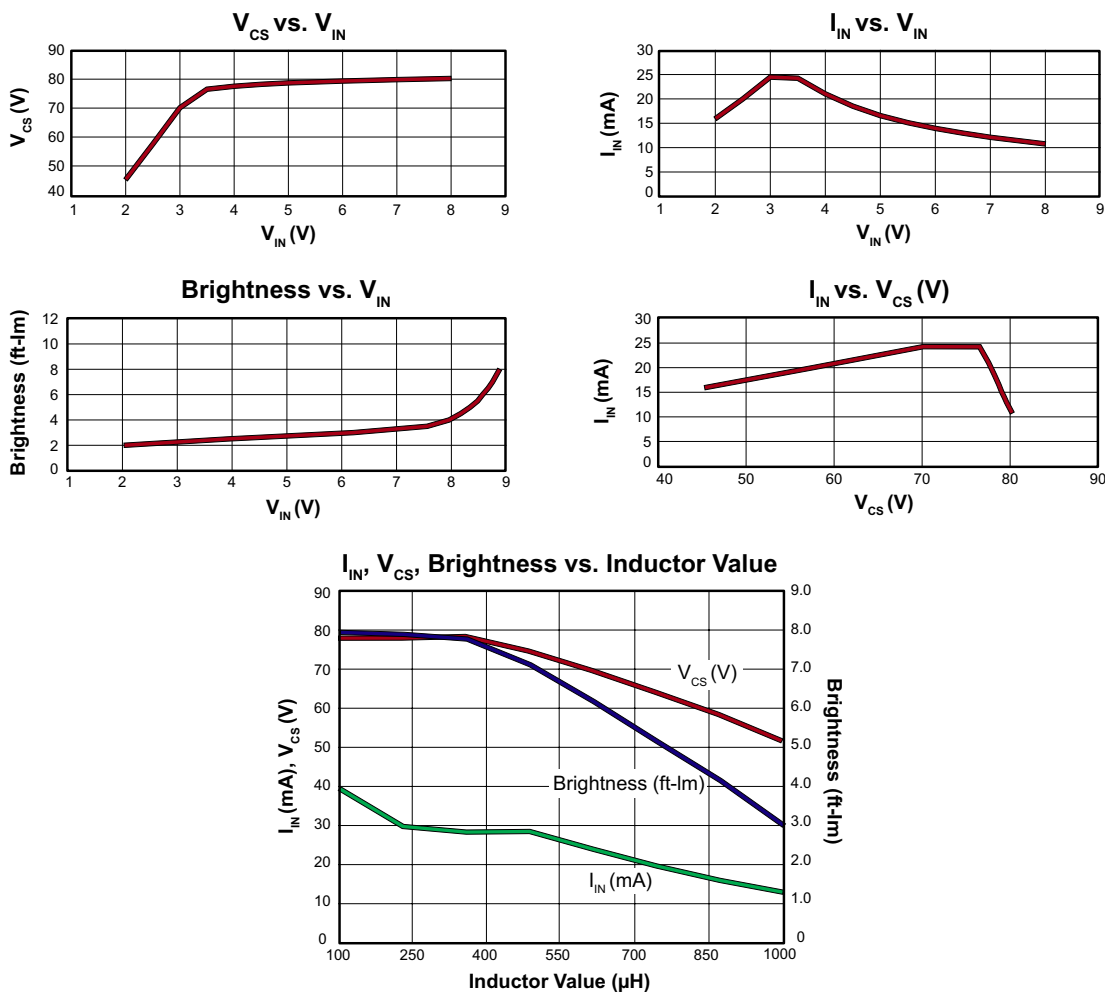
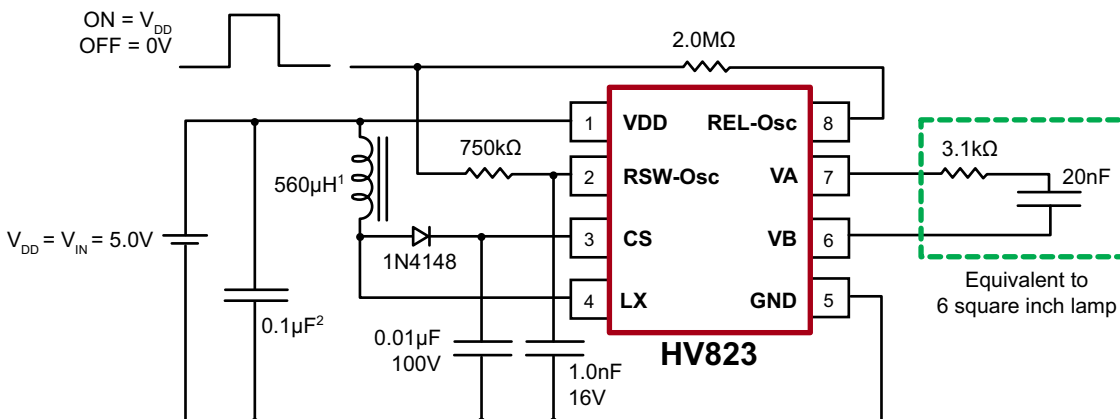

Fig. 2: Typical 5.0V Application



For additional information, see Application Notes AN-H33 and AN-H34.

Typical Performance

Lamp Size	V_{IN}	I_{IN}	V_{CS}	f_{EL}	Brightness
6.0in ²	5.0V	25mA	75V	380Hz	6.5ft-lm

Notes:

- Murata part # LQH4N561K04 (DC resistance < 14.5Ω)
- Larger values may be required depending upon supply impedance.

Typical Performance Curves for Fig. 2 using 6.0in² EL Lamp

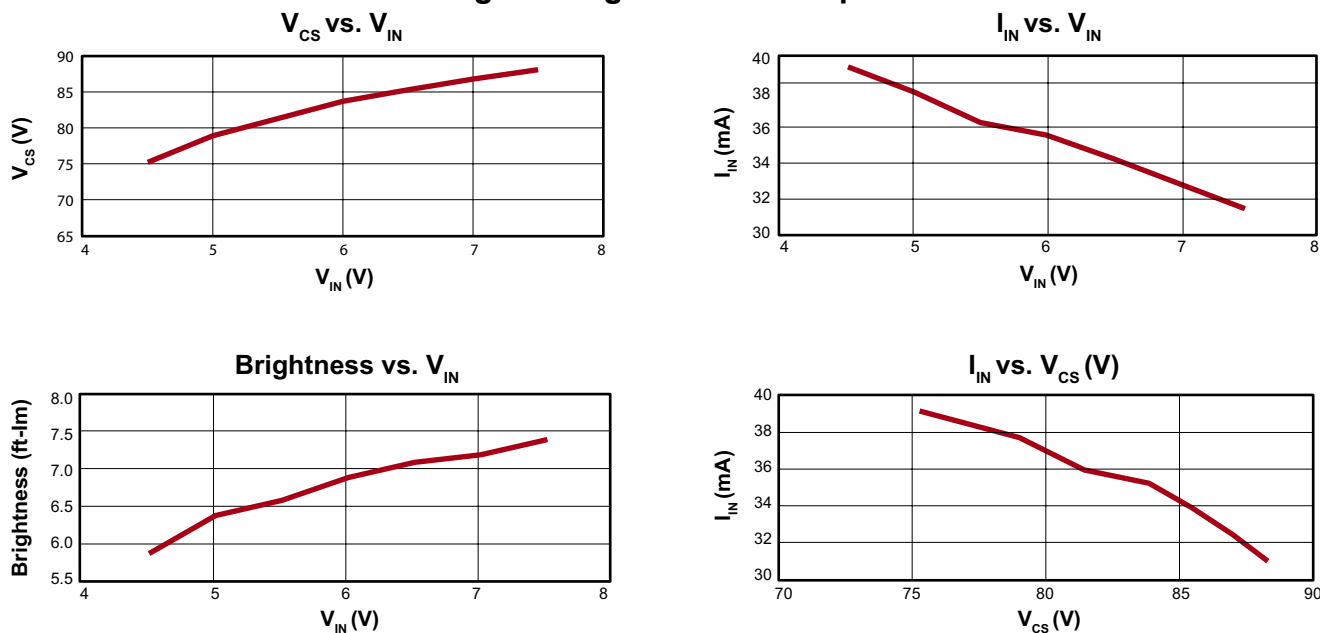
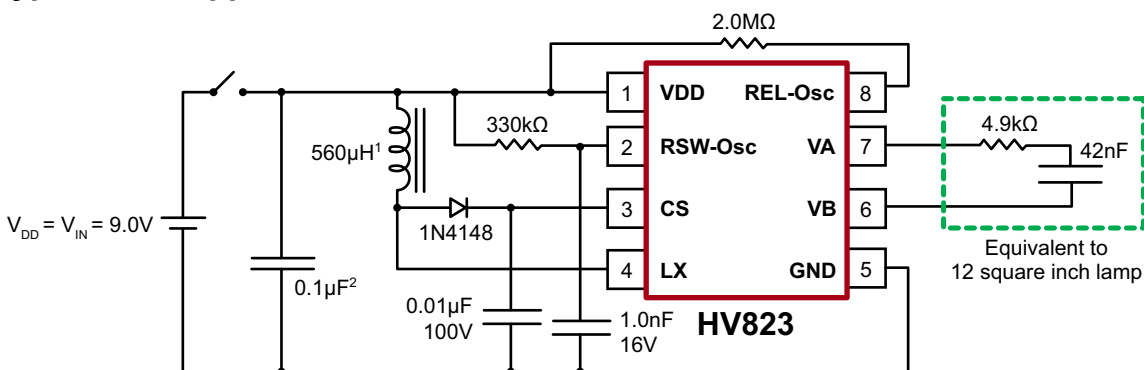

Fig. 3: Typical 9.0V Application



For additional information, see Application Notes AN-H33 and AN-H34.

Typical Performance

Lamp Size	V_{IN}	I_{IN}	V_{CS}	f_{EL}	Brightness
12.0in ²	9.0V	30mA	75V	380Hz	8.5ft-lm

Notes:

1. Murata part # LQH4N561K04 (DC resistance < 14.5Ω)
2. Larger values may be required depending upon supply impedance.

Typical Performance Curves for Fig. 3 using 12.0in² EL Lamp

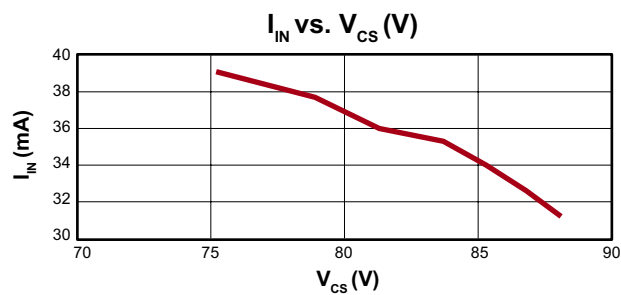
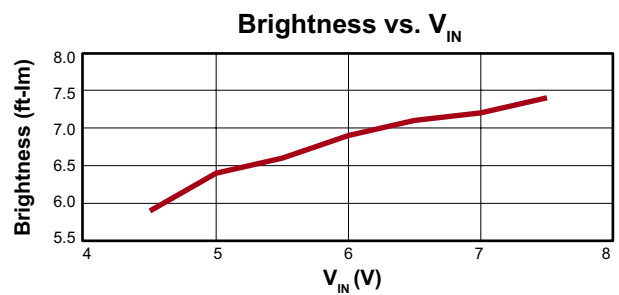
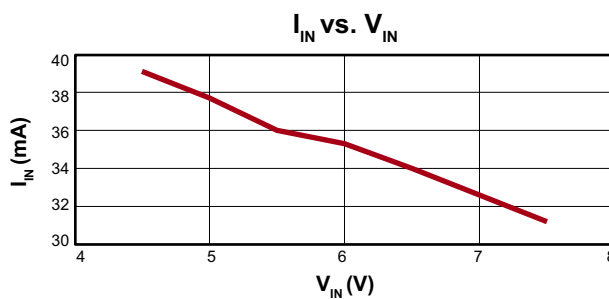
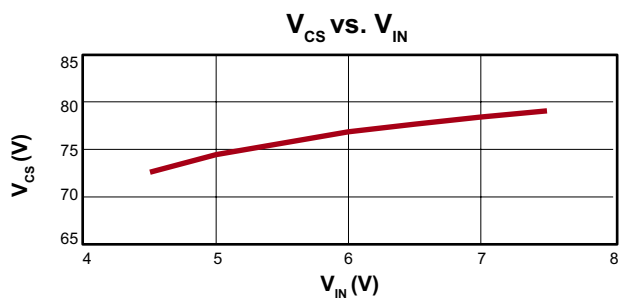

Enable/Disable Configuration

The HV823 can be easily enabled and disabled via a logic control signal on the R_{SW} and R_{EL} resistors as shown in Fig. 4. The control signal can be from a microprocessor. R_{SW} and R_{EL} are typically very high values, therefore, only 10's of microamperes will be drawn from the logic signal when it is at a logic high (enable) state. When the microprocessor signal is high the device is enabled and when the signal is low, it is disabled.

Enable/Disable Table

R_{SW} Resistor	HV823
V_{DD}	Enable
0V	Disable

Fig. 4: Enable/Disable Configuration

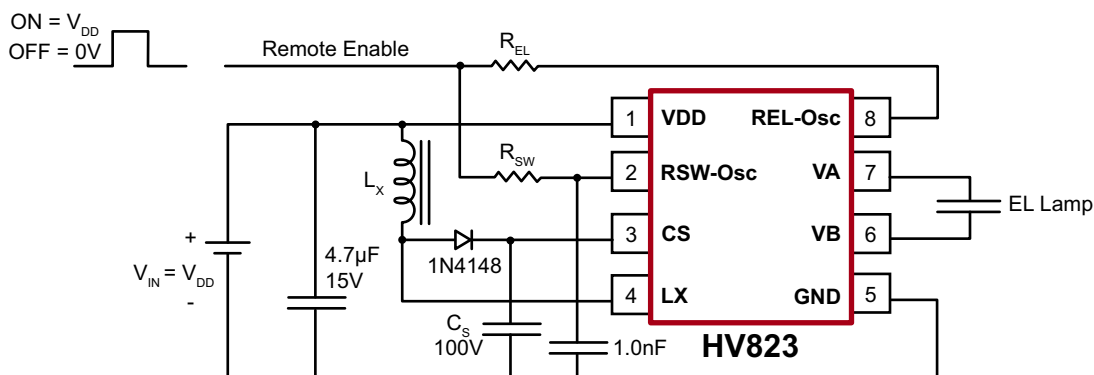

Split Supply Configuration Using a Single Cell (1.5V) Battery

The HV823 can also be used for handheld devices operating from a single cell 1.5V battery where a regulated voltage is available. This is shown in Fig. 5. The regulated voltage can be used to run the internal logic of the HV823. The amount of current necessary to run the internal logic is typically 100µA

at a V_{DD} of 3.0V. Therefore, the regulated voltage could easily provide the current without being loaded down. The HV823 used in this configuration can also be enabled/disabled via logic control signal on the R_{SW} and R_{EL} resistors as shown in Fig. 4.

Split Supply Configuration for Battery Voltages of Higher than 9.5V

Fig. 5 can also be used with high battery voltages, such as 12V, as long as the input voltage, V_{IN} , to the HV823 device is within its specifications of 2.0V to 9.5V.

Fig. 5: Split Supply Configuration

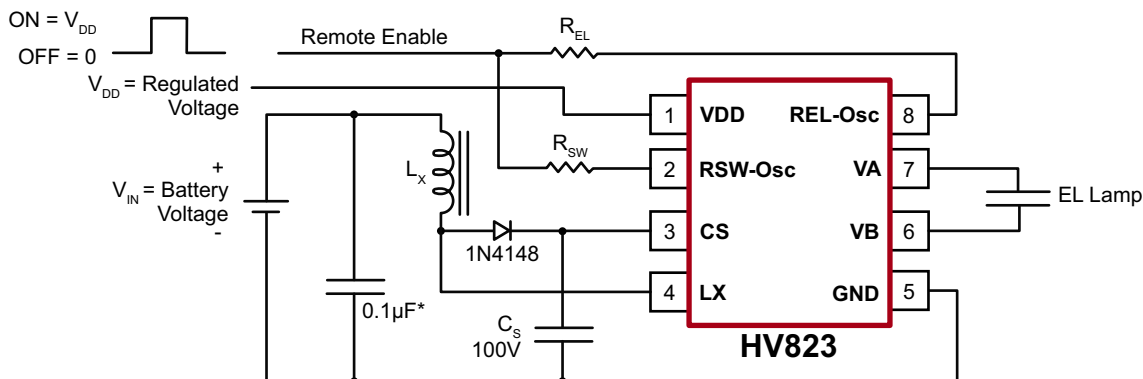

External Component Description

External Component	Selection Guide Line
Diode	Fast reverse recovery diode, 1N4148 or equivalent.
CS Capacitor	0.01 μ F to 0.1 μ F, 100V capacitor to GND is used to store the energy transferred from the inductor.
REL-Osc	<p>The EL lamp frequency is controlled via an external R_{EL} resistor connected between REL-Osc and VDD pins of the device. The lamp frequency increases as R_{EL} decreases. As the EL lamp frequency increases, the amount of current drawn from the battery will increase and the output voltage V_{CS} will decrease. The color of the EL lamp is dependent upon its frequency.</p> <p>A 2.0MΩ resistor would provide lamp frequency of 330 to 450Hz. Decreasing the R_{EL-Osc} by a factor of 2 will increase the lamp frequency by a factor of 2.</p>
RSW-Osc	The switching frequency of the converter is controlled via an external resistor, R_{SW} between the RSW-Osc and VDD pins of the device. The switching frequency increases as R_{SW} decreases. With a given inductor, as the switching frequency increases, the amount of current drawn from the battery will decrease and the output voltage, V_{CS} , will also decrease.
CSW Capacitor	A 1.0nF capacitor is recommended on RSW-Osc to GND when a 0.01 μ F C_S capacitor is used. This capacitor is used to shunt any switching noise that may couple into the RSW-OSC pin. The C_{SW} capacitor may also be needed when driving large EL lamp due to increase in switching noise. A C_{SW} larger than 1.0nF is not recommended.
LX Inductor	<p>The inductor LX is used to boost the low input voltage by inductive flyback. When the internal switch is on, the inductor is being charged. When the internal switch is off, the charge stored in the inductor will be transferred to the high voltage capacitor C_S. The energy stored in the capacitor is connected to the internal H-bridge and therefore to the EL lamp. In general, smaller value inductors, which can handle more current, are more suitable to drive larger size lamps. As the inductor value decreases, the switching frequency of the inductor (controlled by R_{SW}) should be increased to avoid saturation.</p> <p>560μH Murata inductors with 14.5Ω series DC resistance is typically recommended. For inductors with the same inductance value but with lower series DC resistance, lower R_{SW} value is needed to prevent high current draw and inductor saturation.</p>
Lamp	As the EL lamp size increases, more current will be drawn from the battery to maintain high voltage across the EL lamp. The input power, ($V_{IN} \times I_{IN}$), will also increase. If the input power is greater than the power dissipation of the package (400mW), an external resistor in series with one side of the lamp is recommended to help reduce the package power dissipation.

8-Lead SOIC (Narrow Body) Package Outline (LG)

4.90x3.90mm body, 1.75mm height (max), 1.27mm pitch

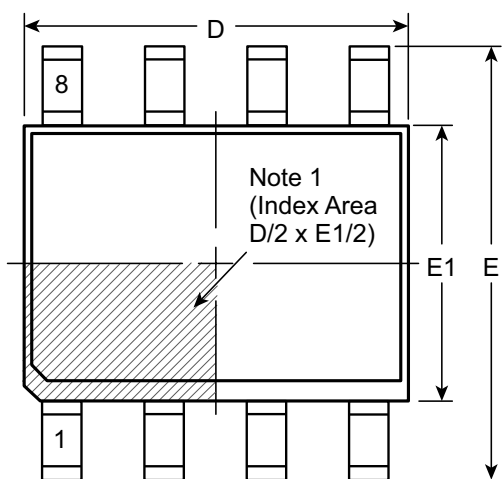

Top View

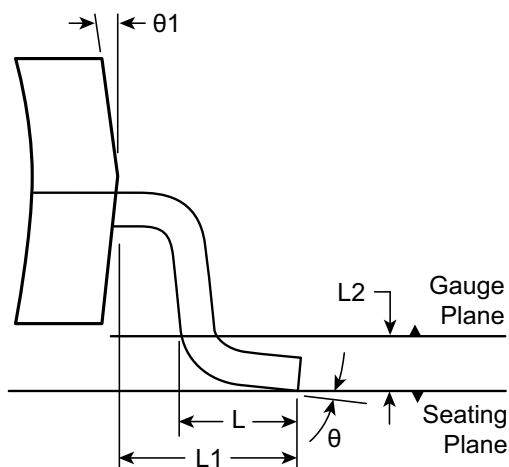

View B

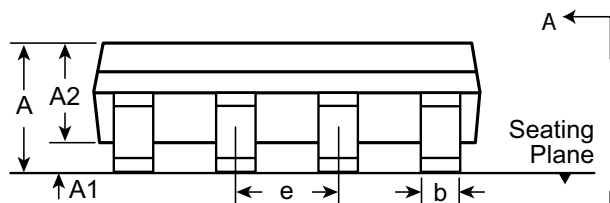

Side View

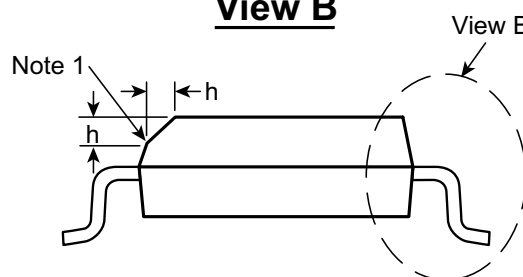

View A-A

Note:
 1. This chamfer feature is optional. A Pin 1 identifier must be located in the index area indicated. The Pin 1 identifier can be: a molded mark/identifier; an embedded metal marker; or a printed indicator.

Symbol	A	A1	A2	b	D	E	E1	e	h	L	L1	L2	θ	θ1				
Dimension (mm)	MIN	1.35*	0.10	1.25	0.31	4.80*	5.80*	3.80*	1.27 BSC	0.25	0.40	1.04 REF	0.25	0°	5°			
	NOM	-	-	-	-	4.90	6.00	3.90		-	-		1.04			0.25	-	-
	MAX	1.75	0.25	1.65*	0.51	5.00*	6.20*	4.00*		0.50	1.27		1.04			0.25	8°	15°

JEDEC Registration MS-012, Variation AA, Issue E, Sept. 2005.

* This dimension is not specified in the JEDEC drawing.

Drawings are not to scale.

Supertex Doc. #: DSPD-8SOLGTG, Version I041309.

(The package drawing(s) in this data sheet may not reflect the most current specifications. For the latest package outline information go to <http://www.supertex.com/packaging.html>.)

Supertex inc. does not recommend the use of its products in life support applications, and will not knowingly sell them for use in such applications unless it receives an adequate "product liability indemnification insurance agreement." **Supertex inc.** does not assume responsibility for use of devices described, and limits its liability to the replacement of the devices determined defective due to workmanship. No responsibility is assumed for possible omissions and inaccuracies. Circuitry and specifications are subject to change without notice. For the latest product specifications refer to the **Supertex inc.** (website: <http://www.supertex.com>)



Компания «ЭлектроПласт» предлагает заключение долгосрочных отношений при поставках импортных электронных компонентов на взаимовыгодных условиях!

Наши преимущества:

- Оперативные поставки широкого спектра электронных компонентов отечественного и импортного производства напрямую от производителей и с крупнейших мировых складов;
- Поставка более 17-ти миллионов наименований электронных компонентов;
- Поставка сложных, дефицитных, либо снятых с производства позиций;
- Оперативные сроки поставки под заказ (от 5 рабочих дней);
- Экспресс доставка в любую точку России;
- Техническая поддержка проекта, помощь в подборе аналогов, поставка прототипов;
- Система менеджмента качества сертифицирована по Международному стандарту ISO 9001;
- Лицензия ФСБ на осуществление работ с использованием сведений, составляющих государственную тайну;
- Поставка специализированных компонентов (Xilinx, Altera, Analog Devices, Intersil, Interpoint, Microsemi, Aeroflex, Peregrine, Syfer, Eurofarad, Texas Instrument, Miteq, Cobham, E2V, MA-COM, Hittite, Mini-Circuits, General Dynamics и др.);

Помимо этого, одним из направлений компании «ЭлектроПласт» является направление «Источники питания». Мы предлагаем Вам помощь Конструкторского отдела:

- Подбор оптимального решения, техническое обоснование при выборе компонента;
- Подбор аналогов;
- Консультации по применению компонента;
- Поставка образцов и прототипов;
- Техническая поддержка проекта;
- Защита от снятия компонента с производства.



Как с нами связаться

Телефон: 8 (812) 309 58 32 (многоканальный)

Факс: 8 (812) 320-02-42

Электронная почта: org@eplast1.ru

Адрес: 198099, г. Санкт-Петербург, ул. Калинина, дом 2, корпус 4, литера А.