

DC-DC Converter Specification

MPDRX021S

1. Application

This specification applies to DC-DC Converter for telecommunication / data-communication equipment, MPDRX021S.

For any other application, please contact us before using this product.

2. Customer Reference

Customer Spec. Number
Customer Part Number

3. Murata Part Number

MPDRX021S

4. Appearance, Dimensions

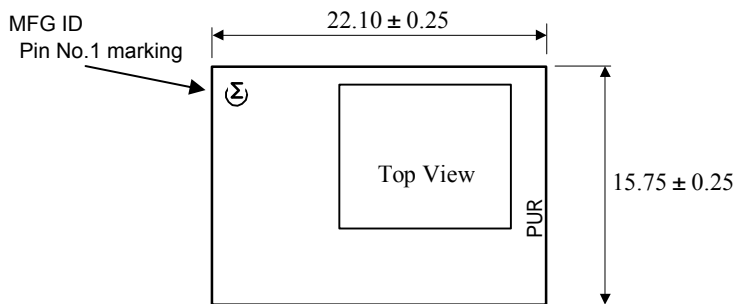

()...reference value
Tolerance is not accumulated.

[unit : mm]

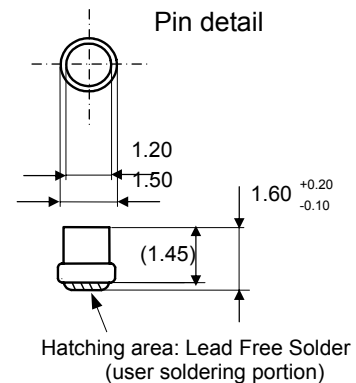
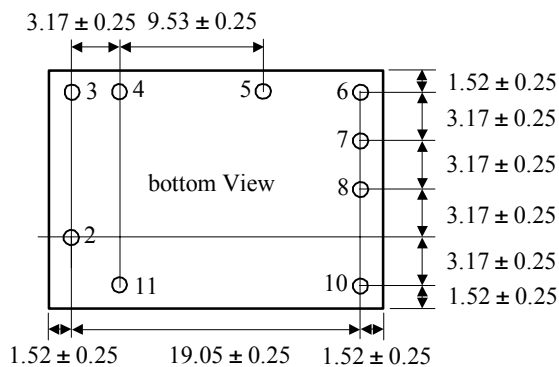
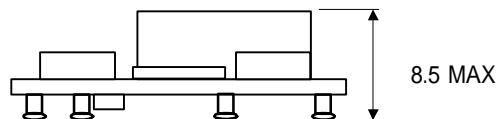

Marking

- (1) Pin No.1 Marking / MFG ID 
- (2) Parts No. PUR
- (3) Lot No.

Production factory Mark

Production Year

Production Month (1,2,3,...9,O,N,D)

⚠ Note:

1. This datasheet is downloaded from the website of Murata Manufacturing co., ltd. Therefore, it's specifications are subject to change or our products in it may be discontinued without advance notice. Please check with our sales representatives or product engineers before ordering.
2. This datasheet has only typical specifications because there is no space for detailed specifications. Therefore, please approve our product specifications or transact the approval sheet for product specifications before ordering.

5. Pin Number and Function

Pin No.	Symbol	Function
2	Vin	Input voltage
3,4	GND	GND
5	Vout	Output Voltage
6	+SENSE	Output voltage +sense
7	-SENSE	Output voltage -sense
8	Vout Adjust	Output Voltage Adjustment
10	Track	Tracking Function
11	ON/OFF	Remote ON/OFF Control

6. Block Diagram

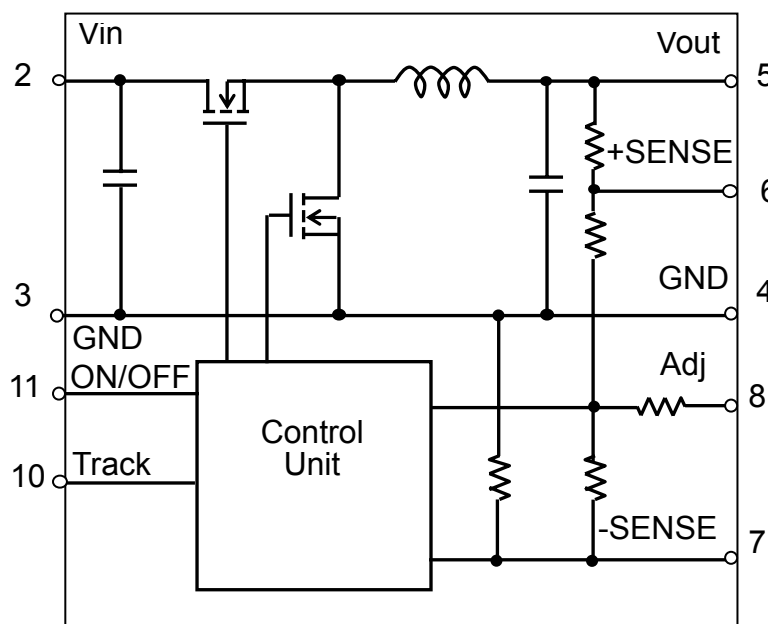

7. Environmental Conditions

7.1 Operating Temperature Range	-40°C ~ +85°C
7.2 Storage Temperature Range	-40°C ~ +85°C
7.3 Operating Humidity Range	20% ~ 85% (No water condenses in any cases.)
7.4 Storage Humidity Range	10% ~ 90% (No water condenses in any cases.)

8. Absolute Maximum Rating

Item	Unit	Absolute Rating	Remarks
Minimum Input Voltage	V	0	
ON/OFF Pin, Track Pin Maximum input Voltage	V	Vin	

No voltage, no matter how instantaneous, shall be applied beyond the absolute maximum voltage rating to this product. If you apply any voltage over this limit the product characteristics will deteriorate or the product itself will be destroyed. Even though it may continue operating for a while after the over-voltage event, its life will likely be shortened significantly. Reliability and life of the module may degrade similarly if the maximum operating voltage rating is continuously exceeded. This product is designed to operate within the maximum operating voltage rating specification.

⚠ Note:

- This datasheet is downloaded from the website of Murata Manufacturing co., ltd. Therefore, it's specifications are subject to change or our products in it may be discontinued without advance notice. Please check with our sales representatives or product engineers before ordering.
- This datasheet has only typical specifications because there is no space for detailed specifications. Therefore, please approve our product specifications or transact the approval sheet for product specifications before ordering.

9. Characteristics

9.1. Electrical Characteristics

9.1.1. Input Characteristics (Ta= 25°C)

Item	Symbol	Condition	Value			Unit
			Min.	Typ.	Max.	
Input Voltage Range	Vin		4.5	5.0	5.5	V

9.1.2. Interface Characteristics (Ta= 25°C)

Item	Symbol	Condition	Value			Unit	
			Min.	Typ.	Max.		
ON/OFF pin High Voltage	VIH	ON/OFF pin is pulled up to Vin inside of the DC-DC converter. If ON/OFF pin is left open, the DC-DC converter shall be "ON". This pin will be pulled down to GND inside the DC-DC converter when UVLO events occur. Please do NOT connect this pin to power supply with low impedance line, so as not to damage the converter.					
ON/OFF pin Low Voltage	VIL	If ON/OFF pin is pulled down to GND, the DC-DC converter shall be "OFF".	OFF	0	-	0.3	V

9.1.3. General Characteristics (Ta= 25°C)

Item	Symbol	Condition	Value			Unit	
			Min.	Typ.	Max.		
Output Voltage Range	Vout		0.85	1.1	1.8	V	
Output Current	Iout	See the Thermal derating curve in clause 9.1.4	0	-	10	A	
Output Voltage Tolerance	Vo tol	Over Io, Temperature range Vin=4.5 ~ 5.5V	Vo=0.85 ~ 1.2V	-1.5	-	+1.5	%Vo
			Vo=1.2 ~ 1.8V	-2.0	-	+2.0	
Ripple Voltage	Vrpl	Vin=5V, Vout=1.2V, Iout=10A BW =20MHz,	-	10	-	mV(pp)	
Efficiency	EFF	Vin =5V, Vout=1.1V, Iout=10A	-	86	-	%	
Operating Frequency	Freq	Vin=5V, Vout=1.1V	-	660	-	kHz	
Short Circuit Protection	SCP	If output is shorted to GND, DC-DC converter will be interrupted (hiccup mode operation). After correction of the abnormal condition, DC-DC converter will automatically restart.	-	23	-	A	
External Input Capacitor	Cin	When input voltage is ideal voltage source	-	330	-	μF	
External Output Capacitor	Cout	Low ESR tantalum Capacitor When input voltage is ideal voltage source	1000		5000	μF	
Tracking slew rate capability			-	-	1	V/ms	

This DC-DC converter thermally shuts down when temperature of a control IC reaches to 180°C typically.

 Caution

The above electrical characteristics are guaranteed with the condition that the impedance of the input voltage source is sufficiently low as shown in section 10. Connecting an input inductance or using an input power supply with output inductance may cause an unstable operation of this device. Please check the proper operation of this device with the peripheral circuits on your system.

 Note:

1. This datasheet is downloaded from the website of Murata Manufacturing co., ltd. Therefore, it's specifications are subject to change or our products in it may be discontinued without advance notice. Please check with our sales representatives or product engineers before ordering.
2. This datasheet has only typical specifications because there is no space for detailed specifications. Therefore, please approve our product specifications or transact the approval sheet for product specifications before ordering.

9.1.4. Thermal Derating

Vin=4.5 ~ 5.5V

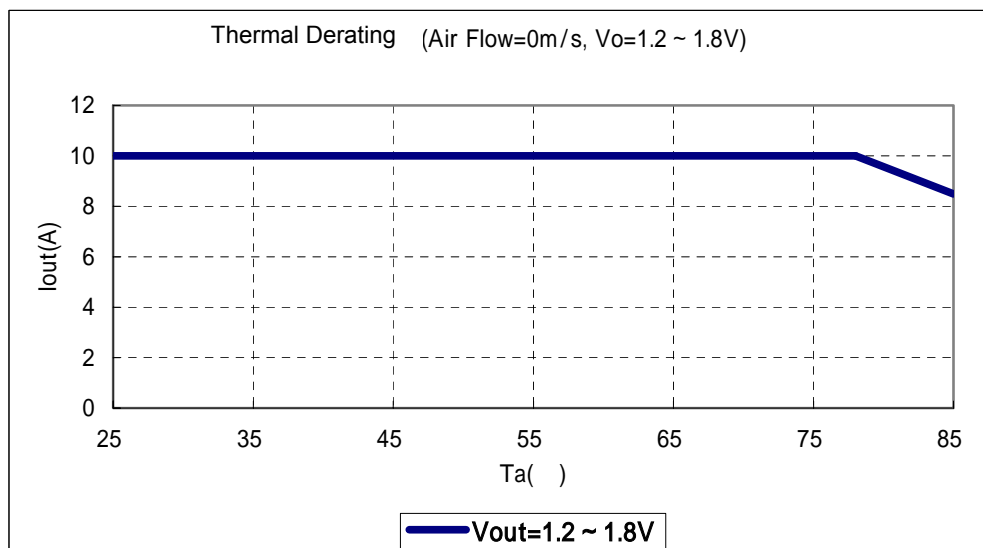
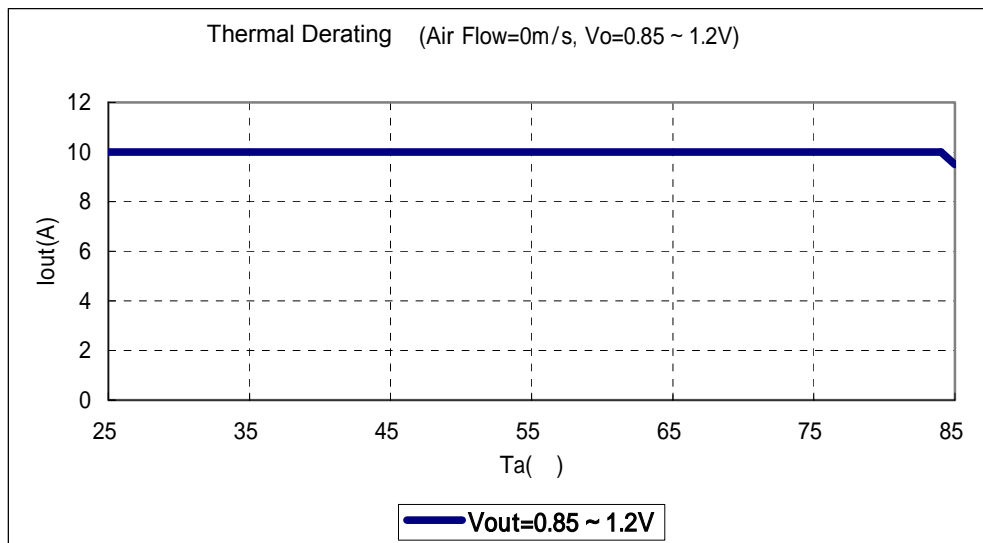

The above derating limits apply to this product soldered directly to 101.6*180mm*1.6mm PCB. Any adjacent parts of high temperature may cause overheating. For reliable operation, please ensure that the FET temperature of this product is maintained below 120°C and the inductor temperature is below 106°C.

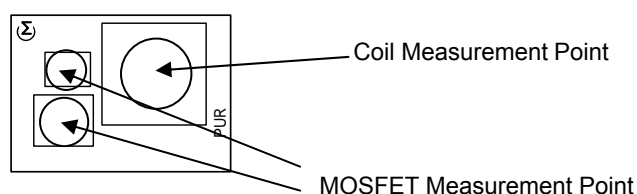

⚠ Note:

1. This datasheet is downloaded from the website of Murata Manufacturing co., ltd. Therefore, it's specifications are subject to change or our products in it may be discontinued without advance notice. Please check with our sales representatives or product engineers before ordering.
2. This datasheet has only typical specifications because there is no space for detailed specifications. Therefore, please approve our product specifications or transact the approval sheet for product specifications before ordering.

9.1.5. The Auto-Track Function

- Track function is available 20ms after input voltage is applied and ON/OFF becomes high. During this period, Track pin should be connected to GND.
- The output voltage tracks the external voltage signal one-to-one volt basis. When the external voltage signal is higher than the set point voltage of the converter, the output voltage remains at the set point voltage. So the external voltage signal must be set higher than the set point voltage of the converter.
- By connecting the Track pin of some converters, these converters can be controlled by a common signal.
- Please short the Track pin to V_{in} , when the sequence function is not used.

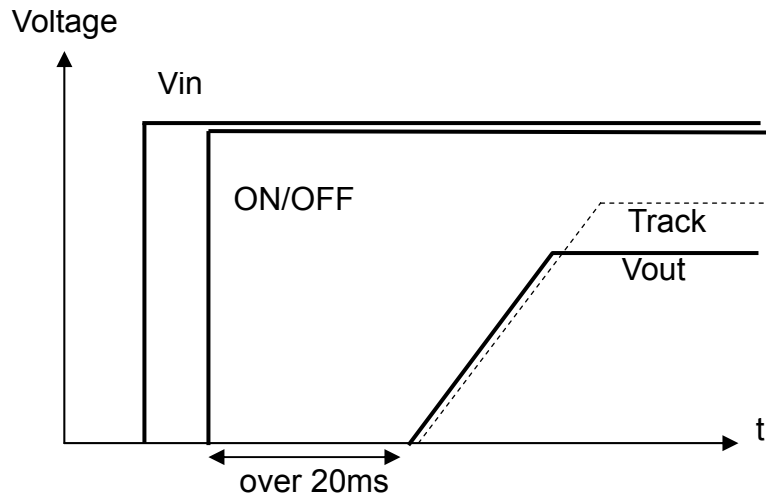

Power up with Track

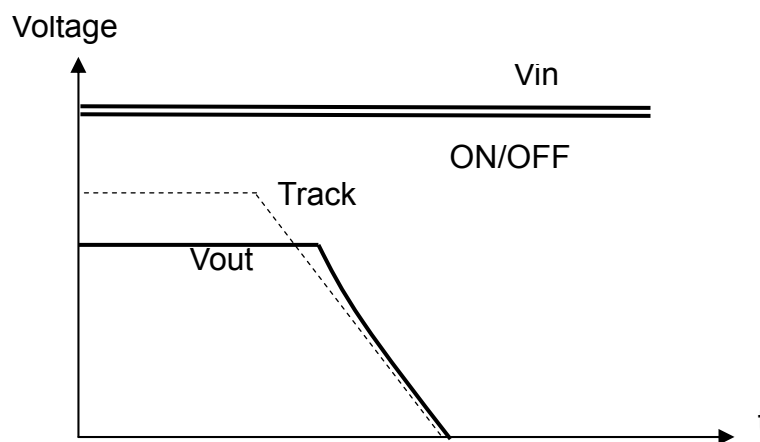

Power down with Track

Note:

1. This datasheet is downloaded from the website of Murata Manufacturing co., ltd. Therefore, it's specifications are subject to change or our products in it may be discontinued without advance notice. Please check with our sales representatives or product engineers before ordering.
2. This datasheet has only typical specifications because there is no space for detailed specifications. Therefore, please approve our product specifications or transact the approval sheet for product specifications before ordering.

9.2. Operation Information

9.2.1. Output Voltage Sensing

By connecting the SENSE-pin to the load, the output voltage drop due to the PCB wiring may be compensated for (within 10cm).

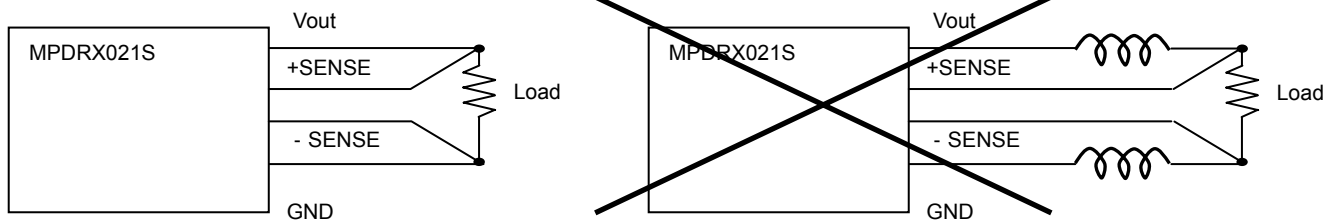

Please do NOT connect SENSE-pin to the output of LC filter that is set to the Vout line. When using this way, this product will not operate properly.

< Caution >

Please connect SENSE-pin to Vout-pin nearby the product, if sense function is not used.

9.2.2. ON/OFF control

Using the ON/OFF feature, the operation of this product can be disabled without removal of the input voltage. Sequencing of a power supply system and power-saving control can be easily achieved using this function.

When ON/OFF-pin(11pin) is left open Output Voltage =ON
 When ON/OFF-pin(11pin) is connected to GND Output Voltage =OFF

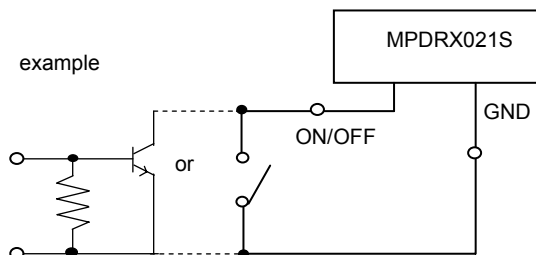

< Caution >

ON/OFF pin is pulled up inside of the DC-DC converter, so voltage appears up to V_{in} at ON/OFF pin.

9.2.3. Parallel Operation.

This product is incapable of parallel operation

⚠ Note:

1. This datasheet is downloaded from the website of Murata Manufacturing co., ltd. Therefore, it's specifications are subject to change or our products in it may be discontinued without advance notice. Please check with our sales representatives or product engineers before ordering.
2. This datasheet has only typical specifications because there is no space for detailed specifications. Therefore, please approve our product specifications or transact the approval sheet for product specifications before ordering.

9.2.4. Output Voltage Adjustment

The output voltage can be adjusted from 0.85V to 1.8V by connecting a resistor between Adjust-pin (8Pin) to -SENSE-pin (7Pin).

The following equation gives the required external-resistor values to adjust the output voltage to the required Vout. It is highly recommended that evaluation of the characteristics of this DC-DC converter's operation under your board conditions be thoroughly conducted.

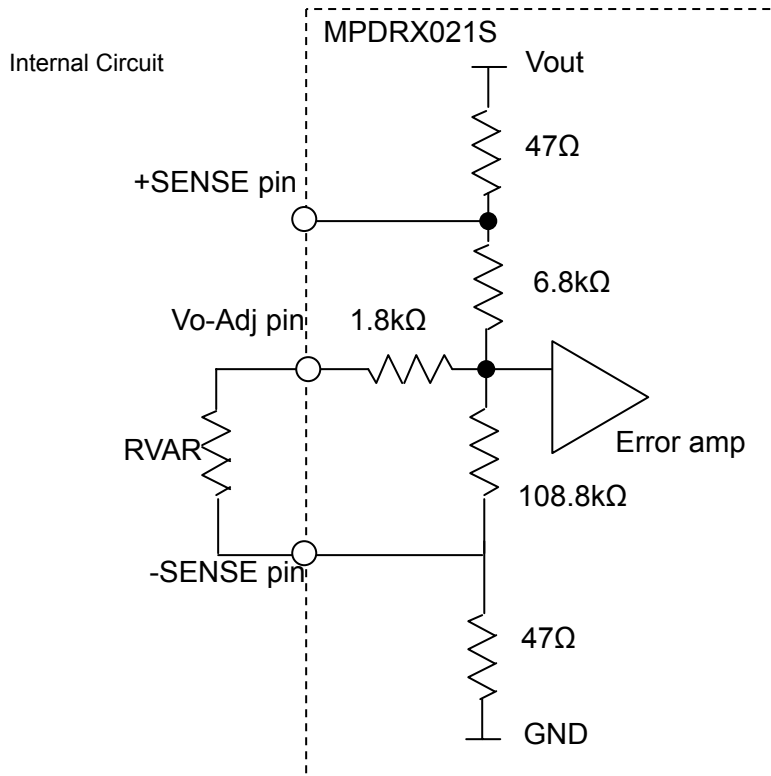

$$RVAR = \frac{5440}{V_{out}[V] - 0.85[V]} - 1800[\text{ohm}]$$

< RVAR Calculation Example >

Vout(V)	Calculated RVAR(Ω)	RVAR Example(Ω)
1.8	3926	3.9k + 27
1.5	6569	6.3k + 270
1.2	13743	13k + 750
1.0	34467	33k + 1.5k
0.7	∞	Open

Note:

1. This datasheet is downloaded from the website of Murata Manufacturing co., ltd. Therefore, it's specifications are subject to change or our products in it may be discontinued without advance notice. Please check with our sales representatives or product engineers before ordering.
2. This datasheet has only typical specifications because there is no space for detailed specifications. Therefore, please approve our product specifications or transact the approval sheet for product specifications before ordering.

.2.5. Rest Condition

In order to reset all function, the input Voltage is set under 0.5V for Min.100 m second or ON/OFF pin voltage is set under 1.0V for Min 10m second.

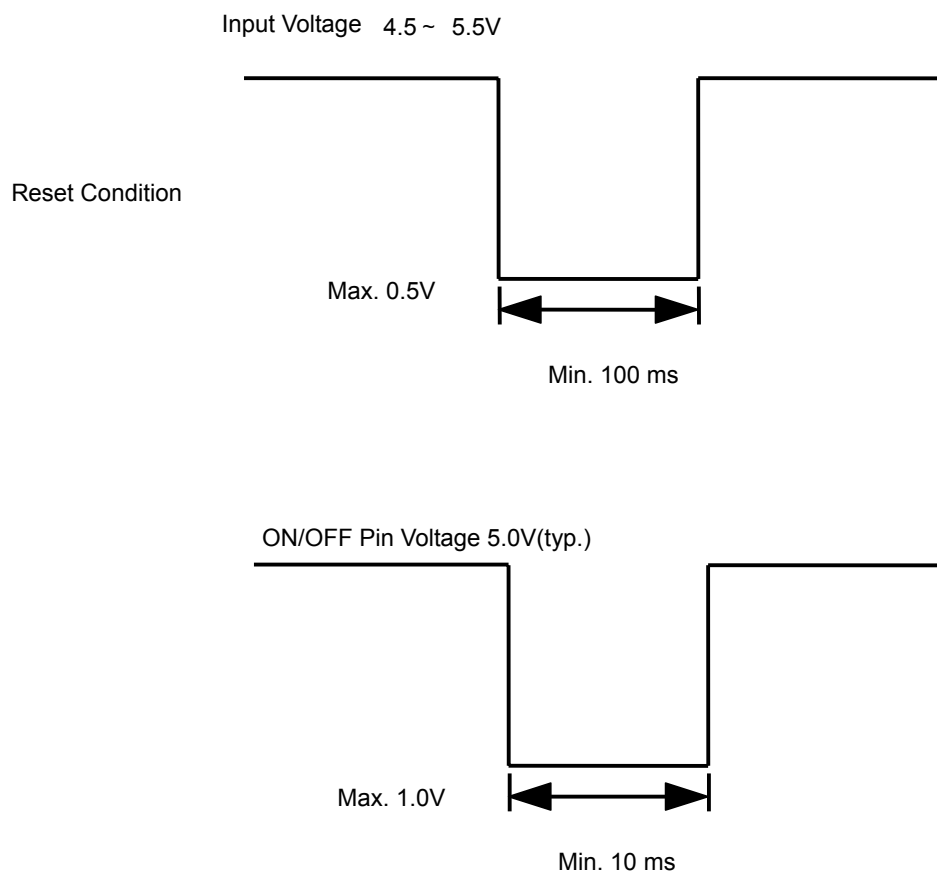

⚠ Note:

1. This datasheet is downloaded from the website of Murata Manufacturing co., ltd. Therefore, it's specifications are subject to change or our products in it may be discontinued without advance notice. Please check with our sales representatives or product engineers before ordering.
2. This datasheet has only typical specifications because there is no space for detailed specifications. Therefore, please approve our product specifications or transact the approval sheet for product specifications before ordering.

9.3. Reliability

9.3.1. Humidity

According to JIS-C-0022.

40 ± 2°C, 90 to 95%RH, 100 hours. Leave for 4 hours at room temperature.

No damage in appearance and no deviation from electrical characteristics (section 9.1.).

9.3.2. Temperature Cycles

Repeat cycle 5 times. Leave 2 hours at room temp.

No damage in appearance and no deviation from electrical characteristics (section 9.1.).

Step	Condition	Time
1	-40°C ± 3°C	30 minutes
2	Room Temp.	5-10 minutes
3	+85°C ± 2°C	30 minutes
4	Room Temp.	5-10 minutes

9.3.3. Vibration

10 to 55Hz, 1.5mm amplitude (1minute cycle), 1 hour for each of X, Y, Z directions.

No damage in appearance and no deviation from electrical characteristics (section 9.1.).

9.3.4. Mechanical Shock

20G, 1 time for each X, Y, Z directions.

No damage in appearance and no deviation from electrical characteristics (section 9.1.).

10. Test Circuit

In the following test circuit, the initial values under item 9.1. should be met.

10.1. General Measure Circuit

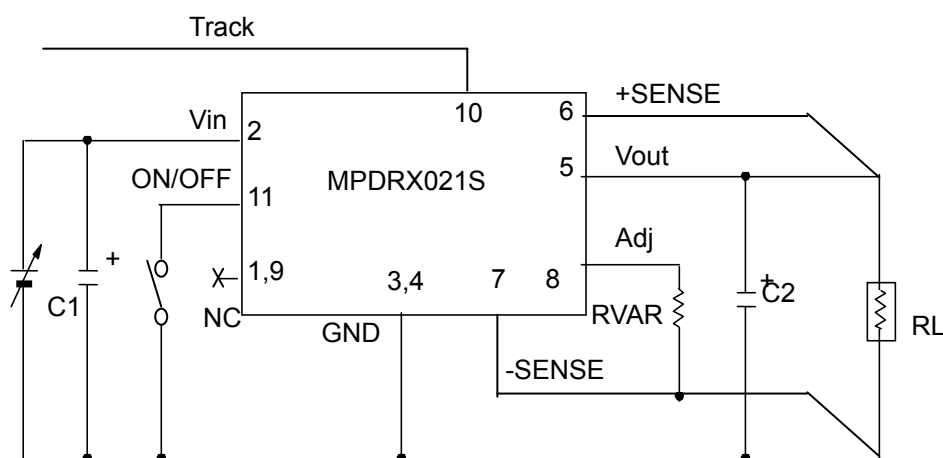

- C1 : 300 μ F / 8V Low ESR tantalum Capacitor
ex.) Panasonic: EEFUE01J151R(150 μ F/8V) ×2
- C2 : 1000 μ F / 4V Low ESR tantalum Capacitor
ex.) Kemet: T530X108M4AE6(1000 μ F/4V)

Please make sure to place C1 and C2 nearby input and output terminal of DC-DC converter.

⚠ Note:

1. This datasheet is downloaded from the website of Murata Manufacturing co., ltd. Therefore, it's specifications are subject to change or our products in it may be discontinued without advance notice. Please check with our sales representatives or product engineers before ordering.
2. This datasheet has only typical specifications because there is no space for detailed specifications. Therefore, please approve our product specifications or transact the approval sheet for product specifications before ordering.

10.2. Ripple Noise Measurement Circuit

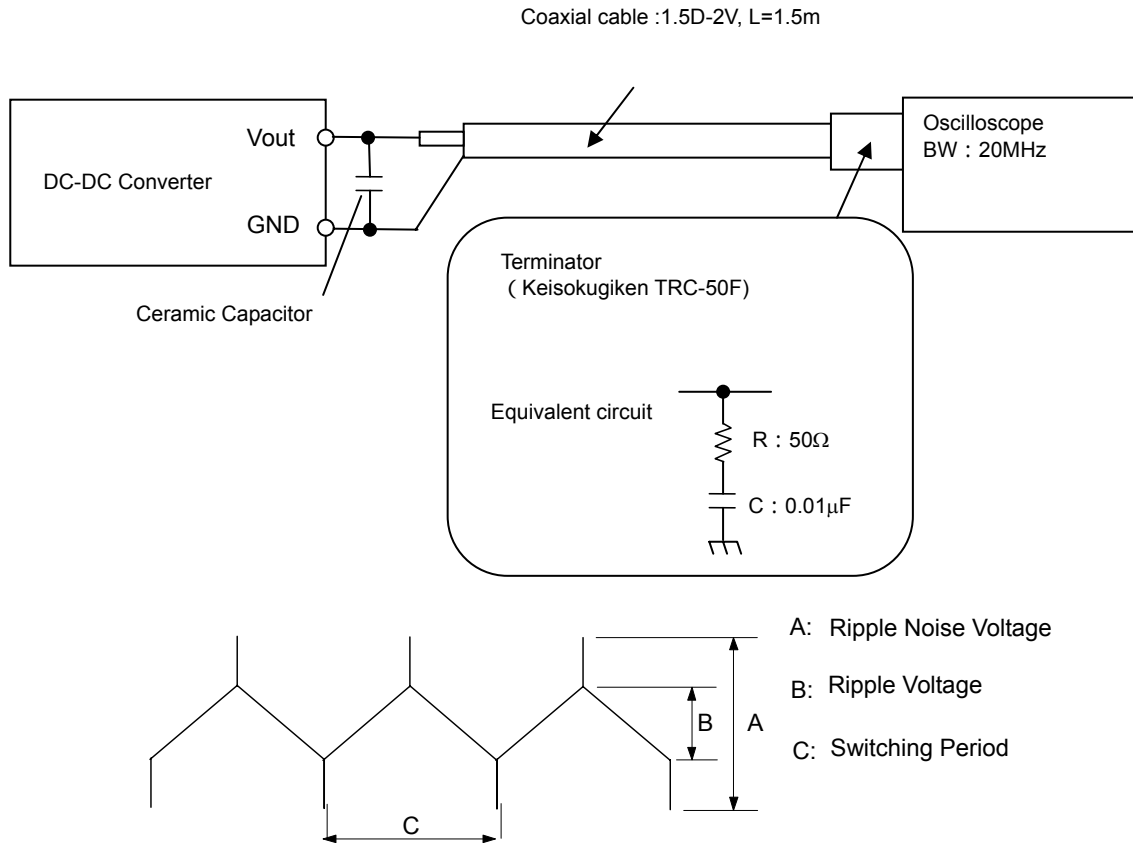

10.3. Land Ptttern Recommendation

Both input-side and output side, please make the wiring loop between plus and minus as small as possible. The influence of a leakage inductance can be reduced. Please separate GND(Vin) line from GND(Vout) line. The following figure is an example of recommended PCB design. Please make the power line pattern as wide and short as possible. The Following figure is an example of recommendable PCB design.

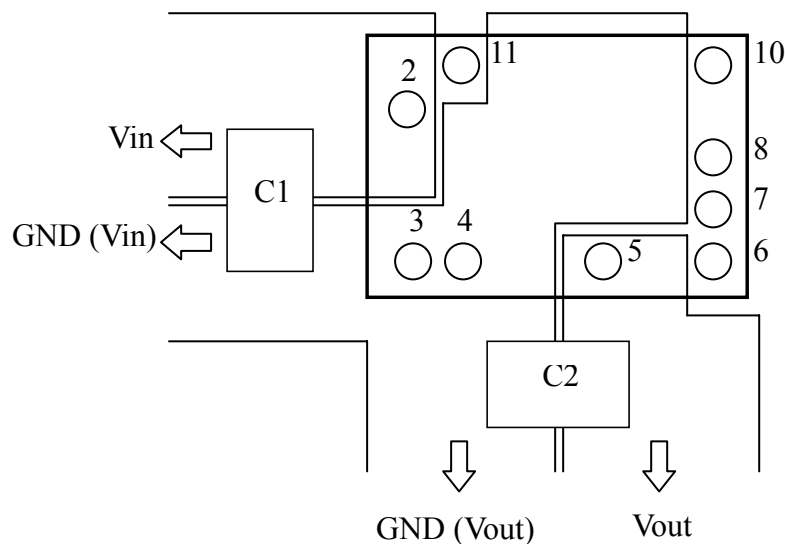

⚠ Note:

1. This datasheet is downloaded from the website of Murata Manufacturing co., ltd. Therefore, it's specifications are subject to change or our products in it may be discontinued without advance notice. Please check with our sales representatives or product engineers before ordering.
2. This datasheet has only typical specifications because there is no space for detailed specifications. Therefore, please approve our product specifications or transact the approval sheet for product specifications before ordering.

11. Packaging Specification

11.1. DC-DC converters are put in the trays. (see Fig.1)

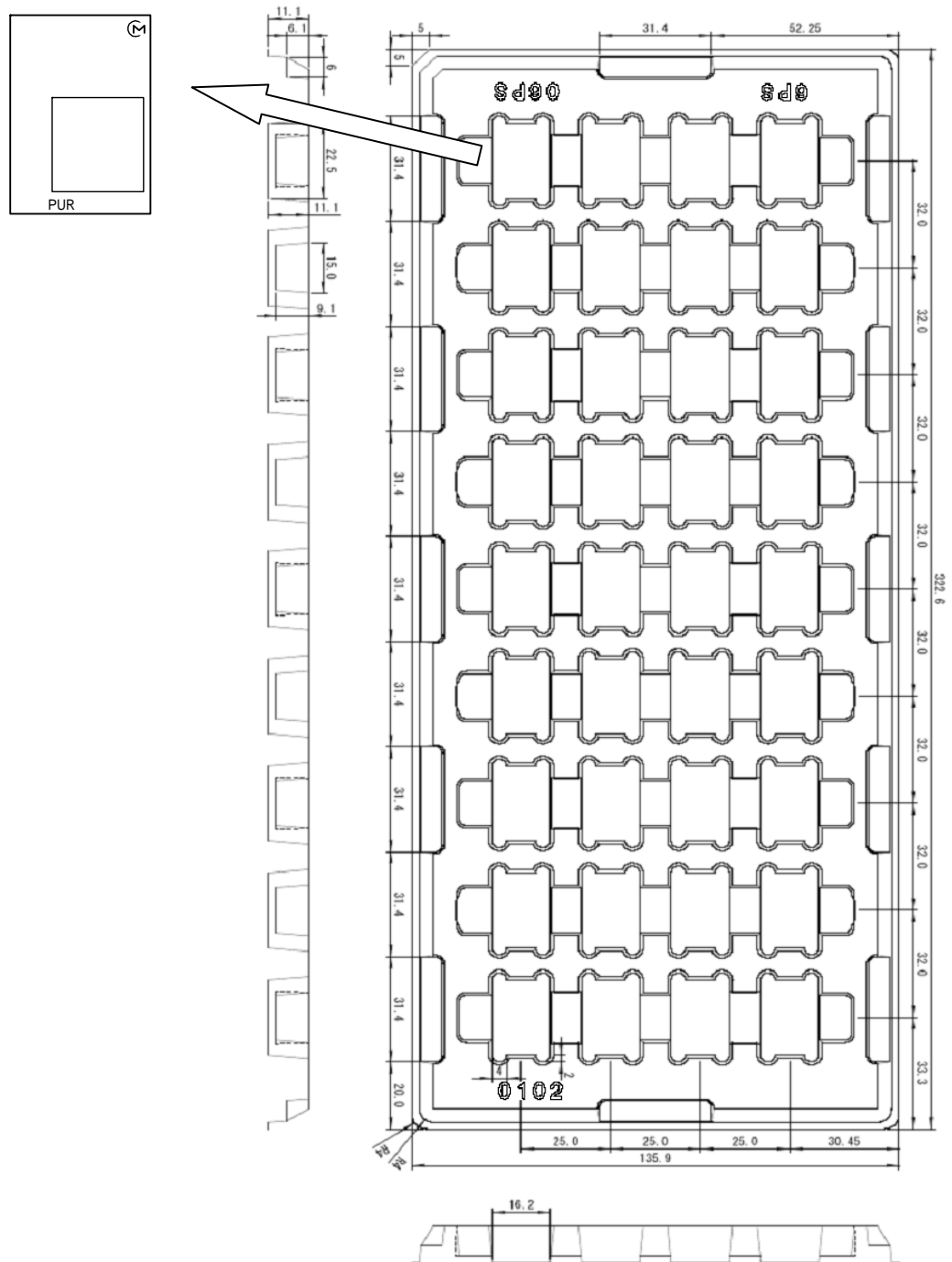

Fig.1

11.2. Contained pieces of products per corrugated box.

Maximum Contained products pieces 180 pcs/corrugated box.

Further plural sheets of corrugated cardboard are placed on the top of the dummy tray according to number of contained trays in order to full up the space in a corrugated box.

⚠ Note:

1. This datasheet is downloaded from the website of Murata Manufacturing co., ltd. Therefore, it's specifications are subject to change or our products in it may be discontinued without advance notice. Please check with our sales representatives or product engineers before ordering.
2. This datasheet has only typical specifications because there is no space for detailed specifications. Therefore, please approve our product specifications or transact the approval sheet for product specifications before ordering.

11.3. Packing Form

Trays with products are lidded and packed in a corrugated box. (See Fig.2)

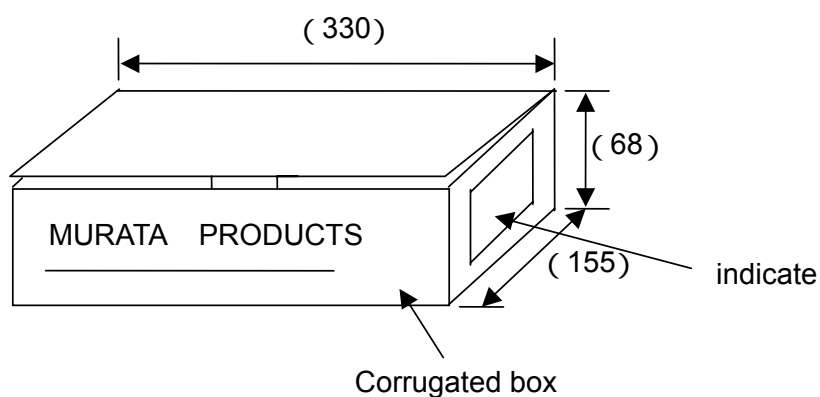
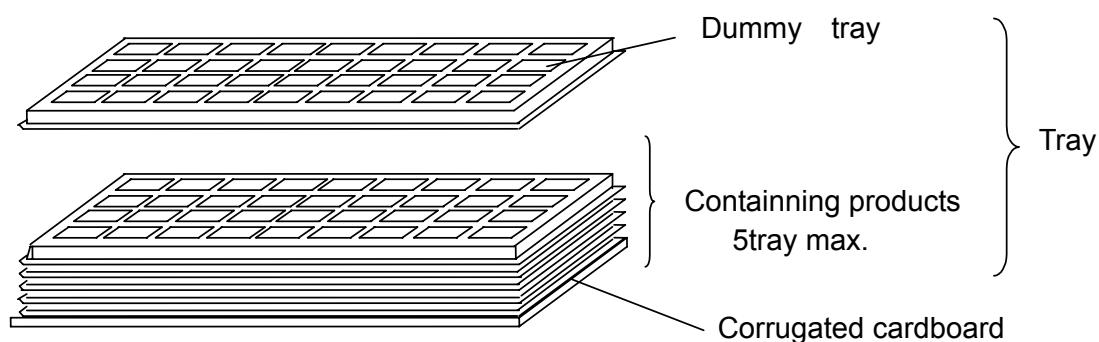

Fig.2

Corrugated box is reference only.

12. Production factory

Komatsu Murata Mfg.Co., Ltd.

Kanazu Murata Mfg. Co., Ltd.

Wakura Murata Mfg. Co., Ltd.

⚠ **Note:**

1. This datasheet is downloaded from the website of Murata Manufacturing co., ltd. Therefore, it's specifications are subject to change or our products in it may be discontinued without advance notice. Please check with our sales representatives or product engineers before ordering.
2. This datasheet has only typical specifications because there is no space for detailed specifications. Therefore, please approve our product specifications or transact the approval sheet for product specifications before ordering.

13.  Caution

1. Be sure to provide an appropriate fail-safe function on your product to prevent secondary damage that may be caused due to abnormal functional or failure of this product.
2. Inrush current protection is not a feature of this product.
3. Please connect the input terminals with the correct polarity. If an error in polarity connection is made this product may be damaged. If this product is damaged internally, an elevated input current may flow, and so this product may exhibit an abnormal temperature rise, or your product may be damaged. Please add a diode and fuse per the following diagram to protect them.

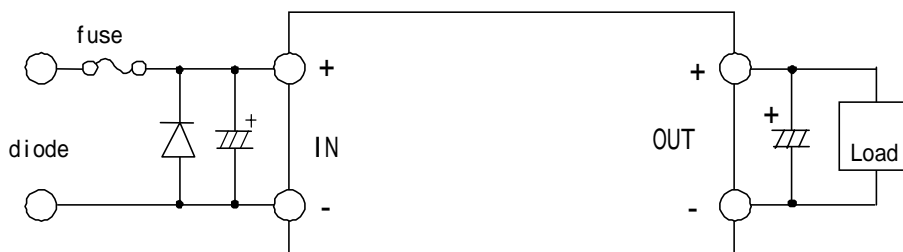

Please select diode and fuse after confirming the operation of your product.

4. Limitation of Application

Please contact us before using this product for the applications listed below which require especially high reliability for the prevention of defects, which might directly cause damage to the third party's life, body or property.

Aircraft equipment
 Aerospace equipment
 Undersea equipment
 Power plant control equipment
 Medical equipment
 Transportation equipment (vehicles, trains, ships, etc.)
 Traffic signal equipment
 Disaster prevention /crime prevention equipment
 Any other application of similar complexity and/or reliability requirements to the applications listed above.

14. Notice

14.1. Soldering

14.1.1. Flux

Please solder this product with Rosin Flux that contains of 0.2wt% or less chlorine.
 Please do not use high activity acid flux or water-soluble flux as they may reduce the reliability of this product.

 Note:

1. This datasheet is downloaded from the website of Murata Manufacturing co., ltd. Therefore, it's specifications are subject to change or our products in it may be discontinued without advance notice. Please check with our sales representatives or product engineers before ordering.
2. This datasheet has only typical specifications because there is no space for detailed specifications. Therefore, please approve our product specifications or transact the approval sheet for product specifications before ordering.

14.1.2. PCB Land Pattern Recommendation

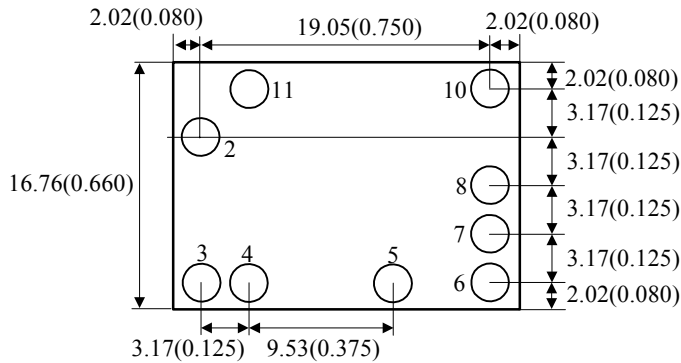

Recommended land size $\phi 2.16(0.085)$

14.1.3. Soldering Conditions Recommendation

Reflow Soldering

This product is RoHS compliant. The following profile is recommended for the reflow of this product using Pb-free solder paste (Sn-Ag-Cu).

Method : Full convection reflow soldering

Reflow Soldering Profile

JEDEC IPC/JEDEC J-STD-020D
Table 5-2 Classification Reflow Profile
Pb-Free Assembly Large Body

Profile details

Soldering temperature : 245°C+0/-5°C
Soldering time : 30 seconds, 240 to 245°C
Heating time : 60 to 150 seconds, over 217°C
Preheating time : 60 to 120 seconds, 150 to 200°C
Programming rate : 3°C/ sec. Max., 217 to 245°C
Descending rate : 6°C/ sec. Max.
Total soldering time : 8 minutes Max., 25 to 245°C
Times : 1 time

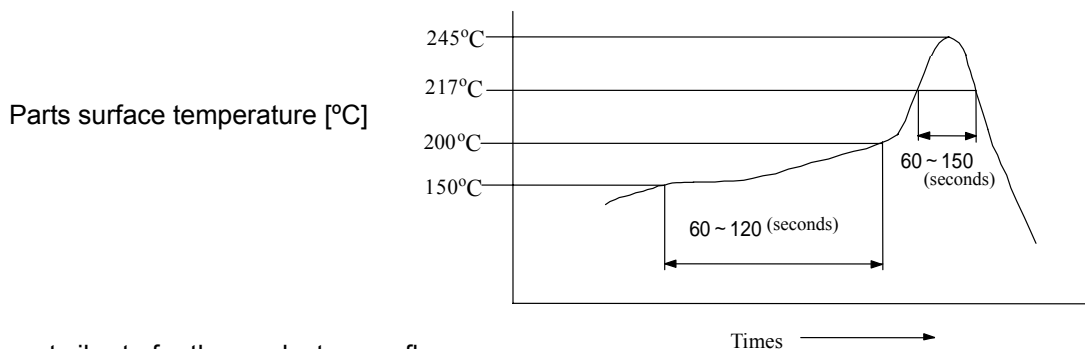

Do not vibrate for the products on reflow.

Please need to take care temperature control because mounted parts may come off if the product are left under the high temperature.

Do not reflow DC-DC converter as follows, because DC-DC converter may fall down from a substrate during reflowing.

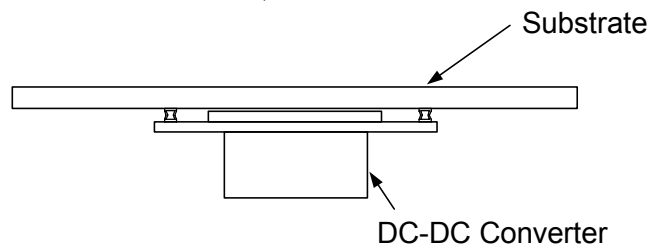

⚠ Note:

1. This datasheet is downloaded from the website of Murata Manufacturing co., ltd. Therefore, it's specifications are subject to change or our products in it may be discontinued without advance notice. Please check with our sales representatives or product engineers before ordering.
2. This datasheet has only typical specifications because there is no space for detailed specifications. Therefore, please approve our product specifications or transact the approval sheet for product specifications before ordering.

14. 2. Cleaning

Please use no-cleaning type flux and do not wash this product.

14.3. Storage

14.3.1. Please store the products in room where the temperature/humidity is stable and direct sunlight cannot come in, and use the products within 6 months after delivery.

Please avoid damp and heat or such places where the temperature greatly changes, as water may condense on this product, and the quality of characteristics may be reduced, and/or be the solderability may be degraded.

If this product needs to be stored for a long time (more than 1 year), this product may be degraded in solderability and/or corroded. Please test the solderability of this product regularly.

Baking before reflow process is unnecessary to store the products under 30 ± 5 °C, 60%RH or less up to 6 months.

In case the storage condition is over above mentioned, if these are unpacked condition, please bake them at 125 ± 5 °C /24hour. If these are packed in a tape, please bake them before soldering at 60 ± 5 °C /168hour.

14.3.2. Please do not store this product in places such as :

A dusty place, a place exposed directly to sea breeze, or in an atmosphere containing corrosive gas (Cl₂, NH₃, SO₂, NO_x and so on).

14. 4. Operational Environment and Operational Conditions

14.4.1. Operational Environment

This product is not water-, chemical- or corrosion-proof.

In order to prevent leakage of electricity and abnormal temperature rise of the product, do not operate under the following environmental conditions:

- (1) An atmosphere containing corrosive gas (Cl₂, NH₃, SO₂, NO_x and so on)
- (2) A high-dust environment
- (3) Under the exposure of direct sunlight
- (4) A location where the likelihood of exposure to water or water condensation exists.
- (5) A location exposed to ocean air
- (6) Any locations similar to the above

14.4.2. Operational Conditions

Please use this product within specified values (power supply, temperature, input, output and load condition, and so on). If the product is exposed to conditions outside of the specified values reliability of the product may be adversely effected.

14.4.3. Note prior to use

Diminished reliability and/ or failure may result if the product is exposed to a high-level static charge, over-rated voltage or reverse voltage. Please avoid the following conditions be avoided prior to use of the product:

- (1) Supply of power outside of rated values (see section 8)
- (2) Supply of reverse power or inadequate connection of a 0 V(DC)line
- (3) Electrostatic discharge from production line and/ or operator
- (4) Electrification of the product from electrostatic induction
- (5) Excessive mechanical shock

14.5. Transportation

Murata recommends that when transporting this product, it be packed so as to avoid damage by mechanical vibration or exposure to adverse conditions such as ocean air, high humidity. It is additionally recommended that appropriate instructions and guidelines be communicated to carriers to prevent exposure to these same conditions.

15. Note

1. Murata recommends that customers ensure that the evaluation and testing of these devices are completed with this product actually assembled on their product.
2. All the items and parameters in this product specification have been prescribed on the premise that Murata's product is used for the purpose, under the condition and in the environment mutually agreed upon.

**This document is for reference only and subject to revision without prior of subsequent notice.
Please contact Murata for latest documentation.**

Note:

1. This datasheet is downloaded from the website of Murata Manufacturing co., ltd. Therefore, it's specifications are subject to change or our products in it may be discontinued without advance notice. Please check with our sales representatives or product engineers before ordering.
2. This datasheet has only typical specifications because there is no space for detailed specifications. Therefore, please approve our product specifications or transact the approval sheet for product specifications before ordering.



Компания «ЭлектроПласт» предлагает заключение долгосрочных отношений при поставках импортных электронных компонентов на взаимовыгодных условиях!

Наши преимущества:

- Оперативные поставки широкого спектра электронных компонентов отечественного и импортного производства напрямую от производителей и с крупнейших мировых складов;
- Поставка более 17-ти миллионов наименований электронных компонентов;
- Поставка сложных, дефицитных, либо снятых с производства позиций;
- Оперативные сроки поставки под заказ (от 5 рабочих дней);
- Экспресс доставка в любую точку России;
- Техническая поддержка проекта, помощь в подборе аналогов, поставка прототипов;
- Система менеджмента качества сертифицирована по Международному стандарту ISO 9001;
- Лицензия ФСБ на осуществление работ с использованием сведений, составляющих государственную тайну;
- Поставка специализированных компонентов (Xilinx, Altera, Analog Devices, Intersil, Interpoint, Microsemi, Aeroflex, Peregrine, Syfer, Eurofarad, Texas Instrument, Miteq, Cobham, E2V, MA-COM, Hittite, Mini-Circuits, General Dynamics и др.);

Помимо этого, одним из направлений компании «ЭлектроПласт» является направление «Источники питания». Мы предлагаем Вам помощь Конструкторского отдела:

- Подбор оптимального решения, техническое обоснование при выборе компонента;
- Подбор аналогов;
- Консультации по применению компонента;
- Поставка образцов и прототипов;
- Техническая поддержка проекта;
- Защита от снятия компонента с производства.



Как с нами связаться

Телефон: 8 (812) 309 58 32 (многоканальный)

Факс: 8 (812) 320-02-42

Электронная почта: org@eplast1.ru

Адрес: 198099, г. Санкт-Петербург, ул. Калинина, дом 2, корпус 4, литера А.