



SGA8343Z

Heterostructure Bipolar Transistor

Product Overview

The Qorvo® SGA8343Z is a high-performance Silicon Germanium Heterostructure Bipolar Transistor (SiGe HBT) designed for operation from DC to 6GHz.

The SGA8343Z is optimized for 3V operation but can be biased at 2V for low-voltage battery operated systems. The device provides high gain, low NF, and excellent linearity at a low cost. It can be operated at very low bias currents in applications where high linearity is not required.

The matte tin finish on the lead-free package utilizes a post annealing process to mitigate tin whisker formation and is RoHS compliant per EU Directive 2002/95.

This package is also manufactured with green molding compounds that contain no antimony trioxide nor halogenated fire retardants.



4-Pin SOT-343 Package

Key Features

- DC – 6,000 MHz
- 0.9 dB Min Noise Figure at 900 MHz
- 24 dB Max Gain at 900 MHz
- 0.10 Γ_{OPT} at 900 MHz
- +28dBm OIP3 at +9 dBm P^{1dB}
- High performance and high versatility

Applications

- Analog and Digital Wireless Systems
- 3G, Cellular, PCS, RFID
- Fixed Wireless, Pager Systems
- Driver Stage for Low Power Applications
- Oscillators

Functional Block Diagram

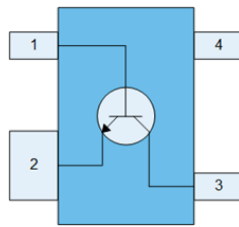

Top View

Ordering Information

Part Number	Description
SGA8343ZSQ	Sample bag with 25 pieces
SGA8343ZSR	7" reel with 100 pieces
SGA8343Z	7" reel with 3,000 pieces
SGA8343ZPCK1	0.8-1 GHz Assembled Evaluation Board with 5 pc bag
SGA8343ZPCK2	1.8-2 GHz Assembled Evaluation Board with 5 pc bag
SGA8343ZPCK3	2.4-2.5GHz Assembled Evaluation Board with 5 pc bag
SGA8343ZPCK4	1,575MHz Assembled Evaluation Board with 5 pc bag

Absolute Maximum Ratings

Parameter	Conditions	Rating
Collector Current (ICE)		72 mA
Base Current (IB)		1 mA
Collector – Emitter Voltage (VCE)		5 V
Collector – Base Voltage (VCB)		+12 V
Emitter – Base Voltage (VEB)		+4.5 V
RF Input Power at Pin 1		+5 dBm
Storage Temperature Range (TSOR)		-40 to 150 °C
Power Dissipation (PDISS)		350 mW
Operating Junction Temperature (TJ)		+150 °C
Operating Temperature Range		-40 to 85 °C

Exceeding any one or a combination of the Absolute Maximum Rating conditions may cause permanent damage to the device. Extended application of Absolute Maximum Rating conditions to the device may reduce device reliability. For reliable continuous operation, the device voltage and current must not exceed the maximum operating values specified in the table on page one.

Electrical Specifications

Parameter	Conditions	Min.	Typ.	Max.	Units
Transmit (BASE-COLLECTOR) Mode	Unless otherwise noted: V_{CC/DD}=3.3V, T=+25°C, PA_EN=High, LNA_EN=Low, C_RX=Low				
Maximum Available Gain	0.90GHz. Z _S =Z _S [*] , Z _L =Z _L [*]		23.9		dB
	1.90GHz		19.3		dB
	2.40GHz		17.7		dB
Minimum Noise Figure	0.90GHz. Z _S =Γ _{OPT} , Z _L =Z _L [*]		0.94		dB
	1.90GHz		1.10		dB
	2.40GHz		1.18		dB
Insertion Gain	0.90GHz. Z _S =Z _L =50Ω ⁽¹⁾	21.0	22.0	23.0	dB
Noise Figure	1.9GHz, LNA Application Circuit Board ⁽²⁾		1.40	1.75	dB
Gain	1.9GHz, LNA Application Circuit Board ⁽²⁾	15.5	16.5	17.5	mA
Output IP3	1.9GHz, LNA Application Circuit Board ⁽²⁾	+25.8	+27.8		dBm
Output 1dB Compression Point	1.9GHz, LNA Application Circuit Board ⁽²⁾	+7.5	+9.0		dBm
DC Current Gain		120	180	300	
Breakdown Voltage	COLLECTOR-EMITTER	+5.7	+6.0		V
Thermal Resistance, θ _{jc}	Junction - Lead		200		°C/W
Operating Voltage	COLLECTOR-EMITTER			+4.0	V
Operating Current	COLLECTOR-EMITTER			50	mA

Notes:

1. Performance is based on historical statistical analysis.
2. 100% tested on test fixture optimized for 1.9GHz operation.

Typical Performance – 3V, 10mA

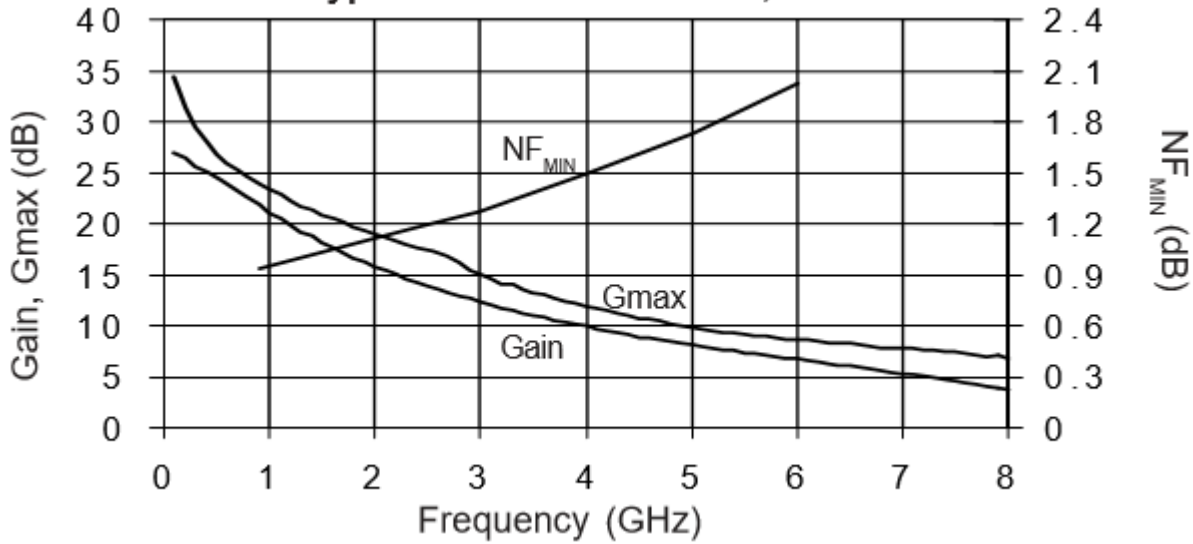

Notes:

Typical Performance – Engineering Application Circuits

Frequency (GHz)	VS (V)	VCE (V)	ICQ (mA)	NF (dB)	Gain (dB)	P1dB (dBm)	OIP3 ⁽¹⁾ (dBm)	S11 (dB)	S22 (dB)
0.90 ⁽²⁾	+3.0	+3.0	12	1.25	18.2	9	27.3	-16	-18
1.575 ⁽²⁾	+3.3	+2.7	10	1.25	15.7	6.8	26.5	-10	-25
1.9 ⁽²⁾	+5.0	+3.0	12	1.4	16.5	9	27.8	-9	-24
2.4	+3.3	+2.7	10	1.6	14.4	9	27.5	-13	-24

Notes:

1. P_{OUT}=0dBm per tone, 1MHz tone spacing.
2. Series feedback
3. Refer to the application note for additional RF data, PCB layouts, BOMs, biasing instructions, and other key issues to be considered.

Peak Performance Under Optimum Matching Conditions

Frequency (GHz)	VCE (V)	ICQ (mA)	NF (dB)	Max Gain (dB)	P1dB (dBm)	OIP3 ⁽¹⁾ (dBm)
0.90	+2	10	0.90	23.7	10	+25
0.90	+3	10	0.94	23.9	13	+29
1.90	+2	10	1.05	19.1	10	+25
1.90	+3	10	1.10	19.3	13	+29
2.40	+2	10	1.15	17.4	10	+25
2.40	+3	10	1.18	17.7	13	+29

Notes:

4. Z_S=Γ_{OPT}, Z_L=Z_L^{*}, The input matching circuit loss have been de-embedded
5. Z_S=Z_{SOPT}, Z_L=Z_{LOPT}, where Z_{SOPT} and Z_{LOPT} have been tuned for max P1dB (current allowed to drive-up with constant VCE).series feedback
6. Z_S=Z_{SOPT}, Z_L=Z_{LOPT}, where Z_{SOPT} and Z_{LOPT} have been tuned for max OIP3.
7. Optimum NF, P1dB, and OIP3 performance cannot be achieved simultaneously.

Typical Performance – De-embedded S-Parameters

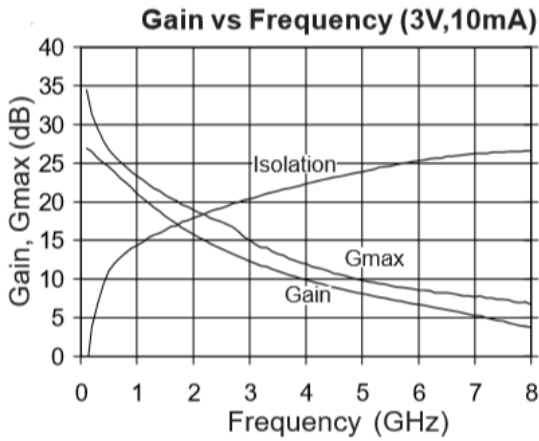

S11 versus Frequency

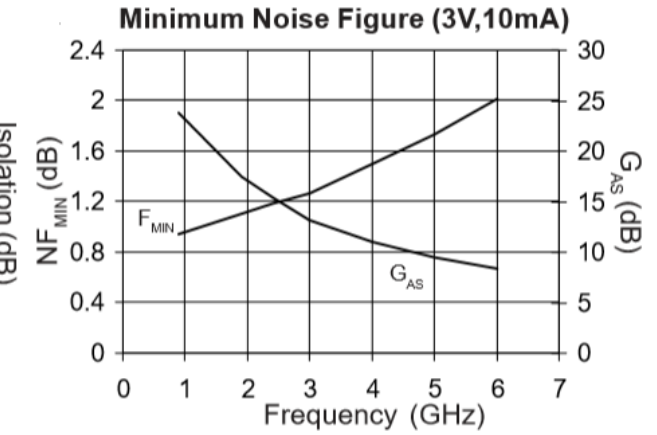

S22 versus Frequency

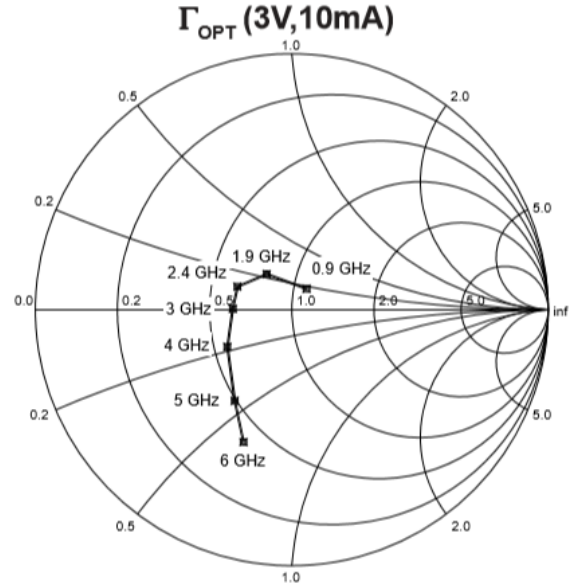
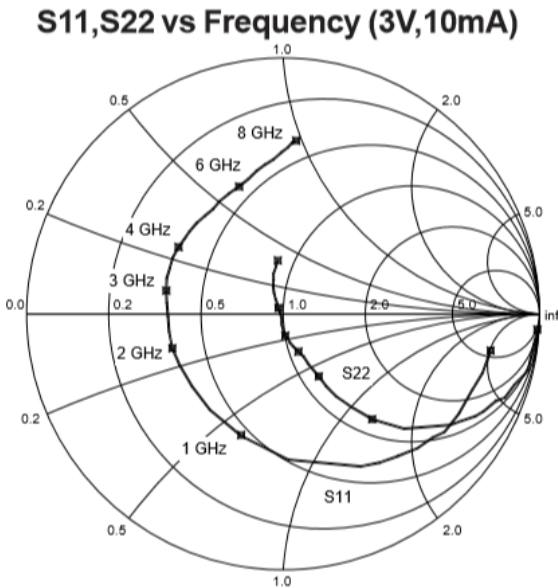

Notes:

S-parameters are de-embedded to the device leads with Z_S=Z_L=50Ω. De-embedded S-parameters can be downloaded from our website (www.qorvo.com).

Peak Performance Under Optimum Matching Conditions

Frequency (GHz)	Min NF ⁽⁸⁾ (dB)	Γ_{OPT} (Mag<Ang)	r_n (Ω)	Max Gain (dB)
0.9	0.94	0.10<55	0.11	23.88
1.9	1.10	0.71<125	0.10	19.33
2.4	1.18	0.25<157	0.09	17.66
3	1.27	0.23<179	0.09	15.01
4	1.50	0.29<-150	0.12	11.94
5	1.73	0.42<-122	0.18	9.84
6	2.02	0.55<-110	0.24	8.62

Notes:

8. $Z_S = \Gamma_{OPT}$, $Z_L = Z_L^*$, NFMIN is a noise parameter for which the input matching circuit losses have been de-embedded. The noise parameters were measured using a Maury Microwave Automated Tuner System. The device was mounted on a 0.010" PCB with plated-thru holes close to pins 2 and 4.

EVB1 800-1000 MHz Evaluation Board Schematic and Layout

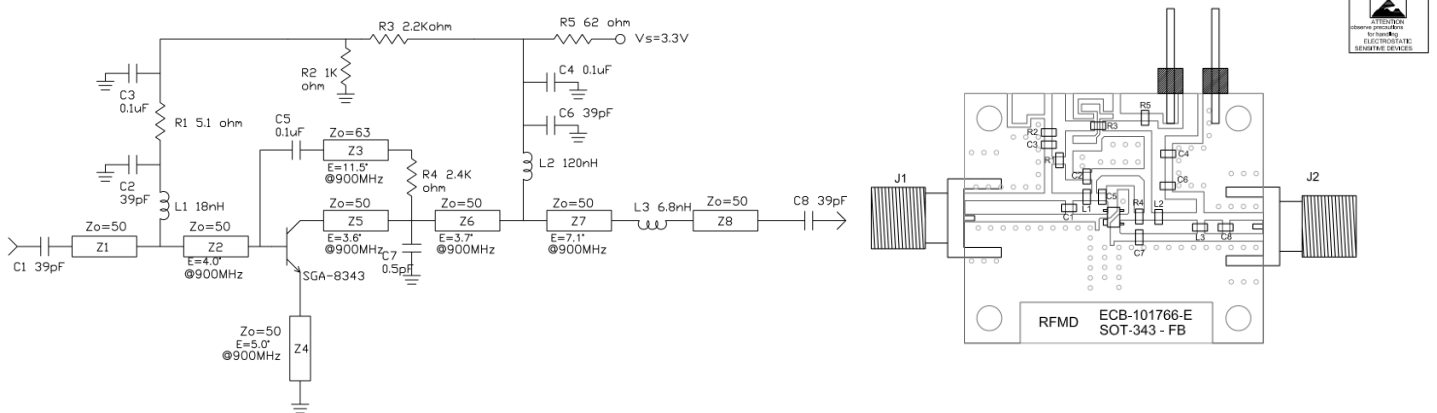

Notes:

Bill of Material

Ref. Des.	Value	Description	Manuf.	Part number
-	-	Printed Circuit Board		
U1	-	Low Noise, High Gain HBT	Qorvo	SGA8343Z
R1	5.1 Ω	Resistor, Chip, 5%, 1/16W, 0603	Panasonic	ERJ-3GEYJ5R1
R2	1,000 Ω	Resistor, Chip, 5%, 1/16W, 0603	Panasonic	ERJ-3GEYJ102
R3	2,200 Ω	Resistor, Chip, 5%, 1/16W, 0603	Panasonic	ERJ-3GEYJ222
R4	2,400 Ω	Resistor, Chip, 5%, 1/16W, 0603	Panasonic	ERJ-3GEYJ242
R5	62 Ω	Resistor, Chip, 5%, 1/16W, 0603	Panasonic	ERJ-3GEYJ620
C1, C2, C6, C8	39 pF	Capacitor, Chip, 0603	Johanson	500R14N390JV4T
C3, C4, C5	0.1 μF	Capacitor, Chip, 10%, 16V, X7R, 0603	Murata	GRM188R71C104KA01D
C7	0.5 pF	Capacitor, Chip, +/-0.25pF, 50V, C0G, 0603	Panasonic	ECJ-1VC1H0R5C
L1	18 nH	Inductor, Chip, 5%, M/L 0603	Toko America	LL1608-FSL18NJ
L2	120 nH	Inductor, Chip, 5%, M/L 0603	Toko America	LL1608-FSR12J
L3	6.8 nH	Inductor, Chip, 5%, M/L 0603	Toko America	LL1608-FSL6N8J
-	-	Do Not Install		

EVB2 1800-2000 MHz Evaluation Board Schematic and Layout

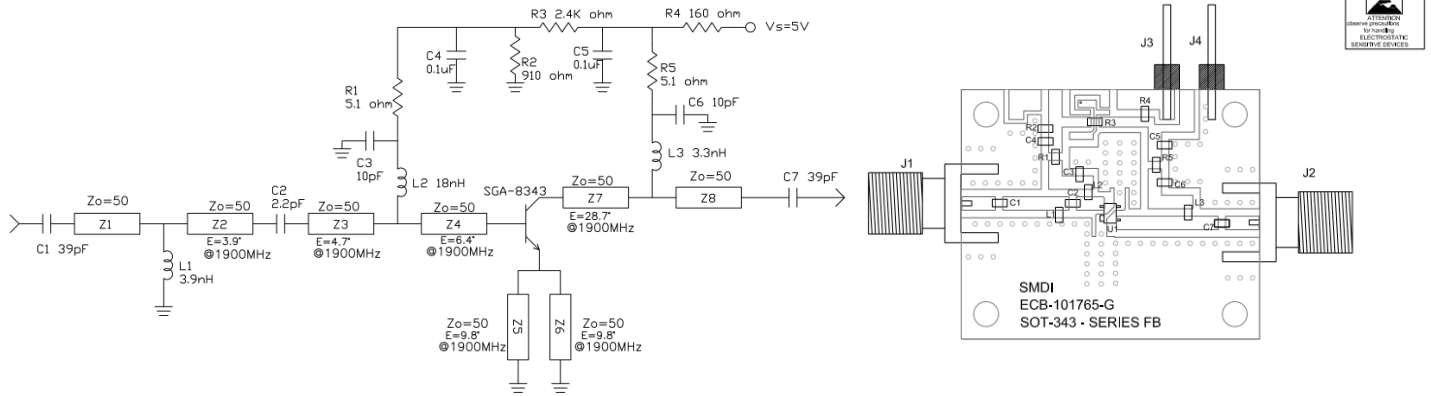

Notes:

Bill of Material

Ref. Des.	Value	Description	Manuf.	Part number
-	-	Printed Circuit Board		
U1	-	Low Noise, High Gain HBT	Qorvo	SGA8343Z
R1, R5	5.1 Ω	Resistor, Chip, 5%, 1/16W, 0603	Panasonic	ERJ-3GEYJ5R1
R2	910 Ω	Resistor, Chip, 5%, 1/16W, 0603	Panasonic	ERJ-3GEYJ911
R3	2,400 Ω	Resistor, Chip, 5%, 1/16W, 0603	Panasonic	ERJ-3GEYJ242
R4	160 Ω	Resistor, Chip, 5%, 1/16W, 0603	Panasonic	ERJ-3GEYJ161
C1, C7	39 pF	Capacitor, Chip, 0603	Johanson	500R14N390JV4T
C2	2.2 pF	Capacitor, Chip, +/-0.25pF, 50V, C0G, 0603	Murata	GRP1885C1H2R2CZ01D
C3, C6	10 pF	Capacitor, Chip, 5%, 50V, C0G, 0603	Johanson	500R14N100JV4
C4, C5	0.1 μF	Capacitor, Chip, 10%, 16V, X7R, 0603	Murata	GRM188R71C104KA01D
L1	3.9 nH	Inductor, Chip, +/-0.3nH, M/L 0603	Toko America	LL1608-FS3N9S
L2	18 nH	Inductor, Chip, 5%, M/L 0603	Toko America	LL1608-FSL18NJ
L3	3.3 nH	Inductor, Chip, +/-0.3nH, M/L 0603	Toko America	LL1608-FSL3N3S
-	-	Do Not Install		

EVB3 2.4-2.5 GHz Evaluation Board Schematic and Layout

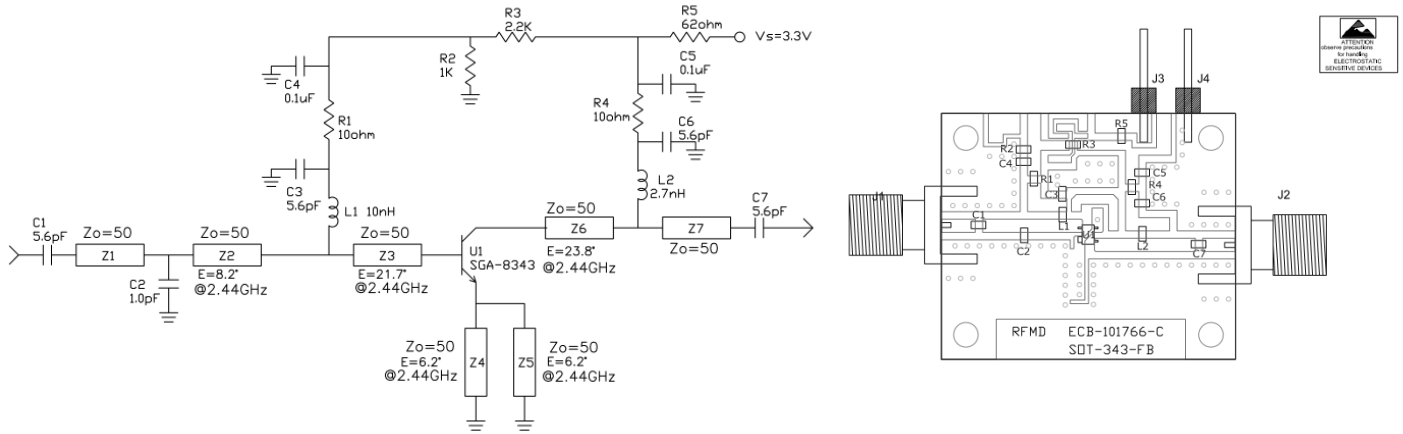

Notes:

Bill of Material

Ref. Des.	Value	Description	Manuf.	Part number
-	-	Printed Circuit Board		
U1	-	Low Noise, High Gain HBT	Qorvo	SGA8343Z
R1, R4	10 Ω	Resistor, Chip, 5%, 1/16W, 0603	Panasonic	ERJ-3GEYJ100
R2	1,000 Ω	Resistor, Chip, 5%, 1/16W, 0603	Panasonic	ERJ-3GEYJ102
R3	2,200 Ω	Resistor, Chip, 5%, 1/16W, 0603	Panasonic	ERJ-3GEYJ222
R5	62 Ω	Resistor, Chip, 5%, 1/16W, 0603	Panasonic	ERJ-3GEYJ620
C1, C3, C6, C7	5.6 pF	Capacitor, Chip, +/-0.25pF, 50V, C0G, 0603	Murata	GRM1885C1H5R6CZ01D
C4, C5	0.1 μF	Capacitor, Chip, 10%, 16V, X7R, 0603	Murata	GRM188R71C104KA01D
C2	1 pF	Capacitor, Chip, +/-0.25pF, 50V, C0G, 0603	Murata	GRM1885C1H1R0CZ01D
L1	10 nH	Inductor, Chip, 5%, M/L 0603	Toko America	LL1608-FSL18NJ
L2	2.7 nH	Inductor, Chip, +/-0.3nH, M/L 0603	Toko America	LL1608-FSL2N7S
-	-	Do Not Install		

EVB4 1575 MHz Evaluation Board Schematic and Layout

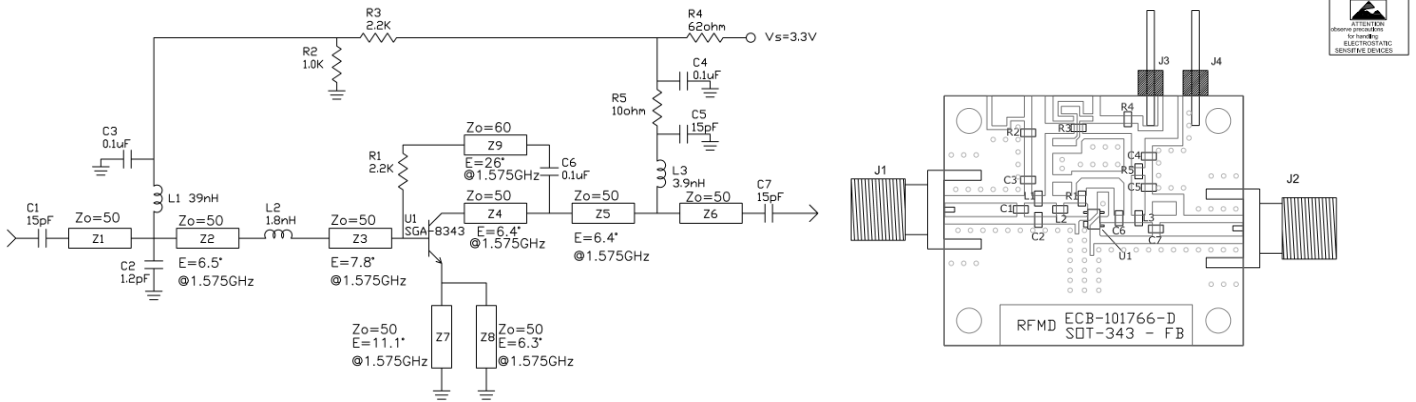

Notes:

Bill of Material

Ref. Des.	Value	Description	Manuf.	Part number
-	-	Printed Circuit Board		
U1	-	Low Noise, High Gain HBT	Qorvo	SGA8343Z
R5	10 Ω	Resistor, Chip, 5%, 1/16W, 0603	Panasonic	ERJ-3GEYJ100
R4	62 Ω	Resistor, Chip, 5%, 1/16W, 0603	Panasonic	ERJ-3GEYJ620
R2	1,000 Ω	Resistor, Chip, 5%, 1/16W, 0603	Panasonic	ERJ-3GEYJ102
R1, R3	2,200 Ω	Resistor, Chip, 5%, 1/16W, 0603	Panasonic	ERJ-3GEYJ222
C2	1.2 pF	Capacitor, Chip, +/-0.25pF, 50V, C0G, 0603	Venkel	C0603C0G500-1R2CNE
C1, C5, C7	15 pF	Capacitor, Chip, 5%, 50V, C0G, 0603	Panasonic	ECJ-1VC1H150J
C3, C4, C6	0.1 μF	Capacitor, Chip, 10%, 16V, X7R, 0603	Murata	GRM188R71C104KA01D
L1	39 nH	Inductor, Chip, 5%, M/L 0603	Toko America	LL1608-FSL39NJ
L2	1.8 nH	Inductor, Chip, +/-0.3nH, M/L 0603	Toko America	LL1608-FSL1N8K
L3	3.9 nH	Inductor, Chip, +/-0.3nH, M/L 0603	Toko America	LL1608-FS3N9S
-	-	Do Not Install		

Pin Configuration and Description

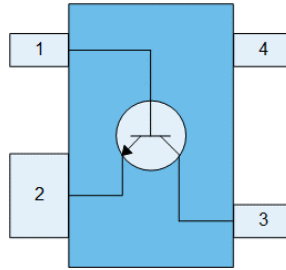

Top View

Pin Number	Label	Description
1	BASE	RF input/base pin.
2	EMITTER	Connection to ground. Use multiple via holes to reduce emitter inductance.
3	COLLECTOR	RF output/collector bias.
4	EMITTER	Connection to ground. Use multiple via holes to reduce emitter inductance.

Notes:

Mechanical Information

Dimensions and PCB Mounting Pattern

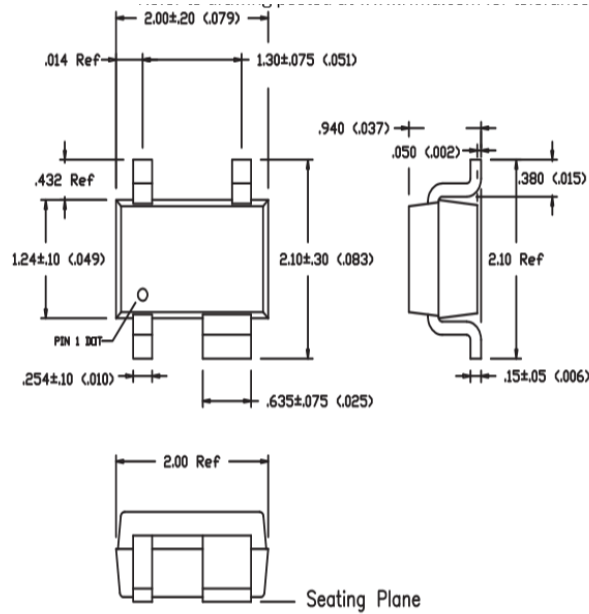

Scale (mm) 1:2

Recommended PCB Layout

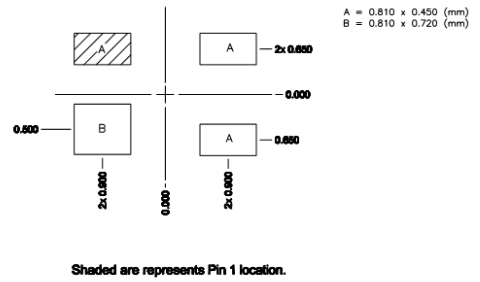
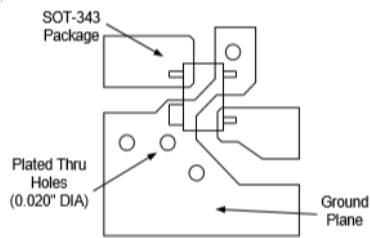

Figure 2. Stencil Recommendation

- Notes:
- All dimensions are in millimeters. Angles are in degrees.
 - Dimension and tolerance formats conform to ASME Y14.4M-1994.
 - The terminal #1 identifier and terminal numbering conform to JESD 95-1SPP-012
 - Use multiple plated-thru via holes located close to the package pins to ensure a good RF ground connection to a continuous ground plane on the backside of the board.

Handling Precautions

Parameter	Rating	Standard
ESD – Human Body Model (HBM)	Class 1A	JESD22-A114
ESD – Charged Device Model (CDM)	Class TBD	ANSI/ESD/JEDEC JS-002
MSL – Moisture Sensitivity Level	Level 1	IPC/JEDEC J-STD-020



Caution!
ESD sensitive device

Solderability

Compatible with both lead-free (260 °C max. reflow temperature) and tin/lead (245 °C max. reflow temperature) soldering processes.

Package lead metal: Cu lin 194

Package lead finish: 100% Matte Sn – 0.010 (0.0004) min thk

RoHS Compliance

This part is compliant with the 2011/65/EU RoHS directive (Restrictions on the Use of Certain Hazardous Substances in Electrical and Electronic Equipment), as amended by Directive 2015/863/EU.

This product also has the following attributes:

- Lead free
- Halogen Free (Chlorine, Bromine)
- Antimony Free
- TBBP-A (C₁₅H₁₂Br₄O₂) Free
- SVHC Free



Contact Information

For the latest specifications, additional product information, worldwide sales and distribution locations:

Web: www.qorvo.com

Tel: 1-844-890-8163

Email: customer.support@qorvo.com

Important Notice

The information contained herein is believed to be reliable; however, Qorvo makes no warranties regarding the information contained herein and assumes no responsibility or liability whatsoever for the use of the information contained herein. All information contained herein is subject to change without notice. Customers should obtain and verify the latest relevant information before placing orders for Qorvo products. The information contained herein or any use of such information does not grant, explicitly or implicitly, to any party any patent rights, licenses, or any other intellectual property rights, whether with regard to such information itself or anything described by such information. **THIS INFORMATION DOES NOT CONSTITUTE A WARRANTY WITH RESPECT TO THE PRODUCTS DESCRIBED HEREIN, AND QORVO HEREBY DISCLAIMS ANY AND ALL WARRANTIES WITH RESPECT TO SUCH PRODUCTS WHETHER EXPRESS OR IMPLIED BY LAW, COURSE OF DEALING, COURSE OF PERFORMANCE, USAGE OF TRADE OR OTHERWISE, INCLUDING THE IMPLIED WARRANTIES OF MERCHANTABILITY AND FITNESS FOR A PARTICULAR PURPOSE.**

Without limiting the generality of the foregoing, Qorvo products are not warranted or authorized for use as critical components in medical, life-saving, or life-sustaining applications, or other applications where a failure would reasonably be expected to cause severe personal injury or death.

Copyright 2020 © Qorvo, Inc. | Qorvo is a registered trademark of Qorvo, Inc.



Компания «ЭлектроПласт» предлагает заключение долгосрочных отношений при поставках импортных электронных компонентов на взаимовыгодных условиях!

Наши преимущества:

- Оперативные поставки широкого спектра электронных компонентов отечественного и импортного производства напрямую от производителей и с крупнейших мировых складов;
- Поставка более 17-ти миллионов наименований электронных компонентов;
- Поставка сложных, дефицитных, либо снятых с производства позиций;
- Оперативные сроки поставки под заказ (от 5 рабочих дней);
- Экспресс доставка в любую точку России;
- Техническая поддержка проекта, помощь в подборе аналогов, поставка прототипов;
- Система менеджмента качества сертифицирована по Международному стандарту ISO 9001;
- Лицензия ФСБ на осуществление работ с использованием сведений, составляющих государственную тайну;
- Поставка специализированных компонентов (Xilinx, Altera, Analog Devices, Intersil, Interpoint, Microsemi, Aeroflex, Peregrine, Syfer, Eurofarad, Texas Instrument, Miteq, Cobham, E2V, MA-COM, Hittite, Mini-Circuits, General Dynamics и др.);

Помимо этого, одним из направлений компании «ЭлектроПласт» является направление «Источники питания». Мы предлагаем Вам помощь Конструкторского отдела:

- Подбор оптимального решения, техническое обоснование при выборе компонента;
- Подбор аналогов;
- Консультации по применению компонента;
- Поставка образцов и прототипов;
- Техническая поддержка проекта;
- Защита от снятия компонента с производства.



Как с нами связаться

Телефон: 8 (812) 309 58 32 (многоканальный)

Факс: 8 (812) 320-02-42

Электронная почта: org@eplast1.ru

Адрес: 198099, г. Санкт-Петербург, ул. Калинина, дом 2, корпус 4, литера А.