

LPQ170 Series

175 Watts

Data Sheet

Total Power: 110 - 175 Watts
Input Voltage: 85 - 264 Vac
120 - 300 Vdc
of Outputs: Quad

SPECIAL FEATURES

- Active power factor correction
- IEC EN61000-3-2 compliance
- Adjustable outputs on 1, 3 & 4
Remote sense on main output
- Single wire current sharing
- Power fail and remote inhibit
- Built-in EMI filter
- Low output ripple
- Overvoltage protection
- Overload protection
- Thermal overload protection
- DC power good
- 5 V standby output
- Adjustable floating 4th output
- Optional cover (-C suffix)
- RoHS compliant

SAFETY

- UL UL60950
- CB Certificate and report
- CSA CSA 22.2-234 Level 3
- CE Mark (LVD)
- NEMKO EN 60950/EMKO-TUE

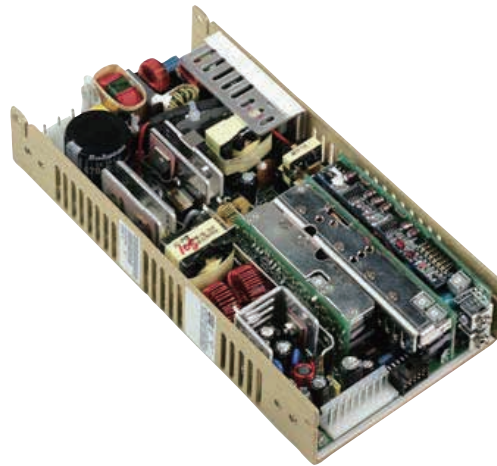

Electrical Specifications

Input	
Input range	85-264 Vac; 120-300 Vdc
Frequency	47-67 Hz
Inrush current	38 A max, cold start @ 25°C
Efficiency	75% typical at full load
EMI filter	Meets FCC Class B conducted CISPR 22 Class B conducted EN55022 Class B conducted VDE 0878 PT3 Class B conducted
Power factor	0.99 typical
Safety ground leakage current	1.0 mA @ 50/60 Hz, 264 Vac input
Output	
Maximum power	110 W convection (75 W with cover) 85 W convection - LPQ173 175 W with 30 CFM forced air (130 W with cover - LPQ172)
Adjustment range	3.3 - 5.5V on main; -12 - 15V on 3rd output 3.3 - 25 V on 4th output - LPQ172 3.3 - 5.5 V on 4th output - LPQ173
Hold-up time	20 ms @175 W load at nominal line
Overload protection	Short circuit protection on all outputs. Case overload protected @ 110-145% above peak rating
Overvoltage protection	Tracks outputs 1, 3 & 4; 15 to 35%
Standby output	5 V @ 200 mA regulated ±5%

Logic Control	
AC power failure	TTL logic signal goes high 100 - 500 msec after V1 output; It goes low at least 4 msec before loss of regulation
Remote sense	Compensates for 0.5 V lead drop min. Will operate without remote sense connected. Reverse connection protected.
DC - OK	TTL logic signal goes high after main output is in regulation. It goes low when there is a loss of regulation.

Environmental Specifications	
Operating temperature	0 °C to 50 °C ambient. Derate each output 2.5% per degree from 50 °C to 70 °C (except for -C version).
Storage temperature	-40 °C to +85 °C
Temperature coefficient	±0.4% per °C
Electromagnetic susceptibility	Designed to meet IE61000-4, -2, -3, -4, -5, -6, -8, -11, Level 3
Humidity	Operating; non-condensing 5% to 95%
Vibration	Three orthogonal axes, sweep at 1 oct/min, 5 min. dwell at four major resonances 0.75 G peak 5 Hz to 500 Hz, operational
MTBF demonstrated	>550,000 hours at full load and 25°C ambient conditions

Ordering Information							
Model Number	Output Voltage	Minimum Load	Maximum Load with Convection Cooling	Maximum Load with 30CFM Forced Air	Peak Load ¹	Regulation ²	Ripple P/P(PARD) ³
LPQ172	5 V (3.3 - 5.5 V)	0 A	15 A	30 A	32 A	±2%	50 mV
	12 V	0 A	6 A	8 A	10 A	±3%	120 mV
	-12 V (-12 -15 V)	0 A	1.5 A	3 A	3.5 A	±3%	<1%
	±3.3-25 V	0.5 A*	2 A	5 A	5.5 A	±3%	<50mV or 1%
LPQ173	5 V (3.3 - 5.5 V)	0 A	10 A	24 A	26 A	±2%	50 mV
	12 V	0 A	6 A	8 A	10 A	±3%	120 mV
	-12V (-12 -15 V)	0 A	.2 A	3 A	3.5 A	±3%	<1%
	5 V (3.3 - 5.5 V)	0 A	10 A	24 A	26 A	±2%	50 mV

1. Peak current lasting <30 seconds with a maximum 10% duty cycle.
2. At 25 °C including initial tolerance, line voltage, load currents and output voltages adjusted to factory settings.
3. Peak-to-peak with 20 MHz bandwidth and 10 µF in parallel with a 0.1 µF capacitor at rated line voltage and load ranges.
4. 4th output adjustable 3.3 - 25 V factory set at 5 V.
5. *Minimum loads are required when output set below 5 Volts
6. Remote inhibit resets OVP latch
7. LPQ173-C has no convection rating.
8. This product is a Component Power Supply and is only for inclusion by professional installers within other equipment and must not be operated as a standalone product. EMC compliance to appropriate standards must be verified at the system level. This product is for sale to OEMs and System Integrators, including through Distribution Channels. It is not intended for sale to End Users.

Note: -C suffix added to the model number indicates cover option and is limited to 50 °C operation.

Mechanical Drawing

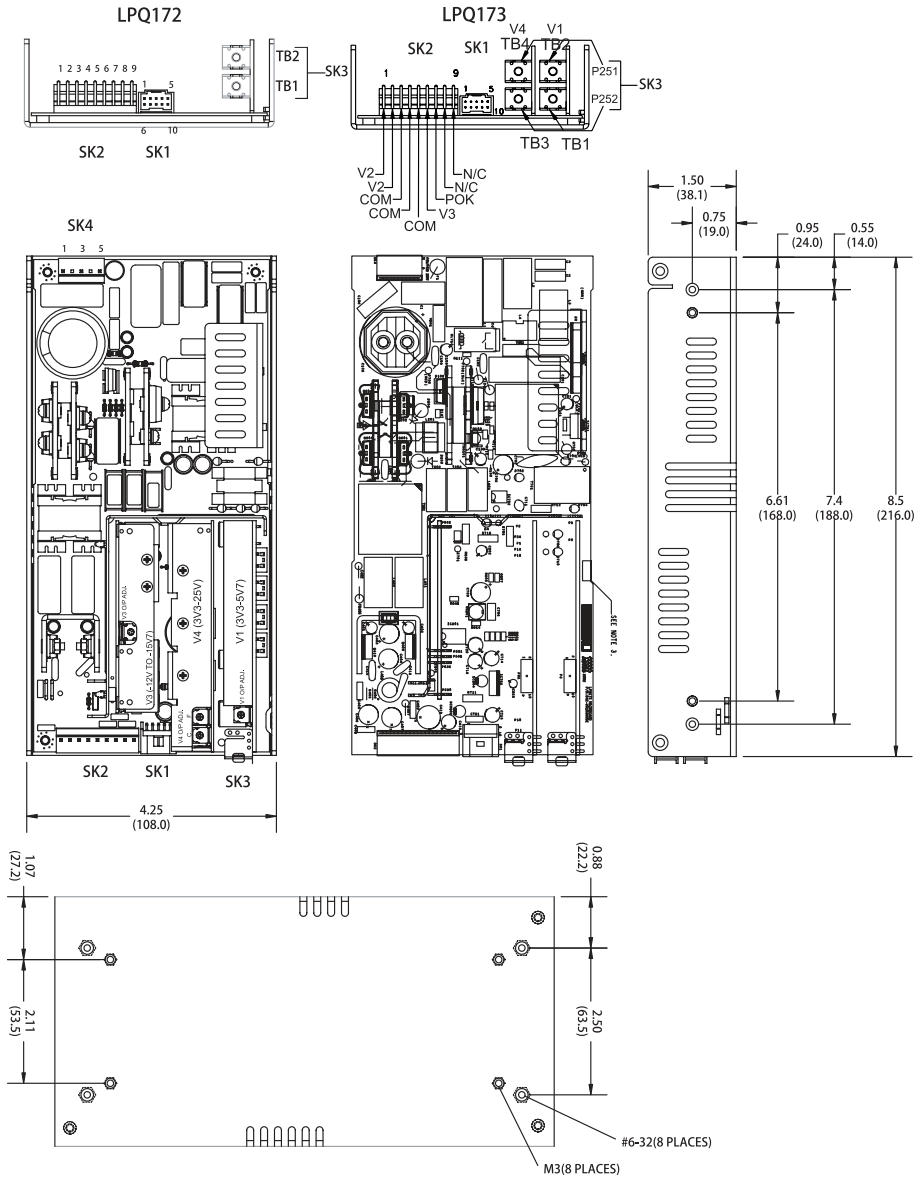

Notes:

1. Specifications subject to change without notice.
2. All dimensions in inches (mm), tolerance is ± 0.02 ".
3. Specifications are for convection rating at factory settings unless otherwise stated.
4. Mounting screw maximum insertion depth is 0.12".
5. Warranty: 2 years
6. Weight: 2 lb/0.91 kg

Pin Assignments			
Connector		LPQ172	LPQ173
SK1	PIN 1	N/C	V4 SWP
	PIN 2	5V Standby	5 V Standby
	PIN 3	N/C	+V4 Sense
	PIN 4	V1 SWP	V1 SWP
	PIN 5	Common	Common
	PIN 6	+V1 sense	+V1 sense
	PIN 7	Sense common	Sense common
	PIN 8	Remote inhibit	Remote inhibit
	PIN 9	DC power good	DC power good
	PIN 10	POK	POK
SK2	PIN 1,2	+12 V	+12V
	PIN 3,4,5	Common	Common
	PIN 6	-12 V	-12V
	PIN 7	POK	POK
	PIN 8	+3.3 V to +25 V (Float)	N/C
	PIN 9	Common (Float)	N/C
SK3	TB-1, 3	COMMON	COMMON
	TB-2	+5 V (3.3V to 5.5V)	+5V (3.3V to 5.5V)
	TB-4	N/C	+5V (3.3V to 5.5V)
SK4	PIN 1	GROUND	GROUND
	PIN 3	LINE	LINE
	PIN 5	NEUTRAL	NEUTRAL

Mating Connectors	
(SK4) AC Input	Molex 09-50-8051 (USA) Molex 09-91-0500 (UK) PINS: 08-58-0111
(SK3) Main output	Molex series 19141-0058/0063
(SK2) Aux DC Output/Power fail	Molex 09-50-8091 (USA) Molex 09-91-0900 (UK) PINS: 08-58-0111
(SK1) Control Signals	Molex 90142-0010 (USA) PINS: 90119-2110 or Amp: 87977-3 PINS: 87309-8
Astec connector kit #70-841-015, includes all of above	

WORLDWIDE OFFICES

Americas

2900 South Diablo Way
Suite B100
Tempe, AZ 85282, USA
+1 888 412 7832

Europe (UK)

Ground Floor Offices, Barbary House
4 Harbour Buildings, Waterfront West
Brierley Hill, West Midlands
DY5 1LN, UK
+44 (0) 1384 842 211

Asia (HK)

14/F, Lu Plaza
2 Wing Yip Street
Kwun Tong, Kowloon
Hong Kong
+852 2176 3333



www.artesyn.com

Artesyn Embedded Technologies, Artesyn Embedded Power, Artesyn, and all Artesyn related logos are trademarks and service marks of Artesyn Embedded Technologies, Inc. All other names and logos referred to are trade names, trademarks, or registered trademarks of their respective owners. Specifications are subject to change without notice. © 2019 Artesyn Embedded Technologies, Inc. All rights reserved. For full legal terms and conditions, please visit www.artesyn.com/legal.

For more information: www.artesyn.com
For support: productsupport.ep@artesyn.com



Компания «ЭлектроПласт» предлагает заключение долгосрочных отношений при поставках импортных электронных компонентов на взаимовыгодных условиях!

Наши преимущества:

- Оперативные поставки широкого спектра электронных компонентов отечественного и импортного производства напрямую от производителей и с крупнейших мировых складов;
- Поставка более 17-ти миллионов наименований электронных компонентов;
- Поставка сложных, дефицитных, либо снятых с производства позиций;
- Оперативные сроки поставки под заказ (от 5 рабочих дней);
- Экспресс доставка в любую точку России;
- Техническая поддержка проекта, помощь в подборе аналогов, поставка прототипов;
- Система менеджмента качества сертифицирована по Международному стандарту ISO 9001;
- Лицензия ФСБ на осуществление работ с использованием сведений, составляющих государственную тайну;
- Поставка специализированных компонентов (Xilinx, Altera, Analog Devices, Intersil, Interpoint, Microsemi, Aeroflex, Peregrine, Syfer, Eurofarad, Texas Instrument, Miteq, Cobham, E2V, MA-COM, Hittite, Mini-Circuits, General Dynamics и др.);

Помимо этого, одним из направлений компании «ЭлектроПласт» является направление «Источники питания». Мы предлагаем Вам помощь Конструкторского отдела:

- Подбор оптимального решения, техническое обоснование при выборе компонента;
- Подбор аналогов;
- Консультации по применению компонента;
- Поставка образцов и прототипов;
- Техническая поддержка проекта;
- Защита от снятия компонента с производства.



Как с нами связаться

Телефон: 8 (812) 309 58 32 (многоканальный)

Факс: 8 (812) 320-02-42

Электронная почта: org@eplast1.ru

Адрес: 198099, г. Санкт-Петербург, ул. Калинина, дом 2, корпус 4, литера А.