



Input Attenuator Module

Features & Benefits

- Inputs: 28V_{DC} and 270V_{DC}
- MIL-STD-461C/D/E EMI compliance^[1]
- MIL-STD-810 environments
- MIL-STD-704, MIL-STD-1275 and DO-160 transients and spikes
- Output power: Up to 200W from any combination of MI-200 or MI-J00 modules
- Expansion port for additional power
- Short circuit protected
- Size: 2.28" x 2.4" x 0.5" (57,9 x 61,0 x 12,7mm)

Product Highlights

The MI-IAM is an accessory product to Vicor's MI-Series of DC-DC converters that provides EMI filtering and transient protection. Designed for use with all 28V and 270V input MI-200 or MI-J00 converters, the MI-IAM can drive any number of modules with output loads to 200W. See chapter 14 of the Design Guide & Applications Manual for VI-200 and VI-J00 Family DC-DC Converters and configurable Power Supplies for technical description.

The MI-IAM meets the conducted emissions specifications of MIL-STD-461C/D/E^[1] and offers complete input transient, surge and spike protection to the most severe levels of MIL-STD-1275, MIL-STD-704 and DO-160. Overvoltage lockout provides additional safeguards against potentially damaging line conditions. Higher power arrays can be configured using the expansion port capability of the MI-IAM.

Compatible Products

- MI-200, MI-J00 (Inputs: 2 and 6)
- MI-Mega Modules (Inputs: 2 and 6)

Packaging Options

- Standard:** Slotted baseplate
- SlimMod:** Flangeless baseplate, option suffix: - S
Example: MI - AXX - XX - S
- FinMod:** Finned heat sink, option suffix:
- F1, - F2, -F3 or -F4
Examples:
MI - AXX - XX -F1, 0.25" fins, longitudinal
MI - AXX - XX -F2, 0.50" fins, longitudinal
MI - AXX - XX -F3, 0.25" fins, transverse
MI - AXX - XX -F4, 0.50" fins, transverse

Input Characteristics (Typical at T_{BP} = 25°C, nominal line and 75% load, unless otherwise specified)

Parameter	Min	Typ	Max	Units	Notes
28V _{DC} modules					
Steady state input	16	28	50	V _{DC}	
Input spike limit	-600		600	V _{DC}	20µs, 50Ω per MIL-STD-704A ^[a]
	-250		250	V _{DC}	70µs, 15mJ per MIL-STD-1275A/B/D
Input surge limit			100	V _{DC}	50ms, 0.5Ω per MIL-STD-1275A/B/D
			80	V _{DC}	100ms per DO-160E, Sec.16, Cat. Z
Overvoltage shut down ^[b]	50			V _{DC}	100ms, automatic recovery
Recommended fuse			20	Amps	F03A type
270V _{DC} modules					
Steady state input	100	270	400	V _{DC}	
Input spike limit			800	V _{DC}	20µs, 50Ω ^[a]
	-600		600	V _{DC}	100µs, 50mJ ^[a]
Input surge limit			500	V _{DC}	100ms, 0.5Ω
Overvoltage shut down ^[a]	400			V _{DC}	100ms, automatic recovery
Recommended fuse			4	Amps	F03A type
All models					
No load power dissipation		0.5	1.5	Watts	
Inrush current		110	125	% I _N	Steady state, I _{IN} 10ms

^[a] Guaranteed by design – no test data available.

^[b] The MI-IAM disables downstream converters and clamps the converter input voltage at a safe level.

Output Characteristics

Parameter	Min	Typ	Max	Units	Test Conditions
Clamp voltage					
28V _{DC} input			60	V _{DC}	
270V _{DC} input			420	V _{DC}	
Output power			250	Watts	
Internal voltage drop					
28V _{DC}		0.6		V _{DC}	
270V _{DC}		0.85		V _{DC}	
Overload protection					
28V _{DC} input			20	Amps	Foldback threshold; auto recovery
270V _{DC} input			4	Amps	with latched shut down after 1ms

Isolation Characteristics

Parameter	Min	Typ	Max	Units	Notes
Input to base		1,500		V_{RMS}	1 minute
Output to base		1,500		V_{RMS}	1 minute

EMI Characteristics MIL-STD-461⁽¹⁾

Parameter	Notes
Input power leads	
Conducted emissions	CE01, CE03, CE07 CE101, CE102 MIL-STD-461C MIL-STD-461D/E
Conducted susceptibility	CS01, CS02, CS06, CS101, CS114, CS115, CS116 MIL-STD-461C MIL-STD-461D/E

⁽¹⁾ EMI performance is subject to a wide variety of external influences such as PCB construction, circuit layout etc.

As such, external components in addition to those listed herein may be required in specific instances to gain full compliance to the standards specified.

Model Selection Chart

Model Number	Nominal Input Voltage	Input Range	Compatible MI-Series	Converter
MI-A22-MU	28V _{DC}	16 – 50V _{DC}	MI-22x-Mx and MI-J2x-Mx	M-grade
MI-A66-MU	270V _{DC}	125 – 400V _{DC}	MI-26x-Mx and MI-J6x-Mx	M-grade
MI-A22-IU	28V _{DC}	16 – 50V _{DC}	MI-22x-lx and MI-J2x-lx	I-grade
MI-A66-IU	270V _{DC}	125 – 400V _{DC}	MI-26x-lx and MI-J6x-lx	I-grade

Specifications

(Typical at $T_{BP} = 25^{\circ}\text{C}$, nominal line and 75% load, unless otherwise specified)

ENVIRONMENTAL – MIL-STD-810D

Parameter	Min	Typ	Max	Units	Test Conditions
Altitude - method 500.2	70,000			feet	Procedure II
Humidity - method 507.2	88/240			%/hours	Procedure I, cycle 1
Acceleration - method 513.3	9			g	Procedure II
Vibration - method 514.3	20			g	Procedure I, category 6
Shock - method 516.3	40			g	Procedure I

RELIABILITY – MIL-HDBK-217F (MI-A22-MU)

Parameter	Min	Typ	Max	Units	Test Conditions
25°C Ground Benign: G.B.		5,637		1,000 hours	
50°C Naval Sheltered: N.S.		1,014		1,000 hours	
65°C Airborne Inhabited Cargo: A.I.C.		795		1,000 hours	

THERMAL CHARACTERISTICS

Parameter	Min	Typ	Max	Units	Test Conditions
Efficiency		97		%	
Baseplate to sink		0.14		$^{\circ}\text{C}/\text{Watt}$	
Operating temperature, baseplate			100	$^{\circ}\text{C}$	See product grade specifications
Storage temperature			125	$^{\circ}\text{C}$	See product grade specifications

MECHANICAL SPECIFICATIONS

Parameter	Min	Typ	Max	Units	Test Conditions
Weight		3.0 (85)		ounces (grams)	

PRODUCT GRADE SPECIFICATIONS

Parameter	I-Grade	M-Grade
Storage temperature	-55°C to +125°C	-65°C to +125°C
Operating temperature (baseplate)	-40°C to +100°C	-55°C to +100°C
Power cycling burn-in	12 hours, 29 cycles	96 hours, 213 cycles
Temperature cycled with power off 17°C per minute rate of change	12 cycles -65°C to +100°C	12 cycles -65°C to +100°C
Test data supplied at these temperatures ^[a]	-40°C, +80°C	-55°C, +80°C
Warranty	2 years	2 years
Environmental compliance	MIL-STD-810	MIL-STD-810
Derating	NAVMAT P-4855-1A	NAVMAT P-4855-1A

^[a] Test data available for review or download from vicorpower.com

Specifications (Cont.)

ENVIRONMENTAL QUALIFICATIONS

Parameter	Qualification
Altitude	MIL-STD-810D, Method 500.2, Procedure III, explosive decompression (40K ft.).
	MIL-STD-810D, Method 500.2, Procedure II, 40,000ft., 1000 – 1500ft./min. to 70,000ft., unit functioning
Explosive Atmosphere	MIL-STD-810C, Method 511.1, Procedure I
Vibration	MIL-STD-810D, Method 514.3, Procedure I, category 6, helicopter, 20g
	MIL-STD-810D, Method 514.3 random: 10 – 300Hz @ 0.02g ² /Hz, 2000Hz @ 0.002g ² /Hz, 3.9 total Grms 3hrs/axis. Sine: 30Hz @ 20g, 60Hz @ 10g, 90Hz @ 6.6g, 120Hz @ 5.0g, 16.0 total Grms, 3 axes
	MIL-STD-810E, Method 514.4, Table 514.4-VII, ±6db/octave, 7.7Grms, 1hr/axis
Shock	MIL-STD-810D, Method 516.3, Procedure I, functional shock, 40g
	MIL-STD-202F, Method 213B, 18 pulses, 60g, 9msec
	MIL-STD-202F, Method 213B, 75g, 11ms saw tooth shock
	MIL-STD-202F, Method 207A, 3 impacts / axis, 1, 3, 5 feet
Acceleration	MIL-STD-810D, Method 513.3, Procedure II Operational test, 9g for 1 minute along 3 mutually perpendicular axes
Humidity	MIL-STD-810D, Method 507.2, Procedure I, cycle I, 240 hrs, 88% relative humidity
Solder Test	MIL-STD-202, Method 208, 8hr. aging
Fungus	MIL-STD-810C, Method 508.1
Salt-Fog	MIL-STD-810C, Method 509.1

Safe Operating Area ^[a]

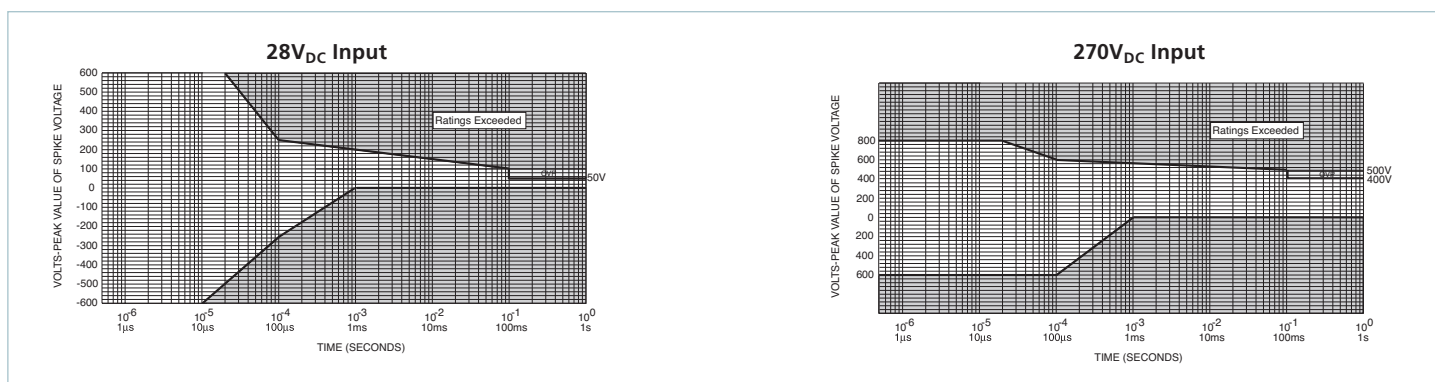

^[a] Refer to Input Characteristics

Typical Connection Diagram

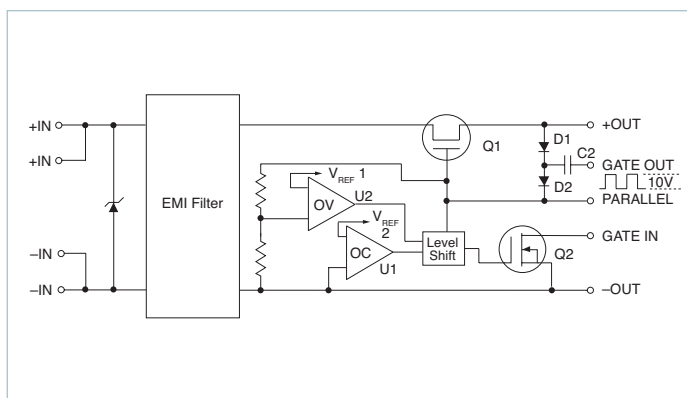
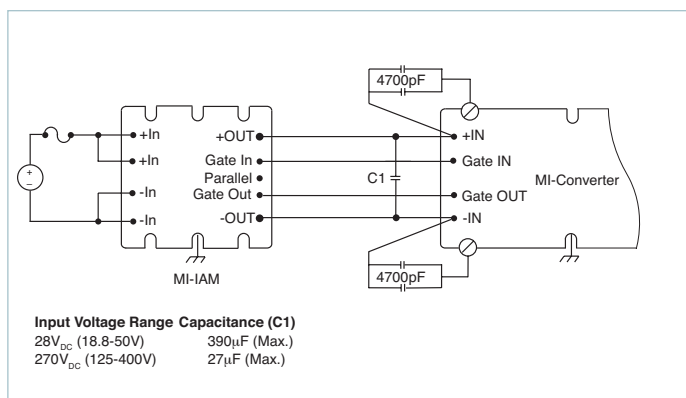

Storage

Vicor products, when not installed in customer units, should be stored in ESD safe packaging in accordance with ANSI/ESD S20.20, "Protection of Electrical and Electronic Parts, Assemblies and Equipment" and should be maintained in a temperature controlled factory/warehouse environment not exposed to outside elements controlled between the temperature ranges of 15°C and 38°C. Humidity shall not be condensing, no minimum humidity when stored in an ESD compliant package.

Mechanical Drawing

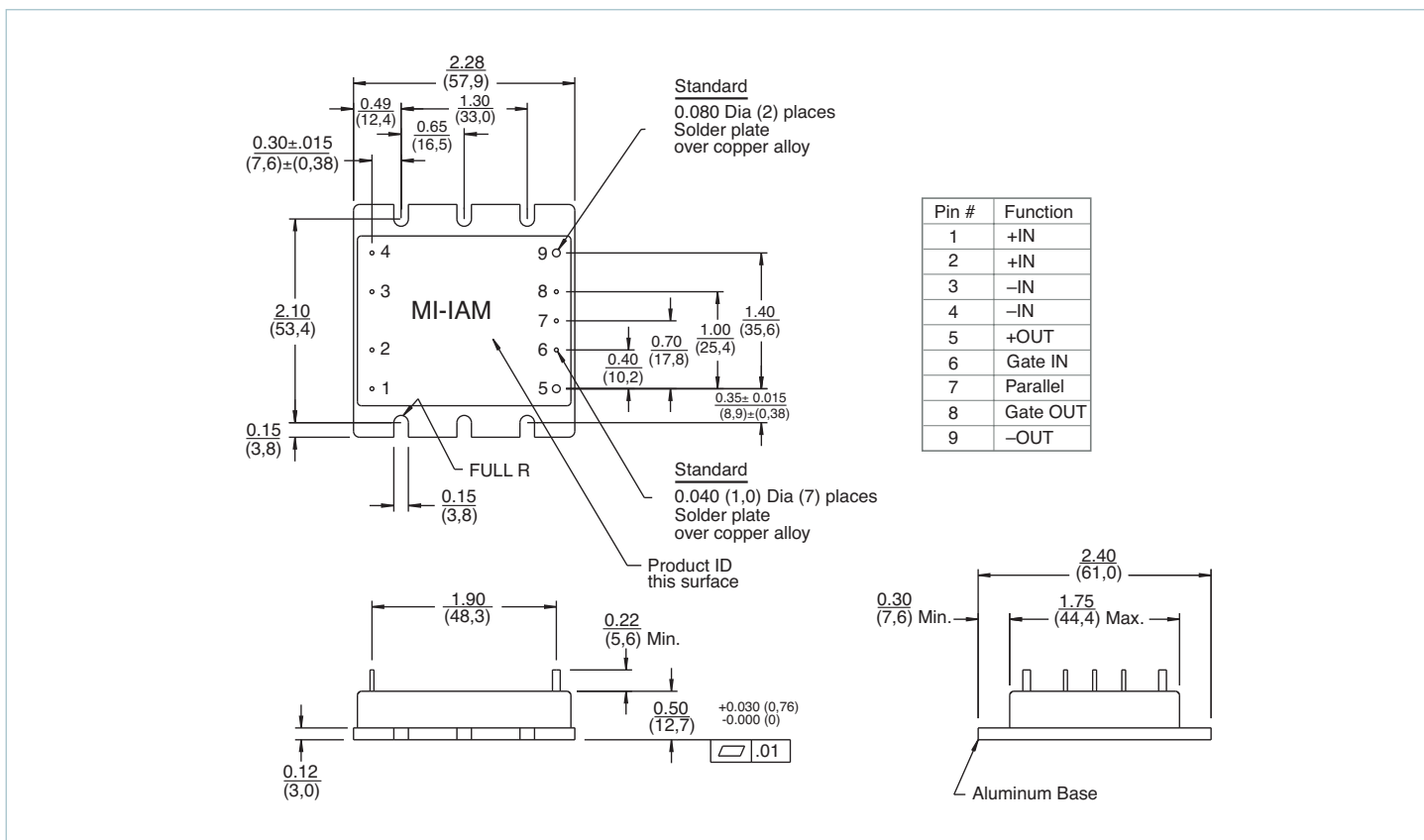

Note: For alternate packaging options refer to the mechanical drawing page of vicorpower.com

^[1] EMI performance is subject to a wide variety of external influences such as PCB construction, circuit layout etc. As such, external components in addition to those listed herein may be required in specific instances to gain full compliance to the standards specified.

Vicor's comprehensive line of power solutions includes high density AC-DC and DC-DC modules and accessory components, fully configurable AC-DC and DC-DC power supplies, and complete custom power systems.

Information furnished by Vicor is believed to be accurate and reliable. However, no responsibility is assumed by Vicor for its use. Vicor makes no representations or warranties with respect to the accuracy or completeness of the contents of this publication. Vicor reserves the right to make changes to any products, specifications, and product descriptions at any time without notice. Information published by Vicor has been checked and is believed to be accurate at the time it was printed; however, Vicor assumes no responsibility for inaccuracies. Testing and other quality controls are used to the extent Vicor deems necessary to support Vicor's product warranty. Except where mandated by government requirements, testing of all parameters of each product is not necessarily performed.

Specifications are subject to change without notice.

Visit http://www.vicorpower.com/mil-cots_dc-dc/mil-cots_mi-iam_input_attenuator_module for the latest product information.

Vicor's Standard Terms and Conditions and Product Warranty

All sales are subject to Vicor's Standard Terms and Conditions of Sale, and Product Warranty which are available on Vicor's webpage (<http://www.vicorpower.com/termsconditionswarranty>) or upon request.

Life Support Policy

VICOR'S PRODUCTS ARE NOT AUTHORIZED FOR USE AS CRITICAL COMPONENTS IN LIFE SUPPORT DEVICES OR SYSTEMS WITHOUT THE EXPRESS PRIOR WRITTEN APPROVAL OF THE CHIEF EXECUTIVE OFFICER AND GENERAL COUNSEL OF VICOR CORPORATION. As used herein, life support devices or systems are devices which (a) are intended for surgical implant into the body, or (b) support or sustain life and whose failure to perform when properly used in accordance with instructions for use provided in the labeling can be reasonably expected to result in a significant injury to the user. A critical component is any component in a life support device or system whose failure to perform can be reasonably expected to cause the failure of the life support device or system or to affect its safety or effectiveness. Per Vicor Terms and Conditions of Sale, the user of Vicor products and components in life support applications assumes all risks of such use and indemnifies Vicor against all liability and damages.

Intellectual Property Notice

Vicor and its subsidiaries own Intellectual Property (including issued U.S. and Foreign Patents and pending patent applications) relating to the products described in this data sheet. No license, whether express, implied, or arising by estoppel or otherwise, to any intellectual property rights is granted by this document. Interested parties should contact Vicor's Intellectual Property Department.

Vicor Corporation

25 Frontage Road
Andover, MA, USA 01810
Tel: 800-735-6200
Fax: 978-475-6715

email

Customer Service: custserv@vicorpower.com
Technical Support: apps@vicorpower.com

Mouser Electronics

Authorized Distributor

Click to View Pricing, Inventory, Delivery & Lifecycle Information:

[Vicor:](#)

[MI-A22-IU](#) [MI-A66-MU-B1](#) [MI-A22-MU-S](#) [MI-AIM-M1](#) [MI-A22-MU-01](#) [MI-A22-IU-S](#) [MI-A66-IU-F4](#) [MI-A22-MU-B1](#)
[MI-A22-IU-10](#) [MI-A66-MU](#) [MI-AIM-I1-B1](#) [MI-A66-IU-S](#) [MI-AIM-I1-F2](#) [MI-A66-MU-F1](#) [MI-A66-MU-S](#) [MI-AIM-M1-S](#) [MI-](#)
[A22-IU-05](#) [MI-A22-IU-F2](#) [MI-A22-IU-F4](#) [MI-A66-IU-B1](#) [MI-A22-IU-B1](#) [MI-AIM-I1](#) [MI-AIM-I1-S](#) [MI-A22-IU-02](#) [MI-A22-](#)
[MU](#) [MI-A22-IU-F1](#) [MI-AIM-M1-B1](#) [MI-A66-IU](#) [MI-AIM-I1-F4](#) [MI-A22-IU-07-S](#)



Компания «ЭлектроПласт» предлагает заключение долгосрочных отношений при поставках импортных электронных компонентов на взаимовыгодных условиях!

Наши преимущества:

- Оперативные поставки широкого спектра электронных компонентов отечественного и импортного производства напрямую от производителей и с крупнейших мировых складов;
- Поставка более 17-ти миллионов наименований электронных компонентов;
- Поставка сложных, дефицитных, либо снятых с производства позиций;
- Оперативные сроки поставки под заказ (от 5 рабочих дней);
- Экспресс доставка в любую точку России;
- Техническая поддержка проекта, помощь в подборе аналогов, поставка прототипов;
- Система менеджмента качества сертифицирована по Международному стандарту ISO 9001;
- Лицензия ФСБ на осуществление работ с использованием сведений, составляющих государственную тайну;
- Поставка специализированных компонентов (Xilinx, Altera, Analog Devices, Intersil, Interpoint, Microsemi, Aeroflex, Peregrine, Syfer, Eurofarad, Texas Instrument, Miteq, Cobham, E2V, MA-COM, Hittite, Mini-Circuits, General Dynamics и др.);

Помимо этого, одним из направлений компании «ЭлектроПласт» является направление «Источники питания». Мы предлагаем Вам помощь Конструкторского отдела:

- Подбор оптимального решения, техническое обоснование при выборе компонента;
- Подбор аналогов;
- Консультации по применению компонента;
- Поставка образцов и прототипов;
- Техническая поддержка проекта;
- Защита от снятия компонента с производства.



Как с нами связаться

Телефон: 8 (812) 309 58 32 (многоканальный)

Факс: 8 (812) 320-02-42

Электронная почта: org@eplast1.ru

Адрес: 198099, г. Санкт-Петербург, ул. Калинина, дом 2, корпус 4, литера А.