



LIGHTING FOREVER

6 PIN DIP RANDOM-PHASE TRIAC DRIVER PHOTOCOUPLER

EL301X Series
EL302X Series
EL305X Series

Features:

- Peak breakdown voltage
 - 250V: EL301X
 - 400V: EL302X
 - 600V: EL305X
- High isolation voltage between input and output (Viso=5000 V rms)
- Compact dual-in-line package
- Pb free and RoHS compliant.
- UL approved (No. E214129)
- VDE approved (No.132249)
- SEMKO approved
- NEMKO approved
- DEMKO approved
- FIMKO approved
- CSA approved

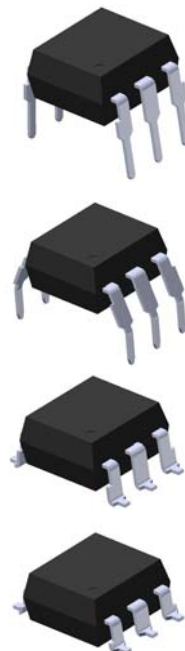

Description

The EL301X, EL302X and EL305X series of devices each consist of a GaAs infrared emitting diode optically coupled to a monolithic silicon random phase photo Triac.

They are designed for interfacing between electronic controls and power triacs to control resistive and inductive loads for 115 to 240 VAC operations.

Applications

- Solenoid/valve controls
- Lamp ballasts
- Static AC power switch
- Interfacing microprocessors to 115 to 240Vac peripherals
- Incandescent lamp dimmers
- Temperature controls
- Motor controls

Schematic

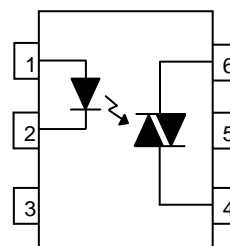

Pin Configuration

1. Anode
2. Cathode
3. No Connection
4. Terminal
5. Substrate
(do not connect)
6. Terminal



LIGHTING FOREVER

6 PIN DIP RANDOM-PHASE TRIAC DRIVER PHOTOCOUPLER

EL301X Series
EL302X Series
EL305X Series

Absolute Maximum Ratings (T_a=25°C)

Parameter		Symbol	Rating	Unit	
Input	Forward current	I _F	60	mA	
	Reverse voltage	V _R	6	V	
	Power dissipation Derating factor (above 85°C)	P _D	100	mW	
	3.8		mW /°C		
Output	Off-state Output Terminal Voltage	V _{DRM}	250	V	
			EL302X		400
			EL305X		600
	Peak Repetitive Surge Current	I _{TSM}	1	A	
	Power dissipation Derating factor (above 85°C)	P _D	300	mW	
	7.4		mW /°C		
Isolation voltage *1		V _{iso}	5000	V rms	
Total power dissipation		P _D	330	mW	
Operating temperature		T _{opr}	-55~+100	°C	
Storage temperature		T _{stg}	-55~+125	°C	
Soldering temperature *2		T _{sol}	260	°C	

Notes

*1 AC for 1 minute, R.H.= 40 ~ 60% R.H. In this test, pins 1, 2 & 3 are shorted together, and pins 4, 5 & 6 are shorted together.

*2 For 10 seconds.

6 PIN DIP RANDOM-PHASE TRIAC DRIVER PHOTOCOUPLER

EL301X Series
EL302X Series
EL305X Series

Electrical Characteristics ($T_a=25^\circ\text{C}$ unless specified otherwise)

Input

Parameter	Symbol	Min.	Typ.*	Max.	Unit	Condition
Forward voltage	V_F	-	1.18	1.5	V	$I_F = 10\text{mA}$
Reverse Leakage current	I_R	-	-	10	μA	$V_R = 6\text{V}$

Output

Parameter	Symbol	Min.	Typ.*	Max.	Unit	Condition
Peak Blocking Current	I_{DRM}	-	-	100	nA	$V_{\text{DRM}} = \text{Rated } V_{\text{DRM}}$ $I_F = 0\text{mA}$
Peak On-state Voltage	V_{TM}	-	-	2.5	V	$I_{\text{TM}}=100\text{mA peak}$, $I_F=\text{Rated } I_{\text{FT}}$
Critical Rate of Rise off-state Voltage	EL301X EL302X	-	100	-	$\text{V}/\mu\text{s}$	$V_{\text{PEAK}} = \text{Rated } V_{\text{DRM}}$, $I_F=0$ (Fig. 8)
	EL305X	1000	-	-		$V_{\text{PEAK}} = 400\text{V}$, $I_F=0$ (Fig. 8)

Transfer Characteristics

Parameter	Symbol	Min.	Typ.*	Max.	Unit	Condition
LED Trigger Current	EL3010 EL3021 EL3051	-	-	15	mA	Main terminal Voltage=3V
	EL3011 EL3022 EL3052	-	-	10		
	EL3012 EL3023 EL3053	-	-	5		
Holding Current	I_H	-	250	-	μA	

* Typical values at $T_a = 25^\circ\text{C}$

6 PIN DIP RANDOM-PHASE TRIAC DRIVER PHOTOCOUPLER

EL301X Series
EL302X Series
EL305X Series

Typical Performance Curves

Figure 1. Forward Current vs Forward Voltage

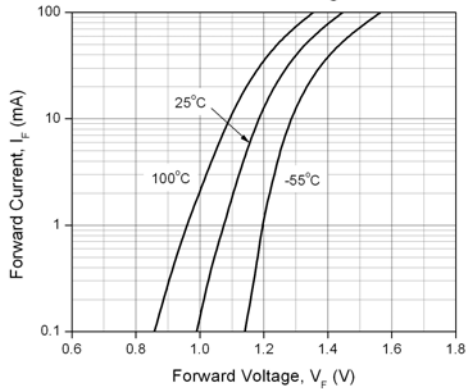

Figure 2. On-State Characteristics

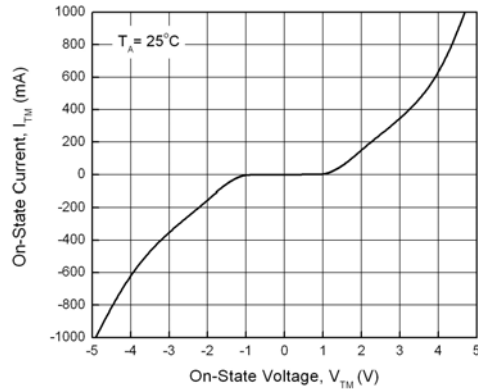

Figure 3. Holding Current vs. Ambient Temperature

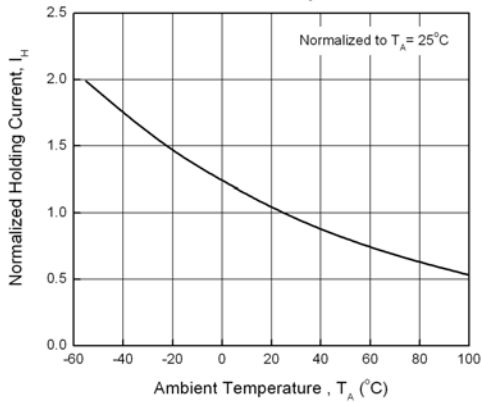

Figure 4. LED Current Required to Trigger vs. LED Pulse Width

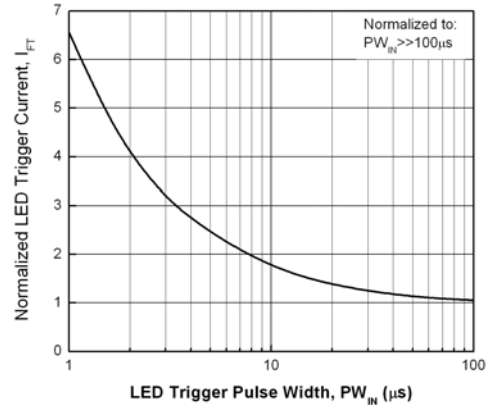

Figure 5. Leakage Current vs. Ambient Temperature

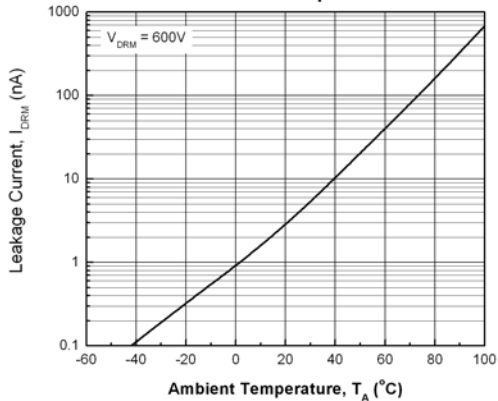
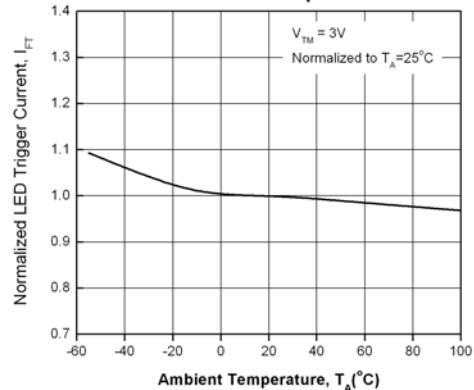

Figure 6. LED Trigger Current vs. Ambient Temperature



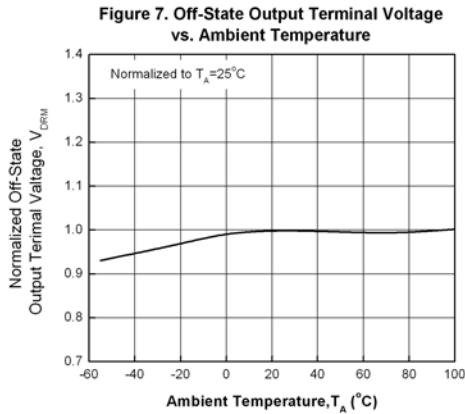
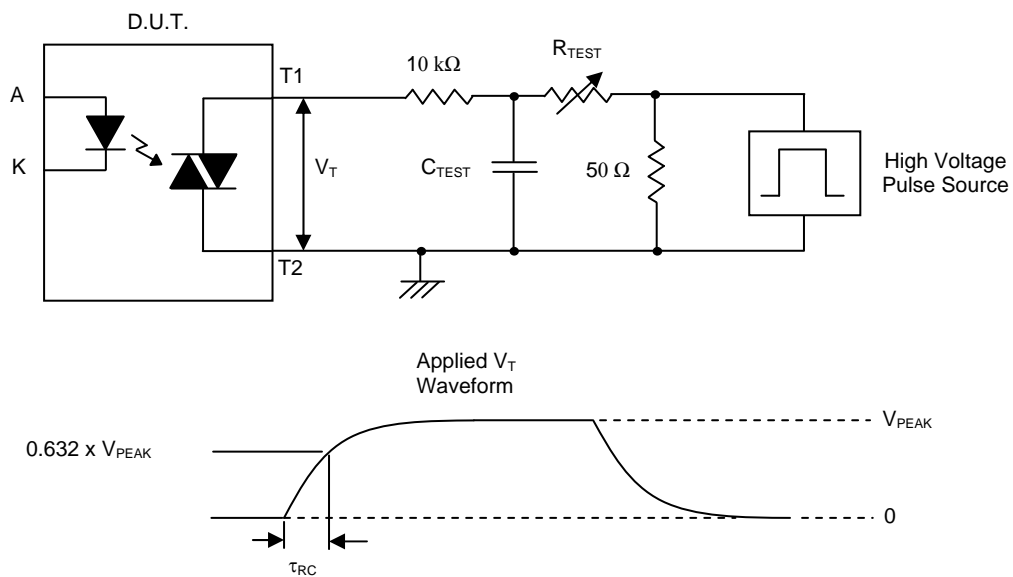

Figure 8. Static dv/dt Test Circuit & Waveform



Measurement Method

The high voltage pulse is set to the required V_{PEAK} value and applied to the D.U.T. output side through the RC circuit above. LED current is not applied. The waveform V_T is monitored using a x100 scope probe. By varying R_{TEST} , the dv/dt (slope) is increased, until the D.U.T. is observed to trigger (waveform collapses). The dv/dt is then decreased until the D.U.T. stops triggering. At this point, τ_{RC} is recorded and the dv/dt calculated.

$$dv/dt = \frac{0.632 \times V_{PEAK}}{\tau_{RC}}$$



LIGHTING FOREVER

6 PIN DIP RANDOM-PHASE TRIAC DRIVER PHOTOCOUPLER

EL301X Series
EL302X Series
EL305X Series

For example, $V_{PEAK} = 400V$ for EL302X series. The dv/dt value is calculated as follows:

$$dv/dt = \frac{0.63 \times 400}{\tau_{RC}} = \frac{252}{\tau_{RC}}$$

Order Information

Part Number

EL301XY(Z)-V
or **EL302XY(Z)-V**
or **EL305XY(Z)-V**

Note

X = Part No. for EL301x (0, 1 or 2)
X = Part No. for EL302x, EL305x (1, 2 or 3)
Y = Lead form option (S, S1, M or none)
Z = Tape and reel option (TA, TB or none).
V = VDE safety approved option

Option	Description	Packing quantity
None	Standard DIP-6	65 units per tube
M	Wide lead bend (0.4 inch spacing)	65 units per tube
S (TA)	Surface mount lead form + TA tape & reel option	1000 units per reel
S (TB)	Surface mount lead form + TB tape & reel option	1000 units per reel
S1 (TA)	Surface mount lead form (low profile) + TA tape & reel option	1000 units per reel
S1 (TB)	Surface mount lead form (low profile) + TB tape & reel option	1000 units per reel

**6 PIN DIP RANDOM-PHASE TRIAC DRIVER
PHOTOCOUPLER**

**EL301X Series
EL302X Series
EL305X Series**

**Package Drawings
(Dimensions in mm)**

Standard DIP Type

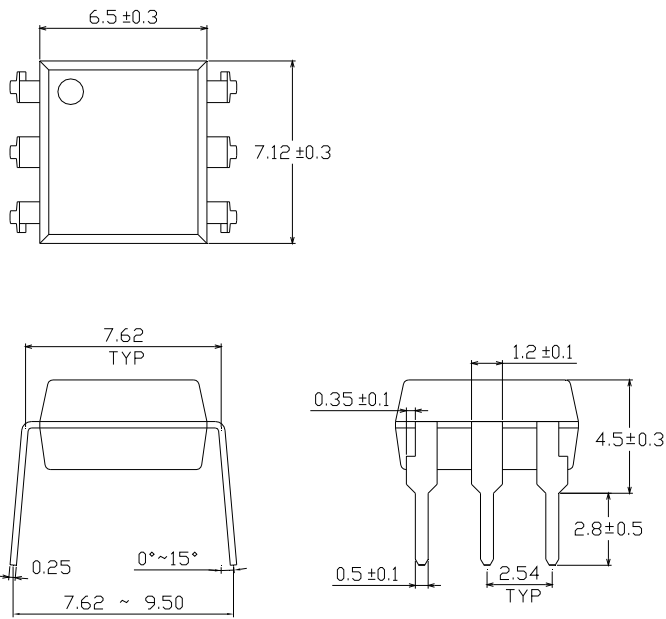

Option M Type

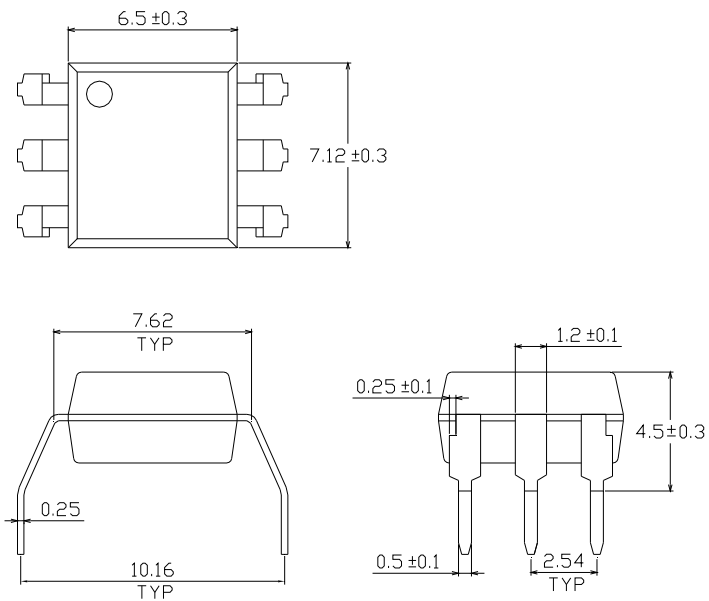

**6 PIN DIP RANDOM-PHASE TRIAC DRIVER
PHOTOCOUPLER**

**EL301X Series
EL302X Series
EL305X Series**

Option S Type

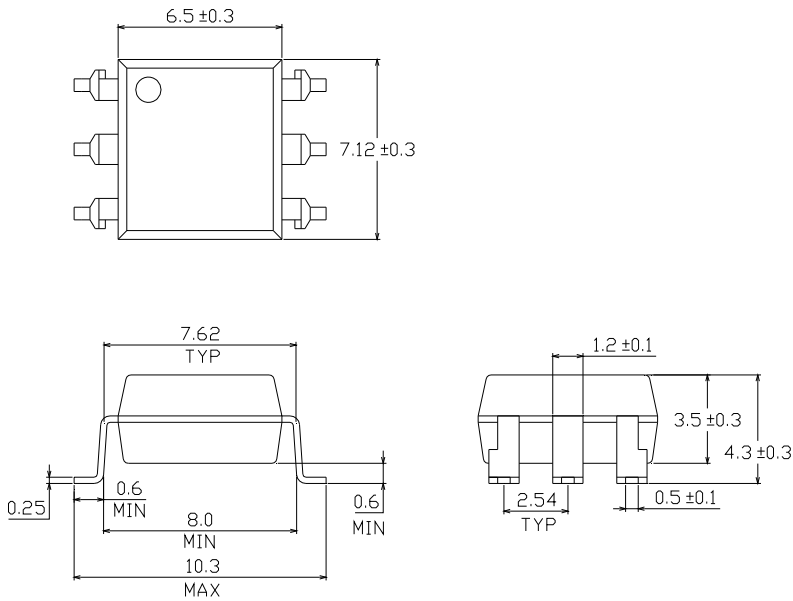

Option S1 Type

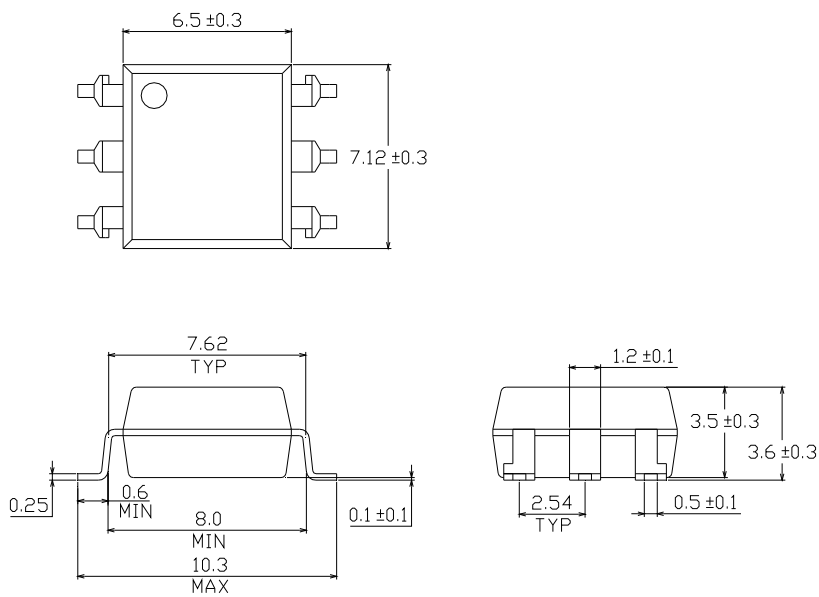

**6 PIN DIP RANDOM-PHASE TRIAC DRIVER
PHOTOCOUPLER**

**EL301X Series
EL302X Series
EL305X Series**

Recommended pad layout for surface mount leadform

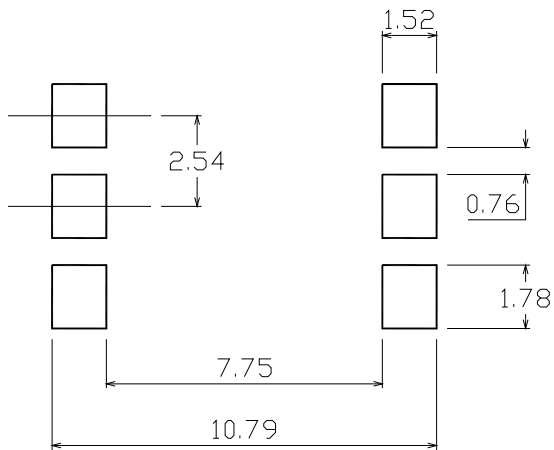

Device Marking

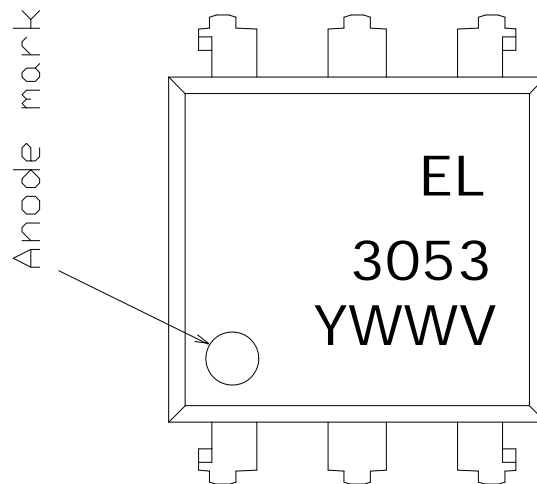

Notes

- EL denotes Everlight
- 3053 denotes Device Number
- Y denotes 1 digit Year code
- WW denotes 2 digit Week code
- V denotes VDE option

6 PIN DIP RANDOM-PHASE TRIAC DRIVER PHOTOCOUPLER

**EL301X Series
EL302X Series
EL305X Series**

Tape & Reel Packing Specifications

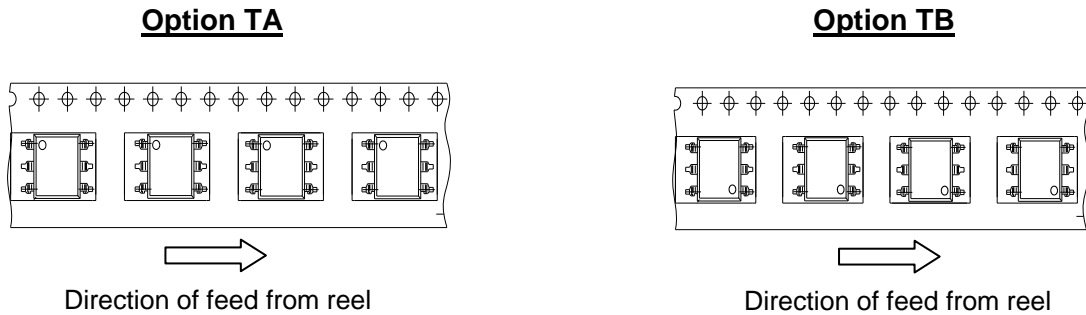

Tape dimensions

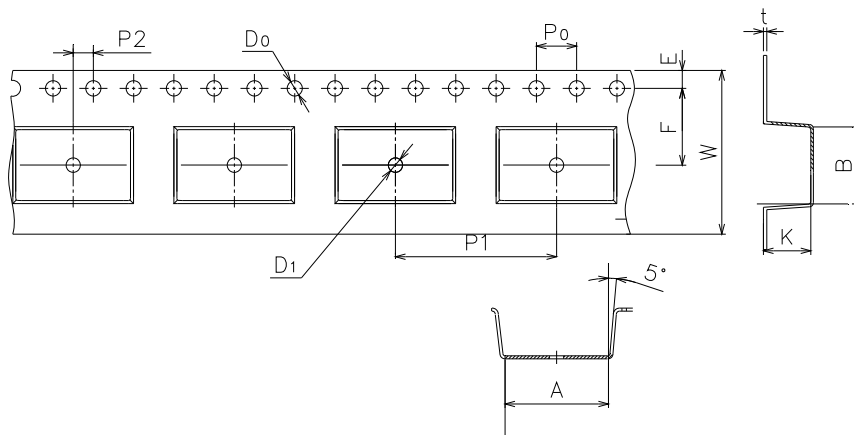

Dimension No.	A	B	Do	D1	E	F
Dimension (mm)	10.4±0.1	7.52±0.1	1.5+0.1/-0	1.5+0.1/-0	1.75±0.1	7.5±0.1

Dimension No.	Po	P1	P2	t	W	K
Dimension (mm)	4.0±0.15	1.6±0.1	2.0±0.1	0.35±0.03	16.0±0.2	4.5±0.1



LIGHTING FOREVER

6 PIN DIP RANDOM-PHASE TRIAC DRIVER PHOTOCOUPLER

EL301X Series
EL302X Series
EL305X Series

Solder Reflow Temperature Profile

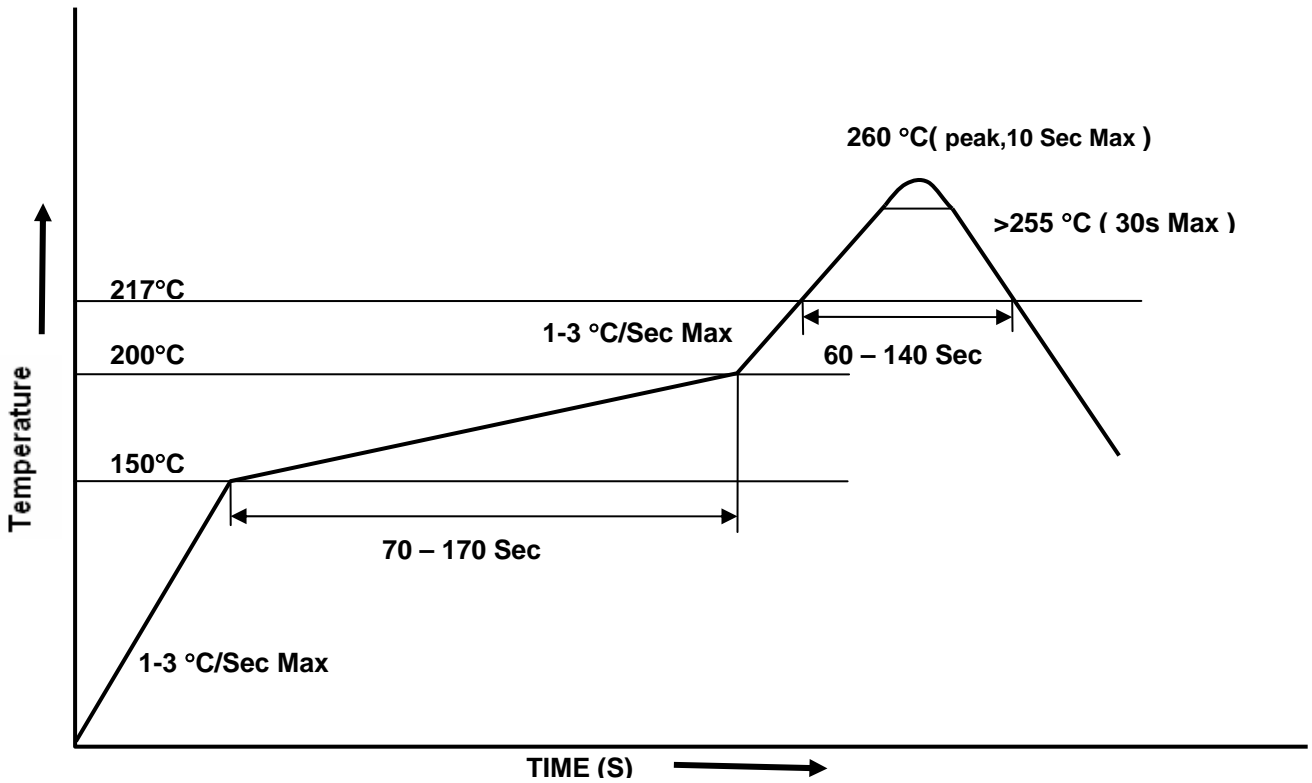



LIGHTING FOREVER

6 PIN DIP RANDOM-PHASE TRIAC DRIVER PHOTOCOUPLER

EL301X Series
EL302X Series
EL305X Series

DISCLAIMER

1. Above specification may be changed without notice. EVERLIGHT will reserve authority on material change for above specification.
2. When using this product, please observe the absolute maximum ratings and the instructions for use outlined in these specification sheets. EVERLIGHT assumes no responsibility for any damage resulting from use of the product which does not comply with the absolute maximum ratings and the instructions included in these specification sheets.
3. These specification sheets include materials protected under copyright of EVERLIGHT. Reproduction in any form is prohibited without the specific consent of EVERLIGHT.



Компания «ЭлектроПласт» предлагает заключение долгосрочных отношений при поставках импортных электронных компонентов на взаимовыгодных условиях!

Наши преимущества:

- Оперативные поставки широкого спектра электронных компонентов отечественного и импортного производства напрямую от производителей и с крупнейших мировых складов;
- Поставка более 17-ти миллионов наименований электронных компонентов;
- Поставка сложных, дефицитных, либо снятых с производства позиций;
- Оперативные сроки поставки под заказ (от 5 рабочих дней);
- Экспресс доставка в любую точку России;
- Техническая поддержка проекта, помощь в подборе аналогов, поставка прототипов;
- Система менеджмента качества сертифицирована по Международному стандарту ISO 9001;
- Лицензия ФСБ на осуществление работ с использованием сведений, составляющих государственную тайну;
- Поставка специализированных компонентов (Xilinx, Altera, Analog Devices, Intersil, Interpoint, Microsemi, Aeroflex, Peregrine, Syfer, Eurofarad, Texas Instrument, Miteq, Cobham, E2V, MA-COM, Hittite, Mini-Circuits, General Dynamics и др.);

Помимо этого, одним из направлений компании «ЭлектроПласт» является направление «Источники питания». Мы предлагаем Вам помощь Конструкторского отдела:

- Подбор оптимального решения, техническое обоснование при выборе компонента;
- Подбор аналогов;
- Консультации по применению компонента;
- Поставка образцов и прототипов;
- Техническая поддержка проекта;
- Защита от снятия компонента с производства.



Как с нами связаться

Телефон: 8 (812) 309 58 32 (многоканальный)

Факс: 8 (812) 320-02-42

Электронная почта: org@eplast1.ru

Адрес: 198099, г. Санкт-Петербург, ул. Калинина, дом 2, корпус 4, литера А.