

SPECIFICATION

Part No.	:	OMB.868.B05F21
Description	:	Barracuda 5dBi 868MHz ISM Band Indoor/Outdoor Omnidirectional Antenna
Features	:	Omni-Directional Radiation Pattern Collinear 5 dBi Peak Gain Robust Design for all Weather operation IP65 Waterproof Length: 818.75mm, Weight: 580g Connector: N-type Female Wall/Pole Mount Bracket Included RoHS compliant



1. Introduction

The Barracuda 868MHz ISM Outdoor antenna is designed to have a long distance coverage. Omni-directional high gain across all bands ensures constant reception and transmission. The UV resistant coating with fiberglass housing makes this antenna suitable to be mounted in robust outdoor environment, pole-mounting and wall-mounting bracket is included.

The antenna finds its usage in metering, industrial monitoring and security applications.

This antenna is suitable to use as part of narrow channel M2M Sigfox Network, for simple M2M management in cities. The main applications would be Smart Cities, Utilities, Public Transport.

2. Specification

ELECTRICAL	
Standard	ISM 868
Band	860~870MHz
Antenna Type	Collinear
Gain(max)	5dBi
Polarization	Vertical
Impedance	50 ohms
Max Input Power	50 watts
VSWR	<1.5:1
Radiation	Omnidirectional
Vertical Beam-width	16 Deg
Horizontal Beam-width	360 Deg
Antenna Design	Dipole Array
Internal Material	Copper
Connector	N Type Female
MECHANICAL	
Length	818.75mm(Max)
Bracket Dimension	70*53mm(Max)
Radome Diameter	24mm
Antenna Weight	580g
Mounting Accessories	70g
Application	Indoor/Outdoor
Radome Material	White Fiberglass
Base Material	Aluminum
Mount Style	Pole Mount/Wall Mount
Mounting	Stainless Steel
Wind Resistance	>150mph(>241km/h)
Housing	Fiberglass
ENVIRONMENTAL	
Storage Temperature	-40°C to +80°C
Operating Temperature	-40°C to +60°C
Operating Humidity	10%~90% non-condensing
Storage Humidity	5%~90% non-condensing

3. Antenna Characteristics

3.1 Return Loss

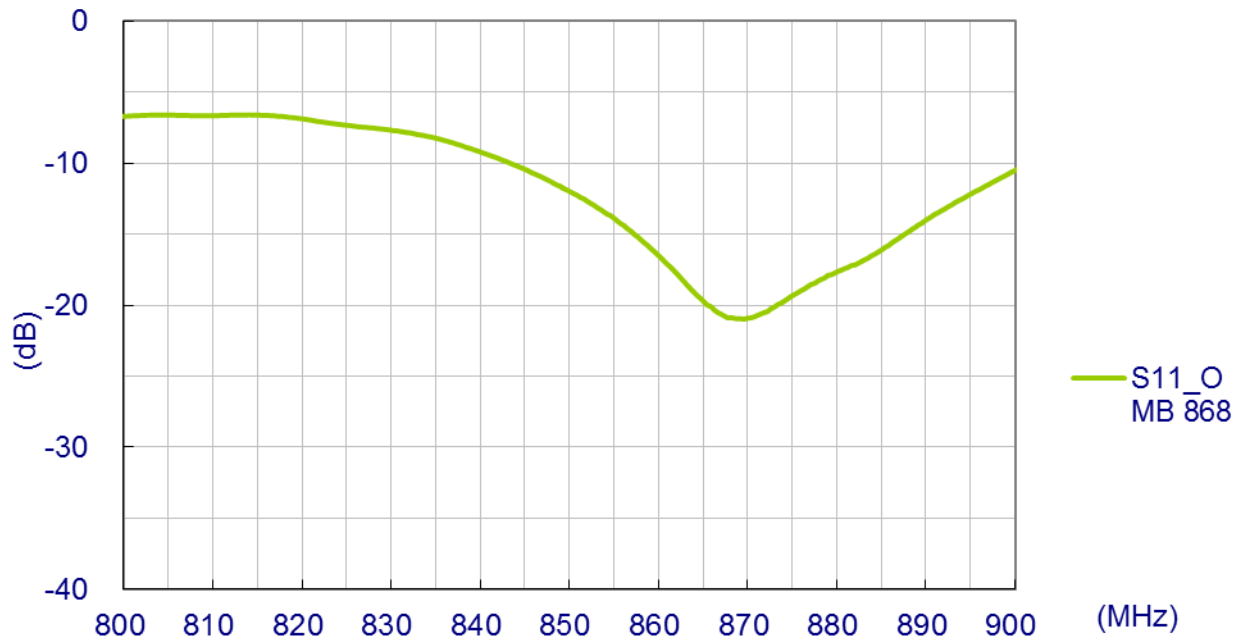

3.2 Maximum Gain

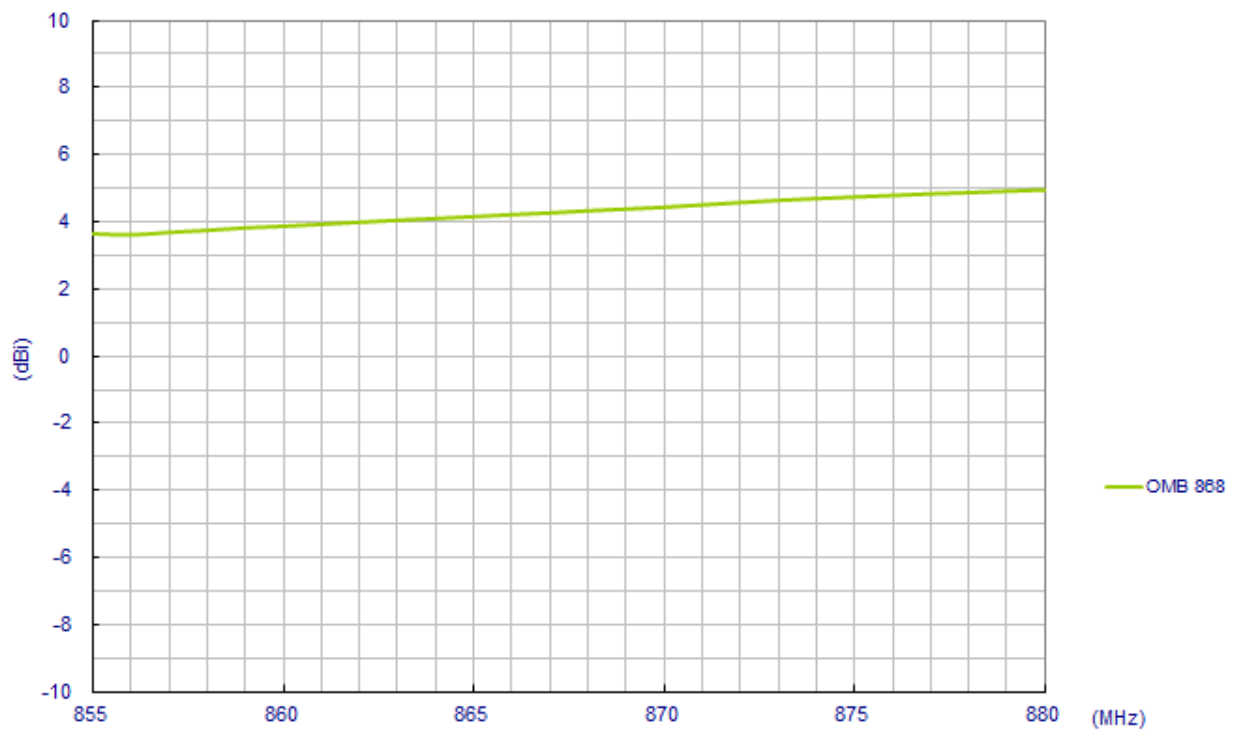

3.3 Average Gain

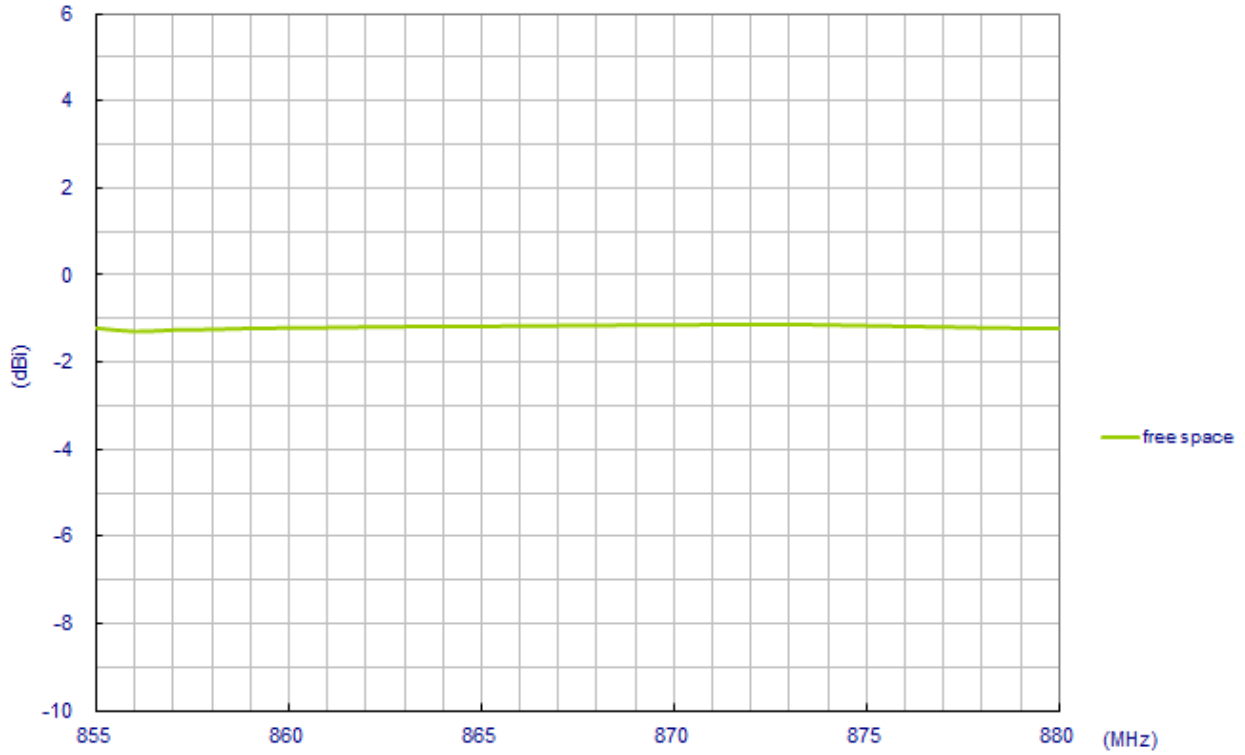

3.4 Efficiency

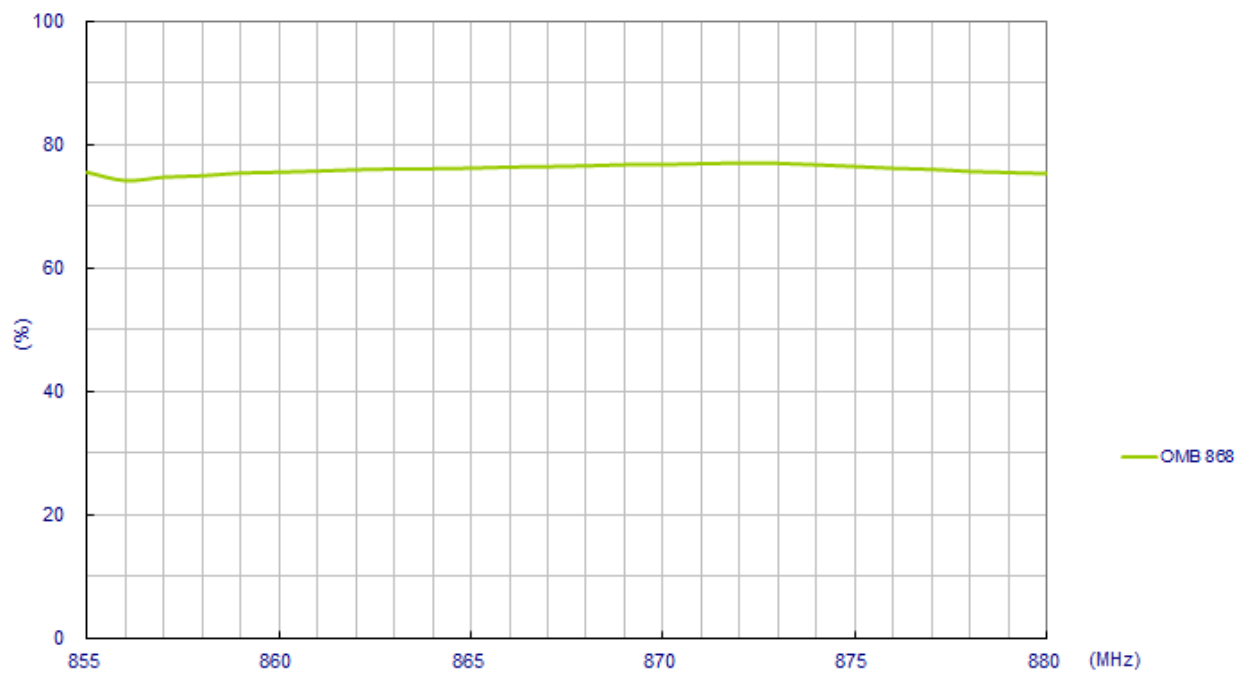

4. 3D Radiation Property

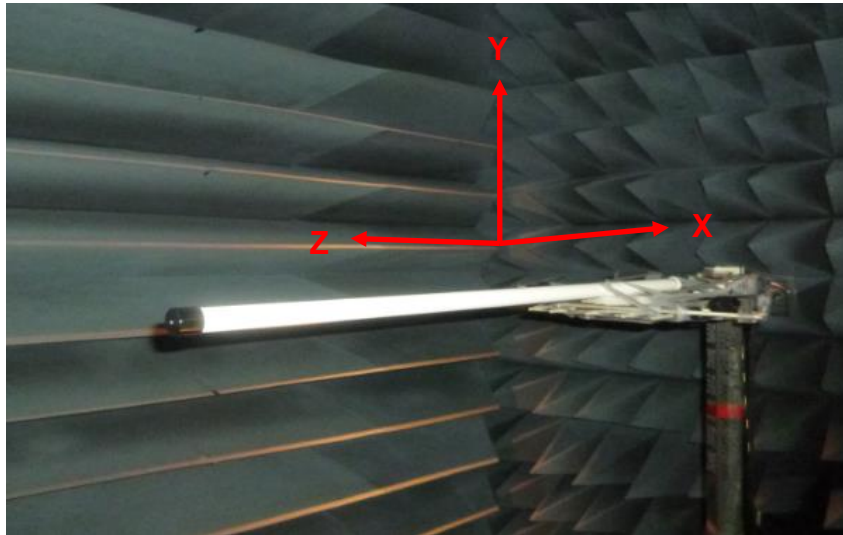

XY Plane

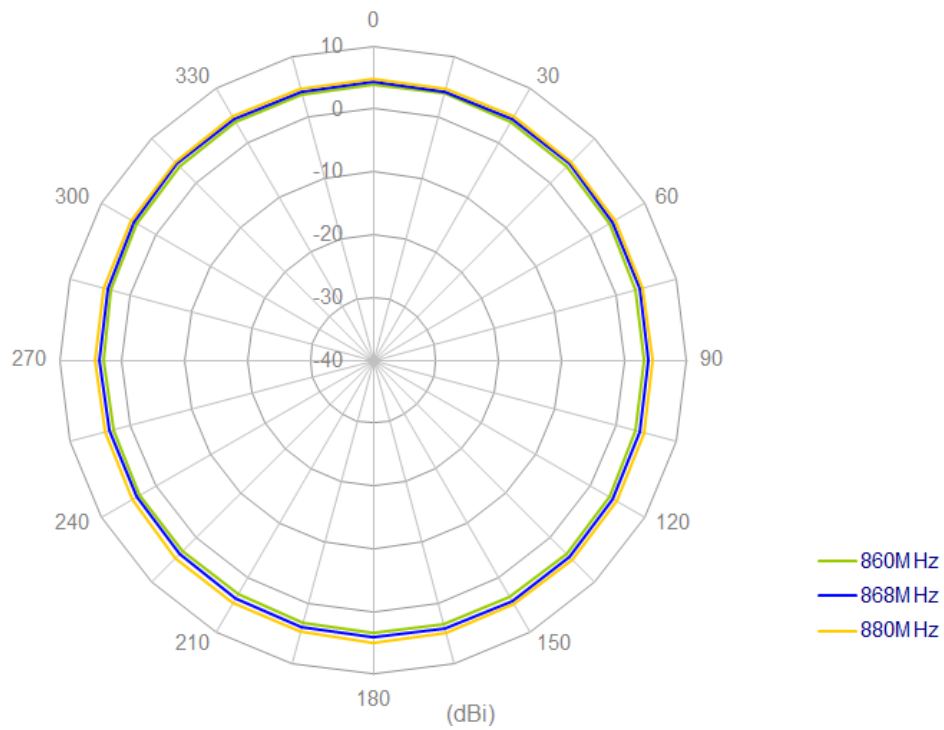

XZ Plane

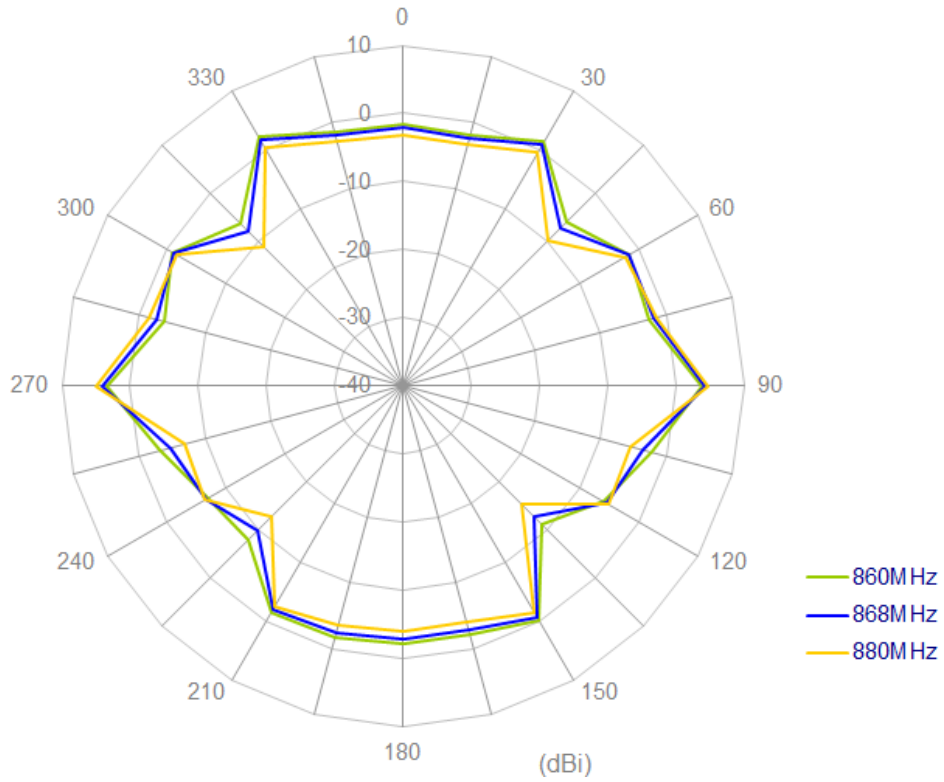

5. Drawing

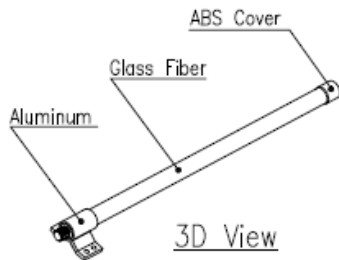

Top View

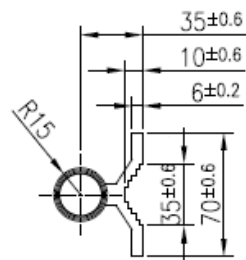

Front View

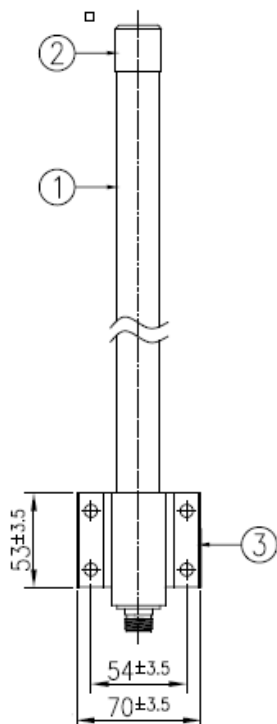

Side View

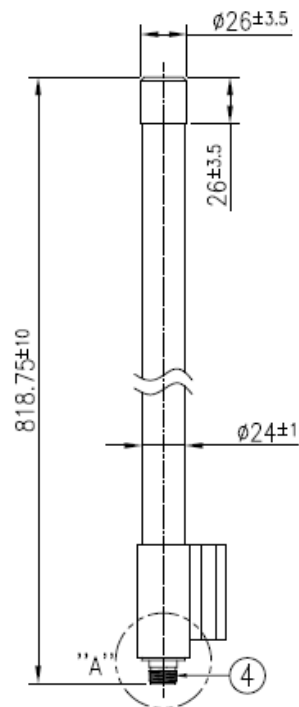

U-Bolt

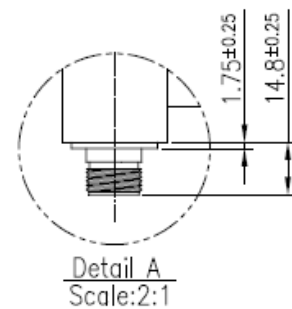
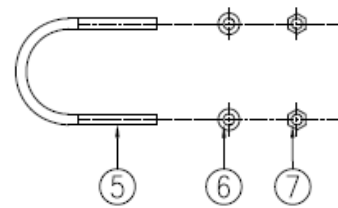

	Name	P/N	Material	Finish	QTY
1	OMB.868 Antenna	001212B010021A	Glass Fiber	White	1
2	Cover	000111K000021A	ABS	Silver	1
3	Bracket	000312B000021A	Aluminum	Silver	1
4	N Type(F)	201211K000021A	Brass	Ni Plated	1
5	M6 U Bolt	000412B000021A	Stainless Steel	Silver	2
6	M6 Washer	000411K010021A	Stainless Steel	Silver	4
7	M6 Nut	000411K020021A	Stainless Steel	Silver	4

6. Packaging Spec

1 OMB.868.B05F21 per tube
 Tube Dimensions - Ø80mm*Height 870mm
 Total Weight - 835g

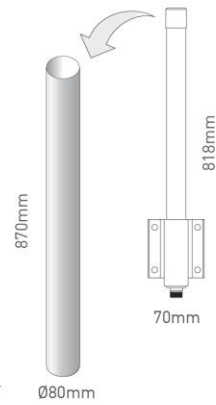

10 tubes per carton
 10 pcs OMB.868.B05F21 per carton
 Carton Dimensions - 890*410*185mm
 Weight - 9.4kg

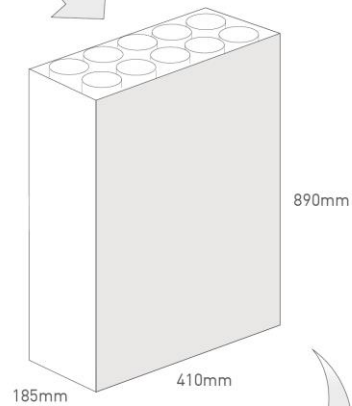

Pallet Dimensions 1200mm*1000mm*1495mm
 14 Cartons per Pallet
 2 Cartons per layer
 7 Layers

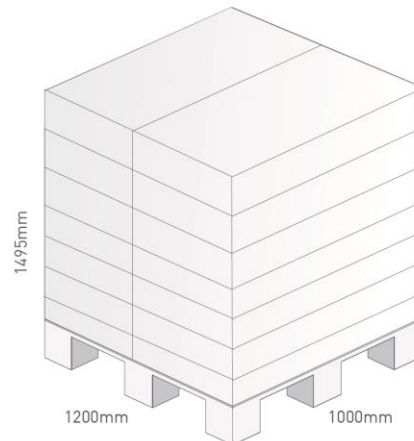

7. Antenna Installation Guide

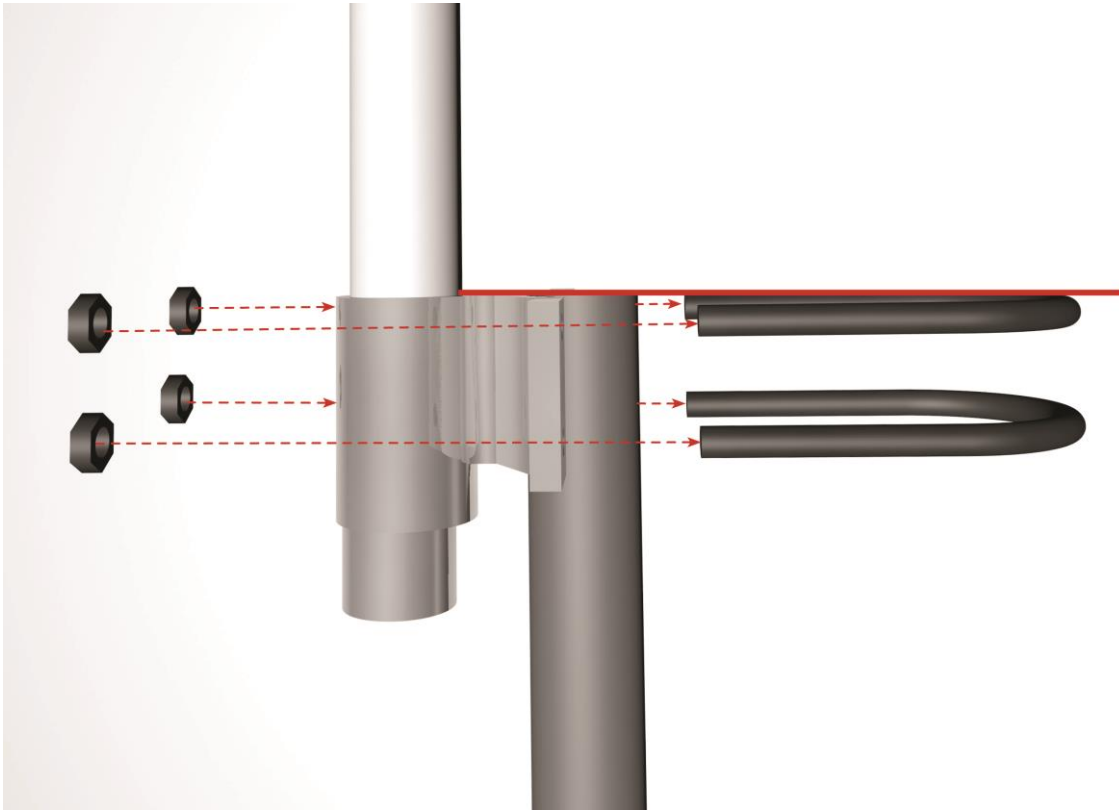

Taoglas makes no warranties based on the accuracy or completeness of the contents of this document and reserves the right to make changes to specifications and product descriptions at any time without notice. Taoglas reserves all rights to this document and the information contained herein.

Reproduction, use or disclosure to third parties without express permission is strictly prohibited.

Copyright © Taoglas Ltd.



Компания «ЭлектроПласт» предлагает заключение долгосрочных отношений при поставках импортных электронных компонентов на взаимовыгодных условиях!

Наши преимущества:

- Оперативные поставки широкого спектра электронных компонентов отечественного и импортного производства напрямую от производителей и с крупнейших мировых складов;
- Поставка более 17-ти миллионов наименований электронных компонентов;
- Поставка сложных, дефицитных, либо снятых с производства позиций;
- Оперативные сроки поставки под заказ (от 5 рабочих дней);
- Экспресс доставка в любую точку России;
- Техническая поддержка проекта, помощь в подборе аналогов, поставка прототипов;
- Система менеджмента качества сертифицирована по Международному стандарту ISO 9001;
- Лицензия ФСБ на осуществление работ с использованием сведений, составляющих государственную тайну;
- Поставка специализированных компонентов (Xilinx, Altera, Analog Devices, Intersil, Interpoint, Microsemi, Aeroflex, Peregrine, Syfer, Eurofarad, Texas Instrument, Miteq, Cobham, E2V, MA-COM, Hittite, Mini-Circuits, General Dynamics и др.);

Помимо этого, одним из направлений компании «ЭлектроПласт» является направление «Источники питания». Мы предлагаем Вам помощь Конструкторского отдела:

- Подбор оптимального решения, техническое обоснование при выборе компонента;
- Подбор аналогов;
- Консультации по применению компонента;
- Поставка образцов и прототипов;
- Техническая поддержка проекта;
- Защита от снятия компонента с производства.



Как с нами связаться

Телефон: 8 (812) 309 58 32 (многоканальный)

Факс: 8 (812) 320-02-42

Электронная почта: org@eplast1.ru

Адрес: 198099, г. Санкт-Петербург, ул. Калинина, дом 2, корпус 4, литера А.