



## ProxSense® IQS263B Datasheet

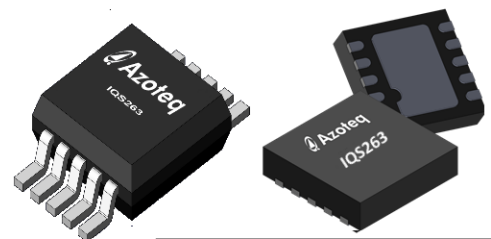
### 3 Channel Capacitive Touch and Proximity Controller with 8-bit Resolution Slider or Scroll Wheel

The **IQS263B** ProxSense® IC is a 3-channel projected (or self) capacitive proximity and touch controller with best in class sensitivity, signal to noise ratio and power consumption. Other features include automatic tuning for sense electrodes, internal reference capacitor and internal regulator to reduce total system cost.

#### Main Features

- 3 Self or Mutual Channel Capacitive Controller
- Configurable 8-bit 2/3 channel slider or 3 channel scroll wheel
- Up to 80Hz report rate
- On chip Movement Detection algorithm
- SAR compliance in mobile devices according to the IEC 62209-2 ed1.0 standard and the FCC standard (KDB 616217 – D04 SAR for laptop and tablets v01)
- Left and right flick gesture recognition
- Automatic adjustment for optimal performance (ATI)
- User selectable Proximity and Touch thresholds
- Long proximity range
- Automatic drift compensation
- Fast I<sup>2</sup>C Interface
- Event mode or Streaming modes
- Hibernation mode
- Low Power, suitable for battery applications
- Supply voltage: 1.8V to 3.6V
- <3µA Active sensing in LP mode
- <100µA full running current up to 40Hz report rate

RoHS2  
Compliant



IQS263B MSOP10 / DFN 10  
Representations only, not actual  
markings

#### Applications

- SAR detection for tablets and mobile phones
- SAR detection for wireless charging stations (operating frequency > 100MHz)
- SAR detection for USB dongle-type devices
- Sliders/Scroll wheels for remote controls
- Movement detection devices (anti-theft)
- Volume Control & Lid closure detection for laptops
- MP3 players
- Portable Electronics
- Wearable Electronics

#### Available Options

TA	MSOP10	DFN10 (3x3)
-20°C to 80°C	IQS263B	IQS263B



## Contents

1	INTRODUCTION .....	3
2	ANALOGUE FUNCTIONALITY.....	3
3	DIGITAL FUNCTIONALITY .....	3
4	PASSING THE SAR QUALIFICATION TESTING .....	4
5	HARDWARE CONFIGURATION .....	4
6	USER CONFIGURABLE OPTIONS.....	10
7	SLIDERS/WHEEL COORDINATE TO POSITION MAPPING.....	18
8	PROXSENSE <sup>®</sup> MODULE .....	22
9	COMMUNICATION .....	27
10	COMMUNICATION COMMAND/ADDRESS STRUCTURE .....	29
11	SPECIFICATIONS .....	41
12	PACKAGING INFORMATION .....	44
13	DEVICE MARKING .....	50
14	ORDERING INFORMATION .....	51

## Revision History

Version	Description	Date
1.00	First Release	August 2017
1.01	Second Release	November 2017
1.02	Third Release	December 2017
1.03	Fourth Release	March 2018
1.04	Fifth Release	October 2018
1.05	Sixth Release	August 2019



## Functional Overview

### 1 Introduction

The **IQS263B** is a 3 channel projected (or self) capacitive proximity and touch sensor featuring an internal voltage regulator and reference capacitor ( $C_s$ ).

The device has 4 possible pins for the connection of the sense electrodes, which consist of 3 Self electrodes, or 3 receivers and 1 transmitter. Three pins are used for serial data communication through the I<sup>2</sup>C™ compatible protocol, including an optional RDY pin. The transmitter pin can also be used as an I/O for output upon proximity detection when the device is used in Self capacitive mode.

The device automatically tracks slow varying environmental changes via various filters, detects noise and is equipped with an Automatic Tuning Implementation (ATI) to adjust the device for optimal sensitivity.

#### 1.1 Applicability

All specifications, except where specifically mentioned otherwise, provided by this datasheet are applicable to the following ranges:

- Temperature -20°C to +85°C
- Supply voltage ( $V_{DDHI}$ ) 1.8V to 3.6V

#### 1.2 Device Operation

With a normal activation (hand brought close) the output bit(s) will become active. These outputs will clear as soon as the action is reversed (hand taken away). In addition a separate movement output will become active when movement is detected according to a movement threshold. Movement may be detected before the normal touch threshold is crossed. Movement detection is done via a completely separate digital filter.

## 2 Analogue Functionality

CRX and CTX electrodes are arranged in a suitable configuration that results in a mutual

capacitance ( $C_m$ ) between the two electrodes. CTX is charged up to a set positive potential during a charge cycle which results in a negative charge buildup at CRX.

The resulting charge displacement is then measured within the **IQS263B** device through a charge transfer process that is periodically initiated by the digital circuitry. The capacitance measurement circuitry makes use of an internal reference capacitor  $C_s$  and voltage reference ( $V_{REF}$ ).

The measuring process is referred to as a conversion and consists of the discharging of  $C_s$  and  $C_x$  capacitors, the charging of  $C_x$  and then a series of charge transfers from  $C_x$  to  $C_s$  until a trip voltage is reached. The number of charge transfers required to reach the trip voltage is referred to as the Counts (CS) value.

The analogue circuitry further provides functionality for:

- Power On Reset (POR) detection.
- Brown Out Detection (BOD).
- Internal regulation provides for accurate sampling.

## 3 Digital Functionality

The digital processing functionality is responsible for:

- Managing BOD and WDT events.
- Initiation of conversions at the selected rate.
- Processing of CS and execution of algorithms.
- Monitoring and execution of the ATI algorithm.
- Signal processing and digital filtering.
- Detection of PROX and TOUCH events.
- Managing outputs of the device.
- Managing serial communications.



## 4 Passing the SAR Qualification Testing

The IQS263B offers a movement monitoring algorithm, to help the host controller distinguish between long term user activations and stuck conditions.

For design information on passing the SAR qualification testing with Azoteq movement based sensors, please see the application note: [“AZD073 SAR qualification with Azoteq movement-based sensors.”](#)

## 5 Hardware Configuration

The IQS263B can be configured to charge in Self- or Projected-Capacitive mode through the memory map by the host controller. The IQS263B is default in Self Capacitive mode, and can be set to Projected-Capacitive mode by setting the “Proj Mode” bit in [Register 0x01](#), byte 0.

In **Self Capacitive** mode, the IQS263B has 3 channels. It can be used as 3 discrete buttons OR as a slider. It will also have a proximity output available.

In **Projected-Capacitive** mode, the IQS263B has 3 channels. It can be used as 3 discrete buttons OR a slider but no proximity output will be available.

### 5.1 IQS263B Pin Out

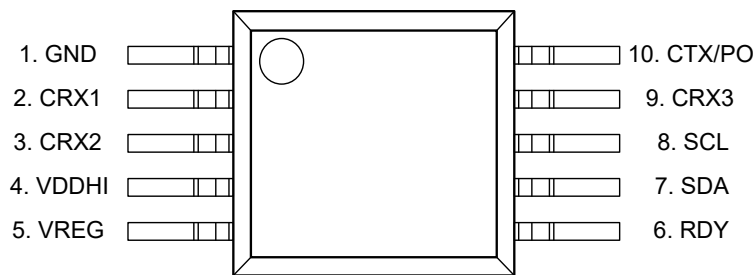


Figure 5.1 IQS263B Pin out in MSOP-10.

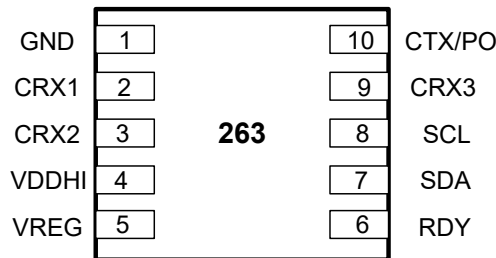


Figure 5.2 IQS263B Pin out in DFN10.

Table 5.1 IQS263B MSOP-10 & DFN10 Pin-outs.

Pin	Self-Capacitive	Projected-Capacitive	Function
1	GND	GND	Ground
2	CX1	Rx1	Sensor Electrode
3	CX2	Rx2	Sensor Electrode
4	VDDHI	VDDHI	Power Supply
5	VREG	VREG	Regulated Output
6	RDY	RDY	Communication Interrupt
7	SDA	SDA	Serial Data
8	SCL	SCL	Serial Clock
9	CX3	Rx3	Sensor Electrode



Pin	Self-Capacitive	Projected-Capacitive	Function
10	PO	Tx	Prox Out/Sensor Electrode

## 5.2 Reference Design

### 5.2.1 Projected Schematic

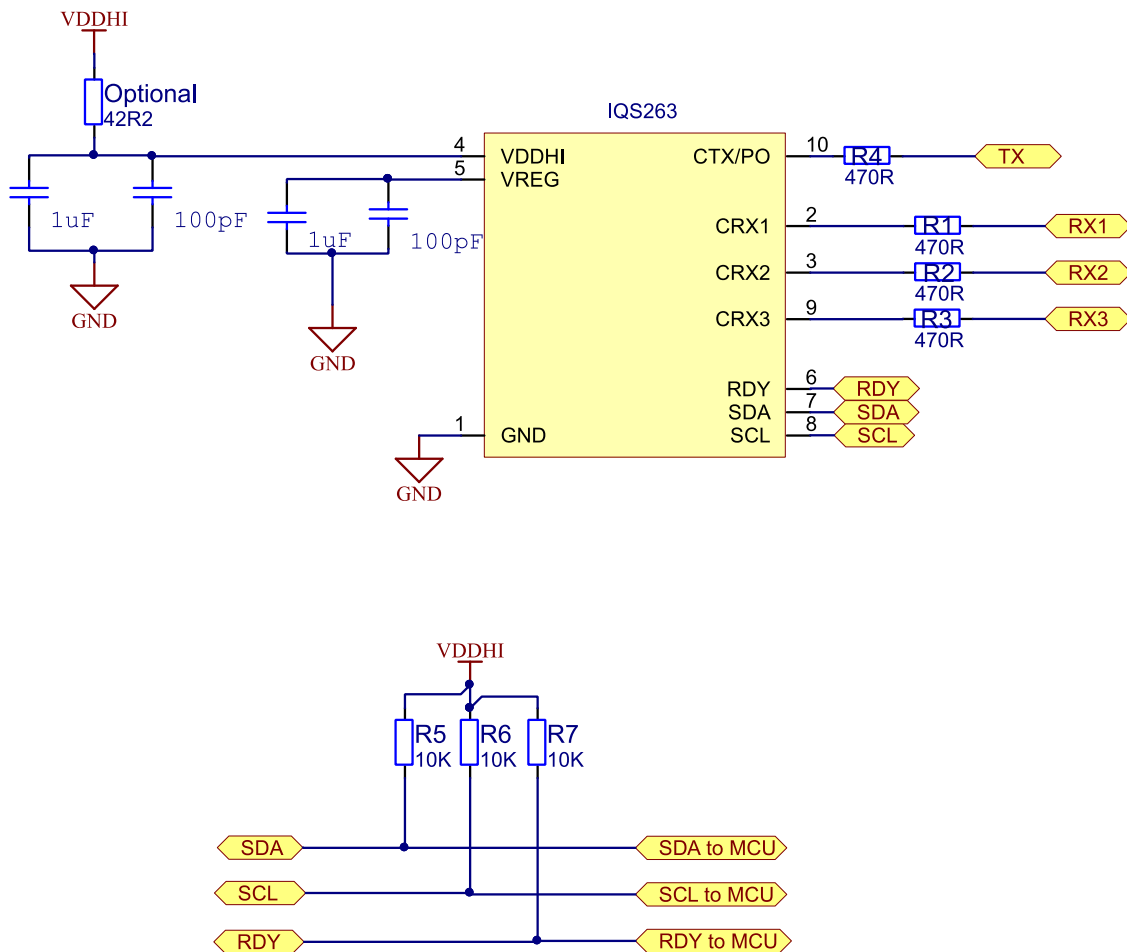


Figure 5.3 IQS263B projected capacitive reference design.

### 5.2.2 Projected Electrodes

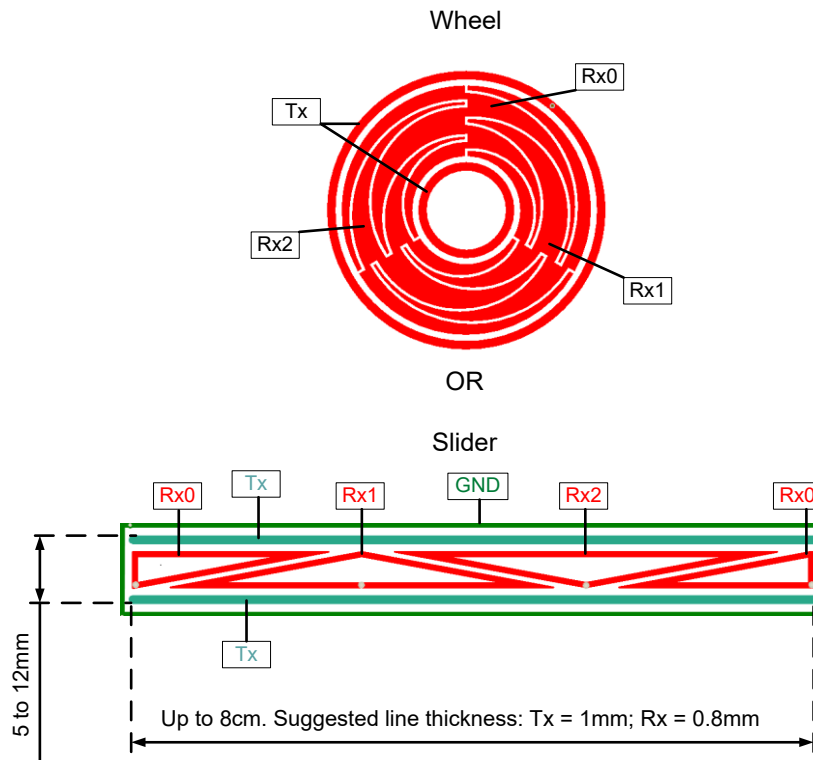


Figure 5.4 Example layout of projected wheel OR slider that wraps around – 0 to 191 coordinates available.

### 5.2.3 Example Routing

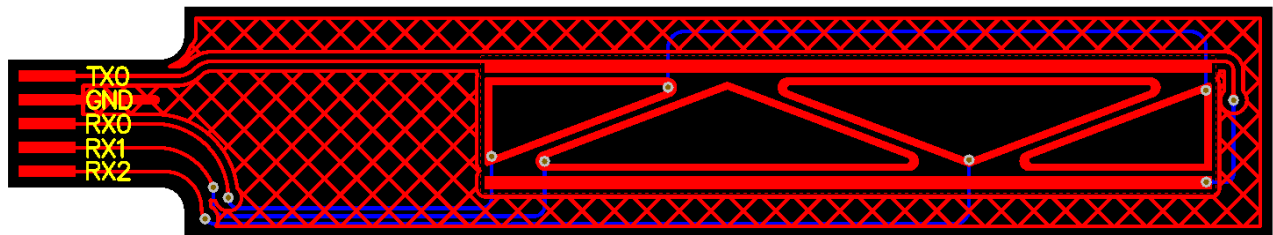


Figure 5.5 Example routing of a projected slider. GND on top layer shields the Rx lines from the user on the bottom layer.

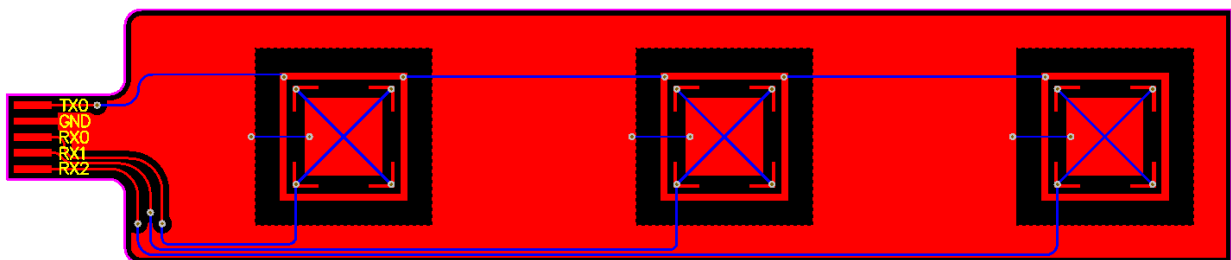


Figure 5.6 Example routing of 3 discrete buttons. These buttons are suggested for application requiring high noise immunity.

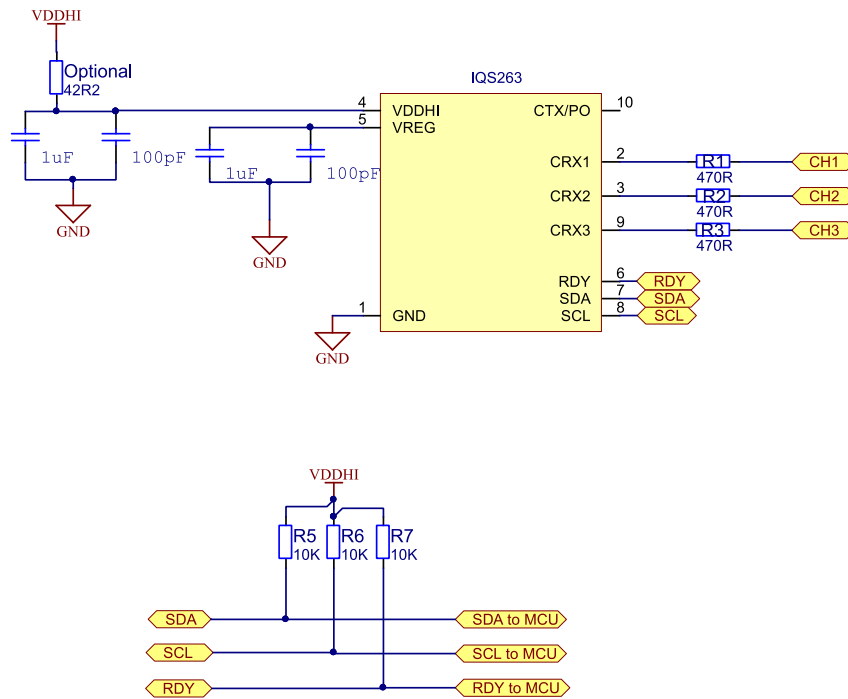


### 5.2.4 Projected Setup

For both the wheel and slider shown in Figure 5.4 the **IQS263B** slider setup in ProxSettings1 must be set to the “Wheel” selection (Bit3:2 as 10).

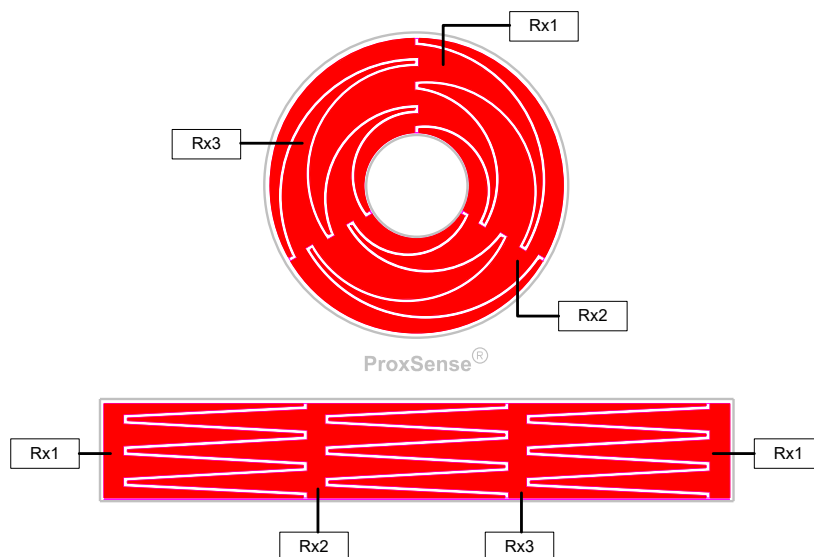
The slider setup of the **IQS263B** in ProxSettings1 for the 3 discrete keys such as shown in Figure 5.6 can be set to “3CH Slider” selection (Bit3:2 as 11). Since the buttons have no interleaving, the coordinate tracking will not be linear. However, recognising flick events will still be achieved.

### 5.2.5 Self Schematic

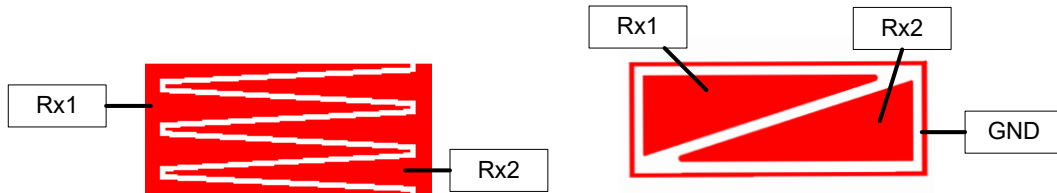


**Figure 5.7** IQS263B self-capacitive reference design.

### 5.2.6 Self Electrodes



**Figure 5.8** Example of a 3 Channel Self capacitive wheel and slider. Suggested gaps between electrodes  $\geq 0.8\text{mm}$ .



**Figure 5.9** Examples of 2 Channel Self capacitive sliders. Suggested gaps between electrodes  $\geq 0.8\text{mm}$ .

### 5.2.7 Self Setup

For both the wheel and slider shown in Figure 5.8 the **IQS263B** slider setup in ProxSettings1 must be set to the “Wheel” selection (Bit3:2 as 10).

For the slider shown in Figure 5.9 the **IQS263B** slider setup in ProxSettings1 must be set to the “2CH slider” selection (Bit3:2 as 01).

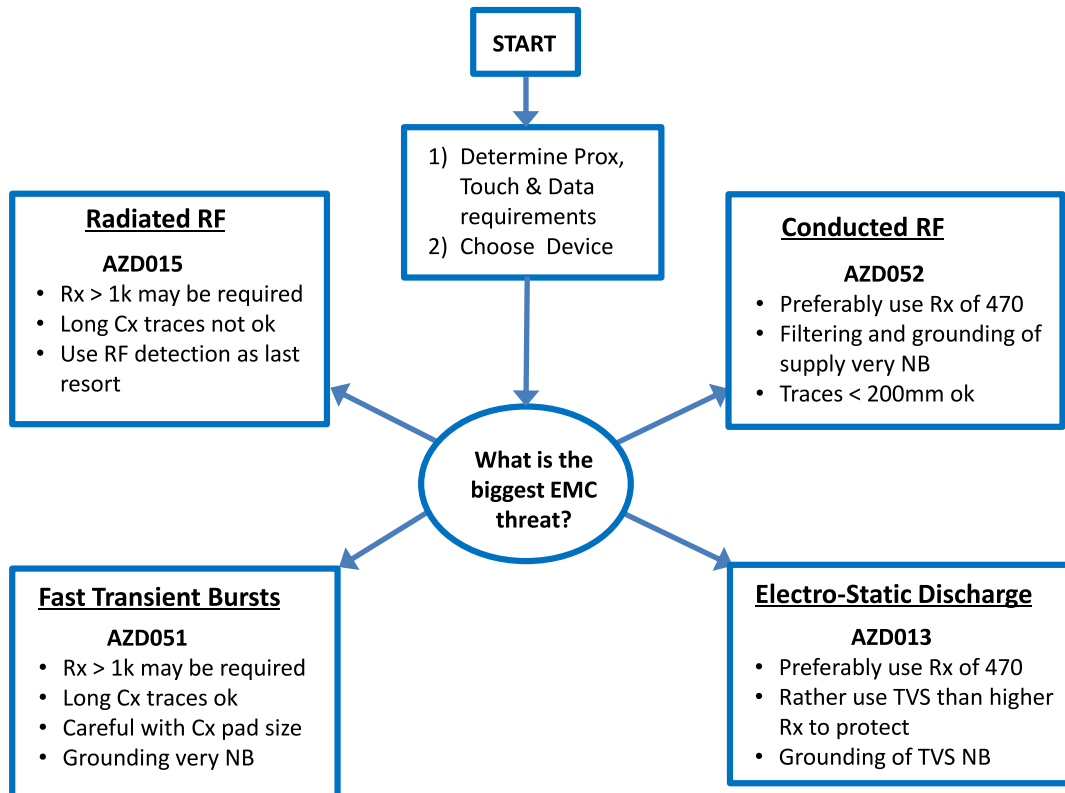
## 5.3 Power Supply and PCB Layout

Azoteq IC's provide a high level of on-chip hardware and software noise filtering and ESD protection (refer to application note “**AZD013 – ESD Overview**”). Designing PCB's with better noise immunity against EMI, FTB and ESD in mind, it is always advisable to keep the critical noise suppression components like the de-coupling capacitors and series resistors in **Figure 5.3** as close as possible to the IC. Always maintain a good ground connection and ground pour underneath the IC. For more guidelines please refer to the relevant application notes as mentioned in **Section 5.4**.

Where a system level ESD strike is found to cause the IC to go into ESD induced latch-up, it is suggested that the supply current to the **IQS263B** IC is limited by means of a series resistor that could limit the maximum supply current to the IC to  $<80\text{mA}$ .



## 5.4 Design Rules for Harsh EMC Environments



➤ **Applicable application notes: AZD013, AZD015, AZD051, and AZD052.**

## 5.5 High Sensitivity

Through patented design and advanced signal processing, the device is able to provide extremely high sensitivity to detect proximity. This enables designs to detect proximity at distances that cannot be equaled by most other products. When the device is used in environments where high levels of noise or floating metal objects exist, a reduced proximity threshold is proposed to ensure reliable functioning of the sensor. The high sensitivity also allows the device to sense through overlay materials with low dielectric constants, such as wood or porous plastics.

For more guidelines on the layout of capacitive sense electrodes, please refer to application note **AZD008**, available on the Azoteq web page: [www.azoteq.com](http://www.azoteq.com).



## 6 User Configurable Options

The **IQS263B** requires configuration by a master/host controller or MCU. The user needs to select the number of channels and corresponding touch and proximity thresholds.

### 6.1 Setup

#### 6.1.1 Self and Projected Modes

The **IQS263B** can function as a Self or Projected capacitive controller, depending on the application requirement. The **IQS263B** is default in Self capacitive mode. Pre-configured devices can be ordered for projected mode, or the user can select the operation mode as projected during initialization by setting the “Proj Mode” bit in the [System Flags register \(0x01H; byte 0\)](#).

#### 6.1.2 Global Filter Halt

By default the **IQS263B** implements a global filter halt. This realizes that all LTA filters are frozen upon any proximity or touch detection. This optimizes sensitivity by reducing the risk of desensitizing of touch channels during user operation, especially for slider functions.

It is, however, possible to disable the global filter halt, whereby each channel will halt its own LTA upon a detection of an undebounced event on that channel. To disable the global filter halt, the user must set the “Ind Halt” bit in the [System Flags register \(0x01H; byte 0\)](#).

### 6.2 ProxSetting0

#### 6.2.1 Disable ATI

The **IQS263B** has the ability to automatically retune sensor electrodes when the counts drift outside a pre-defined [ATI band](#). This allows the **IQS263B** to keep optimal sensitivity during different environment. To disable the feature, the “ATI OFF” bit needs to be set in the [ProxSettings0 register \(0x09; byte 0\)](#).

Disabling this feature only disables the automatic retuning; the MCU can at any time still force retuning with the [Redo-ATI](#) command.

#### 6.2.2 Partial ATI

If it is required to have the ATI time reduced, the **IQS263B** can use partial ATI by setting the “ATI Partial” bit in the [ProxSettings0 register \(0x09; byte 0\)](#). The designer must also specify the sensitivity multiplier (option 1 to 4) as the **IQS263B** will only calculate the compensation multiplier and compensation. The Partial ATI option reduces start-up and re-tuning times, but does require the designer to verify that the base values achieved are within the desired range.

#### 6.2.3 ATI Band

The user has the option to select the re-tuning band as  $\frac{1}{4}$  of the ATI target (default is  $\frac{1}{8}$  of the ATI target) if it is desired to have a wider range for the counts to drift with environmental change before the device retune the electrodes. The wider band is achieved by setting the “ATI BAND” bit in the [ProxSettings0 register \(0x09; byte 0\)](#).

#### 6.2.4 Stream ATI

In order to facilitate faster start-up and re-tuning times, the communication windows are stopped during ATI on the **IQS263B**. If the designer would like to be able to read data after every charge cycle during ATI, the communication can be enabled by setting the “Stream ATI” bit in the [ProxSettings0 register \(0x09; byte 0\)](#). A communication window can still be forced by the MCU with a RDY handshake (pulling the RDY line low) at any time even if the “Stream ATI” bit is not set.

#### 6.2.5 Oscillator

The **IQS263B** response times can be increased (at the cost of higher current consumption) by setting the internal oscillator at 4MHz (default 2MHz). The faster speed is enabled by setting the



“4MHz” bit in the [ProxSettings0 register \(0x09; byte 0\)](#).

### 6.2.6 Redo-ATI

The **IQS263B** can be forced to ATI at any time, regardless of present events. To force retuning set the “Redo ATI” bit in the [ProxSettings0 register \(0x09; byte 0\)](#). The “Redo ATI” bit will automatically clear after having been set.

### 6.2.7 Reseed

The **IQS263B** LTA filters can be reseeded to the count values at any time to clear any output event. If count values are outside the ATI band, retuning will be triggered. To reseed set the “Reseed” bit in the [ProxSettings0 register \(0x09; byte 0\)](#). The “Reseed” bit will automatically clear after having been set.

Setting the Reseed bit will shift all LTA filters to a value of  $LTA_{new} = CS + 8$  ( $CS - 8$  for Self). The LTA will then track the CS value until they are even.

Performing a reseed action on the LTA filters, will effectively clear any proximity and/or touch conditions that may have been established prior to the reseed call.

### 6.2.8 Force Halt

The user has the option to halt the LTA to avoid any reseed or re-tuning events from taking place. This can be used in situations where the counts are expected to go in the wrong direction as a result of a controlled action in the application. To freeze the LTA filters set the “Force Halt” bit in the [ProxSettings0 register \(0x09; byte 0\)](#).

## 6.3 ProxSettings1

### 6.3.1 WDT Disable

The WDT (watchdog timer) is used to reset the IC if a problem (for example a voltage spike) occurs during communication. The WDT will time-out (and thus reset the device) after  $t_{WDT}$  if no valid communication occurred during this time.

The WDT can be disabled during development by setting the “WDT Off” bit in

the [ProxSettings1 register \(0x09; byte 1\)](#). It is not recommended to disable the WDT for production.

### 6.3.2 Event Mode

By default the device operates in full streaming mode. There is an option for an event-driven I<sup>2</sup>C communication mode (also called “Event Mode”), with the RDY pin indicating a communication window ONLY after a prescribed event has occurred.

These events include:

- Flicks (left and/or right)
- Tap
- Movement
- ATI
- Slider
- Touch
- Proximity

The RDY pin will indicate events in the following manner:

1. **Flick/Swipe Detected:** Single RDY low on flick left or right
2. **Tap Detected:** Single RDY low
3. **Movement occurring:** Single RDY low on movement event
4. **ATI:** RDY low on ATI start & again on ATI completing
5. **Slider or Wheel:** RDY pin low after completion of every charge cycle while a touch remains detected on a wheel/slider channel.
6. **Touch:** RDY low on each touch entry and exit occurring.
7. **Prox:** RDY low on entry and exit

If the wheels/sliders are enabled, the device will stream data continuously (after every charge cycle) when a touch is present on one of the wheel/slider channels, even if Event Mode is enabled.

Event Mode can be enabled by setting the “Event Mode” bit in the [ProxSettings1 register \(0x09; byte 1\)](#).



Note: The device is also capable of functioning **without** a RDY line on a polling basis.

### 6.3.3 LTA Beta

The speed at which the LTA will follow the counts when no event is present (no filter halt) can be changed by adjusting the beta values for the LTA filter. Four options are available by setting the “LTA Beta” bits in the [ProxSettings1 register \(0x09; byte 1\)](#).

### 6.3.4 Slider

The **IQS263B** can be used to do 8-bit coordinate calculations to implement a slider or a scroll wheel. The wheel requires all 3 touch channels, where the slider can be selected as a 2 (channel 1 & 2 required) or 3 channel slider. By default, no calculations are done. To enable a wheel or slider, set the “Slider” bits in the [ProxSettings1 register \(0x09; byte 1\)](#). When using the wheel setting, Deltas are not available in register 0x06.

### 6.3.5 Count Filter

The count filter is implemented to provide better stability of Counts (CS) in electrically noisy environments.

The filter also enforces a longer minimum sample time for detecting proximity events on CH0, which will result in a slower response rate when the device enters low power modes. The filter can be disabled.

The count filter is implemented on all channels, to aid in the slider coordinate calculations, but touch events are (by default) determined on unfiltered count values.

The count filter can be disabled, or the speed (amount of filtering) adjusted by setting the “CF” bits in the [ProxSettings1 register \(0x09; byte 1\)](#).

## 6.4 ProxSettings2

### 6.4.1 Output Pin

The **IQS263B** when operating in Self Capacitive mode has an output/input (PO) pin available (pin 10). As output (active

low), it can be set to trigger on proximity, touch (on channel 1) or movement events. As input, it can be used as a synchronization pin to be used as a ZC (zero cross input) for AC applications. To switch between input and output set the “OUT” bits in the [ProxSettings2 register \(0x09; byte 2\)](#). When used as an input pin, the **IQS263B** will monitor pin 10, and wait for a change in state (either high to low or low to high), before sensing is initiated. This will happen before each cycle of scanning all the keys.

### 6.4.2 Movement

The **IQS263B** can implement a movement filter on CH0 or CH3. Movement detection will clear/restart the filter halt timer. Movement will be sensed in both directions. By monitoring movement (of the count values), the host controller can distinguish between user activation and stuck conditions.

The host could choose to implement movement on CH3 or CH0, by setting the “Movement” bits in the [ProxSettings2 register \(0x09; byte 2\)](#).

### 6.4.3 Wake 2 Directions

The **IQS263B** has the ability to wake from low power in both directions of count movement (of the proximity threshold). This could be used to sense release events from low power mode. To enable sensing in both directions, set the “Wake

Release” bit in the [ProxSettings2 register \(0x09; byte 2\)](#).

### 6.4.4 Wheel/Slider Filter

If the **IQS263B** implements a wheel or slider, the coordinate filter can be disabled for faster output (if the layout and environment allows stable output). To disable the coordinate filter set the “Wheel Filter” bit in the [ProxSettings2 register \(0x09; byte 2\)](#).

### 6.4.5 Force Sleep

MCU can command a sleep during any situation. This sleep can be cancelled by



the MCU, or will automatically clear when the LP channels counts differs more than the proximity threshold from the LTA (in any direction if [Wake 2 Directions](#) is enabled). To force the **IQS263B** into low power mode set the “Force Sleep” bit in the [ProxSettings2 register \(0x09; byte 2\)](#).

#### 6.4.6 Sleep Halt

The **IQS263B** can go back into low power mode rather than reseed or re-tune (ATI) when a stuck condition or prolonged event is present. A low power time greater than zero need to be specified for this setting. To set up the sleep on halt time out feature set the “Sleep Halt” bit in the [ProxSettings2 register \(0x09; byte 2\)](#).

### 6.5 ProxSettings3

#### 6.5.1 Touch Debounce

The **IQS263B** can set the touch output on 4 samples where the delta exceeds the touch threshold (default 2 samples). A lower debounce will speed up the response rate, especially for applications using the filtered counts for touch output. To set the touch debounce to 4 set the “Touch Debounce” bit in the [ProxSettings3 register \(0x09; byte 3\)](#).

#### 6.5.2 Off Mode

The **IQS263B** has the option to switch the device off during inactive states of operation. The device will wake up again with activity on the SDA line. Enabling “Off Mode” switches the device off internally, as a result, no register values are maintained. Upon exiting “Off Mode” the standard startup routine is followed, the “Show Reset” bit is set and the device must be re-initialized. This is suitable for applications that require no device operation during defined operation states and is useful when the master has no control over the VDDHI line of the **IQS263B**. To switch to off mode set the “Off Mode” bit in the [ProxSettings3 register \(0x09; byte 3\)](#).

#### 6.5.3 Projected Bias

The **IQS263B** has the option to change the bias current of the transmitter during

projected sensing mode. A larger bias current is required when using larger electrodes, but will also increase the IC power consumption. The bias current is default on 10µA, and can be changed to 20µA. To select 20 µA set the “Proj Bias” bit in the [ProxSettings3 register \(0x09; byte 3\)](#).

#### 6.5.4 Float CX

During the charge transfer process, the channels (CX electrodes for Self or Rx electrodes for projected) that are not being processed during the current conversion are effectively grounded to decrease the effects of noise-coupling between the sense electrodes. Grounding these traces is useful in applications with long tracks between IC and sense electrode.

There is the option to float the CX (or Rx) lines in between charging. This is particularly useful for applications with self-capacitive wheels/sliders with thick overlays, where more sensitivity is required, or in application that need to avoid false triggers from water on the overlays. To float channels set the “Float Cx” bit in the [ProxSettings3 register \(0x09; byte 3\)](#).

#### 6.5.5 Halt Charge

The charging sequence of the **IQS263B** can be halted on command. This function is useful for applications where the charge transfer sequence on all channels must be stopped for a period of time while maintaining read/write access to the **IQS263B**. To enable halt charge mode, set the “Halt Charge” bit in the [ProxSettings3 register \(0x09; byte 3\)](#).

#### 6.5.6 Turbo Mode

The **IQS263B** device by default performs conversions (charge transfers or sensing) as fast as processing and communication allows. Disabling Turbo Mode will yield in a fixed sampling period ( $t_{\text{sample}} = 40/80\text{Hz}$ ) that will increase the effectiveness of the count filter, but will reduce response rate. To disable turbo mode set the “Turbo



Mode” bit in the [ProxSettings3 register \(0x09; byte 3\)](#).

### 6.5.7 Filtered Touches

The **IQS263B** offers applications that are sensitive to touch detection and releasing upon soft touch events the option to trigger touch outputs on filtered count values. This improves stability, but could reduce response rate. To enable the filtered touches feature set the “Filtered Touches” bit in the [ProxSettings3 register \(0x09; byte 3\)](#).

### 6.5.8 Charge Transfer Frequency

The **IQS263B** can reduce the charge transfer frequency for applications that require extra sensitivity (for example very thick overlays). The charge transfer frequency can be halved (for both Self and Projected operation) by setting the “Xfer” bit in the [ProxSettings3 register \(0x09; byte 3\)](#).

## 6.6 Active Channels

The **IQS263B** can be configured to have up to 3 active touch channels (CH1-CH3) with one additional proximity channel (CH0). By default CH0 is a distributed proximity channel, comprised of charging all the channels together in one timeslot.

## 6.7 Proximity Threshold

A proximity threshold for channel 0 can be selected for the application, to obtain the desired proximity trigger level. The proximity threshold is selectable between 1 (most sensitive) and 255 (least sensitive) counts. These threshold values (i.e. 1-255) are specified in Counts (CS) in the [Thresholds register \(0x0A; byte 0\)](#). The default proximity threshold is four counts.

## 6.8 Touch Thresholds

A touch threshold for each channel can be selected by the designer to obtain the desired touch sensitivity and is selectable between 1/256 (most sensitive) to 255/256

(least sensitive). The touch threshold is calculated as a fraction of the Long-Term Average (LTA) given by,

$$T_{THR} = x/256 \times LTA$$

With lower target values (therefore lower LTA's) the touch threshold will be lower and vice versa.

Individual touch thresholds can be set for each channel, by writing to the [Thresholds register \(0x0A; byte 1\)](#) for channel 1, byte 2 for channel 2 and byte 3 for channel 3. The default touch threshold is 16/256 times the LTA.

## 6.9 Adjustable Report Rate

The **IQS263B** can adjust its report rate from to 80Hz ([4Mhz oscillator](#)) to 40Hz (2MHz). The **IQS263B** can also disable [turbo mode](#), which will yield a fixed sampling period, to optimize the count filter operation.

## 6.10 Gestures

The **IQS263B** implements a tap gesture on the slider or scroll wheel. Left and right flick gestures are only implemented on the slider (no double tap). For flick events, one of the [slider options](#) should be active.

### 6.10.1 Tap

The **IQS263B** implements an adjustable TAP timer for configurable tap recognition. The timer is started once a touch event is recognised. A tap event will be registered if the touch event is released (cleared) before the timer reaches the adjustable tap time. The tap time can be adjusted in the [Gesture Timer register \(0x0C, byte 0\)](#).

### 6.10.2 Flicks

The **IQS263B** implements an adjustable Flick recognition on the slider setups. The user has the option to specify the flick threshold in the [Gesture Timer register \(0x0C, byte 1\)](#) to set the amount that the coordinates must be adjusted by the user before the flick event is set. There is also



the option to adjust the time in which the coordinate must move by setting the flick timer in the [Gesture Timer register \(0x0C, byte 2\)](#).

## 6.11 Halt times

The LTA filter for all channels will halt on proximity or touch events. The halt time is specified through the memory map in terms of number of samples (sampling of all active channels) by specifying a value in the [Thresholds register \(0x0A; byte 6\)](#). The halt time is calculated as this value times 50. Writing FF will result in “Always Halt” while 00 will be seen as never halt. The default value is 20, therefore the halt time will be

$$t_{HALT} = 20 \times 50$$

which is 1000 samples. The halt timer clears on any new touch, proximity or slider activity.

## 6.12 Power Modes

### 6.12.1 LP Modes

The **IQS263B** IC has a configurable low power mode, specifically designed to reduce current consumption for low power and battery applications. When designing for low power operation, the  $V_{REG}$  capacitors should ensure that  $V_{REG}$  does not drop more than 50mV during low power operations.

The power modes are implemented around the occurrence of a charge cycle every  $t_{LP}$  seconds. The value of  $t_{LP}$  is determined by the custom ( $LP_{value}$ ) value between 1 and 255, multiplied by 16ms. The  $LP_{value}$  can be specified by writing to the [Timings register \(0x0B; byte 0\)](#). It is suggested not to exceed  $LP_{value} = 32$  (512ms) as the reduction in current consumption is negligible, response time becomes notable slower, and special attention needs to be

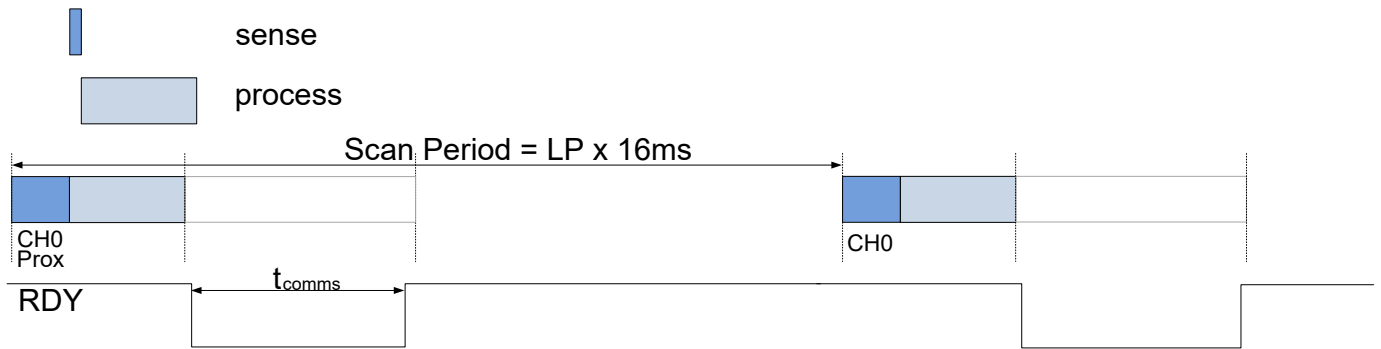
paid to  $V_{REG}$  capacitor design to ensure stable operation. Only CH0 is charged during LP, and is forced active (CH0 cannot be disabled). The other active channels will be periodically charged to keep their LTA filter values up to date.

Lower sampling times yield significantly lower power consumption (but also decreases the response time of the first event).

NOTE: While in any power mode the device will zoom to Boost Power (BP) mode whenever the condition  $(CS - LTA)^1 > PROX\_TH$  or  $TOUCH\_TH$  holds, indicating a possible proximity or touch event. This improves the response time. The device will remain in BP mode for 4 seconds and then return to the selected power mode. The Zoom function allows reliable detection of events with counts being produced at the BP rate. The LP charge cycle timing is illustrated in **Figure 6.1**.

---

<sup>1</sup> CS-LTA in Projected mode. LTA-CS in Self capacitive sensing mode.



**Figure 6.1 IQS263B Charge Cycle Timing in Low Power Mode.**

**Table 6.1 Typical Timings**

Typical timings of IQS263B in Low Power		
$t_{sense}$	1.1	ms
$t_{process}$	1.9	ms
$t_{comms}$	Application specific	ms
Scan Period	Should not exceed 512ms	





## 6.13 Base Value

The **IQS263B** has the option to select the base value of each channel individually during the Full ATI algorithm. This provides the user with another option to select the sensitivity of the **IQS263B** without any changes required in the hardware (CRX/CTX sizes and routing, etc).

The base values are set by writing to the [Multipliers register \(0x07; bytes 4 and 5\)](#). There are 16 different options to choose from. To choose a custom base value, select [partial ATI](#).

The base value influences the overall sensitivity of the channel and establishes a base count from where the ATI algorithm starts executing. A lower base value will typically result in a higher sensitivity of the respective channel, as lower multipliers will be selected, and more compensation would be required.

## 6.14 Target Value

The default target value of the **IQS263B** is 384 counts for the touch channels and 512 counts for the proximity channel.

The target values are calculated by multiplying the value in the [Timings & Targets register \(0x0B; byte 1\)](#) for channel

1 to channel 3 and byte 2 for channel 0 by 8.

**Example:** CH0 target = Register Value x 8  
= 64(default) x 8 = 512.

## 6.15 Additional Features

### 6.15.1 Force Halt

The Force Halt bit can be set to halt all current LTA values and prevent them from being adjusted towards the CS values.

Setting this bit overrides all filter halt settings and prevents the device from performing re-ATI events in cases where the CS values persist outside the ATI boundaries for extended periods of time. Reseed will also not be possible.

### 6.15.2 Halt Timeout Reseed Block

After the halt timer times out upon an event, the **IQS263B** will reseed all channels and possibly redo ATI if any counts are outside the allowed band. The user has the option to block this reseed on any of the touch channels (not CH0) allowing that channel(s) to keep its output state and effectively have an always halt condition. Note that other channels could drift outside the ATI band, but no ATI will take place if a channel is halted in this way. To set any combination of channels up for this state, select the corresponding bits in the [Halt Timeout Reseed Block register \(0x0A, byte 5\)](#).

## 7 Sliders/Wheel Coordinate to Position Mapping

The coordinate mapping from user finger positions given in this section is applicable to both Self- and Projected Capacitive sensing, even though examples of both will not be shown.

The absolute coordinate is only calculated when the IQS263B is in “Wheel” mode. This is done by setting Bits (3:2) in [ProxSettings1 \(0x09; Byte 1\)](#) to 0b10. For “2CH Slider” mode (0b01) and “3CH Slider” mode (0b11) only the relative coordinate is calculated. Sliders can, however, be used in “Wheel” mode to enable an absolute coordinate calculation, see section 7.4 for more details.

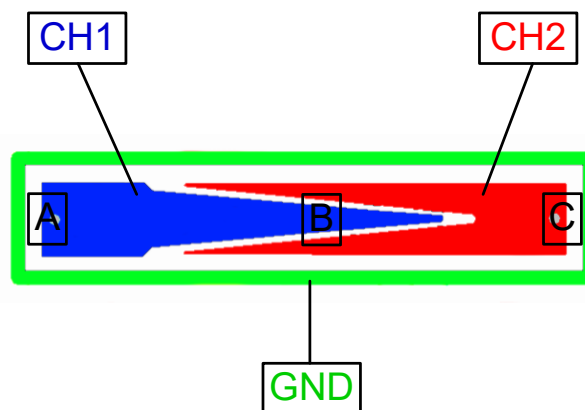
### 7.1 Two (2) Channel Slider

The 2-channel slider is recommended for applications requiring only the relative coordinate and/or the flick event. The 2 channel slider is not optimal for absolute coordinate values, therefore, the absolute coordinate is not calculated in this mode and reading the Wheel 1 Low byte at the [Wheel Coordinates \(0x02; Byte 0\)](#) address will return a value of 0. Reading the Relative Coordinate Low and Relative Coordinate High bytes will return the relative coordinate value as normal.

If an absolute coordinate is required from a 2-channel slider, it can easily be calculated by reading the [Deltas \(0x06\)](#) for channel 1 and 2 and applying the following formula:

$$Coordinate = \frac{(0 \cdot \Delta_1) + (max \cdot \Delta_2)}{(\Delta_1 + \Delta_2)} \quad eq. 7.1$$

Where “max” is a user defined value designating the highest possible coordinate value on the slider. Figure 7.1 shows the channel numbers and finger positions for the main definable positions where channels overlap on a 2 channel slider.



**Figure 7.1** Finger positions for coordinate mapping shown on a 2 channel slider.

Table 7.1 shows the approximate coordinate that equation 7.1 will produce for the finger positions shown in Figure 7.1.

**Table 7.1** 2CH slider coordinate mapping.

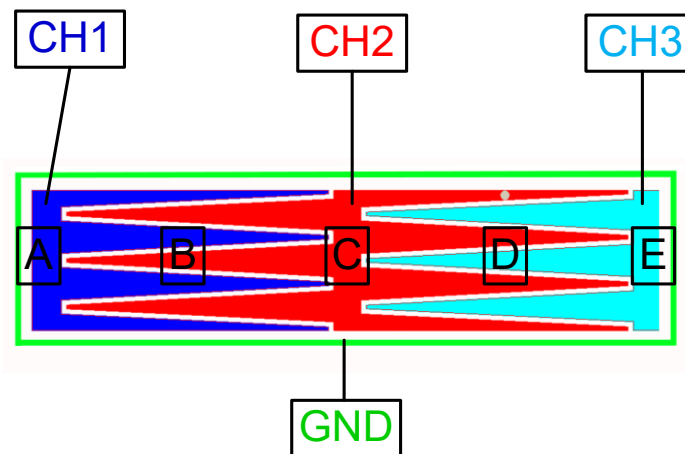
Positions	Coordinates
A	0
A to B	1 to $[(max/2) - 1]$
B	$max/2$
B to C	$[(max/2) + 1]$ to $[max - 1]$
C	$max$

## 7.2 Three (3) Channel Slider

The 3 channel slider is ideal for applications requiring flick events and a relative coordinate. Once again, the absolute coordinate is not calculated for the 3 channel slider. However, the MCU can easily calculate the absolute coordinate by reading the [Deltas \(0x06\)](#) and using the following formula:

$$Coordinate = \frac{(0 \cdot \Delta_1) + ((max/2) \cdot \Delta_2) + (max \cdot \Delta_3)}{(\Delta_1 + \Delta_2 + \Delta_3)} \quad eq. 7.2$$

Where “max” is a user defined value designating the highest possible coordinate value on the slider. Figure 7.2 shows the channel numbers and finger positions for the main definable positions where channels overlap on a 3 channel slider.



**Figure 7.2** Finger positions for coordinate mapping shown on a 3-channel slider.

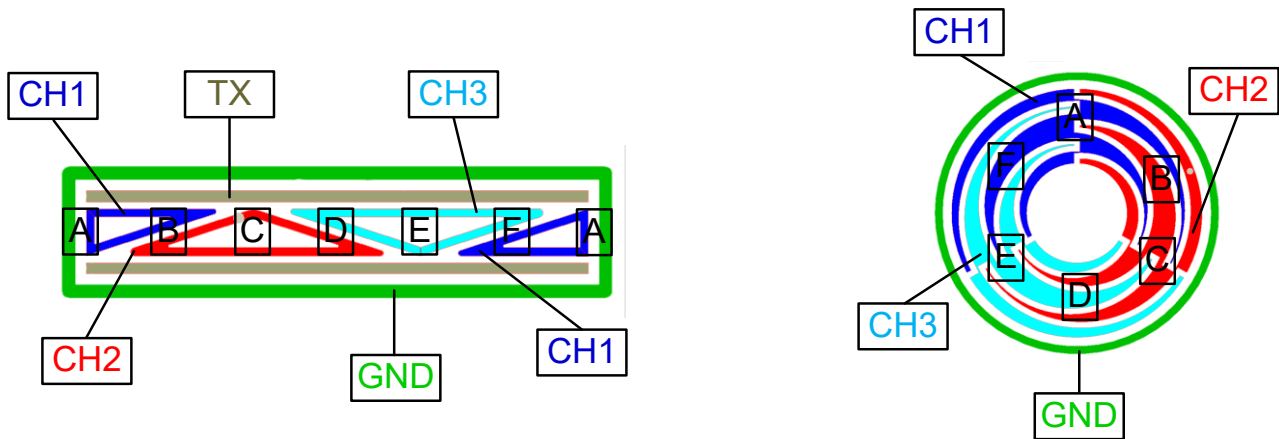
Table 7.2 shows the approximate coordinate that equation 7.2 will produce for the finger positions shown in Figure 7.3.

**Table 7.2** 3CH slider coordinate mapping.

Positions	Coordinates
A	0
A to B	1 to [(max/4) - 1]
B	max/4
B to C	[(max/4) + 1] to [(max/2) - 1]
C	max/2
C to D	[(max/2) + 1] to [(3/4 max) - 1]
D	3/4 max
D to E	[(3/4 max) + 1] to [max - 1]
E	max

### 7.3 Wheel / Wrap around Slider

In “Wheel” mode the **IQS263B** will calculate the coordinate position automatically, the MCU can then simply read the value from Wheel 1 Low byte, [Wheel Coordinates \(0x02; Byte 0\)](#). Figure 7.3 shows the channel numbers and finger positions for the main definable positions where channels overlap on a wraparound slider and wheel.



**Figure 7.3** Finger positions for coordinate mapping shown on a wheel and wrap around slider.

Table 7.3 shows the coordinate that the **IQS263B** will report for the finger positions shown in Figure 7.3.

**Table 7.3** Wrap around slider or wheel coordinate mapping.

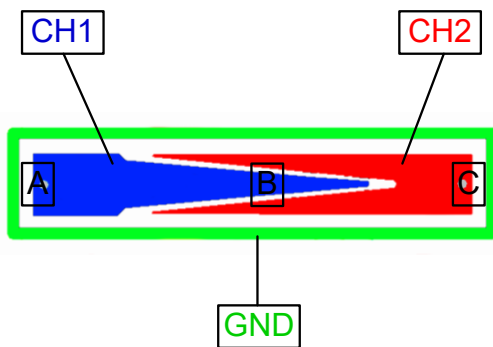
Positions	Coordinates
A	0
A to B	1 to 31
B	32
B to C	33 to 63
C	64
C to D	65 to 96
D	96
D to E	97 to 127
E	128
E to F	129 to 159
F	160
F to A	161 to 191

As seen from figure 7.3 and table 7.3, the coordinate value increases linearly from a minimum value of 0 to a maximum value of 191. For the wheel, the coordinate will wrap around from 191 back to 0 and vice versa when scrolling through position A.

## 7.4 Non-Wrap Around Sliders in Wheel Mode

Both 2 channel and 3 channel non-wrap around sliders can also be implemented in wheel mode. This will allow a coordinate value to be read from the **IQS263B** instead of having to calculate it with the MCU. However, this will reduce the coordinate range as shown below.

For a 2 channel slider the coordinate will range from 0 to 64 as shown in figure 7.4 and table 7.4 below.

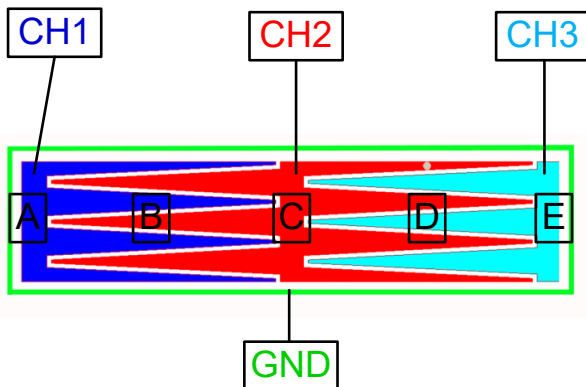


Positions	Coordinates
A	0/191
A to B	1 to 31
B	32
B to C	33 to 63
C	64

**Table 7.4** Coordinate mapping for a 2 channel slider in Wheel mode.

**Figure 7.4** Finger positions for coordinate mapping shown on a 2 channel slider in Wheel mode.

For a 3 channel slider the coordinate will range from 0 to 127 as shown in figure 7.5 and table 7.5 below.



Positions	Coordinates
A	0/191
A to B	1 to 31
B	32
B to C	33 to 63
C	64
C to D	65 to 95
D	96
D to E	97 to 126
E	127

**Table 7.5** Coordinate mapping for a 3 channel slider in Wheel mode.

**Figure 7.5** Finger positions for a 3 channel slider in Wheel mode.

It should be noted that non-wrap around 2 channel and 3 channel sliders in wheel mode will sometimes output a value of 191 instead of 0 when touched at the zero end of the slider. Provision must be made in the MCU code for this.



## 8 ProxSense® Module

The **IQS263B** contains a ProxSense® module that uses patented technology to provide detection of proximity and touch conditions on numerous sensing lines.

The ProxSense® module is a combination of hardware and software, based on the principles of charge transfer measurements.

### 8.1 Charge Transfer Concept

On ProxSense® devices like the **IQS263**, capacitance measurements are taken with a charge transfer process that is periodically initiated.

For projected capacitive sensing, the device measures the capacitance between 2 electrodes referred to as the transmitter (CTX) and receiver (CRX).

The measuring process is referred to as a charge transfer cycle and consists of the following:

- Discharging of an internal sampling capacitor ( $C_s$ ) and the electrode capacitors (mutual: CTX & CRX) on a channel.
- charging of CTX's connected to the channel
- and then a series of charge transfers from the CRX's to the internal sampling capacitors ( $C_s$ ), until the trip voltage is reached.

The number of charge transfers required to reach the trip voltage on a channel is referred to as the Current Samples (**CS**) or Count value (Counts).

The device continuously repeats charge transfers on the sense electrodes connected to the CRX pins. For each channel a Long Term Average (**LTA**) is calculated (12 bit unsigned integer values).

The count (CS) values (12 bit unsigned integer values) are processed and compared to the LTA to detect Touch and Proximity events.

**Please note: Attaching scope probes to the CTX/CRX pins will influence the capacitance of the sense electrodes and therefore the related CS values of those channels. This will have an instant effect on the CS measurements.**

### 8.2 Rate of Charge Cycles

The **IQS263B** samples all its active channels (up to 3 + channel 0 for proximity) in 4 timeslots. The charge sequence (as measured on the receive electrodes) is shown in Figure 8.1, where CH0, the Proximity channel, charges first, followed by all other active channels. There is only a communication window after all active channels have been charged.

The charging of CH0 comprises the simultaneous charging of the three receive electrodes (CRX0, CRX1 and CRX2) in conjunction with the transmit electrode, thus realising a distributed load mutual capacitive sense electrode.

In self-capacitive mode, CH0 is also a distributed channel charging all 3 CX channels together.

#### 8.2.1 Boost Power rate

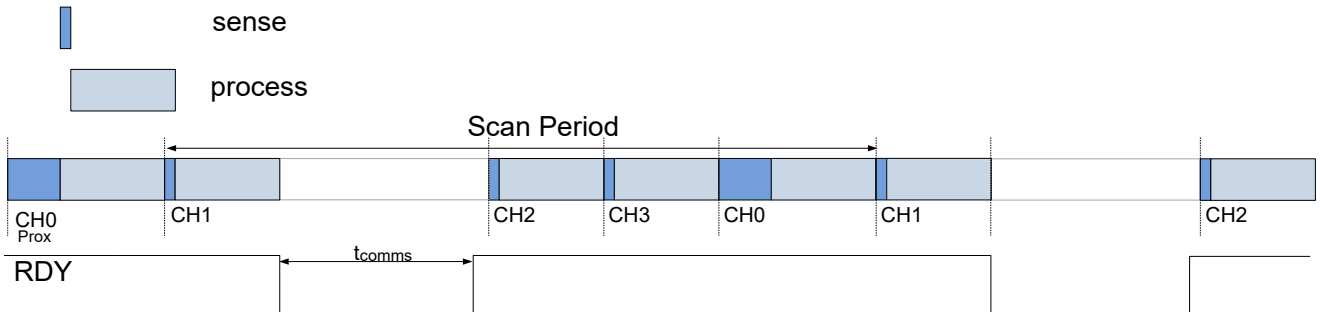
With the **IQS263B** zoomed to Boost Power (BP) mode, the active channels are charged at a fixed sampling period ( $t_{SAMPLE}$ ) per channel (if Turbo Mode is not enabled). This is done to ensure regular samples for processing of results, and fix timings for the halt times.

It is calculated as each channel having a time  $t_{SAMPLE} = \text{charge/conversion time } (t_{SENSE}) + \text{computation time } (t_{PROCESS})$  of approximately  $t_{SAMPLE} = 1.6\text{ms}$ . Thus the time between consecutive samples on a specific channel (Scan Period) will depend on the number of enabled channels and the



length of communication between the **IQS263B** and the host MCU. Communication will always happen after processing of channel 0. Due to processing and charging happening in parallel, the first active channel (default channel 1) will charge while channel 0 is processed.

Therefore, communication windows will always be after the first active channel has completed conversions. The **IQS263B** does check for MCU requesting a communication window after ever channel completed charging.



**Figure 8.1 IQS263B Charge Sequence timing diagram in Boost Power mode.**

**Table 8.1 Typical Timings**

Typical timings of IQS263		
$t_{sense}$	840	$\mu s$
$t_{process}$	3.9	ms
$t_{comms}$	2	ms
Scan Period <sup>1</sup>	22	ms

Typical timings of the charge sequence shown above are listed in Table 8.1. These timings are only as reference, as they will differ with each application, depending on the setup of the **IQS263**. For example, the sense (or charge time) is affected by the target counts and charge transfer frequency, while process time is dependent on the turbo mode activation, ATI checking for counts within the allowed band, filter settings and slider calculations. Communication time is affected by the MCU clock speed and the amount of data read (as well as the sequence thereof). Communication time and the number of active channels will influence the Scan Period.

<sup>1</sup> All channels active and status byte read during communication window. Self capacitive mode, all other settings default.



### 8.2.2 Low Power rate

A wide range of low current consumption charging modes is available on the **IQS263**.

In any Low Power (LP) mode, there will be an applicable low power time ( $t_{LP}$ ).

With the detection of an undebounced proximity event the IC will zoom to BP mode, allowing a very fast reaction time for further possible touch events.

During any LP mode, only channel 0 is charged every  $t_{LP}$ . The LP charge timing is illustrated in **Figure 6.1**.

If a low power rate is selected and charging is not in the zoomed state (BP mode), the low power active bit (Register 0x01) will be set.

Please refer to **Section 6.12**.

### 8.3 Touch report Rate

During Boost Power (BP) mode, the touch report rate of the **IQS263B** device depends on the charge transfer frequency, the number of channels enabled and the length of communications performed by the host MCU or master device.

Several factors may influence the touch report rate:

- **Enabled channels:** Disabling channels that are not used will not only increase the touch report rate, but will also reduce the device's current consumption.
- **Turbo Mode:** See Section 6.5.6
- **Target Values:** Lower target values requires shorter charge transfer times ( $t_{SENSE}$ ), thus reducing the SCAN PERIOD and increasing the touch report rate.
- **Charge Transfer Speed:** Increasing the charge transfer frequency will

reduce the conversion time ( $t_{SENSE}$ ) and increase the touch report rate.

- **ACF:** Disabling the AC filter and wheel/slider position calculations will reduce the processing time ( $t_{PROCESS}$ ) and yield a faster report rate.

### 8.4 Long Term Average

The Long-term Average (LTA) filter can be seen as the baseline or reference value. The LTA is calculated to continuously adapt to any environmental drift. The LTA filter is calculated from the CS value for each channel. The LTA filter allows the device to adapt to environmental (slow moving) changes/drift. Actuation (Touch or Prox) decisions are made by comparing the CS value with the LTA reference value.

### 8.5 Determine Touch or Prox

An event is determined by comparing the CS value with the LTA. Since the CS reacts differently when comparing the self- with the mutual capacitance technology, the user should consider only the conditions for the technology used.

An event is recorded if:

- Self:  $CS < LTA - \text{Threshold}$
- Projected:  $CS > LTA + \text{Threshold}$

**Threshold** can be either a Proximity or Touch threshold, depending on the current channel being processed.

Note that a proximity condition will be forced enabled if there is a touch condition on any channel.

Please refer to **Section 6.7** and **6.8** for proximity and touch threshold selections.





## 8.6 ATI

The **Automatic Tuning Implementation (ATI)** is a sophisticated technology implemented on the new ProxSense® series devices. It allows for optimal performance of the devices for a wide range of sense electrode capacitances, without modification or addition of external components.

The ATI allows the tuning of two parameters, an ATI Multiplier and an ATI Compensation, to adjust the Count values for an attached sense electrode.

ATI allows the designer to optimize a specific design by adjusting the sensitivity and stability of each channel through the adjustment of the ATI parameters.

The **IQS263B** has a full ATI function. The full-ATI function is default enabled, but can be disabled by setting the `ATI_OFF` bit, or changed to partial or alternative ATI by setting the `ATI_Partial` and `ATI_ALT`.

The `ATI_Busy` bit will be set while an ATI event is busy.

For more information regarding the ATI algorithm, please contact Azoteq at: [ProxSenseSupport@azoteq.com](mailto:ProxSenseSupport@azoteq.com)

### 8.6.1 ATI Sensitivity

On the **IQS263B** device, the user can specify the **BASE** value (**Section 6.13**) and the **TARGET** value (**Section 6.14**) for the proximity channel (CH0) and touch channels (CH1-CH3).

A rough estimation of sensitivity can be calculated as:

$$\text{Sensitivity} \propto \frac{\text{TARGET}}{\text{BASE}}$$

As can be seen from this equation, the sensitivity can be increased by either increasing the Target value or decreasing the Base value. It should, however, be

noted that a higher sensitivity will yield a higher noise susceptibility.

### 8.6.2 ATI Target

The target value is reached by adjusting the `COMPENSATION` bits for each channel (ATI target limited to 2048 counts).

The target value is written into the respective channel's `TARGET` registers. The value written into these registers multiplied by 8 will yield the new target value. (Please refer to **Section 6.14**)

### 8.6.3 ATI Base (Multiplier)

The following parameters will influence the base value:

- `Cs_SIZE`<sup>1</sup>: Size of sampling capacitor.
- `PROJ_BIAS` bits: Adjusts the biasing of some analogue parameters in the mutual capacitive operated IC. (Only applicable in mutual capacitance mode.)
- Charge Transfer Frequency
- `MULTIPLIER` bits.

The base value used for the ATI function can be implemented in 2 ways:

1. `ATI_PARTIAL` = 0. ATI automatically adjusts `MULTIPLIER` bits to reach a selected base value<sup>2</sup>. Please refer to **Section 6.13** for available base values.
2. `ATI_PARTIAL` = 1. The designer can specify the multiplier settings. These settings will give a custom base value from where the compensation bits will be automatically implemented to reach the required target value. The base value is

<sup>1</sup> Changing `CS_SIZE` if `ATI_OFF` = 0 will change `CS`

<sup>2</sup> ATI function will use user selected `CS_SIZE` and `PROJ_BIAS` (if applicable) and will only adjust the `MULTIPLIER` bits to reach the base values.



determined by two sets of multiplier bits. Sensitivity Multipliers which will also scale the compensation to normalise the sensitivity and Compensation Multipliers to adjust the gain.

#### **8.6.4 Re-ATI**

An automatic re-ATI event will occur if the counts are outside its re-ATI limits. The re-ATI limit or ATI boundary is calculated as the target value divided by 8. For example:

- Target = 512, Re-ATI will occur if CS is outside  $512 \pm 64$ .

A re-ATI event can also be issued by the host MCU by setting the REDO\_ATI bit. The REDO\_ATI bit will clear automatically after the ATI event was started.

Note: Re-ATI will automatically clear all proximity, touch and halt status bits.

#### **8.6.5 ATI ERROR**

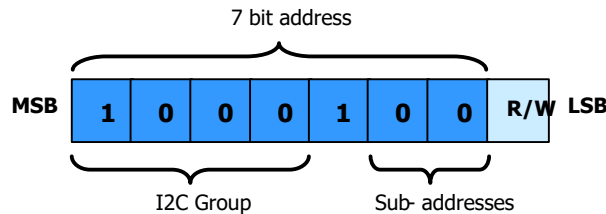
The ATI error bit (read only) indicates to the user that the ATI targets were not reached. Adjustments of the base values or ATI BANDs are required.

## 9 Communication

The IQS263B device interfaces to a master controller via a 3-wire (SDA, SCL and RDY) serial interface bus that is I<sup>2</sup>C™ compatible, with a maximum communication speed of 400kbit/s.

### 9.1 Control Byte

The Control byte indicates the 7-bit device address (44H default) and the Read/Write indicator bit. The structure of the control byte is shown in Figure 9.1.

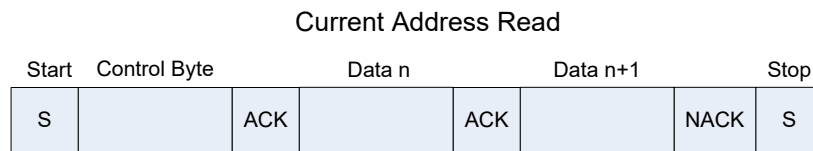


**Figure 9.1 IQS263B Control Byte.**

The I<sup>2</sup>C device has a 7 bit Slave Address (default 0x44H) in the control byte as shown in Figure 9.1. To confirm the address, the software compares the received address with the device address. Sub-address values can be set by OTP programming options.

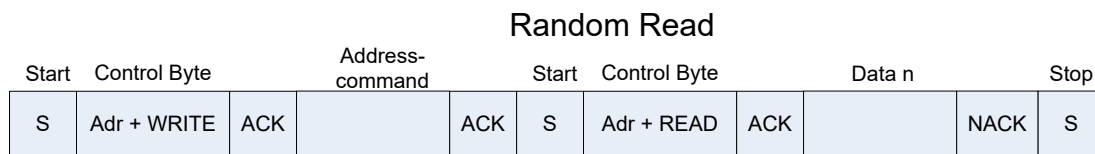
### 9.2 I<sup>2</sup>C Read

To read from the device a *current address read* can be performed. This assumes that the address-command is already setup as desired.



**Figure 9.2 Current Address Read.**

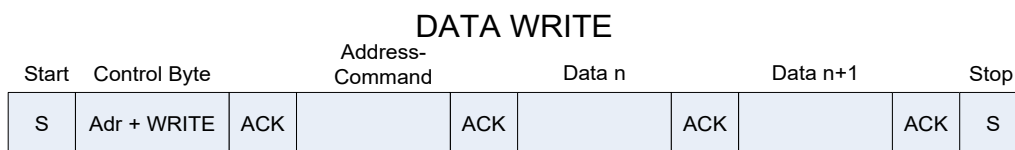
If the address-command must first be specified, then a *random read* must be performed. In this case a WRITE is initially performed to setup the address-command, and then a repeated start is used to initiate the READ section.



**Figure 9.3 Random Read.**

### 9.3 I<sup>2</sup>C Write

To write settings to the device a *Data Write* is performed. Here the Address-Command is always required, followed by the relevant data bytes to write to the device.



**Figure 9.4 I<sup>2</sup>C Write.**



## 9.4 End of Communication Session / Window

Similar to other Azoteq I<sup>2</sup>C devices, to end the I<sup>2</sup>C communication session, a STOP command is given. When sending numerous read and write commands in one communication cycle, a repeated start command must be used to stack them together (since a STOP will jump out of the communication window, which is not desired).

The STOP will then end the communication, and the **IQS263B** will return to process a new set of data. Once this is obtained, the communication window will again become available (RDY set LOW).

## 9.5 I<sup>2</sup>C Sub-address

The **IQS263B** has four available sub addresses, 44H (default) to 47H, which allows up to four devices on a single I<sup>2</sup>C bus.

### 9.5.1 Internal sub-address selection

Selecting the sub-address via OTP bits allows the user 4 different options:

**Table 9.1 I<sup>2</sup>C sub-address selection**

FG25	FG26	Device Address
0	0	0x44
0	1	0x45
1	0	0x46
1	1	0x47

## 9.6 RDY Hand-Shake Routine

The master or host MCU has the capability to request a communication window at any time, by pulling the RDY line low. The communication window will open directly following the current conversion cycle. For more details please refer to the communication interface guide.

## 9.7 I<sup>2</sup>C Specific Commands

### 9.7.1 Show Reset

After start-up, and after every reset event, the “Show Reset” flag will be set in the [System Flags register \(0x01H; byte 0\)](#).

The “Show Reset” bit can be read to determine whether a reset has occurred on the device (it is recommended to be continuously monitored). This bit will be set ‘1’ after a reset.

The SHOW\_RESET bit will be cleared (set to ‘0’) by writing a ‘0’ into the “Show Reset”

bit. A reset will typically take place if a timeout during communication occurs.

### 9.7.2 I<sup>2</sup>C Timeout

If no communication is initiated from the master/host MCU within the first  $t_{COMMS}$  ( $t_{COMMS} = 5.12ms$  default) of the RDY line indicating that data is available (i.e. RDY = low), the device will resume with the next cycle of charge transfers and the data from the previous conversions will be lost. The timeout time is adjustable in steps of 1.28ms in the [Thresholds register \(0x0A; byte 7\)](#). There is also a timeout ( $t_{I2C}$ ) that cannot be disabled, for when communication has started but not been completed, for example when the bus is being held by another device.  $t_{I2C} = 150ms$ .

## 9.8 I<sup>2</sup>C I/O Characteristics

The **IQS263B** requires the input voltages given in **Table 9.2**, for detecting high (“1”) and low (“0”) input conditions on the I<sup>2</sup>C communication lines (SDA, SCL and RDY).

**Table 9.2 IQS263B I<sup>2</sup>C Input voltage**

	Input Voltage (V)
V <sub>inLOW</sub>	0.3*VDDHI
V <sub>inHIGH</sub>	0.7*VDDHI

Table 9.3 provides the output voltage levels of the **IQS263B** device during I<sup>2</sup>C communication.

**Table 9.3 IQS263B I<sup>2</sup>C Output voltage**

	Output Voltage (V)
V <sub>outLOW</sub>	GND +0.2 (max.)



Vout <sub>HIGH</sub>	VDDHI – 0.2 (min.)
----------------------	--------------------

## 10 Communication Command/Address Structure

### 10.1 Registers & Memory map

Table 10.1 IQS263B Registers

Address	Description	Access	Section
0x00H	<b>Device Information</b>	R	<a href="#">10.2.1</a>
0x01H	<b>System Flags</b>	R/W	<a href="#">10.2.2</a>
0x02H	<b>Coordinates</b>	R	<a href="#">10.2.3</a>
0x03H	<b>Touch Bytes</b>	R	<a href="#">10.2.4</a>
0x04H	<b>Counts</b>	R	<a href="#">10.2.5</a>
0x05H	<b>LTA</b>	R	<a href="#">10.2.6</a>
0x06H	<b>Deltas</b>	R	<a href="#">10.2.7</a>
0x07H	<b>Multipliers</b>	R/W	<a href="#">10.2.8</a>
0x08H	<b>Compensation</b>	R/W	<a href="#">10.2.9</a>
0x09H	<b>ProxSettings</b>	R/W	<a href="#">10.2.10</a>
0x0AH	<b>Thresholds</b>	R/W	<a href="#">10.2.11</a>
0x0BH	<b>Timings &amp; Targets</b>	R/W	<a href="#">10.2.12</a>
0x0CH	<b>Gesture Timers</b>	R/W	<a href="#">10.2.13</a>
0x0DH	<b>Active Channels</b>	R/W	<a href="#">10.2.14</a>



## 10.2 Registers Descriptions

### 10.2.1 Device Information 0x00H

Information regarding the device type and version is recorded here. Any other information specific to the device version can be stored here. Each Azoteq ROM has a unique Product- and Version number.

		Product Number (PROD_NUM)							
Access	Bit	7	6	5	4	3	2	1	0
R	Value	0x3C							

		Version Number (VERSION_NUM)							
Access	Bit	7	6	5	4	3	2	1	0
R	Value	0x01							

### 10.2.2 System Flags 0x01H

		System Flags (SYSFLAGS0)							
Access	Bit	7	6	5	4	3	2	1	0
R/W	Name	<a href="#">Show Reset</a>	Movement	<a href="#">ATI Error</a>	<a href="#">Proj Mode</a>	Filter Halt	ATI Busy	<a href="#">Ind Halt</a>	LP Active

- Bit 7:** 0 = Reset has NOT occurred.  
1 = Reset has occurred. Write to 0 to clear.
- Bit 6:** 0 = No movement detected.  
1 = Movement detected.
- Bit 5:** 0 = ATI Error has NOT occurred.  
1 = ATI Error has occurred.
- Bit 4:** 0 = Self capacitive mode selected.  
1 = Projected capacitive mode selected.
- Bit 3:** Will show only if “Ind Halt” bit is set to 0.  
0 = A global filter halt is not active.  
1 = A global filter halt is active.
- Bit 2:** 0 = Device is not busy with ATI.  
1 = Device is busy with ATI.
- Bit 1:** 0 = Global Filter Halt enabled.  
1 = Global Filter Halt disabled.
- Bit 0:** 0 = Low Power mode is not active.  
1 = Low Power mode is active.



		Events							
Access	Bit	7	6	5	4	3	2	1	0
R	Name	Flick Right	Flick Left	Tap	Movement	ATI Event	Slide Event	Touch Event	Prox Event

### 10.2.3 Wheel Coordinates 0x02H

		Wheel 1 Low							
Access	Bit	7	6	5	4	3	2	1	0
R	Name	Wheel 1 Coordinate Low byte first							

		Relative Coordinate Low							
Access	Bit	7	6	5	4	3	2	1	0
R	Name	Relative Coordinate Low byte first							

		Relative Coordinate High							
Access	Bit	7	6	5	4	3	2	1	0
R	Name	Relative coordinate High byte							

### 10.2.4 Touch Bytes 0x03H

		Touch Byte 0							
Access	Bit	7	6	5	4	3	2	1	0
R	Name					CH3	CH2	CH1	CH0 <sup>1</sup>

		Halt Byte 1							
Access	Bit	7	6	5	4	3	2	1	0
R	Name					CH3	CH2	CH1	CH0 <sup>2</sup>

Bit 0 of the first byte (CH0) will indicate proximity events; the rest of the bits indicate touches as shown. The second byte shows the halt status bits.

<sup>1</sup> CH0 indicates Proximity, not Touch.

<sup>2</sup> CH0 indicates Proximity, not Touch.



### 10.2.5 Counts 0x04H

This register has 10 bytes to store the count values of the low power channel and then CH0 up to CH3 the low byte will always read out first, followed by the high byte, before the moving to the next channel.

		Low Power Channel Low							
Access	Bit	7	6	5	4	3	2	1	0
R	Name	Low Power Channel CS (Counts) Low byte first							
Byte 0									

		CH 3 Counts High byte							
Access	Bit	7	6	5	4	3	2	1	0
R	Name	Channel 3 Count value (High byte last)							
Byte 9									

### 10.2.6 LTA 0x05H

This register has 10 bytes to store the LTA values of the low power channel and then CH0 up to CH3 the low byte will always read out first, followed by the high byte, before the moving to the next channel.

		Low Power Channel LTA Low byte							
Access	Bit	7	6	5	4	3	2	1	0
R	Name	Low Power Channel LTA value (Low byte first)							
Byte 0									

		CH 3 LTA High byte							
Access	Bit	7	6	5	4	3	2	1	0
R	Name	Channel 3, LTA value (High byte last)							
Byte 9									





### 10.2.7 Deltas 0x06H

This register has 8 bytes to store the Delta (the difference between Count and LTA) values of CH0 up to CH3. The low byte will always read out first, followed by the high byte, before the moving to the next channel. Deltas are not available when using the wheel setting.

		Delta Counts for CH0 Low							
Access	Bit	7	6	5	4	3	2	1	0
R	Name	Delta for CH0 – Low Byte first							
Byte 0									

		Delta Counts for CH3 High							
Access	Bit	7	6	5	4	3	2	1	0
R	Name	Delta for CH3 – High Byte last							
Byte 7									

### 10.2.8 Multipliers 0x07H

		CH0 Multipliers							
Access	Bit	7	6	5	4	3	2	1	0
R/W	Name	Sensitivity Multipliers			Comp Multipliers				
Byte 0									

		CH1 Multipliers							
Access	Bit	7	6	5	4	3	2	1	0
R/W	Name	Sensitivity Multipliers			Comp Multipliers				
Byte 1									

		CH2 Multipliers							
Access	Bit	7	6	5	4	3	2	1	0
R/W	Name	Sensitivity Multipliers			Comp Multipliers				
Byte 2									



		CH3 Multipliers							
Access	Bit	7	6	5	4	3	2	1	0
R/W	Name				Sensitivity Multipliers		Comp Multipliers		
Byte 3									

		CH1/CH0 Base Values							
Access	Bit	7	6	5	4	3	2	1	0
R/W	Name	Channel 1				Channel 0			
Byte 4	Default	0x44							

		CH3/CH2 Base Values							
Access	Bit	7	6	5	4	3	2	1	0
R/W	Name	Channel 3				Channel 2			
Byte 5	Default	0x44							

Base Value Options:

0000	- 74	1000	- 202
0001	- 90	1001	- 218
0010	- 106	1010	- 234
0011	- 122	1011	- 250
0100	- 138 (default)	1100	- 266
0101	- 154	1101	- 282
0110	- 170	1110	- 298
0111	- 186	1111	- 314



### 10.2.9 Compensation 0x08H

		CH0 Compensation value							
Access	Bit	7	6	5	4	3	2	1	0
R/W	Name	Channel 0 Compensation							
Byte 0									

		CH 3 Compensation Value							
Access	Bit	7	6	5	4	3	2	1	0
R/W	Name	Last active channel Compensation							
Byte 3									

### 10.2.10 ProxSettings 0x09H

		ProxSettings0							
Access	Bit	7	6	5	4	3	2	1	0
R/W	Name	<a href="#">ATI</a> <a href="#">OFF</a>	<a href="#">ATI</a> <a href="#">Partial</a>	<a href="#">ATI</a> <a href="#">Band</a>	<a href="#">Redo</a> <a href="#">ATI</a>	<a href="#">Reseed</a>	<a href="#">Stream</a> <a href="#">ATI</a>	<a href="#">4MHz</a>	<a href="#">Force</a> <a href="#">Halt</a>
Byte 0	Default	0x00H							

**Bit 7:** 0 = ATI Enable  
1 = ATI Disabled

**Bit 6:** 0 = Full ATI  
1 = Partial ATI

**Bit 5:** 0 = 1/8 \* LTA  
1 = 1/4 \*LTA

**Bit 4:** 0 = No Action  
1 = Redo ATI

**Bit 3:** 0 = No Action  
1 = Send Reseed

**Bit 2:** 0 = No communication widows during ATI routine  
1 = Communication windows after each charge cycle regardless of ATI busy.

**Bit 1:** 0 = 2MHz Oscillator  
1 = 4MHz Oscillator

**Bit 0:** 0 = No Action  
1 = Forcing all LTAs to stop calculating



		ProxSettings1							
Access	Bit	7	6	5	4	3	2	1	0
R/W	Name	<a href="#">WDT OFF</a>	<a href="#">Event Mode</a>	<a href="#">LTA Beta</a>		<a href="#">Slider</a>		<a href="#">CF</a>	
Byte 1	Default	0x11H							

- Bit 7:** 0 = WDT Enable  
1 = WDT Disabled
- Bit 6:** 0 = Streaming Mode  
1 = Event Mode
- Bit 5:4:** 00 = 2<sup>9</sup>  
01 = 2<sup>8</sup> (default)  
10 = 2<sup>7</sup>  
11 = 2<sup>6</sup> (fastest following)
- Bit 3:2:** 00 = Slider Disabled  
01 = 2CH Slider  
10 = Wheel (Also used for 3CH wrap around slider)  
11 = 3CH Slider
- Bit 1:0:** 00 = Counts Filtering OFF  
01 = Beta - 01  
10 = Beta - 02  
11 = Beta - 03 (largest filter for noise suppression, slowest response)

		ProxSettings2							
Access	Bit	7	6	5	4	3	2	1	0
R/W	Name	<a href="#">Sleep Halt</a>	<a href="#">Force Sleep</a>	<a href="#">Wake Release</a>	<a href="#">Wheel Filter</a>	<a href="#">Movement</a>		<a href="#">OUT</a>	
Byte 2	Default	0x00H							

- Bit 7:** 0 = Reseed upon Halt timer expiration  
1 = Return to LP upon Halt timer expiration
- Bit 6:** 0 = No Action  
1 = Send Force Sleep
- Bit 5:** 0 = Wake from LP only in the normal direction (Counts below LTA for Self)  
1 = Wake from LP for counts in both direction
- Bit 4:** 0 = Coordinate Filter Enabled  
1 = Coordinate Filter Disabled
- Bit 3:2:** 00 = Movement Disabled  
01 = Movement on CH0  
10 = Movement on CH3



**Bit 1:0:** 00 = Prox  
01 = Sync (ZC input)  
10 = Touch on CH1  
11 = Movement output

		ProxSettings3							
Access	Bit	7	6	5	4	3	2	1	0
R/W	Name	<a href="#">Touch Debounc</a> <a href="#">e</a>	<a href="#">Off Mode</a>	<a href="#">Proj Bias</a>	<a href="#">Float Cx</a>	<a href="#">Halt Charge</a>	<a href="#">Turbo Mode</a>	<a href="#">Filtered Touches</a>	<a href="#">Xfer</a>
Byte 3	Default	0x00H							

**Bit 7:** 0 = 2 consecutive samples  
1 = 4 Sample

**Bit 6:** 0 = off mode disabled  
1 = off mode enabled

**Bit 5:** 0 = 10uA  
1 = 20uA

**Bit 4:** 0 = Grounded  
1 = Floating

**Bit 3:** 0 = Normal Charging  
1 = Halt All Channels' Charging

**Bit 2:** 0 = Turbo Mode Enabled  
1 = Turbo Mode Disabled

**Bit 1:** 0 = Touch detection on unfiltered counts  
1 = Touch detection on filtered counts

**Bit 0:** 0 = Fast Charging  
1 = Slower Charging

		Event Mask							
Access	Bit	7	6	5	4	3	2	1	0
R/W	Name	Flick Left	Flick Right	Tap	Move ment	ATI	Slide	Touch	Prox
Byte 4	Default	0xFFH							



10.2.11 Thresholds 0x0A

		Proximity Threshold							
Access	Bit	7	6	5	4	3	2	1	0
R/W	Name	Value							
Byte 0	Default	4D							

		Touch Threshold CH1							
Access	Bit	7	6	5	4	3	2	1	0
R/W	Name	1-255							
Byte 1	Default	16D							

		Touch Threshold CH3							
Access	Bit	7	6	5	4	3	2	1	0
R/W	Name	1-255							
Byte 3	Default	16D							

		Movement Threshold							
Access	Bit	7	6	5	4	3	2	1	0
R/W	Name	1-255							
Byte 4	Default	3D							

		Halt timeout Reseed Block								
Access	Bit	7	6	5	4	3	2	1	0	
R/W	Name						<a href="#">CH3</a>	<a href="#">CH2</a>	<a href="#">CH1</a>	
Byte 5	Default	0								



		Halt Time in Number of Samples							
Access	Bit	7	6	5	4	3	2	1	0
R/W	Name	Value times 50 (FF = Always; 00 = Never)							
Byte 6	Default	20D							

		I2C Timeout							
Access	Bit	7	6	5	4	3	2	1	0
R/W	Name	Value times 1.28ms							
Byte 7	Default	4D							

### 10.2.12 Timings 0x0BH

		Low Power Time							
Access	Bit	7	6	5	4	3	2	1	0
R/W	Name	Steps of 16ms (Value times 16ms)							
Byte 0	Default	0x00H							

		ATI Target for Touch Channels							
Access	Bit	7	6	5	4	3	2	1	0
R/W	Name	Steps of 8 (Value times 8)							
Byte 1	Default	48D							

		ATI Target for Proximity							
Access	Bit	7	6	5	4	3	2	1	0
R/W	Name	Steps of 8 (Value times 8)							
Byte 2	Default	64D							



### 10.2.13 Gesture Timers 0x0CH

		Tap Timer							
Access	Bit	7	6	5	4	3	2	1	0
R/W	Name	Tap Timer Limit							
Byte 0	Default	5D							

		Flick Timer							
Access	Bit	7	6	5	4	3	2	1	0
R/W	Name	Flick Timer Limit							
Byte 1	Default	20D							

		Flick Threshold							
Access	Bit	7	6	5	4	3	2	1	0
R/W	Name	Flick Threshold Value							
Byte 2	Default	50D							

### 10.2.14 Active Channels 0x0DH

		Active Chan 0							
Access	Bit	7	6	5	4	3	2	1	0
R/W	Name					CH3	CH2	CH1	CH0
Byte 0	Default	0x0FH							





## 11 Specifications

### 11.1 Absolute Maximum Specifications

The following absolute maximum parameters are specified for the device:

*Exceeding these maximum specifications may cause damage to the device.*

- Operating temperature -20°C to 85°C
- Supply Voltage (VDDHI – GND) 3.6V
- Maximum pin voltage VDDHI + 0.5V (may not exceed VDDHI max)
- Maximum continuous current (for specific Pins) 10mA
- Minimum pin voltage GND - 0.5V
- Minimum power-on slope 100V/s
- ESD protection ±8kV (Human body model)

**Table 11.1 IQS263B Self Capacitive General Operating Conditions<sup>1</sup>**

DESCRIPTION	Conditions	PARAMETER	MIN	TYP	MAX	UNIT
Supply voltage		V <sub>DDHI</sub>	1.8	3.3V	3.6	V
Internal regulator output	1.8 ≤ V <sub>DDHI</sub> ≤ 3.6	V <sub>REG</sub>	1.62	1.7	1.79	V
Streaming mode*	3.3V	80Hz		180		µA
Event Mode		80Hz		90	150	µA
Low Power Setting 8**		128ms		4	6.5	µA
Low Power Setting 16**		256ms		3	4	µA

**Table 11.2 IQS263B Projected Capacitive General Operating Conditions**

DESCRIPTION	Conditions	PARAMETER	MIN	TYP	MAX	UNIT
Supply voltage		V <sub>DDHI</sub>	1.8	3.3V	3.6	V
Internal regulator output	1.8 ≤ V <sub>DDHI</sub> ≤ 3.6	V <sub>REG</sub>	1.62	1.7	1.79	V
Streaming mode	3.3V	80Hz	-	305		µA
Event Mode		80Hz	-	230		µA
Low Power Setting 8**		128ms	-	5	11	µA
Low Power Setting 16**		256ms	-	4	6	µA

\* Current consumption for streaming mode will differ with number of bytes read, speed and pull up resistor values

\*\* LP interval period = Low power value x 16ms

<sup>1</sup>Current values shown in this datasheet, does not include dissipation through I<sup>2</sup>C pull up resistors unless streaming mode is indicated.



**Table 11.3 Start-up and shut-down slope Characteristics**

DESCRIPTION	Conditions	PARAMETER	MIN	MAX	UNIT
Power On Reset	$V_{DDHI}$ Slope $\geq 100V/s$ @25°C	POR		1.6	V
Brown Out Detect	$V_{DDHI}$ Slope $\geq 100V/s$ @25°C	BOD	1.05		V

**Table 11.4 Electrode Specifications – Self Capacitance**

DESCRIPTION	Conditions	PARAMETER	MAX	UNIT
Parasitic Capacitance CX to GND		$C_P$	120	pF
Series Resistor	$C_P = 120pF$	$R_S$	10	kΩ

**Table 11.5 Electrode Specifications – Mutual Capacitance**

DESCRIPTION	Conditions	PARAMETER	MIN	MAX	UNIT
Parasitic Capacitance Tx to GND		$C_T$		100	pF
Parasitic Capacitance Rx to GND		$C_R$		100	pF
Mutual Capacitance		$C_M$	0.1	10	pF
Series Resistor		$R_{TX}$		10	kΩ
Series Resistor	$C_M = 1pF$	$R_{RX}$		1	kΩ



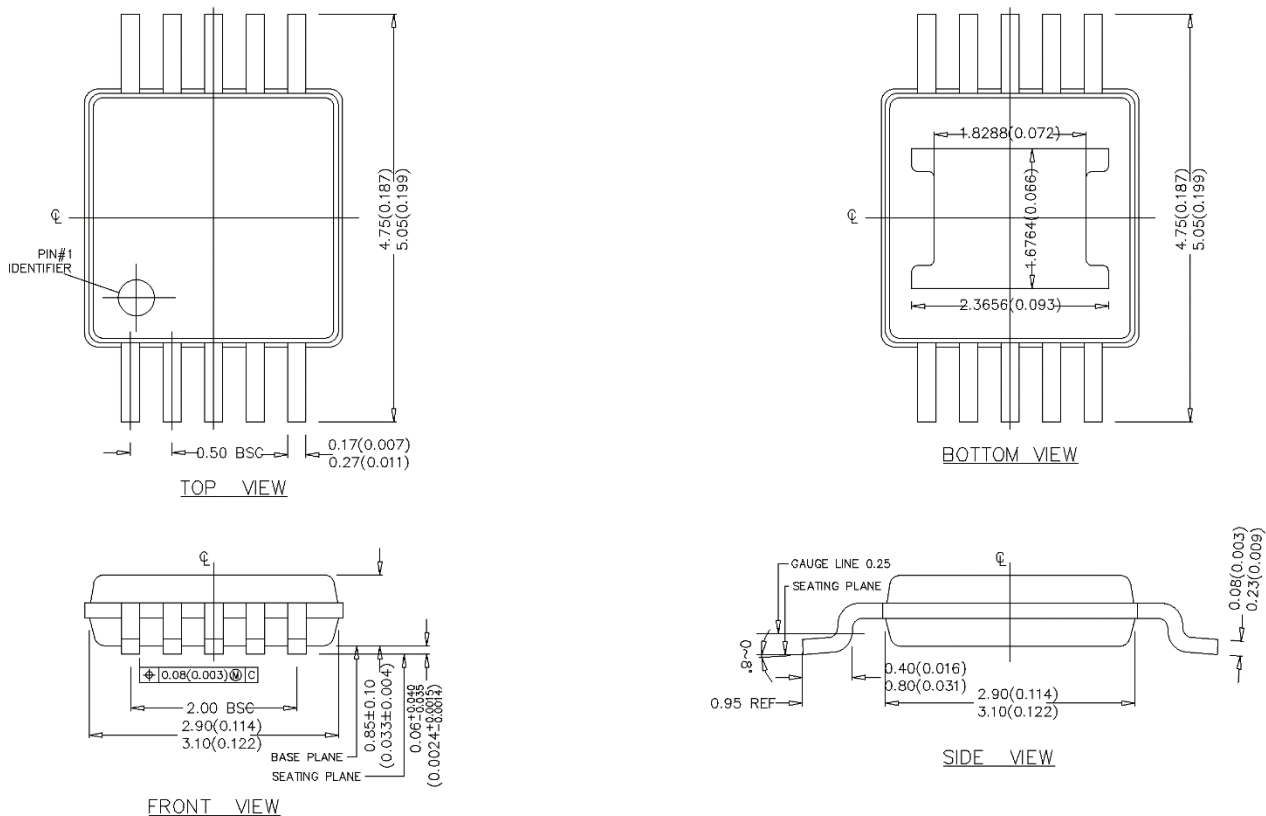
**Table 11.6 ATI Times**

<b>Turbo Mode Off</b>								
Oscillator	2MHZ				4MHZ			
Target value	Low		High		Low		High	
Channels active	1	3	1	3	1	3	1	3
Typical time [ms]	625	625	630	630	310	300	313	305
Worst case	850 (34 cycles @25ms per cycle)							
<b>Turbo Mode On</b>								
Oscillator	2MHZ				4MHZ			
Target value	Low		High		Low		High	
Channels active	1	3	1	3	1	3	1	3
Typical time [ms]	200	350	240	420	105	175	120	205
Worst case	500 - 600 (34 cycles estimate)							
<b>ATI Error / Failure</b>								
Worst case Including re-tries		4.7 seconds (189 cycles @25ms per cycle)			Something is wrong with settings or electrode(s)			



## 12 Packaging Information

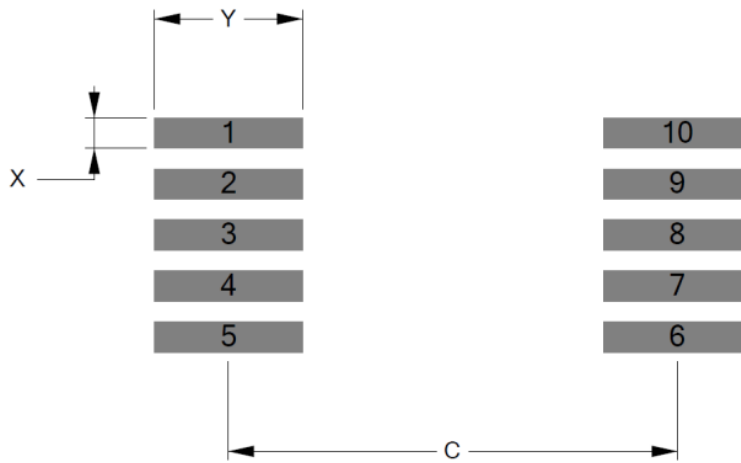
### 12.1 MSOP-10



#### NOTES:

- 1) THIS DRAWING IS FOR CUSTOMER PURPOSE.
- 2) LEADFRAME MATERIAL : C7025 (THICKNESS: 0.15MM).
- 3) BOTH PACKAGE LENGTH & WIDTH DO NOT INCLUDE MOLD FLASH.
- 4) FORMED LEAD SHALL BE PLANAR WITH RESPECT TO ONE ANOTHER WITHIN 0.10MM.
- 5) UNREMOVED FLASH BETWEEN LEADS & PACKAGE END FLASH SHALL NOT EXCEED 0.15MM FROM BOTTOM BODY.
- 6) CONTROLLING DIMENSION : MM(INCH).

Figure 12.1 MSOP-10 Package Dimensions.



**Figure 12.2 MSOP-10 Footprint.**

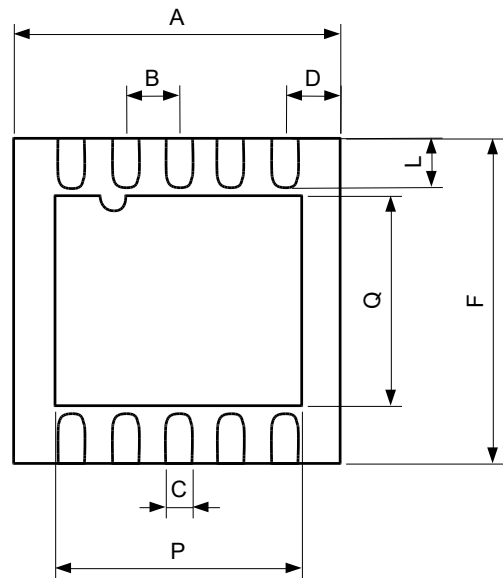
**Table 12.1 MSOP-10 Footprint Dimensions from Figure 12.2.**

<b>Dimension</b>	<b>[mm]</b>
Pitch	0.50
C	4.40
Y	1.45
X	0.30

## 12.2 DFN10

**Table 12.2 DFN-10 Package dimensions (bottom)**

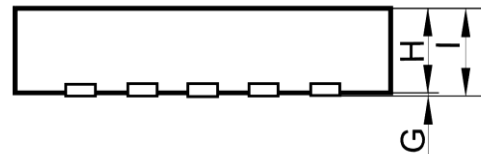
Dimension	[mm]
A	3 ±0.1
B	0.5
C	0.25
D	n/a
F	3 ±0.1
L	0.4
P	2.4
Q	1.65



**Figure 12.3 DFN-10 Package dimensions (bottom).** Note that the saddle need to be connected to GND on the PCB.

**Table 12.3 DFN-10 Package dimensions (side)**

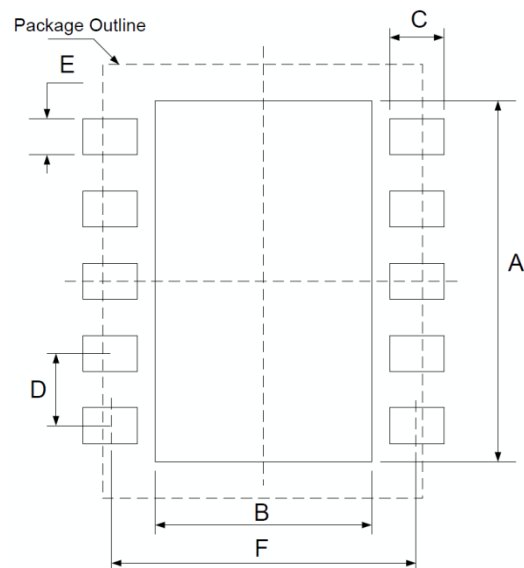
Dimension	[mm]
G	0.05
H	0.65
I	0.7-0.8



**Figure 12.4 DFN-10 Package dimensions (side)**

**Table 12.4 DFN-10 Landing dimensions**

Dimension	[mm]
A	2.4
B	1.65
C	0.8
D	0.5
E	0.3
F	3.2

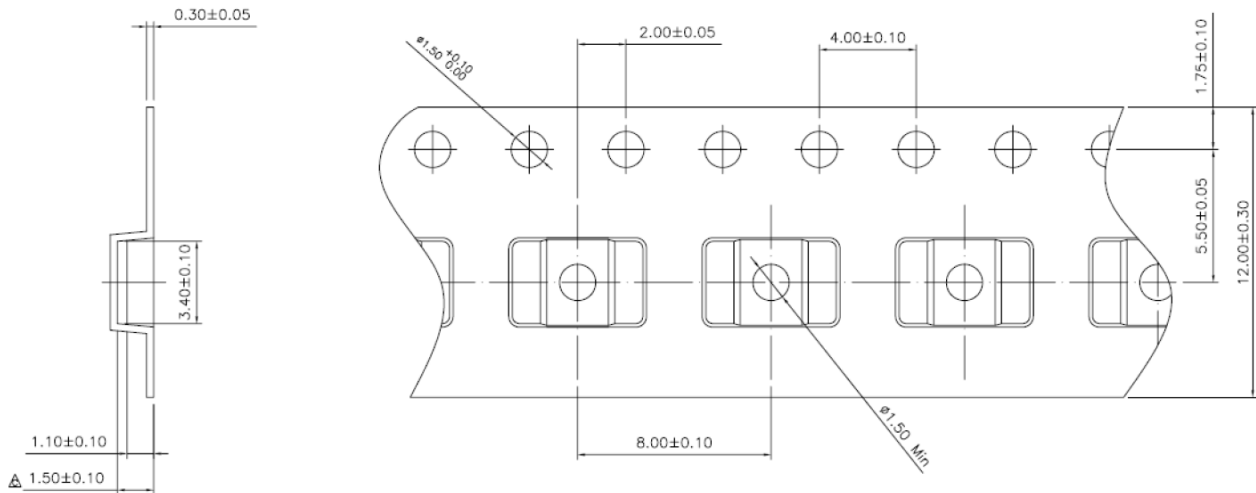


**Figure 12.5 DFN-10 Landing dimensions**



## 12.3 Tape and Reel Specification

### 12.3.1 MSOP10



#### NOTES:

1. 10 sprocket hole pitch cumulative tolerance  $\pm 0.2$
2. Camber not to exceed 1mm in 100mm
3. Material: Black conductive Polystyrene
4. Ao and Bo measured on a plane 0.3mm above the bottom of the pocket
5. Ko measured from a plane on the inside bottom of the pocket to the top surface of the carrier
6. Pocket position relative to sprocket hole measured as true position of pocket, not pocket hole.
7. Pocket center and pocket hole center must be same position

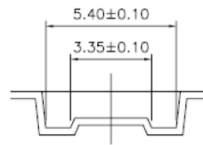
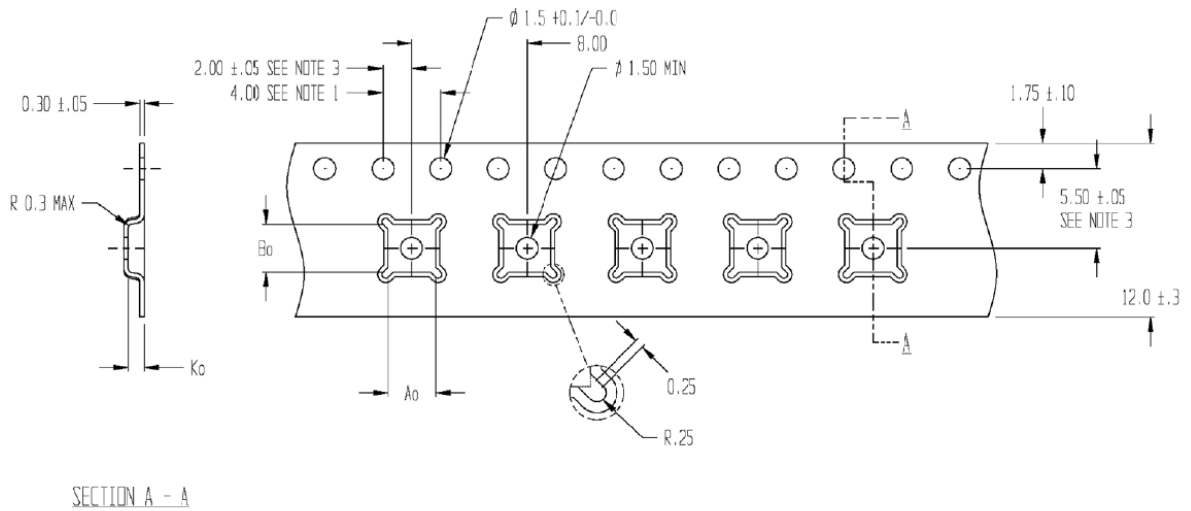


Figure 12.6 MSOP-10 Tape Specification. Bulk orientation LT.



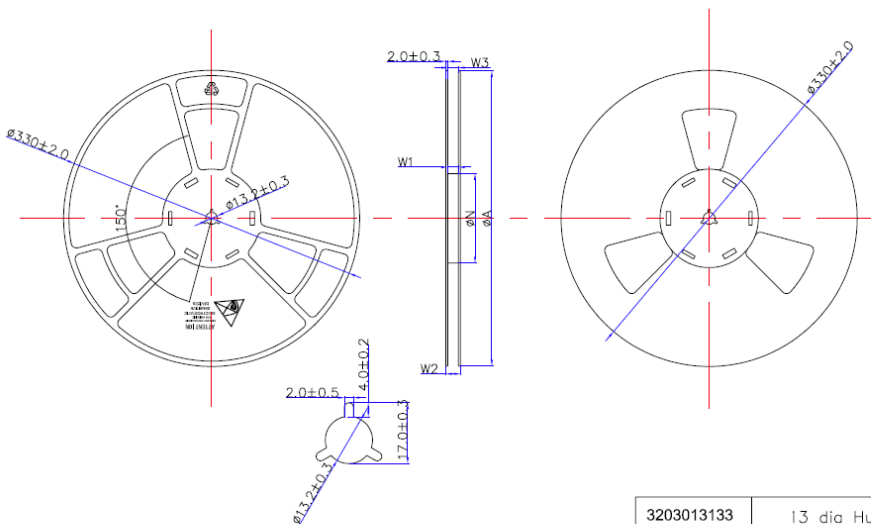
**12.3.2 DFN10 (3x3)**



**A0=3.30**  
**B0=3.30**  
**K0=1.10**

**NOTES:**

- 1、 10 SPROCKET HOLE PITCH CUMULATIVE TOLERANCE  $\pm 0.2$
- 2、 CAMBER IN COMPLIANCE WITH EIA 481
- 3、 POCKET POSITION RELATIVE TO SPROCKET HOLE  
MEASURED AS TRUE POSITION OF POCKET, NOT POCKET HOLE



PRODUCT SPECIFICATIONS					
TYPE WIDTH	ØA	ØN	W1 <sub>(Min)</sub>	W2 <sub>(Max)</sub>	W3 <sub>(Max)</sub>
12MM	330±2.0	100±1.0	12.4	18.4	15.4
16mm	330±2.0	100±1.0	16.4	22.4	19.4
24MM	330±2.0	100±1.0	24.4	30.4	27.4

3203013133	13 dia Hub4 12mm width PS B
3203013213	13 dia Hub4 16mm width PS B
3203013253	13 dia Hub4 24mm width PS B





## 12.4 Package MSL

**Moisture Sensitivity Level (MSL)** relates to the packaging and handling precautions for some semiconductors. The MSL is an electronic standard for the time period in which a moisture sensitive device can be exposed to ambient room conditions (approximately 30°C/85%RH see J-STD033C for more info) before reflow occur.

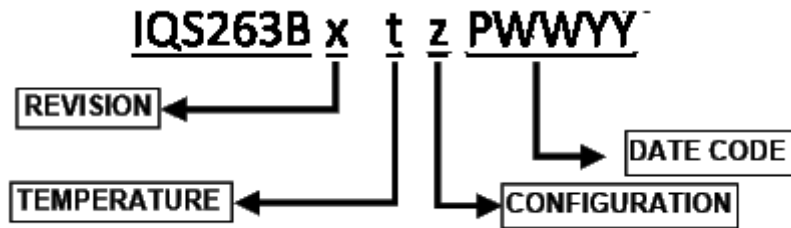
**Table 12.5 MSL**

Package	Level (duration)
MSOP-10	MSL 1 (Unlimited at $\leq 30$ °C/85% RH) Reflow profile peak temperature < 260 °C for < 25 seconds Number of Reflow $\leq 3$
DFN10 (3x3)	MSL 1 (Unlimited at $\leq 30$ °C/85% RH) Reflow profile peak temperature < 260 °C for < 25 seconds Number of Reflow $\leq 3$



## 13 Device Marking

### 13.1 Top Marking



<b>REVISION</b>	<b>x</b>	=	IC Revision Number
<b>TEMPERATURE RANGE</b>	<b>t</b>	=	i     -20°C to 85°C (Industrial)
		=	c     0°C to 70°C (Commercial)
<b>IC CONFIGURATION</b>	<b>z</b>	=	Configuration (Hexadecimal)
			Marking not present for a configuration of 0.
<b>DATE CODE</b>	<b>P</b>	=	Package House
	<b>WW</b>	=	Week
	<b>YY</b>	=	Year



## 14 Ordering Information

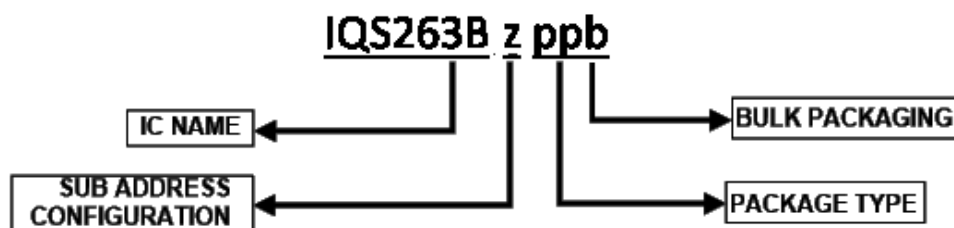
Order quantities will be subject to multiples of a full reel. Contact the official distributor for sample quantities. A list of the distributors can be found under the “Distributors” section of [www.azoteq.com](http://www.azoteq.com).

### 14.1 MSOP-10 Package



<b>IC NAME</b>	IQS263	=	IQS263
<b>CONFIGURATION</b>	z	=	Sub Address Configuration (hexadecimal) 0 = 44H 1 = 45H 2 = 46H 3 = 47H
<b>PACKAGE TYPE</b>	MS	=	MSOP-10
<b>BULK PACKAGING</b>	R	=	Reel MSOP - 4000pcs/reel

### 14.2 DFN Package



<b>IC NAME</b>	IQS263A	=	IQS263
<b>CONFIGURATION</b>	z	=	Sub Address Configuration (hexadecimal) 0 = 44H 1 = 45H 2 = 46H 3 = 47H
<b>PACKAGE TYPE</b>	DN	=	DFN10 (3x3)
<b>BULK PACKAGING</b>	R	=	Reel DNF10 (3x3) – 3000pcs/reel



## Appendix A. Contact Information

	<b>USA</b>	<b>Asia</b>	<b>South Africa</b>
<b>Physical Address</b>	6507 Jester Blvd Bldg 5, suite 510G Austin TX 78750 USA	Rm2125, Glittery City Shennan Rd Futian District Shenzhen, 518033 China	109 Main Street Paarl 7646 South Africa
<b>Postal Address</b>	6507 Jester Blvd Bldg 5, suite 510G Austin TX 78750 USA	Rm2125, Glittery City Shennan Rd Futian District Shenzhen, 518033 China	PO Box 3534 Paarl 7620 South Africa
<b>Tel</b>	+1 512 538 1995	+86 755 8303 5294 ext 808	+27 21 863 0033
<b>Fax</b>	+1 512 672 8442		+27 21 863 1512
<b>Email</b>	info@azoteq.com	info@azoteq.com	info@azoteq.com

Please visit [www.azoteq.com](http://www.azoteq.com) for a list of distributors and worldwide representation.

The following patents relate to the device or usage of the device: US 6,249,089; US 6,952,084; US 6,984,900; US 7,084,526; US 7,084,531; US 8,395,395; US 8,531,120; US 8,659,306; US 8,823,273; US 9,209,803; US 9,360,510; EP 2,351,220; EP 2,559,164; EP 2,656,189; HK 1,156,120; HK 1,157,080; SA 2001/2151; SA 2006/05363; SA 2014/01541; SA 2015/023634

IQ Switch®, SwipeSwitch™, ProxSense®, LightSense™, AirButton™, ProxFusion™, Crystal Driver™ and the  logo are trademarks of Azoteq.

The information in this Datasheet is believed to be accurate at the time of publication. Azoteq uses reasonable effort to maintain the information up-to-date and accurate, but does not warrant the accuracy, completeness or reliability of the information contained herein. All content and information are provided on an "as is" basis only, without any representations or warranties, express or implied, of any kind, including representations about the suitability of these products or information for any purpose. Values in the datasheet is subject to change without notice, please ensure to always use the latest version of this document. Application specific operating conditions should be taken into account during design and verified before mass production. Azoteq disclaims all warranties and conditions with regard to these products and information, including but not limited to all implied warranties and conditions of merchantability, fitness for a particular purpose, title and non-infringement of any third party intellectual property rights. Azoteq assumes no liability for any damages or injury arising from any use of the information or the product or caused by, without limitation, failure of performance, error, omission, interruption, defect, delay in operation or transmission, even if Azoteq has been advised of the possibility of such damages. The applications mentioned herein are used solely for the purpose of illustration and Azoteq makes no warranty or representation that such applications will be suitable without further modification, nor recommends the use of its products for application that may present a risk to human life due to malfunction or otherwise. Azoteq products are not authorized for use as critical components in life support devices or systems. No licenses to patents are granted, implicitly, express or implied, by estoppel or otherwise, under any intellectual property rights. In the event that any of the abovementioned limitations or exclusions does not apply, it is agreed that Azoteq's total liability for all losses, damages and causes of action (in contract, tort (including without limitation, negligence) or otherwise) will not exceed the amount already paid by the customer for the products. Azoteq reserves the right to alter its products, to make corrections, deletions, modifications, enhancements, improvements and other changes to the content and information, its products, programs and services at any time or to move or discontinue any contents, products, programs or services without prior notification. For the most up-to-date information and binding Terms and Conditions please refer to [www.azoteq.com](http://www.azoteq.com)

[www.azoteq.com/ip](http://www.azoteq.com/ip)

info@azoteq.com



Компания «ЭлектроПласт» предлагает заключение долгосрочных отношений при поставках импортных электронных компонентов на взаимовыгодных условиях!

Наши преимущества:

- Оперативные поставки широкого спектра электронных компонентов отечественного и импортного производства напрямую от производителей и с крупнейших мировых складов;
- Поставка более 17-ти миллионов наименований электронных компонентов;
- Поставка сложных, дефицитных, либо снятых с производства позиций;
- Оперативные сроки поставки под заказ (от 5 рабочих дней);
- Экспресс доставка в любую точку России;
- Техническая поддержка проекта, помощь в подборе аналогов, поставка прототипов;
- Система менеджмента качества сертифицирована по Международному стандарту ISO 9001;
- Лицензия ФСБ на осуществление работ с использованием сведений, составляющих государственную тайну;
- Поставка специализированных компонентов (Xilinx, Altera, Analog Devices, Intersil, Interpoint, Microsemi, Aeroflex, Peregrine, Syfer, Eurofarad, Texas Instrument, Miteq, Cobham, E2V, MA-COM, Hittite, Mini-Circuits, General Dynamics и др.);

Помимо этого, одним из направлений компании «ЭлектроПласт» является направление «Источники питания». Мы предлагаем Вам помощь Конструкторского отдела:

- Подбор оптимального решения, техническое обоснование при выборе компонента;
- Подбор аналогов;
- Консультации по применению компонента;
- Поставка образцов и прототипов;
- Техническая поддержка проекта;
- Защита от снятия компонента с производства.



#### Как с нами связаться

**Телефон:** 8 (812) 309 58 32 (многоканальный)

**Факс:** 8 (812) 320-02-42

**Электронная почта:** [org@eplast1.ru](mailto:org@eplast1.ru)

**Адрес:** 198099, г. Санкт-Петербург, ул. Калинина, дом 2, корпус 4, литера А.