

THIS DRAWING IS UNPUBLISHED. RELEASED FOR PUBLICATION
 © COPYRIGHT 2011 BY TYCO ELECTRONICS CORPORATION. ALL RIGHTS RESERVED.

LOC	DIST	REVISIONS					
DW		P	LTR	DESCRIPTION	DATE	DWN	APVD
				SEE SHEET 1.			

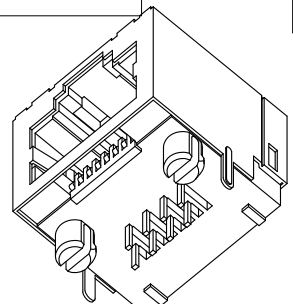

- NOTE:
- MATERIAL:
 - HOUSING: PA46, WITH 30% GF, UL94V-0, BLACK COLOR.
 - CONTACTS: PHOSPHOR BRONZE.
 - SHELL: BRASS.
 - FINISH:
 - CONTACTS: (SEE TABLE) GOLD PLATED ON CONTACT AREA, GOLD FLASH ON SOLDER TAIL, 1.27um [50u"] MIN. NICKEL UNDERPLATED OVERALL.
 - SHELL: 0.508um [20u"] MIN. NICKEL PLATED.
 - WAVE SOLDER CAPABLE TO 265°C PER TE SPEC 109-202, CONDITION B.

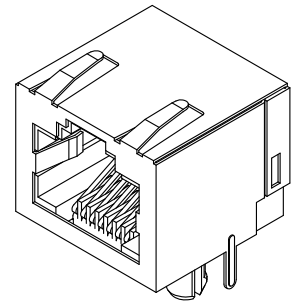
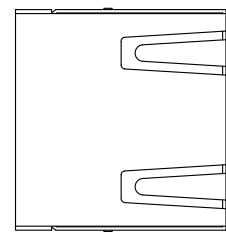
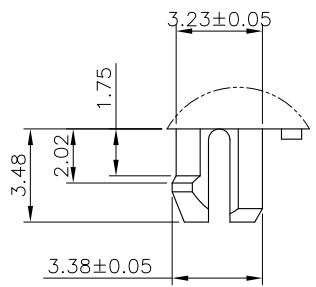
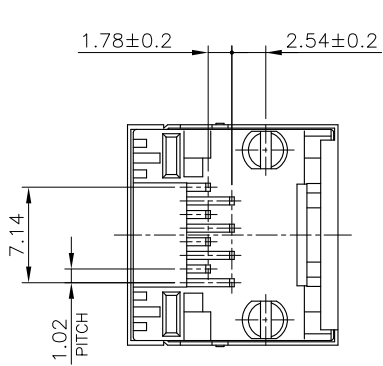
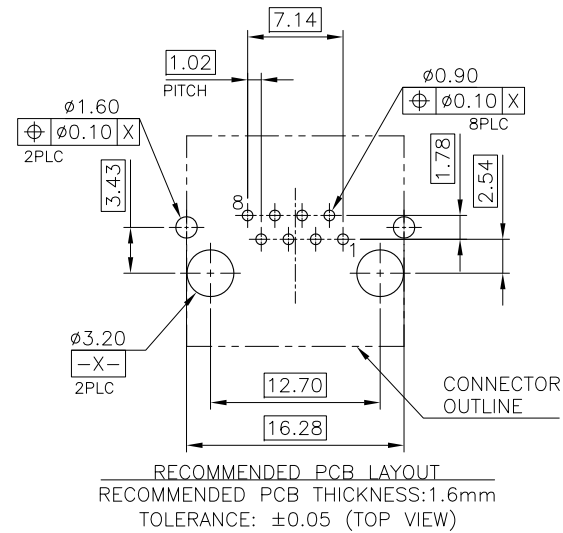
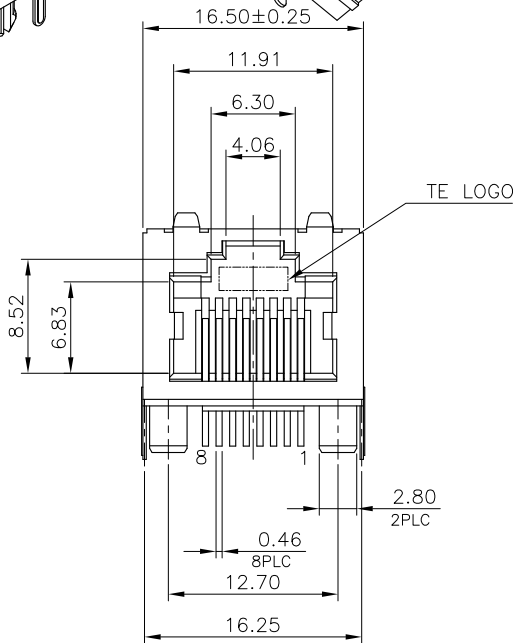
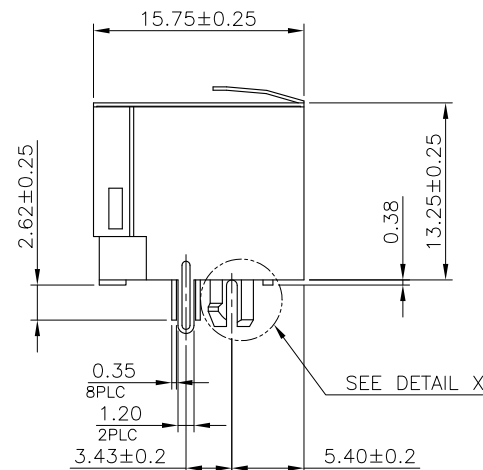

DETAIL X
SCALE 2:1

OBSOLETE A	1.27um[50u"]	1-1775134-4
	0.76um[30u"]	1-1775134-3
	0.38um[15u"]	1-1775134-2
	0.15um[6u"]	1-1775134-1
	MIN. GOLD THICKNESS	PART NUMBER

THIS DRAWING IS A CONTROLLED DOCUMENT.		DWN	TE Connectivity		
DIMENSIONS: mm		CHK	NAME		
TOLERANCES UNLESS OTHERWISE SPECIFIED:		APVD	MODULAR JACK, RJ455, SINGLE		
0 PLC ± -		PRODUCT SPEC	SIZE	CAGE CODE	DRAWING NO
1 PLC ± 0.3		APPLICATION SPEC	A3	00779	C=1775134
2 PLC ± 0.2		WEIGHT	RESTRICTED TO		
3 PLC ± 0.15		CUSTOMER DRAWING	SCALE	SHEET	REV
4 PLC ± -				2 of 4	A2
ANGLES ± 3'					
MATERIAL	FINISH				

THIS DRAWING IS UNPUBLISHED. RELEASED FOR PUBLICATION
 © COPYRIGHT 2011 BY TYCO ELECTRONICS CORPORATION. ALL RIGHTS RESERVED.

LOC		DIST		REVISIONS					
DW				P	LTR	DESCRIPTION	DATE	DWN	APVD
SEE SHEET 1.									

D

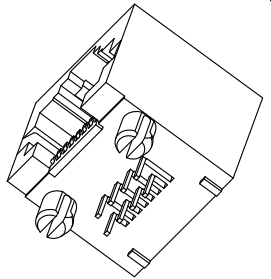
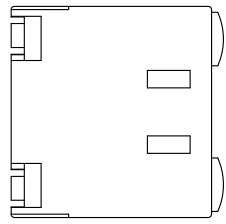

- NOTE:
- MATERIAL:
 - HOUSING: PA46, WITH 30% GF, UL94V-0, BLACK COLOR.
 - CONTACTS: PHOSPHOR BRONZE.
 - LED SOLDER TAIL: EPOXY, STEEL.
 - FINISH:
 - CONTACTS: (SEE TABLE) GOLD PLATED ON CONTACT AREA, GOLD FLASH ON SOLDER TAIL, 1.27um [50u"] MIN. NICKEL UNDERPLATED OVERALL.
 - LED: 1.016um [40u"] COPPER UNDERPLATED OVERALL. 1.27um [50u"] NICKEL OVERALL. 1.27um [50u"] SILVER ON BONDING AREA. 2.54um [100u"] BRIGHT-TIN ON SOLDER AREA.
 - WAVE SOLDER CAPABLE TO 265°C PER TE SPEC 109-202, CONDITION B.

C

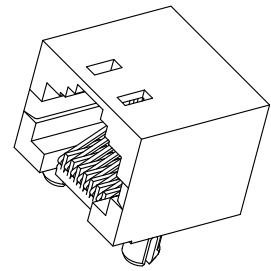
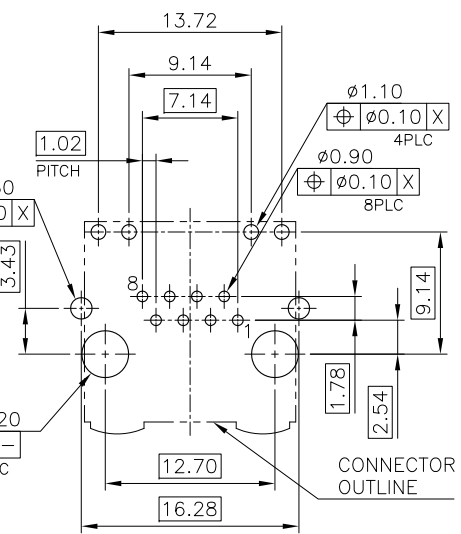
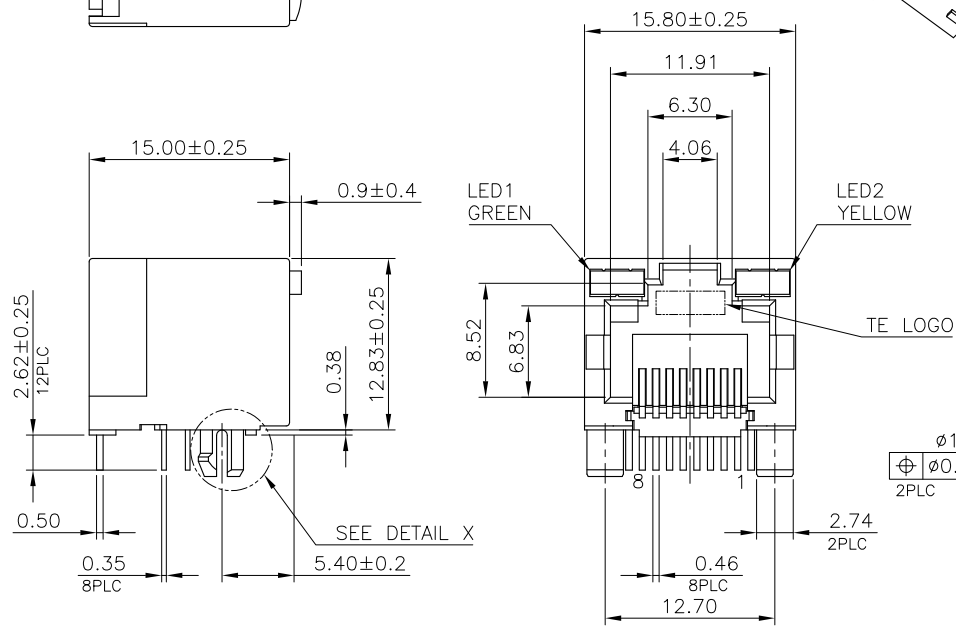

B

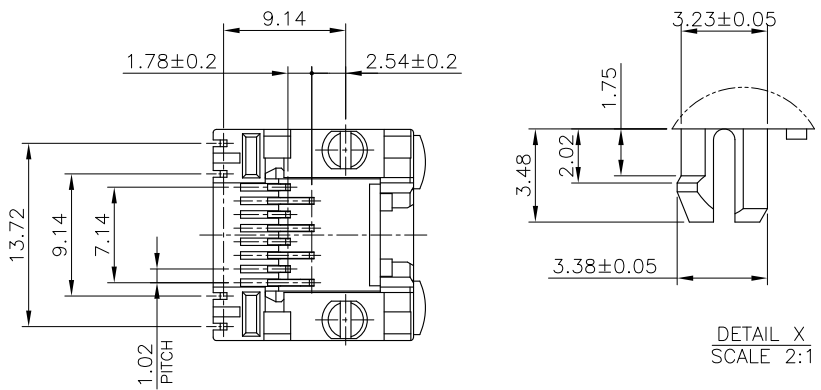

RECOMMENDED PCB LAYOUT
 RECOMMENDED PCB THICKNESS: 1.6mm
 TOLERANCE: ±0.05 (TOP VIEW)

OBSOLETE A	1.27um[50u"]	2-1775134-4
	0.76um[30u"]	2-1775134-3
	0.38um[15u"]	2-1775134-2
	0.15um[6u"]	2-1775134-1
	MIN. GOLD THICKNESS	PART NUMBER

A

THIS DRAWING IS A CONTROLLED DOCUMENT.		DWN	TE Connectivity		
DIMENSIONS: mm		CHK	NAME		
TOLERANCES UNLESS OTHERWISE SPECIFIED:		APVD	MODULAR JACK, RJ455, SINGLE		
0 PLC ± -		PRODUCT SPEC	SIZE	CAGE CODE	DRAWING NO
1 PLC ± 0.3		APPLICATION SPEC	A3	00779	C=1775134
2 PLC ± 0.2		WEIGHT	RESTRICTED TO		
3 PLC ± 0.15		CUSTOMER DRAWING	SCALE		
4 PLC ± -			SHEET 3 of 4		
ANGLES ± 3'			REV A2		
MATERIAL	FINISH				

THIS DRAWING IS UNPUBLISHED. RELEASED FOR PUBLICATION
 © COPYRIGHT 2011 BY TYCO ELECTRONICS CORPORATION. ALL RIGHTS RESERVED.

LOC DW	DIST	REVISIONS			
P	LTR	DESCRIPTION	DATE	DWN	APVD
		SEE SHEET 1.			

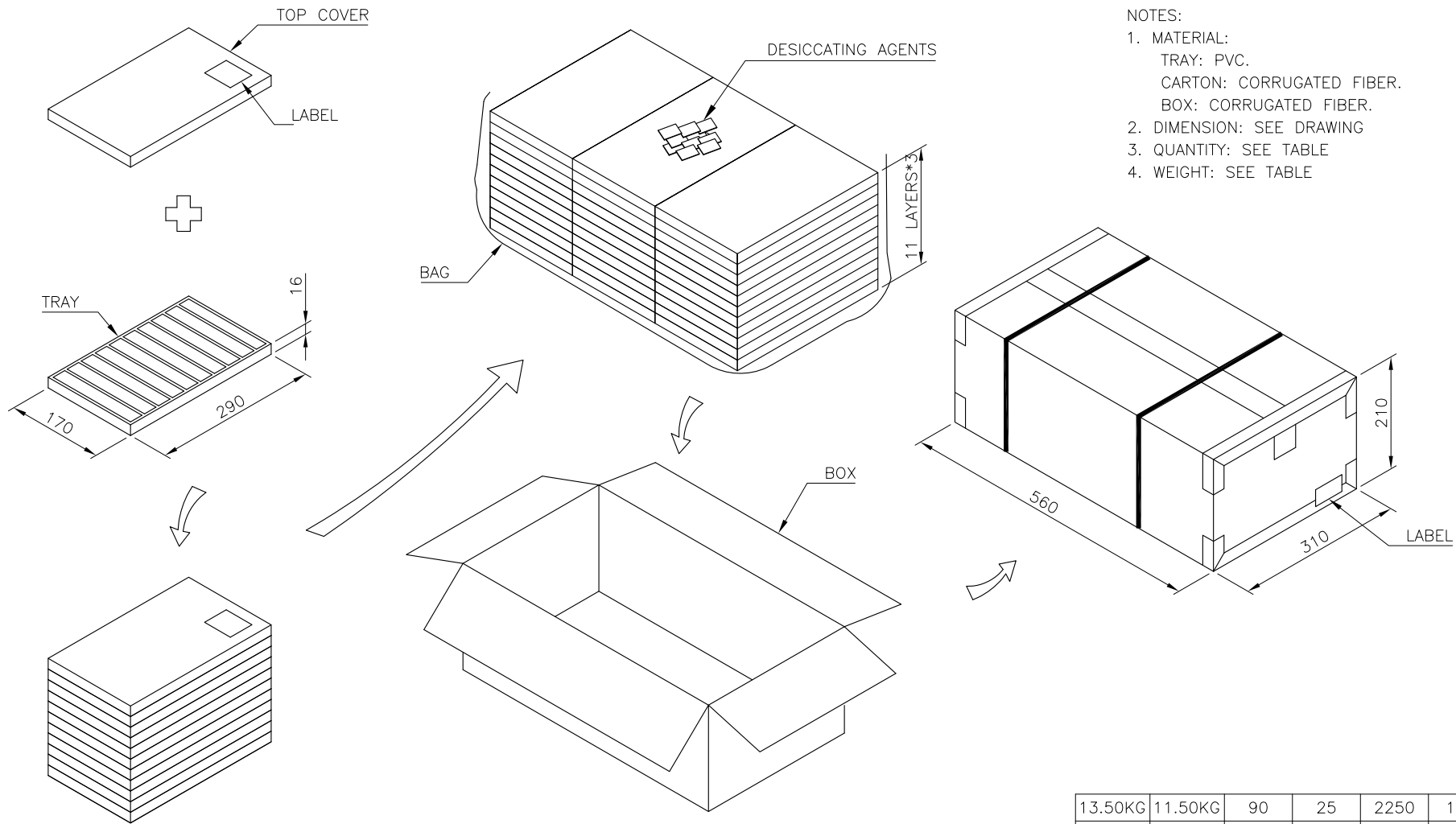

- NOTES:
- MATERIAL:
 TRAY: PVC.
 CARTON: CORRUGATED FIBER.
 BOX: CORRUGATED FIBER.
 - DIMENSION: SEE DRAWING
 - QUANTITY: SEE TABLE
 - WEIGHT: SEE TABLE

13.50KG	11.50KG	90	25	2250	1775134-X
GROSS WEIGHT	NET WEIGHT	PCS/ TRAY	TRAY/ BOX	PCS/ BOX	PART NUMBER

THIS DRAWING IS A CONTROLLED DOCUMENT.		DWN	TE Connectivity					
DIMENSIONS: mm		CHK				NAME		
TOLERANCES UNLESS OTHERWISE SPECIFIED:		APVD				PRODUCT SPEC		
0 PLC ± - 1 PLC ± 0.3 2 PLC ± 0.2 3 PLC ± 0.15 4 PLC ANGLES ± - ± 3°		APVD				APPLICATION SPEC		
MATERIAL	FINISH	WEIGHT	SIZE	CAGE CODE	DRAWING NO	RESTRICTED TO		
			A3	00779	C=1775134			
CUSTOMER DRAWING			SCALE	SHEET	4 of 4	REV A2		



Компания «ЭлектроПласт» предлагает заключение долгосрочных отношений при поставках импортных электронных компонентов на взаимовыгодных условиях!

Наши преимущества:

- Оперативные поставки широкого спектра электронных компонентов отечественного и импортного производства напрямую от производителей и с крупнейших мировых складов;
- Поставка более 17-ти миллионов наименований электронных компонентов;
- Поставка сложных, дефицитных, либо снятых с производства позиций;
- Оперативные сроки поставки под заказ (от 5 рабочих дней);
- Экспресс доставка в любую точку России;
- Техническая поддержка проекта, помощь в подборе аналогов, поставка прототипов;
- Система менеджмента качества сертифицирована по Международному стандарту ISO 9001;
- Лицензия ФСБ на осуществление работ с использованием сведений, составляющих государственную тайну;
- Поставка специализированных компонентов (Xilinx, Altera, Analog Devices, Intersil, Interpoint, Microsemi, Aeroflex, Peregrine, Syfer, Eurofarad, Texas Instrument, Miteq, Cobham, E2V, MA-COM, Hittite, Mini-Circuits, General Dynamics и др.);

Помимо этого, одним из направлений компании «ЭлектроПласт» является направление «Источники питания». Мы предлагаем Вам помощь Конструкторского отдела:

- Подбор оптимального решения, техническое обоснование при выборе компонента;
- Подбор аналогов;
- Консультации по применению компонента;
- Поставка образцов и прототипов;
- Техническая поддержка проекта;
- Защита от снятия компонента с производства.



Как с нами связаться

Телефон: 8 (812) 309 58 32 (многоканальный)

Факс: 8 (812) 320-02-42

Электронная почта: org@eplast1.ru

Адрес: 198099, г. Санкт-Петербург, ул. Калинина, дом 2, корпус 4, литера А.