

Temperature measuring transducer - MACX PL-T-UIREL-UP - 2904901

Please be informed that the data shown in this PDF Document is generated from our Online Catalog. Please find the complete data in the user's documentation. Our General Terms of Use for Downloads are valid (<http://phoenixcontact.com/download>)



Freely programmable temperature transducer with analog output and 3 limit value relays, standard configuration, resistance thermometer with 2, 3 or 4-conductor technology, thermocouples, electrical isolation, wide-range power supply, screw connection, PLd

Product Features



Key commercial data

Packing unit	1 pc
Custom tariff number	85437090
Country of origin	Germany

Technical data

Note

Utilization restriction	EMC: class A product, see manufacturer's declaration in the download area
-------------------------	---

Dimensions

Width	35 mm
Height	99 mm
Depth	114.5 mm

Ambient conditions

Ambient temperature (operation)	-20 °C ... 65 °C
Ambient temperature (storage/transport)	-40 °C ... 85 °C
Maximum altitude	≤ 2000 m
Permissible humidity (operation)	typ. 5 % ... 95 % (non-condensing)

Temperature measuring transducer - MACX PL-T-UIREL-UP - 2904901

Technical data

Ambient conditions

Noise immunity	EN 61000-6-2 When being exposed to interference, there may be minimal deviations.
----------------	---

Input data

Sensor types (RTD) that can be used	Pt, Ni, Cu sensors: 2, 3, 4-wire
Sensor types that can be used (TC)	B, E, J, K, N, R, S, T, L, U, CA, DA, A1G, A2G, A3G, MG, LG
Temperature measuring range	-200 °C ... 850 °C
Input signal range	0 Ω ... 50 kΩ
Potentiometer resistance range	0 Ω ... 50 kΩ
Input signal range	-1000 mV ... 1000 mV

Output data

Current output signal	4 mA ... 20 mA
Max. current output signal	22 mA
Load/output load current output	≤ 600 Ω (at 20 mA)
Behavior in the event of a sensor error	according to NE 43 or freely configurable
Output name	Relay output
Output description	1 SIL/PL
Contact type	2 PDT
Contact material	AgSnO ₂ , hard gold-plated
Maximum switching voltage	250 V AC (250 V DC)
Maximum inrush current	2 A (250 V AC)
	2 A (28 V DC)
	0.2 A (120 V DC)

Power supply

Supply voltage range	24 V ... 230 V AC/DC (-20 %/+10 %, 50/60 Hz)
Power consumption	< 2.4 W

Connection data

Conductor cross section solid min.	0.2 mm ²
Conductor cross section solid max.	2.5 mm ²
Conductor cross section flexible min.	0.2 mm ²
Conductor cross section flexible max.	2.5 mm ²
Conductor cross section AWG min.	24
Conductor cross section AWG max.	14
Screw thread	M3
Connection method	Screw connection

General

Temperature measuring transducer - MACX PL-T-UIREL-UP - 2904901

Technical data

General

Maximum transmission error	0.1 % (e.g. for Pt 100, 300 K span, 4 ... 20 mA)
Maximum temperature coefficient	0.01 %/K
Inflammability class according to UL 94	V0
Pollution degree	2
Surge voltage category	II
Housing material	PA 66-FR
Color	yellow
Designation	Input/output/power supply
Electrical isolation	300 V _{rms} (Rated insulation voltage (surge voltage category II; pollution degree 2, safe isolation as per EN 61010-1))
	2.5 kV (50 Hz, 1 min., test voltage)
Designation	Input/output
Electrical isolation	375 V (Peak value in accordance with EN 60079-11)
Designation	Input/power supply
Electrical isolation	375 V (Peak value in accordance with EN 60079-11)
Designation	Input/switching output
Electrical isolation	375 V (Peak value in accordance with EN 60079-11)
Conformance	CE-compliant
ATEX	# II 3 G Ex nA nC ic IIC T4 Gc X
IECEX	Ex nA nC ic IIC T4 Gc X
UL, USA / Canada	UL 508 Listed
	Class I, Div. 2, Groups A, B, C, D T6
	Class I, Zone 2, Group IIC T6
Functional Safety (SIL)	SIL 2

Classifications

eCl@ss

eCl@ss 5.1	27210107
eCl@ss 6.0	27210120

ETIM

ETIM 4.0	EC002653
ETIM 5.0	EC002653

Approvals

Approvals

Temperature measuring transducer - MACX PL-T-UIREL-UP - 2904901

Approvals

Approvals

UL Listed / cUL Listed / GL / Functional Safety / cULus Listed

Ex Approvals

ATEX / IECEx / UL Listed / cUL Listed / cULus Listed

Approvals submitted

Approval details

UL Listed 

cUL Listed 

GL

Functional Safety

cULus Listed 

Drawings

Temperature measuring transducer - MACX PL-T-UIREL-UP - 2904901

Block diagram

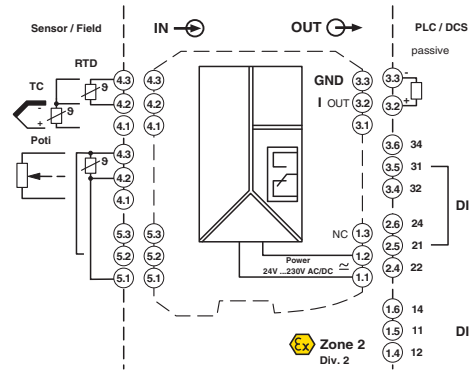



Компания «ЭлектроПласт» предлагает заключение долгосрочных отношений при поставках импортных электронных компонентов на взаимовыгодных условиях!

Наши преимущества:

- Оперативные поставки широкого спектра электронных компонентов отечественного и импортного производства напрямую от производителей и с крупнейших мировых складов;
- Поставка более 17-ти миллионов наименований электронных компонентов;
- Поставка сложных, дефицитных, либо снятых с производства позиций;
- Оперативные сроки поставки под заказ (от 5 рабочих дней);
- Экспресс доставка в любую точку России;
- Техническая поддержка проекта, помощь в подборе аналогов, поставка прототипов;
- Система менеджмента качества сертифицирована по Международному стандарту ISO 9001;
- Лицензия ФСБ на осуществление работ с использованием сведений, составляющих государственную тайну;
- Поставка специализированных компонентов (Xilinx, Altera, Analog Devices, Intersil, Interpoint, Microsemi, Aeroflex, Peregrine, Syfer, Eurofarad, Texas Instrument, Miteq, Cobham, E2V, MA-COM, Hittite, Mini-Circuits, General Dynamics и др.);

Помимо этого, одним из направлений компании «ЭлектроПласт» является направление «Источники питания». Мы предлагаем Вам помощь Конструкторского отдела:

- Подбор оптимального решения, техническое обоснование при выборе компонента;
- Подбор аналогов;
- Консультации по применению компонента;
- Поставка образцов и прототипов;
- Техническая поддержка проекта;
- Защита от снятия компонента с производства.



Как с нами связаться

Телефон: 8 (812) 309 58 32 (многоканальный)

Факс: 8 (812) 320-02-42

Электронная почта: org@eplast1.ru

Адрес: 198099, г. Санкт-Петербург, ул. Калинина, дом 2, корпус 4, литера А.