

ICs for use with low voltage Crystal Oscillators

■ GENERAL DESCRIPTION

The XC2165 series is a CMOS IC operates in 1.5V to 3.6V with the built-in circuits for crystal oscillator and divider.

Output is selectable from any one of f₀, f₀/1, f₀/2, f₀/4 and f₀/8.

With oscillation capacitors and a feedback resistor built-in, it is possible to configure a stable fundamental oscillator using only an external crystal.

In stand-by mode, oscillation stops completely and output pin Q0 becomes high impedance.

The XC2165 series is available in SOT-26 package.

■ APPLICATIONS

- Crystal oscillation modules
- Micro computers, DSP clocks
- Communication equipment
- Various system clocks
- Cellular and portable phones

■ FEATURES

Oscillation Frequency	:	8MHz~120MHz (Fundamental)
Divider Ratio	:	f ₀ /1, f ₀ /2, f ₀ /4, f ₀ /8
Output	:	3-State
Operating Voltage Range	:	1.5V ~ 3.6V
Low Current Consumption	:	Stand-by function included : 30 μA (MAX.) when stand-by
Built-in Capacitors C_g, C_d		
Built-in Feedback Resistor		
Operating Ambient Temperature	:	- 40°C~ + 85°C
Package	:	SOT-26
Environmentally Friendly	:	EU RoHS Compliant, Pb Free

■ PIN CONFIGURATION

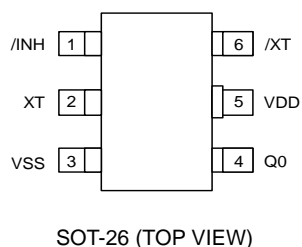

■ PIN ASSIGNMENT

PIN NUMBER	PIN NAME	FUNCTIONS
1	/INH	Stand-by Control *
2	XT	Crystal Oscillator Connection (Input)
3	VSS	Ground
4	Q0	Clock Output
5	VDD	Power Supply
6	/XT	Crystal Oscillator Connection (Output)

* Pull-up resistor is built-in to the stand-by control pin.

■ BLOCK DIAGRAM

1). XC2165C21Axx/XC2165C21Bxx ($f_{OSC} = f_0/1$)

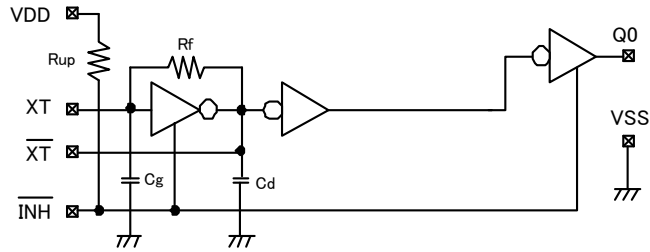

2). XC2165C22Axx/XC2165C22Bxx ($f_{OSC} = f_0/2$)

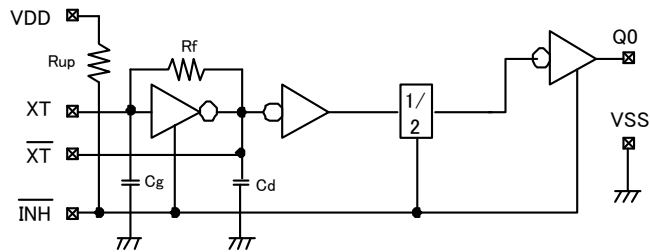

3). XC2165C24Axx/XC2165C24Bxx ($f_{OSC} = f_0/4$)

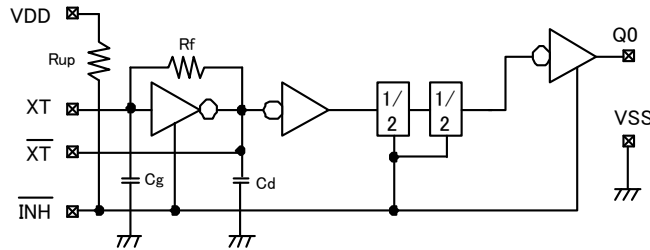

4). XC2165C28Axx/XC2165C28Bxx ($f_{OSC} = f_0/8$)

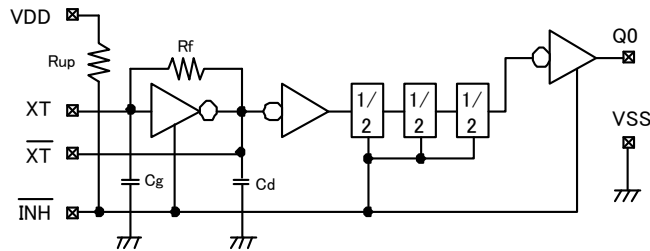

■ PRODUCT CLASSIFICATION

● Ordering Information

XC2165 ①②③④⑤⑥-⑦

DESIGNATOR	ITEM	SYMBOL	DESCRIPTION
①	Duty Level	C	CMOS
②	Fixed Number	2	-
③	Divider Ratio	1	f0/1
		2	f0/2
		4	f0/4
		8	f0/8
④	Oscillation Frequency	A	8MHz ~ 70MHz
		B	16MHz ~ 120MHz
⑤⑥-⑦ ^(*)	Package(Order Unit)	MR	SOT-26(3,000/Reel)
		MR-G	SOT-26(3,000/Reel)

(*) The "-G" suffix denotes Halogen and Antimony free as well as being fully RoHS compliant.

■ PIN FUNCTION

/ INH	Q0
'H' or Open	Clock Output
'L'	High Impedance

■ ABSOLUTE MAXIMUM RATINGS

Ta=25°C

PARAMETER	SYMBOL	RATINGS	UNITS
Supply Voltage	V _{DD}	V _{SS} – 0.3 to V _{SS} + 7.0	V
/ INH Pin Voltage	V _{INH}	V _{SS} – 0.3 to V _{DD} + 0.3	V
Q0 Pin Voltage	V _{Q0}	V _{SS} – 0.3 to V _{DD} + 0.3	V
Q0 Output Current	I _{Q0}	± 50	mA
Power Dissipation	P _d	250	mW
Operating Ambient Temperature	T _{opr}	- 40 to + 85	°C
Storage Temperature	T _{stg}	- 55 to + 125	°C

DC ELECTRICAL CHARACTERISTICS

XC2165C2xAxx

1.8V Operation (Unless otherwise stated, V_{DD} = 1.8V, f₀=70MHz, No Load, Ta = - 40°C ~ + 85°C)

PARAMETER	SYMBOL	FUNCTION	MIN.	TYP.	MAX.	UNIT	CIRCUIT	
Operating Voltage	V _{DD}		1.5	1.8	3.6	V	-	
Crystal Oscillation Frequency	f ₀		8	-	70	MHz	-	
Output Frequency	f _{OSC}	MIN : f ₀ =8MHz, MAX : f ₀ =70MHz, C _L =15pF	XC2165C21Axx	8	-	70	MHz	-
			XC2165C22Axx	4	-	35		
			XC2165C24Axx	2	-	17.5		
			XC2165C28Axx	1	-	8.75		
'H' Level Input Voltage	V _{IH}	/INH pin	0.7V _{DD}	-	-	V	1	
'L' Level Input Voltage	V _{IL}	/INH pin	-	-	0.3V _{DD}	V	1	
'H' Level Output Voltage	V _{OH}	Q0 pin, V _{DD} =1.5V, I _{OH} = - 2.0mA	1.0	1.1	-	V	2	
'L' Level Output Voltage	V _{OL}	Q0 pin, V _{DD} =1.5V, I _{OL} = 2.0mA	-	0.3	0.4	V	2	
Supply Current 1	I _{DD1}	/INH =Open, C _L =15pF	XC2165C21Axx	-	5.0	10.0	mA	3
			XC2165C22Axx	-	3.5	7.0		
			XC2165C24Axx	-	3.0	6.0		
			XC2165C28Axx	-	2.5	6.0		
Supply Current 2	I _{DD2}	/INH = 'L', f ₀ = 70MHz, C _L =15pF	-	15	30	μA	3	
Input Pull-Up Resistance 1	R _{up1}	/INH = 'L'	0.8	2.0	6.0	MΩ	4	
Input Pull-Up Resistance 2	R _{up2}	/INH = 0.7V _{DD}	20.0	50.0	150.0	kΩ	4	
Internal Oscillation Capacity	C _g		-	10 ^(*)	-	pF	-	
	C _d		-	10 ^(*)	-	pF	-	
Internal Oscillation Feedback Resistance	R _f		1.2	3.0	5.5	MΩ	5	
Output Off Leak Current	I _{oz}	V _{DD} =3.6V, /INH = 'L'	-	-	1.0	μA	6	

(*) Designed value

AC ELECTRICAL CHARACTERISTICS

XC2165C2xAxx

1.8V Operation (Unless otherwise stated, V_{DD} = 1.8V, f₀=70MHz, C_L=15pF, Ta = - 40°C ~ + 85°C)

PARAMETER	SYMBOL	FUNCTION	MIN.	TYP.	MAX.	UNIT	CIRCUIT
Output Rise Time	t _r	V _{DD} =1.8V, C _L =15pF (10% to 90%)	-	-	6.5 ^(*)	ns	-
Output Fall Time	t _f	V _{DD} =1.8V, C _L =15pF (10% to 90%)	-	-	6.5 ^(*)	ns	-
Duty Cycle	DUTY	C _L =15pF @ 0.5V _{DD}	40	-	60	%	7
Output Start Time	t _{on}	f ₀ =8MHz	-	-	4.0 ^(*)	ms	-

(*) Designed value

■ DC ELECTRICAL CHARACTERISTICS (Continued)

XC2165C2xBxx

2.5V Operation (Unless otherwise stated, V_{DD} = 2.5V, f₀=120MHz, No Load, Ta = - 40°C ~ + 85°C)

PARAMETER	SYMBOL	FUNCTION	MIN.	TYP.	MAX.	UNIT	CIRCUIT	
Operating Voltage	V _{DD}		1.8	2.5	3.6	V	-	
Crystal Oscillation Frequency	f ₀		16	-	120	MHz	-	
Output Frequency	f _{OSC}	MIN : f ₀ =16MHz, MAX : f ₀ =120MHz, C _L =5pF	XC2165C21Bxx	16	-	120	MHz	-
			XC2165C22Bxx	8	-	60		
			XC2165C24Bxx	4	-	30		
			XC2165C28Bxx	2	-	15		
'H' Level Input Voltage	V _{IH}	/INH pin	0.7V _{DD}	-	-	V	1	
'L' Level Input Voltage	V _{IL}	/INH pin	-	-	0.3V _{DD}	V	1	
'H' Level Output Voltage	V _{OH}	Q0 pin, V _{DD} =1.8V, I _{OH} = - 2.0mA	1.3	1.4	-	V	2	
'L' Level Output Voltage	V _{OL}	Q0 pin, V _{DD} =1.8V, I _{OL} = 2.0mA	-	0.3	0.4	V	2	
Supply Current 1	I _{DD1}	/INH =Open, f ₀ =120MHz, C _L =5pF	XC2165C21Bxx	-	10.0	20.0	mA	3
			XC2165C22Bxx	-	T.B.D.	T.B.D.		
			XC2165C24Bxx	-	T.B.D.	T.B.D.		
			XC2165C28Bxx	-	T.B.D.	T.B.D.		
Supply Current 2	I _{DD2}	/INH = 'L', f ₀ = 120MHz, C _L =5pF	-	15.0	30.0	μA	3	
Input Pull-Up Resistance 1	R _{up1}	/INH = 'L'	0.8	2.0	6.0	MΩ	4	
Input Pull-Up Resistance 2	R _{up2}	/INH = 0.7V _{DD}	20.0	50.0	150.0	kΩ	4	
Internal Oscillation Capacity	C _g		-	10 ^(*)	-	pF	-	
	C _d		-	10 ^(*)	-	pF	-	
Internal Oscillation Feedback Resistance	R _f		1.2	3.0	5.5	MΩ	5	
Output Off Leak Current	I _{oz}	V _{DD} =3.6V, /INH = 'L'	-	-	1.0	μA	6	

(*) Designed value

■ AC ELECTRICAL CHARACTERISTICS (Continued)

XC2165C2xBxx

2.7V Operation (Unless otherwise stated, V_{DD} = 2.7V, f₀=120MHz, C_L=5pF, Ta = - 40°C ~ + 85°C)

PARAMETER	SYMBOL	FUNCTION	MIN.	TYP.	MAX.	UNIT	CIRCUIT
Output Rise Time	t _r	V _{DD} =2.5V, C _L =5pF (10% to 90%)	-	-	4.0 ^(*)	ns	-
Output Fall Time	t _f	V _{DD} =2.5V, C _L =5pF (10% to 90%)	-	-	4.0 ^(*)	ns	-
Duty Cycle	DUTY	C _L =5pF @ 0.5V _{DD}	40	-	60	%	7
Oscillation Start Time	t _{osc_on}	f ₀ =16MHz	-	-	3.0 ^(*)	ms	-

(*) Designed value

SWITCHING CHARACTERISTICS MEASUREMENT WAVEFORMS

(1) Output Rise Time: t_r / Output Fall Time: t_f

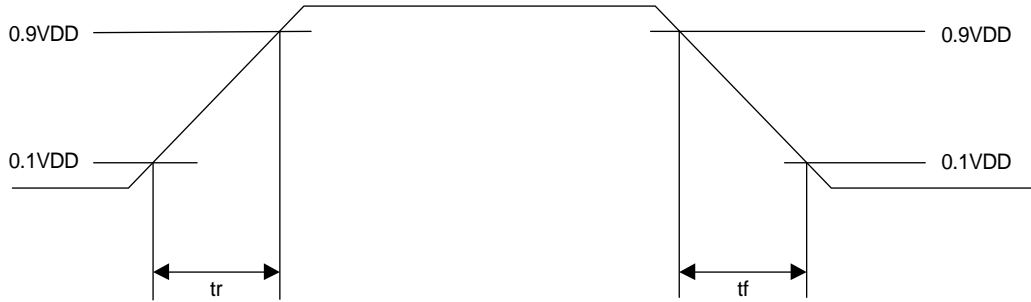

(2) Duty Cycle

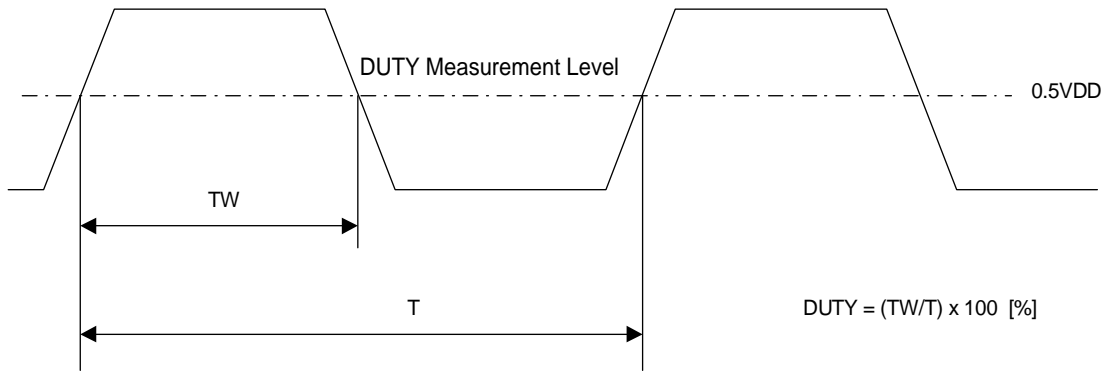

(3) Oscillation Start Time: t_{osc_on} / Oscillation Stop Time: t_{osc_off}

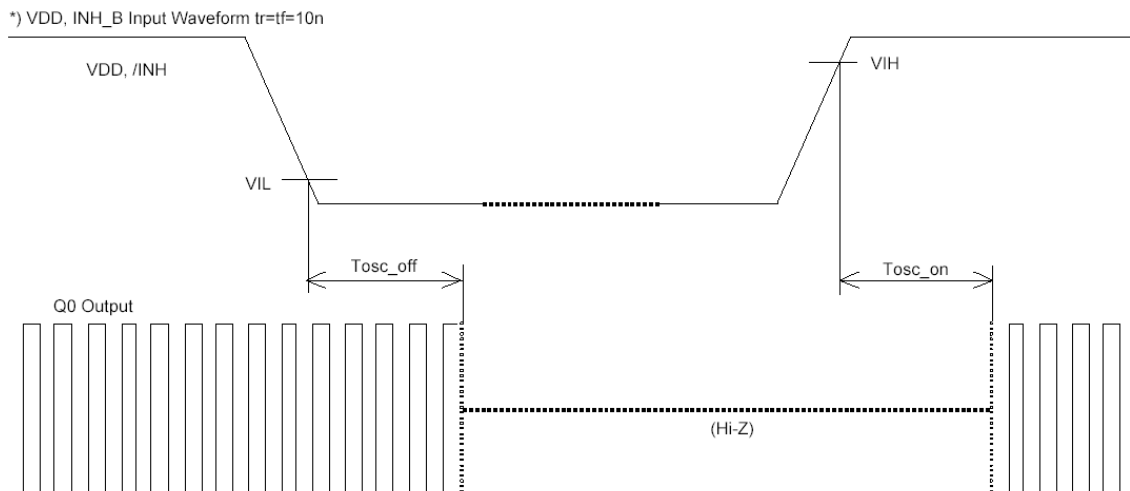

PACKAGING INFORMATION

●SOT-26

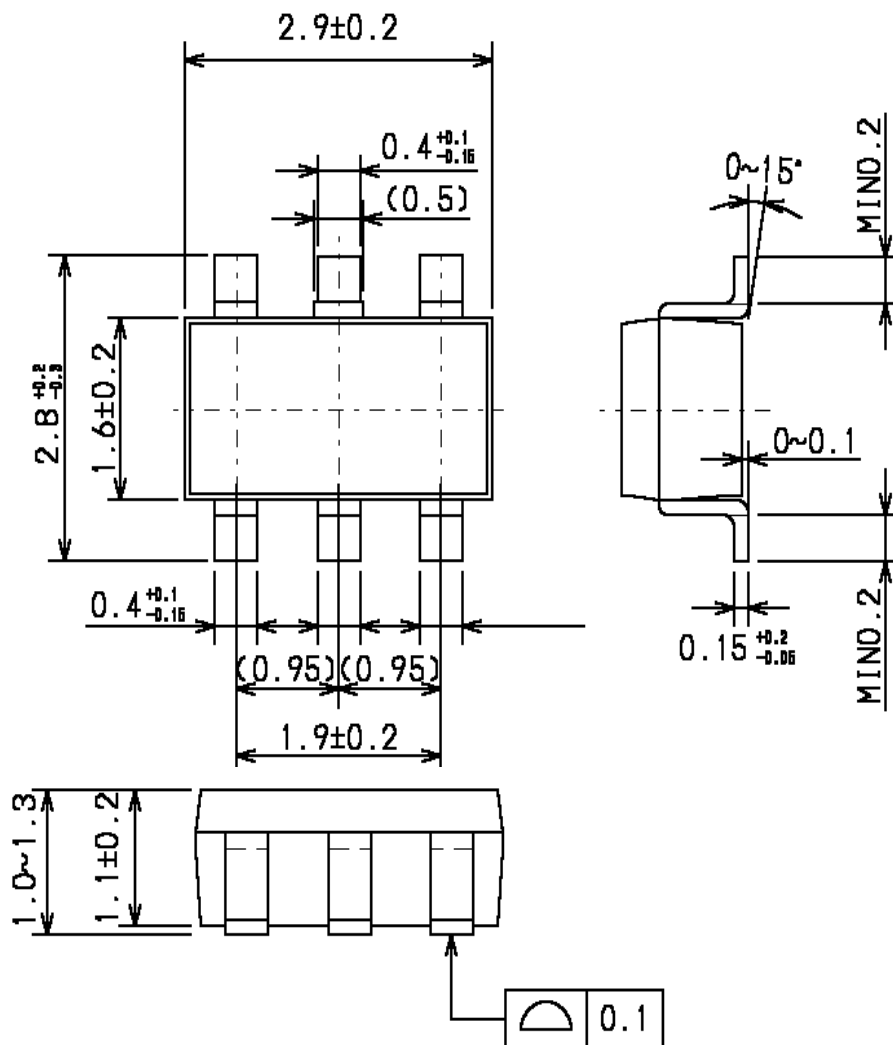

MARKING RULE

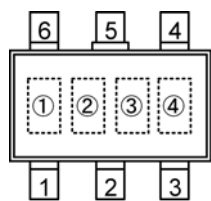

SOT-26 (TOP VIEW)

① represents product series (Fixed marking)

MARK	PRODUCT SERIES
5	XC2165 series

② represents oscillation frequency

MARK	OSCILLATION FREQUENCY
A	C2xA: 8MHz ~ 70MHz (Fundamental)
B	C2xB: 16MHz ~ 120MHz (Fundamental)

③ represents divider ratio

MARK	DEVIDER RATIO	MARK	DEVIDER RATIO
A	f0/1	B	f0/2
C	f0/4	D	f0/8

④ represents assembly lot number
(based on internal standards)

1. The products and product specifications contained herein are subject to change without notice to improve performance characteristics. Consult us, or our representatives before use, to confirm that the information in this catalog is up to date.
2. We assume no responsibility for any infringement of patents, patent rights, or other rights arising from the use of any information and circuitry in this catalog.
3. Please ensure suitable shipping controls (including fail-safe designs and aging protection) are in force for equipment employing products listed in this catalog.
4. The products in this catalog are not developed, designed, or approved for use with such equipment whose failure or malfunction can be reasonably expected to directly endanger the life of, or cause significant injury to, the user.
(e.g. Atomic energy; aerospace; transport; combustion and associated safety equipment thereof.)
5. Please use the products listed in this catalog within the specified ranges.
Should you wish to use the products under conditions exceeding the specifications, please consult us or our representatives.
6. We assume no responsibility for damage or loss due to abnormal use.
7. All rights reserved. No part of this catalog may be copied or reproduced without the prior permission of Torex Semiconductor Ltd.

TOREX SEMICONDUCTOR LTD.



Компания «ЭлектроПласт» предлагает заключение долгосрочных отношений при поставках импортных электронных компонентов на взаимовыгодных условиях!

Наши преимущества:

- Оперативные поставки широкого спектра электронных компонентов отечественного и импортного производства напрямую от производителей и с крупнейших мировых складов;
- Поставка более 17-ти миллионов наименований электронных компонентов;
- Поставка сложных, дефицитных, либо снятых с производства позиций;
- Оперативные сроки поставки под заказ (от 5 рабочих дней);
- Экспресс доставка в любую точку России;
- Техническая поддержка проекта, помощь в подборе аналогов, поставка прототипов;
- Система менеджмента качества сертифицирована по Международному стандарту ISO 9001;
- Лицензия ФСБ на осуществление работ с использованием сведений, составляющих государственную тайну;
- Поставка специализированных компонентов (Xilinx, Altera, Analog Devices, Intersil, Interpoint, Microsemi, Aeroflex, Peregrine, Syfer, Eurofarad, Texas Instrument, Miteq, Cobham, E2V, MA-COM, Hittite, Mini-Circuits, General Dynamics и др.);

Помимо этого, одним из направлений компании «ЭлектроПласт» является направление «Источники питания». Мы предлагаем Вам помощь Конструкторского отдела:

- Подбор оптимального решения, техническое обоснование при выборе компонента;
- Подбор аналогов;
- Консультации по применению компонента;
- Поставка образцов и прототипов;
- Техническая поддержка проекта;
- Защита от снятия компонента с производства.



Как с нами связаться

Телефон: 8 (812) 309 58 32 (многоканальный)

Факс: 8 (812) 320-02-42

Электронная почта: org@eplast1.ru

Адрес: 198099, г. Санкт-Петербург, ул. Калинина, дом 2, корпус 4, литера А.