

## GENERAL DESCRIPTION

The XRP2997 is a Double Data Rate (DDR) termination voltage regulator supporting all power requirements of DDR I, II, III and IV memories and is capable of sinking or sourcing 2A continuously.

Tightly regulating its output voltage within  $\pm 20\text{mV}$ , the XRP2997 converts input voltages as low as 1.1V while the output voltage is adjustable through an external resistor divider or by forcing the  $V_{\text{REF}}$  pin voltage. It maintains a fast line and load transient response and only requires an output capacitance of  $22\mu\text{F}$  to operate. An enable function via an external MOSFET and a soft start feature allow for a controlled implementation of power-up sequencing.

Built-in source/sink overcurrent, over-temperature and under-voltage lockout protections insure safe operation under abnormal operating conditions.

The XRP2997 meets JEDEC SSTL-2, SSTL-18, HSTL, SCSI-1 and SCSI-3 specifications for DDR SDRAM memories.

The XRP2997 is offered in a RoHS compliant, "green"/halogen free 8-pin Exposed Pad SOIC package.

## APPLICATIONS

- **DDR I/II/III/IV Memory Termination**
- **Active Termination Buses**
- **Audio-Video Equipments**
- **Video-Graphics Cards**

## FEATURES

- **DDR1, DDR2, DDR3 and DDR4 Support**
  - 0.75V<sub>TT</sub> Generation
  - $\pm 20\text{mV}$  Output Voltage Offset
- **2 Amps Continuous Current Sourcing & Sinking**
  - 1.1V to 5.5V Wide Input Voltage Range
- **Adjustable Output Voltage**
- **Suspend to RAM(STR), Enable & Soft Start Functions**
- **Stable with 22 $\mu\text{F}$  Ceramic Capacitor**
- **UVLO, Over Temperature and Over Current Protections**
- **Minimal External Components**
- **Pin/Function Compatible with SP2996B**
- **RoHS Compliant "Green"/Halogen Free 8-Pin SOIC Package**

## TYPICAL APPLICATION DIAGRAM

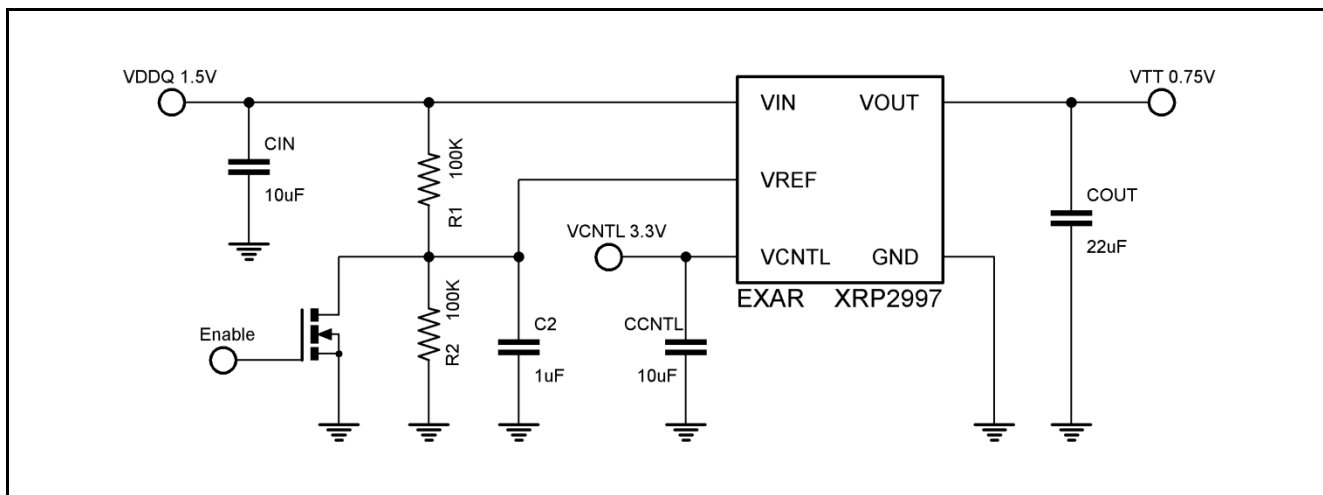

Fig. 1: XRP2997 DDR III V<sub>TT</sub> Application Diagram

### ABSOLUTE MAXIMUM RATINGS

These are stress ratings only and functional operation of the device at these ratings or any other above those indicated in the operation sections of the specifications below is not implied. Exposure to absolute maximum rating conditions for extended periods of time may affect reliability.

$V_{IN}$ ,  $V_{REF}$ ,  $V_{CNTL}$  ..... -0.3V to 6.0V  
 Junction Temperature Range..... -40°C to +150°C  
 Storage Temperature..... -65°C to +150°C  
 Lead Temperature (Soldering, 10 sec) ..... 260°C

### OPERATING RATINGS

Operating Temperature Range..... -40°C to +85°C  
 Thermal Resistance  $\theta_{JA}$  ..... 60°C/W  
 Thermal Resistance  $\theta_{JC}$  ..... 16°C/W

### ELECTRICAL SPECIFICATIONS

Specifications are for an Operating Ambient Temperature of  $T_A = 25^\circ\text{C}$  only; limits applying over the full Operating Junction Temperature range are denoted by a “\*”. Minimum and Maximum limits are guaranteed through test, design, or statistical correlation. Typical values represent the most likely parametric norm at  $T_A = 25^\circ\text{C}$ , and are provided for reference purposes only. Unless otherwise indicated,  $V_{IN} = 1.8\text{V}/1.5\text{V}$ ,  $V_{CNTL} = 3.3\text{V}$ ,  $V_{REF} = 0.5 \times V_{IN}$ ,  $C_{OUT} = 22\mu\text{F}$  (ceramic),  $T_A = 25^\circ\text{C}$ .

Parameter	Min.	Typ.	Max.	Units	Conditions
$V_{IN}$ , Input Voltage Range	1.1	1.8/1.5	5.5	V	Keep $V_{CNTL} \geq V_{IN}$ during power on and power off sequences (note 4)
$V_{CNTL}$ , Input Voltage Range	2.375	3.3	5.5	V	Keep $V_{CNTL} \geq V_{IN}$ during power on and power off sequences (note 4)
$V_{OUT}$ , Output Voltage	$V_{REF}$			V	$I_{OUT} = 0\text{mA}$
$V_{OS}$ , Output Voltage Offset	-20		+20	mV	$I_{OUT} = 0\text{mA}$ (note 1)
$\Delta V_{LOR}$ , Load Regulation	-20		+20	mV	$I_{OUT} = 0.1\text{mA}$ to +2A
	-20		+20	mV	$I_{OUT} = 0.1\text{mA}$ to -2A
$I_Q$ , Quiescent Current		2	90	$\mu\text{A}$	$V_{REF} < 0.2\text{V}$ , $V_{OUT} = \text{OFF}$
$I_{CNTL}$ , Operating Current of $V_{CNTL}$		1	2.5	mA	$I_{OUT} = 0\text{mA}$
$I_{REF}$ , Bias Current of $V_{REF}$	0		1	$\mu\text{A}$	$V_{REF} = 1.25\text{V}$
$I_{IL}$ , Current Limit	2.4	3		A	Source: $V_{OUT} = 0.33 \times V_{REF}$ Sink: $V_{OUT} = 0.95 \times V_{IN}$ (note 3)
$R_{DSCHG}$ , Output Discharge Resistance		18	25	$\Omega$	$V_{REF} = 0\text{V}$ , $V_{OUT} = 0.3\text{V}$
<b>Thermal Protection</b>					
$T_{SD}$ , Thermal Shutdown Temperature		160		$^\circ\text{C}$	$3.3\text{V} \leq V_{CNTL} \leq 5\text{V}$ , guaranteed by design (note 4)
Thermal Shutdown Hysteresis		30		$^\circ\text{C}$	Guaranteed by design
<b>Shutdown Specifications</b>					
$V_{TRIGGER}$ , Shutdown Threshold	0.6			V	Output ON $V_{REF} = 0\text{V} \rightarrow 1.25\text{V}$
			0.2		Output OFF $V_{REF} = 1.25\text{V} \rightarrow 0\text{V}$

Note 1:  $V_{OS}$  offset is the voltage measurement defined as  $V_{OUT}$  subtracted from  $V_{REF}$ .

Note 2: Load regulation is measured at constant junction temperature, using pulse testing with a short ON time.

Note 3: Current limit is measured by applying a short duration current pulse.

Note 4: In order to safely operate yo2ur system,  $V_{CNTL}$  must be  $> V_{IN}$ .

**BLOCK DIAGRAM**

Fig. 2: XRP2997 Block Diagram

**PIN ASSIGNMENT**

Fig. 3: XRP2997 Pin Assignment

**PIN DESCRIPTION**

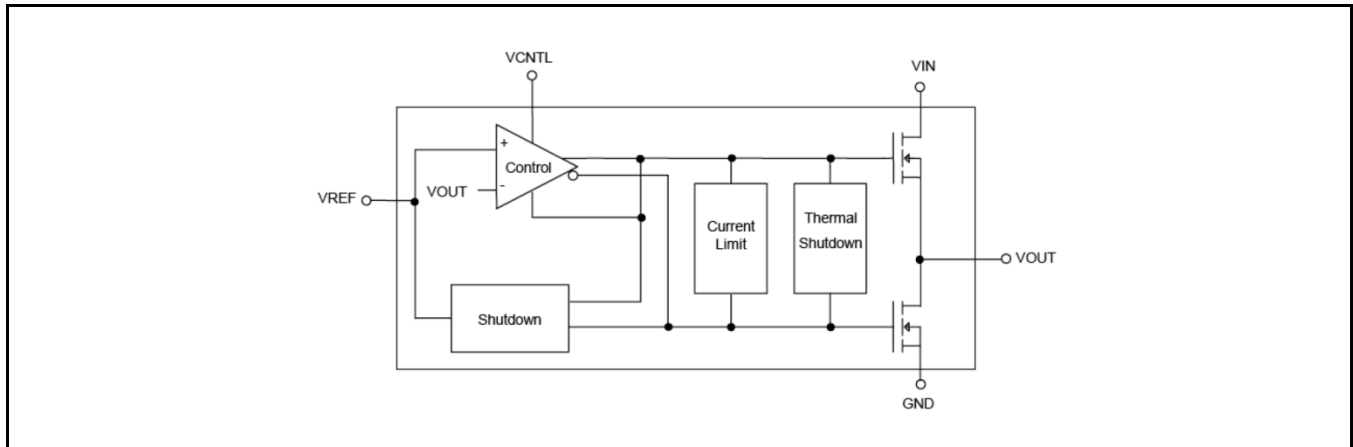
Name	Pin Number	Description
$V_{IN}$	1	Power Input Voltage
GND	2	Ground Signal
	Exposed Pad	
$V_{REF}$	3	Reference Input Voltage. This input can also be used as an enable signal; pulling this pin low shuts down the XRP2997. Refer to typical application circuit.
$V_{OUT}$	4	Output Voltage
NC	5, 7, 8	NC
$V_{CNTRL}$	6	Voltage for the driver circuit and all analog blocks

**ORDERING INFORMATION<sup>(1)</sup>**

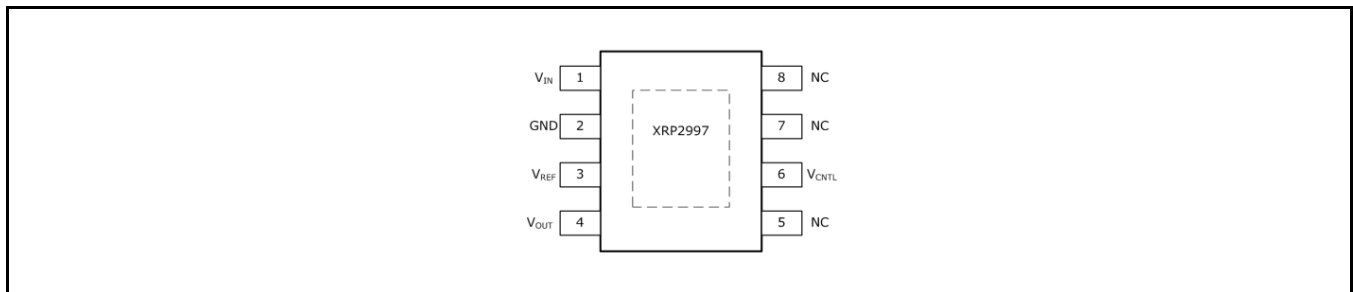
Part Number	Operating Temperature Range	Lead-Free	Package	Packing Method
XRP2997IDBTR-F	$-40^{\circ}\text{C} \leq T_A \leq +85^{\circ}\text{C}$	Yes <sup>(2)</sup>	Exposed pad HSOIC-8 Option 1	Tape & Reel

NOTE:

1. Refer to [www.exar.com/XRP2997](http://www.exar.com/XRP2997) for most up-to-date Ordering Information
2. Visit [www.exar.com](http://www.exar.com) for additional information on Environmental Rating.

**TYPICAL PERFORMANCE CHARACTERISTICS**

All data taken at  $V_{IN} = 1.8V/1.5V$ ,  $V_{CNTL} = 3.3V$ ,  $V_{REF} = 0.5 \times V_{IN}$ ,  $C_{OUT} = 22\mu F$  (ceramic),  $T_A = 25^\circ C$ , unless otherwise specified - Schematic and BOM from Application Information section of this datasheet.

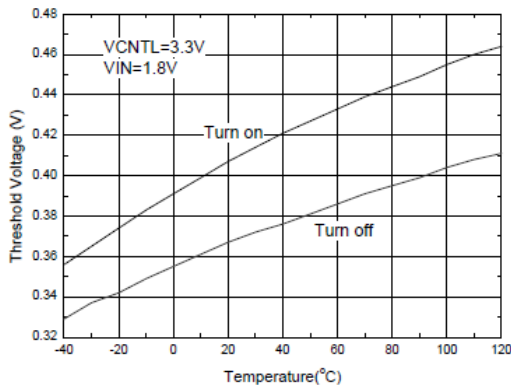

Fig. 4: Turn on and turn off vs. Temperature

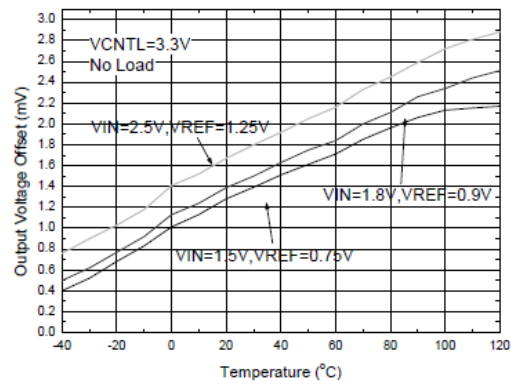

Fig. 5: Output Voltage vs. Temperature

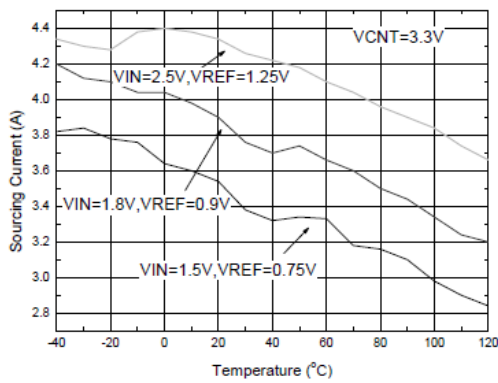

Fig. 6: Current limit (sourcing) vs. Temperature

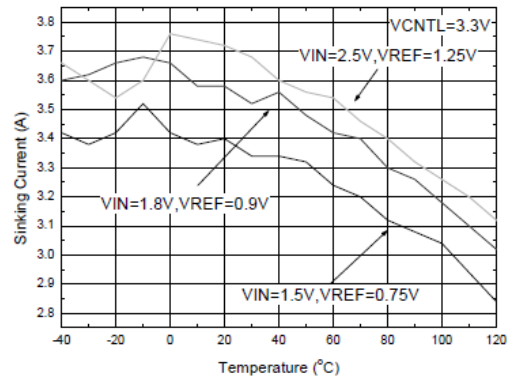

Fig. 7: Current limit (sinking) vs. Temperature

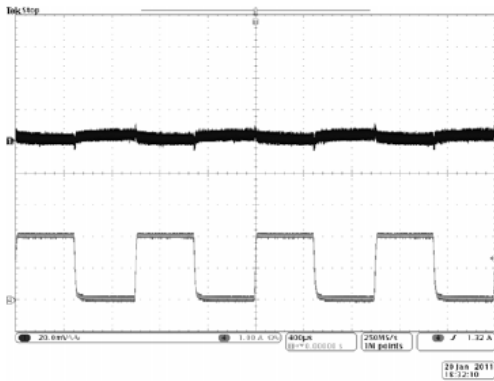

Fig. 8:  $V_{IN}=1.5V$ ,  $V_{REF}=0.75V$  source response

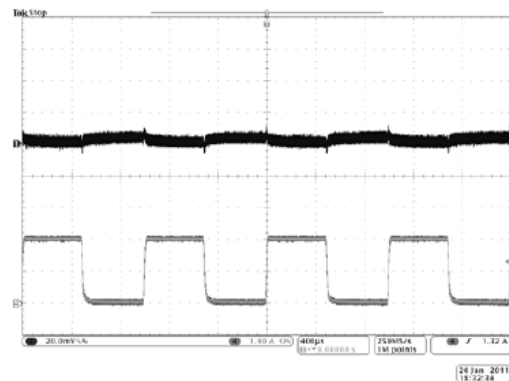

Fig. 9:  $V_{IN}=1.8V$ ,  $V_{REF}=0.9V$  source response

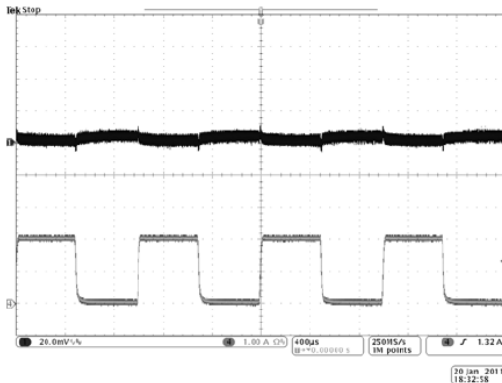

Fig. 10:  $V_{IN}=2.5V$ ,  $V_{REF}=1.25V$  source response

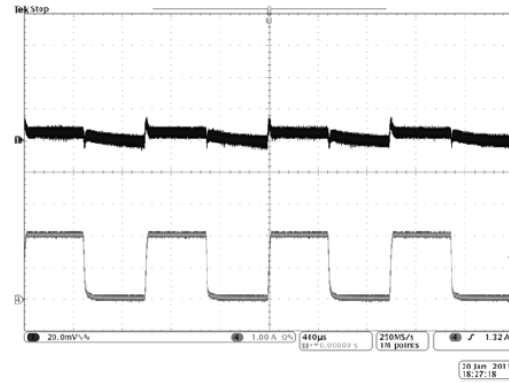

Fig. 11:  $V_{IN}=1.5V$ ,  $V_{REF}=0.75V$  sink response

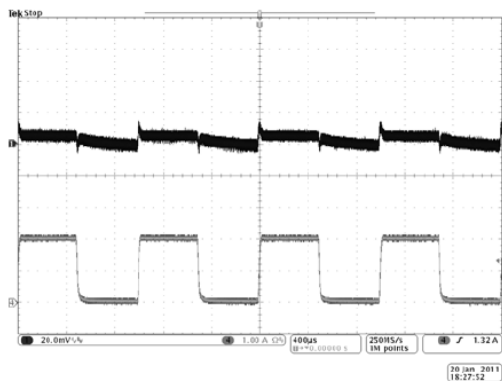

Fig. 9:  $V_{IN}=1.8V$ ,  $V_{REF}=0.9V$  sink response

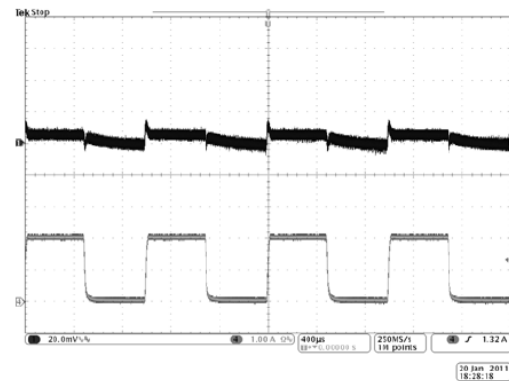

Fig. 10:  $V_{IN}=2.5V$ ,  $V_{REF}=1.25V$  sink response

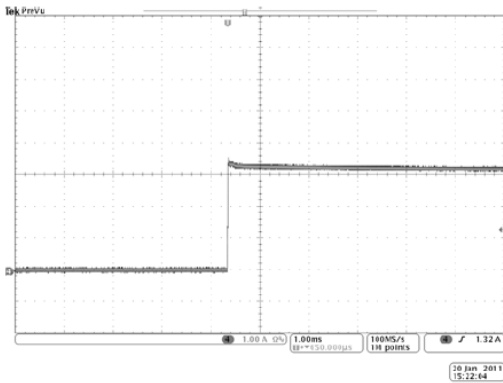

Fig. 14:  $V_{IN}=1.5V$ ,  $V_{REF}=0.75V$  source short circuit

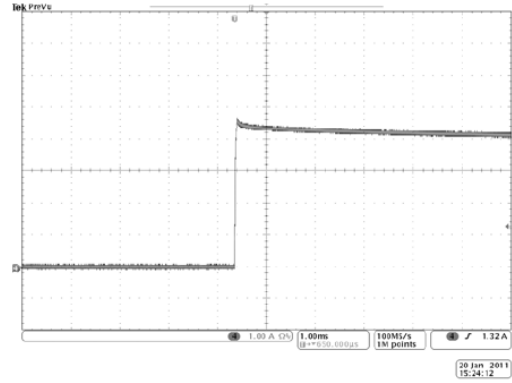

Fig. 15:  $V_{IN}=1.8V$ ,  $V_{REF}=0.9V$  source short circuit

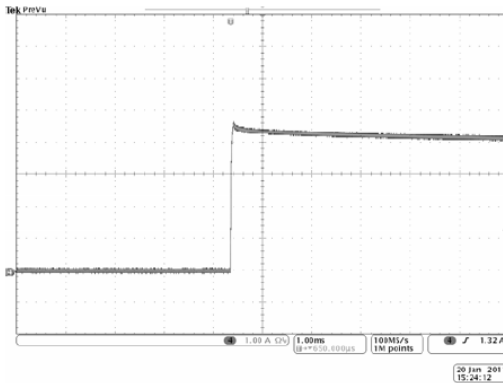

Fig. 11:  $V_{IN}=2.5V$ ,  $V_{REF}=1.25V$  source short circuit

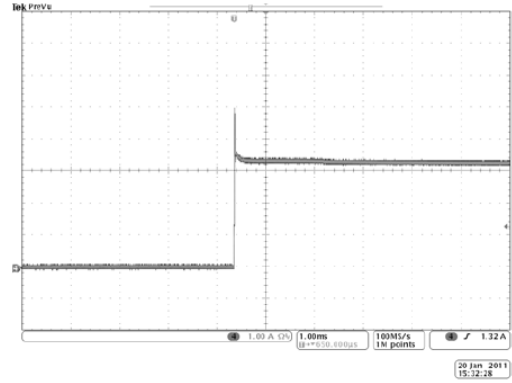

Fig. 12:  $V_{IN}=1.5V$ ,  $V_{REF}=0.75V$  sink short circuit

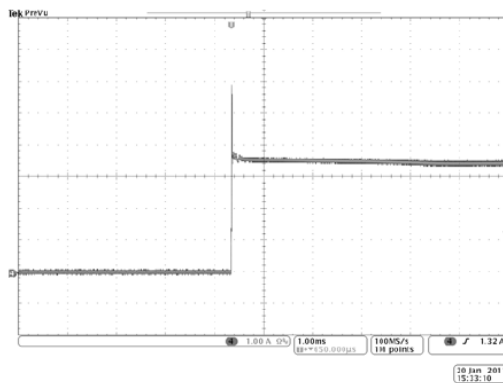

Fig. 13:  $V_{IN}=1.8V$ ,  $V_{REF}=0.9V$  sink short circuit

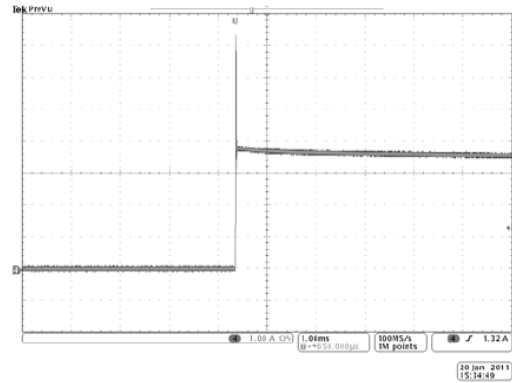

Fig. 14:  $V_{IN}=2.5V$ ,  $V_{REF}=1.25V$  sink short circuit

**APPLICATION INFORMATION****INPUT CAPACITOR C<sub>IN</sub>**

Select the input capacitor C<sub>IN</sub> for voltage rating, RMS current rating and capacitance. The voltage rating should be at least 50% higher than the regulator's maximum input voltage. The value of this capacitor, its charge, should be selected in order to be able to supply enough current to the XRP2997 in the event of a transient increase of source current required. A minimum value of 10 $\mu$ F is advised while a

recommended value of 47 $\mu$ F is recommended for optimum transient response performance.

**LAYOUT CONSIDERATIONS**

The XRP2997 is offered in the 8-pin exposed-pad SOIC package in order to facilitate power dissipation (heat dissipation). Power dissipation can be maximized by soldering the exposed pad to a large land area on top layer of PCB and by using vias to connect the exposed pad to an interlayer(s) or bottom layer. All capacitors should be placed as close as possible to the respective pins.

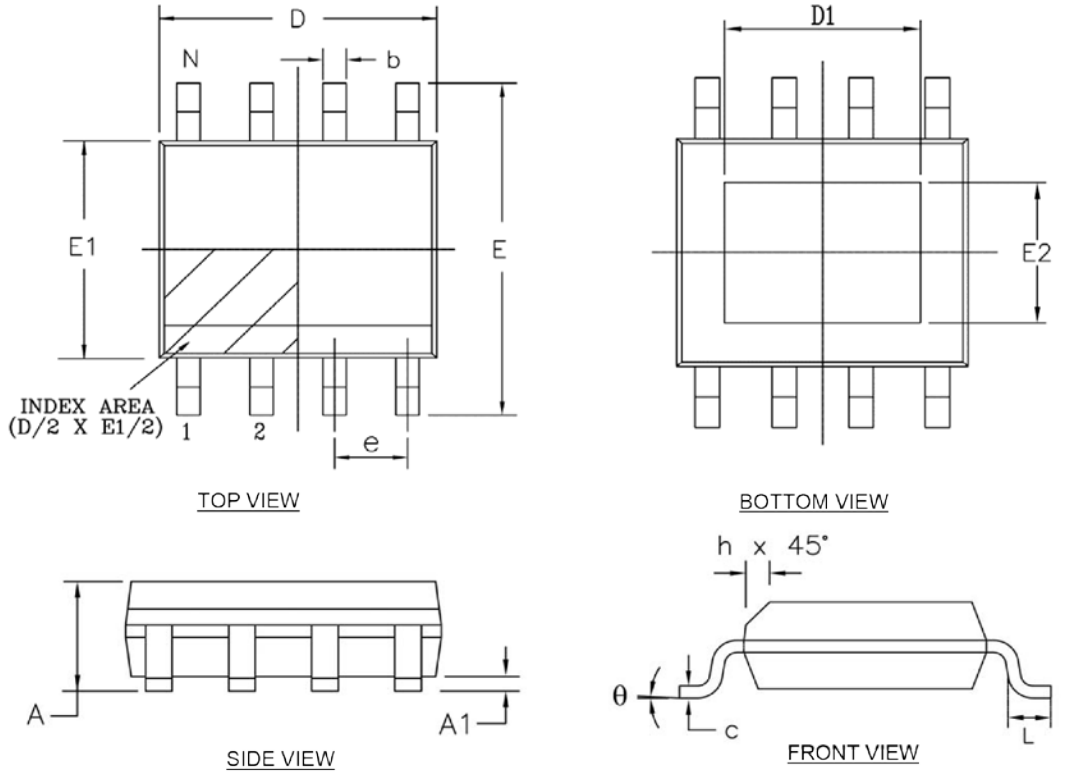
**PACKAGE SPECIFICATION**
**8-PIN HSOIC (EXPOSED PAD) OPTION 1**

8 Pin HSOICN JEDEC MS-012 Variation BA			
SYMBOLS	DIMENSIONS IN MM		
	MIN	NOM	MAX
A	1.35		1.75
A1	0.00		0.15
b	0.31		0.51
c	0.17		0.25
D	4.80		5.00
D1	1.50		3.50
E	5.80		6.20
E1	3.80		4.00
E2	1.00		2.55
e	1.27 BSC		
h	0.25		0.50
L	0.40		1.27
$\theta$	$0^\circ$		$8^\circ$
N	8		

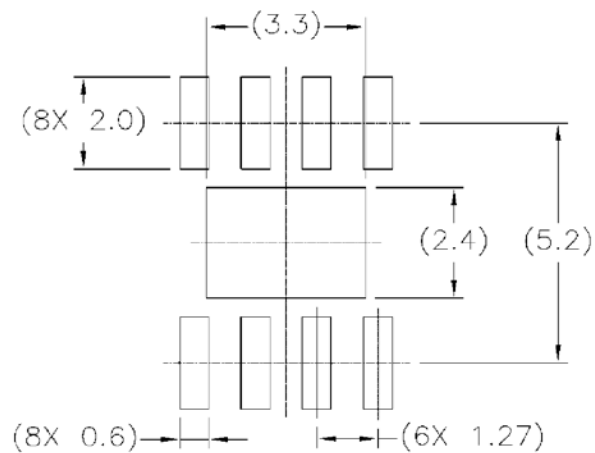
**TERMINAL DETAILS**

NOTE : ALL DIMENSIONS ARE IN MILLIMETERS, ANGLES ARE IN DEGREE

Drawing No. : POD\_0000125

Revision: A



**REVISION HISTORY**

Revision	Date	Description
1.0.0	07/22/2011	Initial release of datasheet
1.1.0	01/09/2012	Corrected part number in ordering information
1.1.1	03/29/2012	Corrected turn on threshold from 0.8V to 0.6V. Typographical error.
1.2.0	10/29/2012	Reformat of datasheet Updated typical application schematics (figure 1) Addition of CIN selection under Application Information section
1.2.1	8/17/2017	Added DDR IV. Updated to MaxLinear logo. Updated format, ordering information and package drawing.

**FOR FURTHER ASSISTANCE**

Email:

<mailto:customersupport@exar.com><mailto:powertechsupport@exar.com>**Corporate Headquarters:**

5966 La Place Court

Suite 100

Carlsbad, CA 92008

Tel.: +1 (760) 692 0711

Fax: +1 (760)444-8598

[www.maxlinear.com](http://www.maxlinear.com)**High Performance Analog:**

48720 Kato Road

Fremont, CA 94538 – USA

Tel.: +1 (510) 668-7000

Fax: +1 (510) 668-7030

[www.exar.com](http://www.exar.com)

The content of this document is furnished for informational use only, is subject to change without notice, and should not be construed as a commitment by MaxLinear, Inc.. MaxLinear, Inc. assumes no responsibility or liability for any errors or inaccuracies that may appear in the informational content contained in this guide. Complying with all applicable copyright laws is the responsibility of the user. Without limiting the rights under copyright, no part of this document may be reproduced into, stored in, or introduced into a retrieval system, or transmitted in any form or by any means (electronic, mechanical, photocopying, recording, or otherwise), or for any purpose, without the express written permission of MaxLinear, Inc.

MaxLinear, Inc. does not recommend the use of any of its products in life support applications where the failure or malfunction of the product can reasonably be expected to cause failure of the life support system or to significantly affect its safety or effectiveness. Products are not authorized for use in such applications unless MaxLinear, Inc. receives, in writing, assurances to its satisfaction that: (a) the risk of injury or damage has been minimized; (b) the user assumes all such risks; (c) potential liability of MaxLinear, Inc. is adequately protected under the circumstances.

MaxLinear, Inc. may have patents, patent applications, trademarks, copyrights, or other intellectual property rights covering subject matter in this document. Except as expressly provided in any written license agreement from MaxLinear, Inc., the furnishing of this document does not give you any license to these patents, trademarks, copyrights, or other intellectual property.

Company and product names may be registered trademarks or trademarks of the respective owners with which they are associated.

© 2012 - 2017 MaxLinear, Inc. All rights reserved



Компания «ЭлектроПласт» предлагает заключение долгосрочных отношений при поставках импортных электронных компонентов на взаимовыгодных условиях!

Наши преимущества:

- Оперативные поставки широкого спектра электронных компонентов отечественного и импортного производства напрямую от производителей и с крупнейших мировых складов;
- Поставка более 17-ти миллионов наименований электронных компонентов;
- Поставка сложных, дефицитных, либо снятых с производства позиций;
- Оперативные сроки поставки под заказ (от 5 рабочих дней);
- Экспресс доставка в любую точку России;
- Техническая поддержка проекта, помощь в подборе аналогов, поставка прототипов;
- Система менеджмента качества сертифицирована по Международному стандарту ISO 9001;
- Лицензия ФСБ на осуществление работ с использованием сведений, составляющих государственную тайну;
- Поставка специализированных компонентов (Xilinx, Altera, Analog Devices, Intersil, Interpoint, Microsemi, Aeroflex, Peregrine, Syfer, Eurofarad, Texas Instrument, Miteq, Cobham, E2V, MA-COM, Hittite, Mini-Circuits, General Dynamics и др.);

Помимо этого, одним из направлений компании «ЭлектроПласт» является направление «Источники питания». Мы предлагаем Вам помощь Конструкторского отдела:

- Подбор оптимального решения, техническое обоснование при выборе компонента;
- Подбор аналогов;
- Консультации по применению компонента;
- Поставка образцов и прототипов;
- Техническая поддержка проекта;
- Защита от снятия компонента с производства.



#### Как с нами связаться

**Телефон:** 8 (812) 309 58 32 (многоканальный)

**Факс:** 8 (812) 320-02-42

**Электронная почта:** [org@eplast1.ru](mailto:org@eplast1.ru)

**Адрес:** 198099, г. Санкт-Петербург, ул. Калинина, дом 2, корпус 4, литера А.