

Automotive integrated H-bridge

Datasheet - production data



Description

The device is an automotive integrated H-bridge intended for a wide range of automotive applications driving DC motors. The device incorporates a dual channel and two single channel MOSFETs. The device is designed using STMicroelectronics® well known and proven proprietary VIPower® M0-S9 technology that allows to integrate in a package four different channels in H-bridge topology.

This package, specifically designed for the harsh automotive environment offers improved thermal performance thanks to exposed die pads. Moreover, its fully symmetrical mechanical design allows superior manufacturability at board level.

Features

Type	R _{DS(on)}	I _{out}	V _{CCmax}
VNH9013Y	13 mΩ typ (per leg)	40 ⁽¹⁾	80 V ⁽²⁾

1. Max current to be set according to the wires capability
2. Per leg: sum of the two BV_{dss} (HSD + LSD); V_{CC} > 40 V whole bridge must be switched off;

- AEC-Q100 qualified 
- Maximum V_{CC} voltage: 80 V
- 10 V compatible inputs
- R_{DS(on)} per leg: 13 mΩ typical
- Embedded thermal sensor: -8.1 mV/°K
- Very low stray inductance in power line

Table 1. Device summary

Package	Order codes	
	Tube	Tape and reel
PowerSSO-36 TP	VNH9013Y	VNH9013YTR

Contents

- 1 Block diagram and pin description 5**

- 2 Electrical specifications 7**
 - 2.1 Absolute maximum rating 7
 - 2.2 Electrical characteristics 8

- 3 Package and PCB thermal data 12**
 - 3.1 PowerSSO-36 thermal data 12
 - 3.1.1 Thermal calculation in clockwise and anti-clockwise operation in steady-state mode 13
 - 3.1.2 Thermal resistance definitions (values according to the PCB heatsink area) 14
 - 3.1.3 Thermal calculation in transient mode 14
 - 3.1.4 Single pulse thermal impedance definitions (values according to the PCB heatsink area) 14

- 4 Package information 18**
 - 4.1 PowerSSO-36 TP package information 18
 - 4.2 PowerSSO-36 TP packing information 20
 - 4.3 PowerSSO-36 marking information 21

- 5 Revision history 22**

List of tables

Table 1.	Device summary	1
Table 2.	Pin definitions and functions	6
Table 3.	Absolute maximum rating	7
Table 4.	Power off.	8
Table 5.	Power on.	8
Table 6.	Dynamic	8
Table 7.	Gate resistance.	9
Table 8.	Source drain diode	9
Table 9.	Switching on HSD.	9
Table 10.	Switching on LSD	9
Table 11.	Switching off HSD.	10
Table 12.	Switching off LSD	10
Table 13.	Thermal sensor	10
Table 14.	Thermal calculation in clockwise and anti-clockwise operation in steady-state mode	13
Table 15.	Thermal parameters	16
Table 16.	PowerSSO-36 TP mechanical data	19
Table 17.	Document revision history	22

List of figures

Figure 1.	Block diagram	5
Figure 2.	Configuration diagram	5
Figure 3.	Single pulse maximum current	7
Figure 4.	Gate charge test circuit	10
Figure 5.	Test circuit for inductive load switching and diode recovery times	11
Figure 6.	Switching times test circuit for resistive load	11
Figure 7.	PowerSSO-36™ PC board	12
Figure 8.	Chipset configuration	13
Figure 9.	Auto and mutual $R_{thj-amb}$ vs PCB copper area in open box free air condition	13
Figure 10.	PowerSSO-36 HSD thermal impedance junction ambient single pulse	15
Figure 11.	PowerSSO-36 LSD thermal impedance junction ambient single pulse	15
Figure 12.	Thermal fitting model of an H-bridge in PowerSSO-36	16
Figure 13.	PowerSSO-36 TP package outline	18
Figure 14.	PowerSSO-36 TP tube shipment (no suffix)	20
Figure 15.	PowerSSO-36 TP tape and reel shipment (suffix "TR")	20
Figure 16.	PowerSSO-36 marking information	21

1 Block diagram and pin description

Figure 1. Block diagram

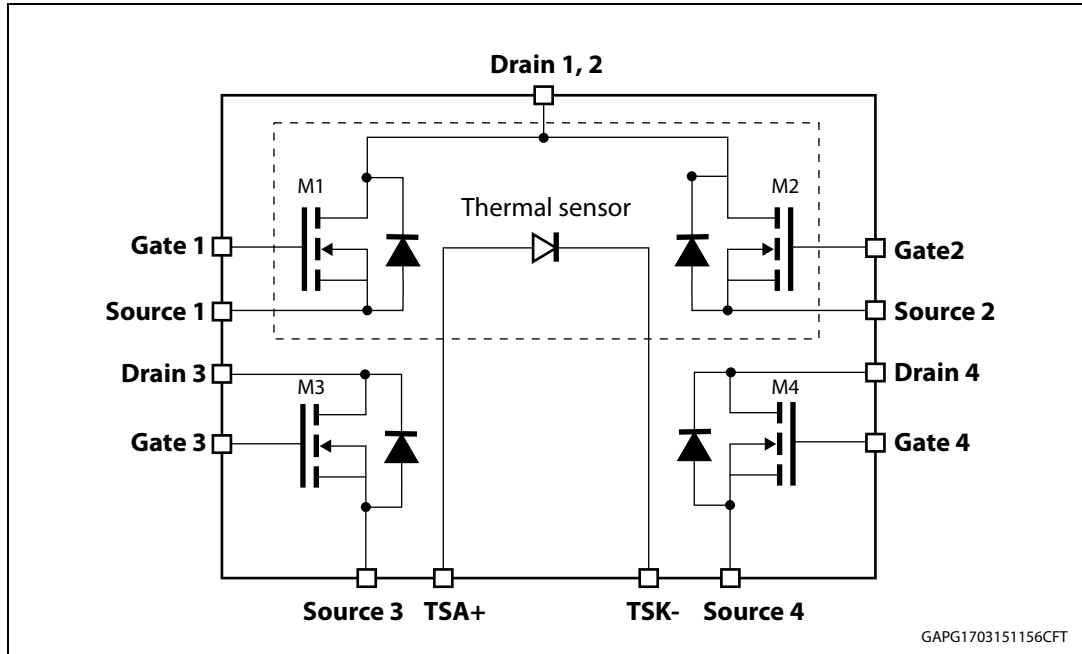

Figure 2. Configuration diagram

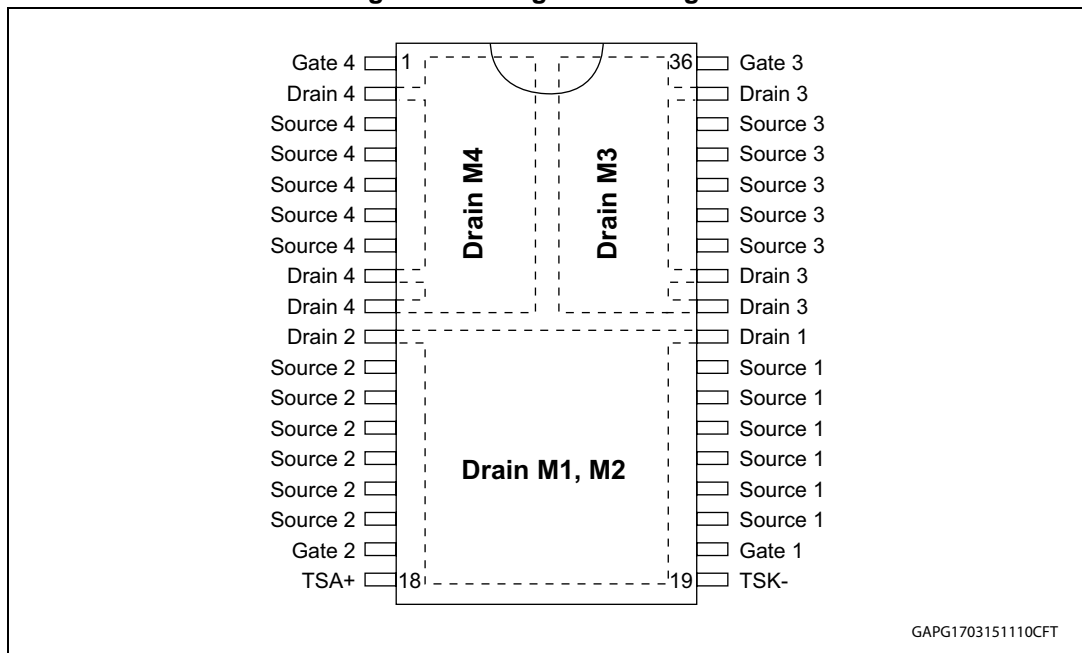

Table 2. Pin definitions and functions

Pin number	Symbol	Function
1	Gate 4	Gate of the LSD 4
2, 8, 9	Drain 4	Drain of the LSD 4
3, 4, 5, 6, 7	Source 4	Source of the LSD 4
10	Drain 2	Drain of the HSD 2
11, 12, 13, 14, 15, 16	Source 2	Source of the HSD 2
17	Gate 2	Gate of the HSD 2
18	TSA+	Thermal sensor anode
19	TSK-	Thermal sensor cathode
20	Gate 1	Gate of the HSD 1
21, 22, 23, 24, 25, 26	Source 1	Source of the HSD 1
27	Drain 1	Drain of the HSD 1
28, 29, 35	Drain 3	Drain of the LSD 3
30, 31, 32, 33, 34	Source 3	Source of the LSD 3
36	Gate 3	Gate of the LSD 3

2 Electrical specifications

2.1 Absolute maximum rating

Table 3. Absolute maximum rating

Symbol	Parameter	Value	Unit
V_{CC}	Supply voltage (whole bridge switched off)	80	V
I_{max}	Maximum output current (continuous) at $T_C = 150\text{ }^\circ\text{C}$	40	A
V_{GS_max}	Maximum gate source voltage	18	V
I_{Pulse_max}	Maximum Single Pulse output current	80 ⁽¹⁾	A
V_{ESD}	Electrostatic discharge HBM (JEDEC 22 A-114 F)		
	– DRAIN HS	4000	V
	– DRAIN LS	4000	
	– GATE HS	1000	
	– GATE LS	1000	
	– K+	750	
– K-	750		
T_j	Junction operating temperature	175	$^\circ\text{C}$
T_C	Case operating temperature	-40 to 150	$^\circ\text{C}$
T_{STG}	Storage temperature	-55 to 150	$^\circ\text{C}$
I_S	Diode continuous forward current	TBD	A

1. Pulse duration = 20 ms (see [Figure 3](#)).

Figure 3. Single pulse maximum current

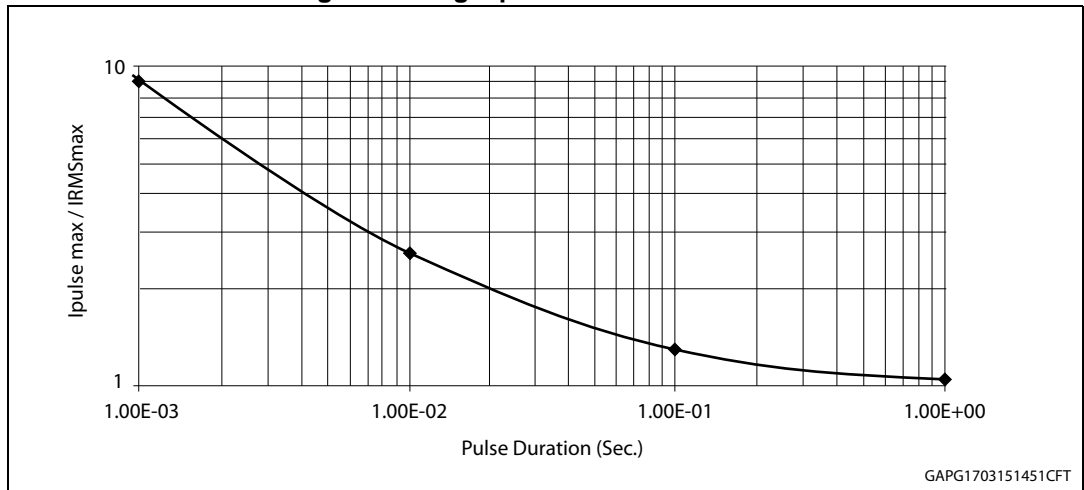

2.2 Electrical characteristics

Values specified in this section are for $V_{CC} = 7\text{ V}$ up to 28 V ; $-40\text{ °C} < T_j < 150\text{ °C}$, typical values are referred to $T_j = 25\text{ °C}$, unless otherwise specified.

Table 4. Power off

Symbol	Parameter	Test conditions	Min.	Typ.	Max.	Unit
$V_{(BR)DSS}$	Drain-source breakdown voltage for HSD and LSDs	$I_D = 10\text{ mA}$; $V_{GS} = 0\text{ V}$	40	—		V
I_{DSS}	Zero gate voltage drain current ($V_{GS} = 0\text{ V}$)	$V_{DS} = 28\text{ V}$; $-40\text{ °C} < T_j < 150\text{ °C}$		—	100	μA
		$V_{DS} = 28\text{ V}$; $T_j = 25\text{ °C}$		—	10	μA
I_{GSS}	Gate-source leakage current ($V_{DS} = 0\text{ V}$)	$V_{GS} = \pm 10\text{ V}$; $T_j = 25\text{ °C}$		—	± 100	nA

Table 5. Power on

Symbol	Parameter	Test conditions	Min.	Typ.	Max.	Unit
$V_{GS(th)}$	Gate threshold voltage	$V_{DS} = V_{GS}$; $I_D = 1\text{ mA}$; $T_j = 25\text{ °C}$	2		4	V
$dV_{GS(th)}/dT$ ⁽¹⁾	Gate threshold voltage temperature derating	$V_{DS} = V_{GS}$; $I_D = 1\text{ mA}$		-5.8		mV/°C
$R_{DS(on)_{HS}}$	Static drain-source on resistance	$V_{GS} = 10\text{ V}$; $I_D = 6\text{ A}$; $T_j = 25\text{ °C}$		6.0		m Ω
		$V_{GS} = 10\text{ V}$; $I_D = 6\text{ A}$; $T_j = 150\text{ °C}$			11.3	m Ω
$R_{DS(on)_{LS}}$	Static drain-source on resistance	$V_{GS} = 10\text{ V}$; $I_D = 6\text{ A}$; $T_j = 25\text{ °C}$		7.8		m Ω
		$V_{GS} = 10\text{ V}$; $I_D = 6\text{ A}$; $T_j = 150\text{ °C}$			15.3	m Ω

1. Guaranteed by design.

Table 6. Dynamic

Symbol	Parameter	Test condition	Min.	Typ.	Max.	Unit
$C_{iss_{HS}}$	Input capacitance	$V_{DS} = 25\text{ V}$; $f = 1\text{ MHz}$; $V_{GS} = 0\text{ V}$	—	2600	—	pF
$C_{oss_{HS}}$	Output capacitance		—	383	—	pF
$C_{rss_{HS}}$	Reverse transfer capacitance		—	165	—	pF
$C_{iss_{LS}}$	Input capacitance	$V_{DS} = 25\text{ V}$; $f = 1\text{ MHz}$; $V_{GS} = 0\text{ V}$	—	1750	—	pF
$C_{oss_{LS}}$	Output capacitance		—	257	—	pF
$C_{rss_{LS}}$	Reverse transfer capacitance		—	125	—	pF

Note: Parameters in [Table 6](#) are guaranteed by design.

Table 7. Gate resistance

Symbol	Parameter	Test condition	Min.	Typ.	Max.	Unit
R _{G_HS}	Gate resistance HS	V _{DD} = 15 V; f _{gate} = 1 MHz	—	7	—	Ω
R _{G_LS}	Gate resistance LS		—	4.7	—	Ω

Note: Parameters in [Table 7](#) are guaranteed by design.

Table 8. Source drain diode

Symbol	Parameter	Test conditions	Min.	Typ.	Max.	Unit
V _{SD} ⁽¹⁾	Forward on voltage	I _{SD} = 6 A; V _{GS} = 0 V; T _j = 25 °C	—	0.75	1.1	V
t _{rr} ⁽²⁾	Reverse recovery time	I _{SD} = 6 A; di/dt = 100 A/μs; V _{DD} = 15 V; T _j = 25 °C (see Figure 5)	—	40		ns
Q _{rr} ⁽³⁾	Reverse recovery charge		—	20		nC
I _{RRM} ⁽²⁾	Reverse recovery current		—	1		A

1. Pulse width limited by safe operating area.
2. Guaranteed by design.
3. Parameters guaranteed by design.

Table 9. Switching on HSD

Symbol	Parameter	Test conditions	Min.	Typ.	Max.	Unit
t _{d(on)}	Turn on delay time	V _{DD} = 15 V; I _D = 6 A; R _G = 4.7 Ω; V _{GS} = 10 V	—	44	—	ns
t _r	Rise time		—	85	—	ns
Q _g ⁽¹⁾	Total gate charge	V _{DD} = 15 V; I _D = 6 A; V _{GS} = 10 V (see Figure 4)	—	45	—	nC
Q _{gs} ⁽¹⁾	Gate-source charge		—	8	—	nC
Q _{gd} ⁽¹⁾	Gate-drain charge		—	8	—	nC

1. Parameters guaranteed by design.

Table 10. Switching on LSD

Symbol	Parameter	Test conditions	Min.	Typ.	Max.	Unit
t _{d(on)}	Turn on delay time	V _{DD} = 15 V; I _D = 6 A; R _G = 4.7 Ω; V _{GS} = 10 V	—	40	—	ns
t _r	Rise time		—	100	—	ns
Q _g ⁽¹⁾	Total gate charge	V _{DD} = 15 V; I _D = 6 A; V _{GS} = 10 V (see Figure 4)	—	40	—	nC
Q _{gs} ⁽¹⁾	Gate-source charge		—	4.9	—	nC
Q _{gd} ⁽¹⁾	Gate-drain charge		—	6.2	—	nC

1. Parameters guaranteed by design.

Table 11. Switching off HSD

Symbol	Parameter	Test conditions	Min.	Typ.	Max.	Unit
$t_{d(off)}$	Turn-off delay time	$V_{DD} = 15\text{ V}; I_D = 6\text{ A}; R_G = 4.7\ \Omega;$	—	114	—	ns
t_f	Fall time	$V_{GS} = 10\text{ V}$ (see Figure 6)	—	27	—	ns

Table 12. Switching off LSD

Symbol	Parameter	Test conditions	Min.	Typ.	Max.	Unit
$t_{d(off)}$	Turn-off delay time	$V_{DD} = 15\text{ V}; I_D = 6\text{ A}; R_G = 4.7\ \Omega;$	—	83	—	ns
t_f	Fall time	$V_{GS} = 10\text{ V}$ (see Figure 6)	—	25	—	ns

Table 13. Thermal sensor

Symbol	Parameter	Test conditions	Min.	Typ.	Max.	Unit
V_F	Chain diode forward voltage	$T_j = 25\text{ }^\circ\text{C}; I_F = 250\ \mu\text{A}$	680	720	760	mV
$S_F^{(1)}$	Chain temperature coefficient	$-40\text{ }^\circ\text{C} < T_j < 175\text{ }^\circ\text{C}; I_F = 250\ \mu\text{A}$		-2		mV/°K

1. Parameters guaranteed by design.

Figure 4. Gate charge test circuit

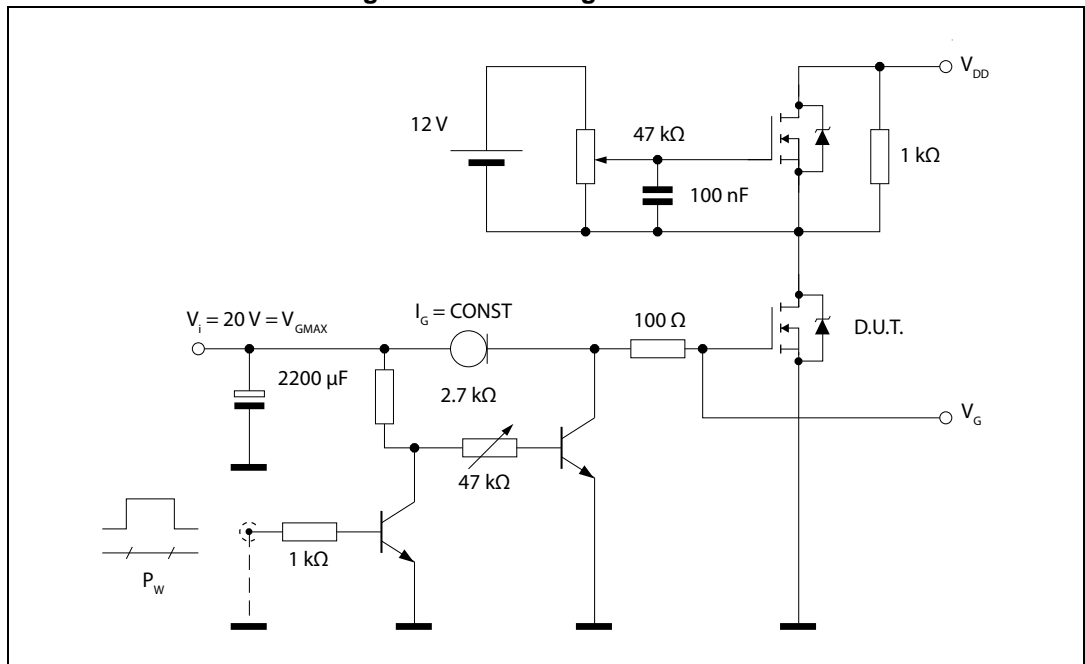

Figure 5. Test circuit for inductive load switching and diode recovery times

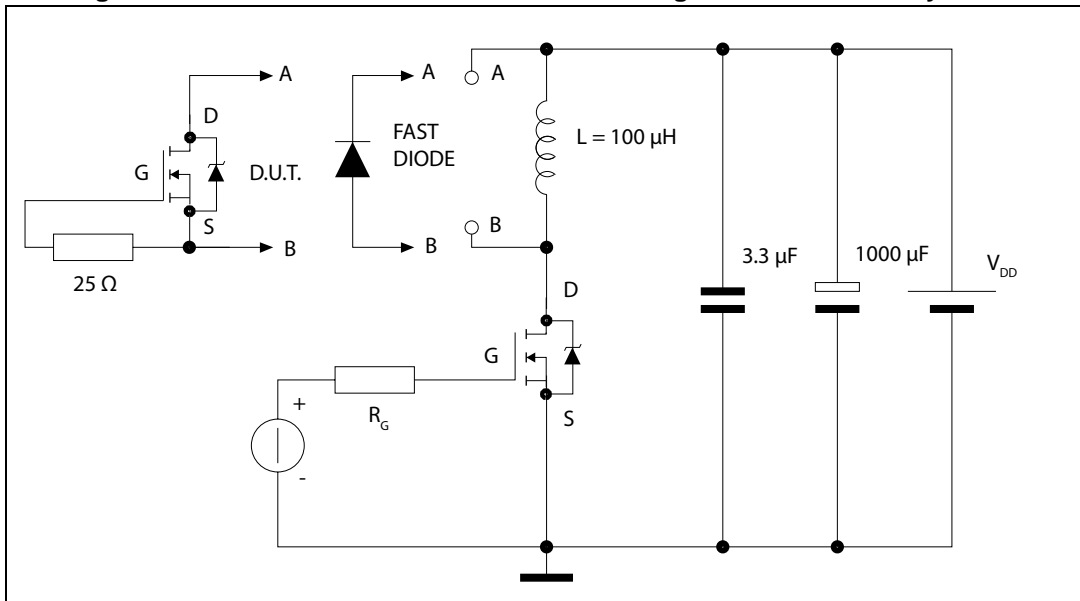
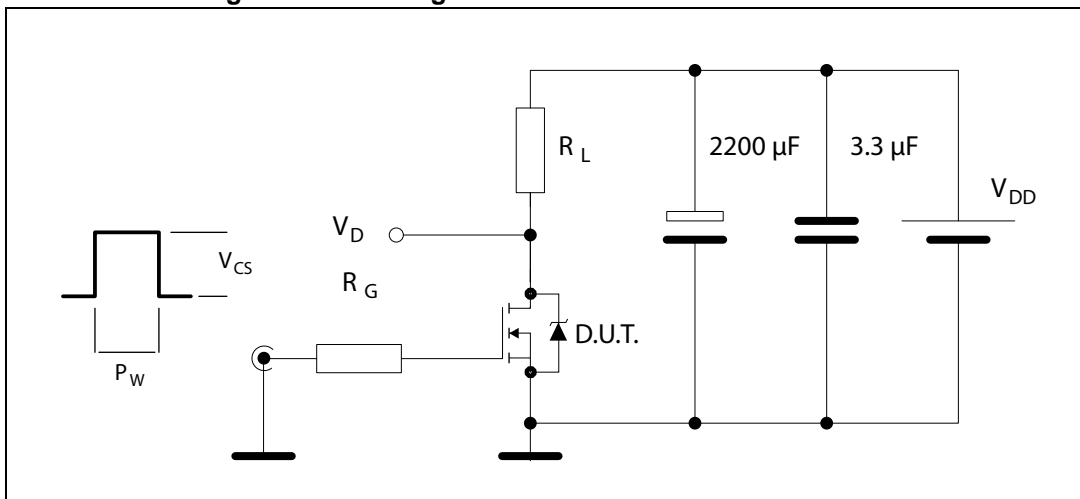

Figure 6. Switching times test circuit for resistive load



3 Package and PCB thermal data

3.1 PowerSSO-36 thermal data

Figure 7. PowerSSO-36™ PC board

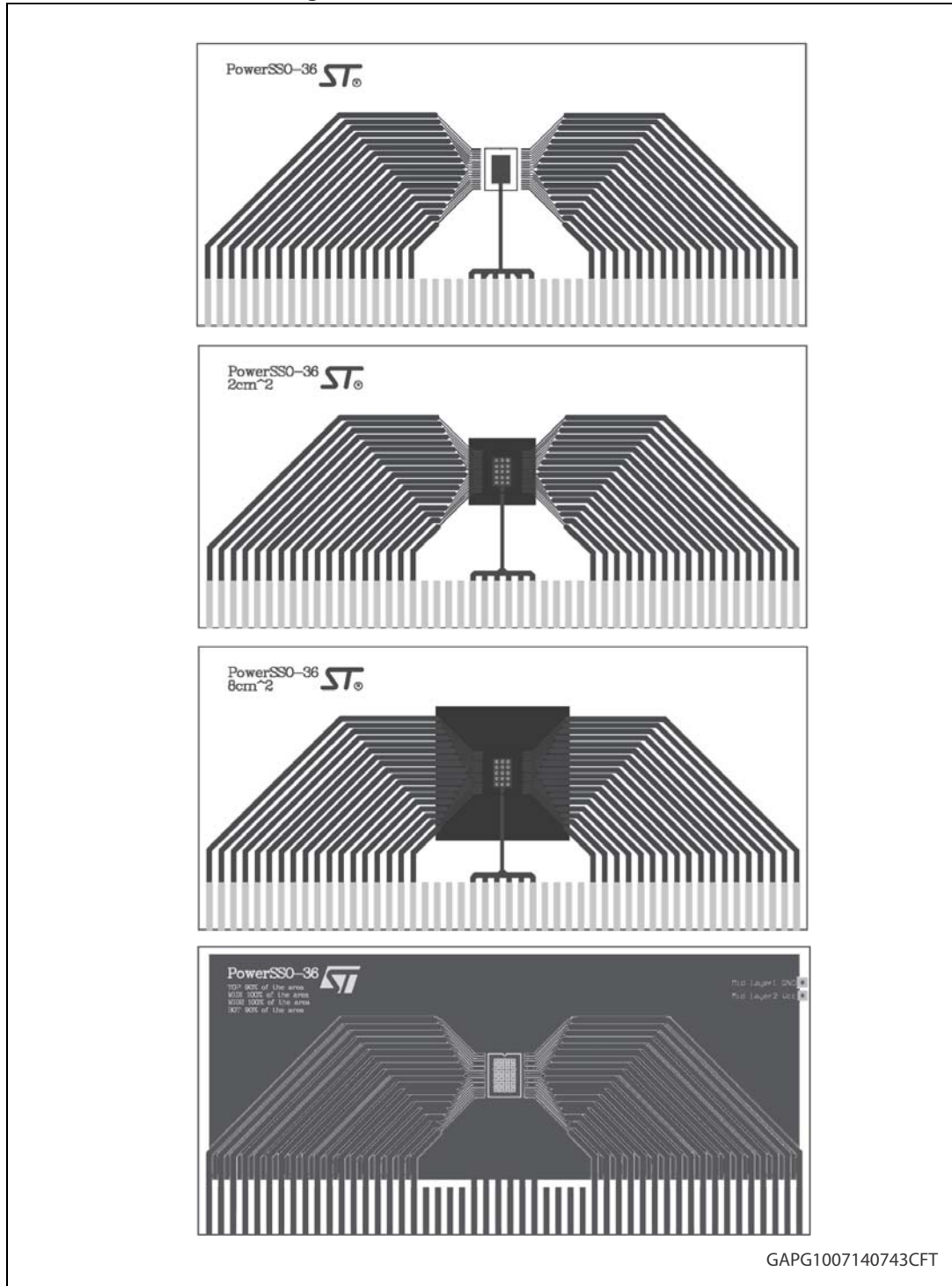

Figure 8. Chipset configuration

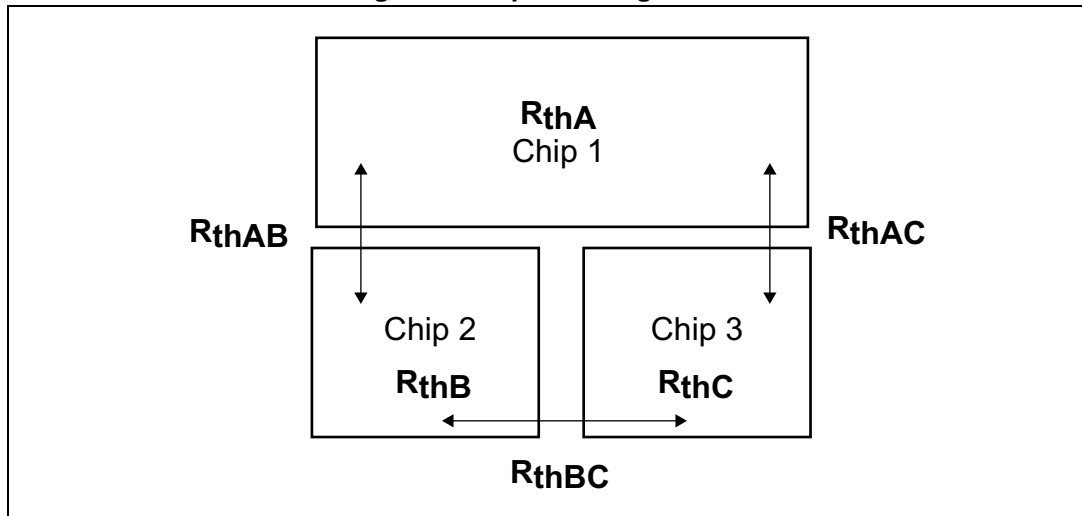
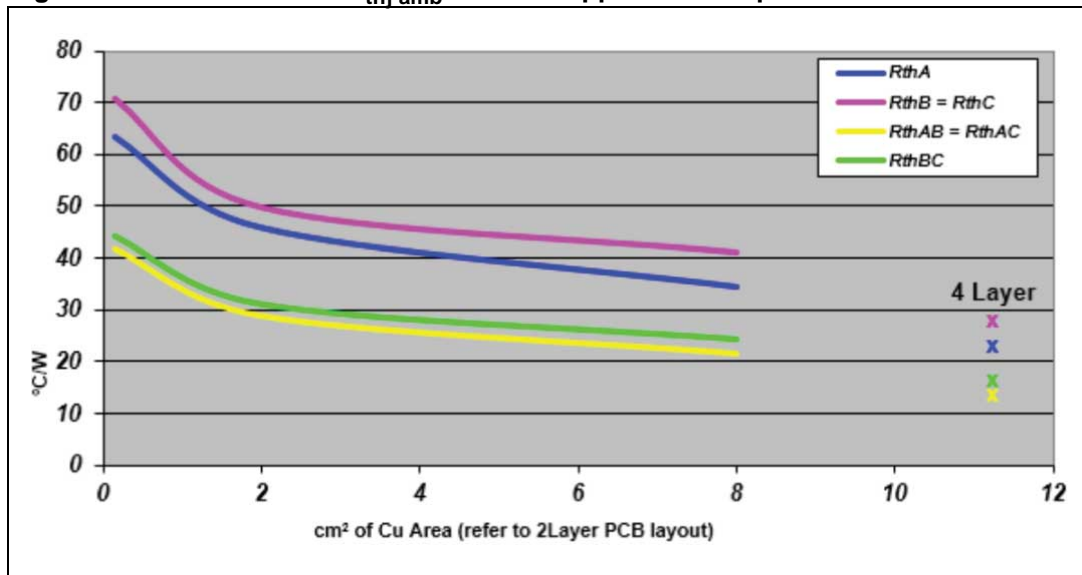

Figure 9. Auto and mutual $R_{thj-amb}$ vs PCB copper area in open box free air condition



3.1.1 Thermal calculation in clockwise and anti-clockwise operation in steady-state mode

Table 14. Thermal calculation in clockwise and anti-clockwise operation in steady-state mode

HS _A	HS _B	LS _A	LS _B	T _{jHSAB}	T _{jLSA}	T _{jLSB}
ON	OFF	OFF	ON	$\frac{P_{dHSA} \times R_{thHS} + P_{dLSB} \times R_{thHLS} + T_{amb}}{R_{thAB}}$	$\frac{P_{dHSA} \times R_{thHLS} + P_{dLSD} \times R_{thLSLS} + T_{amb}}{R_{thAC}}$	$\frac{P_{dHSA} \times R_{thHLS} + P_{dLSB} \times R_{thLS} + T_{amb}}{R_{thBC}}$
OFF	ON	ON	OFF	$\frac{P_{dHSB} \times R_{thHS} + P_{dLSA} \times R_{thHLS} + T_{amb}}{R_{thAB}}$	$\frac{P_{dHSB} \times R_{thHLS} + P_{dLSA} \times R_{thLS} + T_{amb}}{R_{thAC}}$	$\frac{P_{dHSB} \times R_{thHLS} + P_{dLSA} \times R_{thLSLS} + T_{amb}}{R_{thBC}}$

3.1.2 Thermal resistance definitions (values according to the PCB heatsink area)

- $R_{thHS} = R_{thHSA} = R_{thHSB}$ = high side chip thermal resistance junction to ambient (HSA or HSB in ON state)
- $R_{thLS} = R_{thLSA} = R_{thLSB}$ = low side chip thermal resistance junction to ambient
- $R_{thHSLS} = R_{thHSALSb} = R_{thHSBLsA}$ = mutual thermal resistance junction to ambient between high side and low side chips
- $R_{thLSLS} = R_{thLSALSb} = R_{thLSBLsA}$ = mutual thermal resistance junction to ambient between low side chips

3.1.3 Thermal calculation in transient mode^(a)

- $T_{jHSAB} = Z_{thHS} \times P_{dHSAB} + Z_{thHSLS} \times (P_{dLSA} + P_{dLSB}) + T_{amb}$
- $T_{jLSA} = Z_{thHSLS} \times P_{dHSAB} + Z_{thLS} \times P_{dLSA} + Z_{thLSLS} \times P_{dLSB} + T_{amb}$
- $T_{jLSB} = Z_{thHSLS} \times P_{dHSAB} + Z_{thLSLS} \times P_{dLSA} + Z_{thLS} \times P_{dLSB} + T_{amb}$

3.1.4 Single pulse thermal impedance definitions (values according to the PCB heatsink area)

- Z_{thHS} = high side chip thermal impedance junction to ambient
- $Z_{thLS} = Z_{thLSA} = Z_{thLSB}$ = low side chip thermal impedance junction to ambient
- $Z_{thHSLS} = Z_{thHSABLsA} = Z_{thHSABLsB}$ = mutual thermal impedance junction to ambient between high side and low side chips
- $Z_{thLSLS} = Z_{thLSALSb} = Z_{thLSBLsA}$ = mutual thermal impedance junction to ambient between low side chips

Equation 1: pulse calculation formula

$$Z_{TH\delta} = R_{TH} P \delta + Z_{THtp}(1 - \delta)$$

where $\delta = t_p/T$

a. Calculation is valid in any dynamic operating condition. P_d values set by user.

Figure 10. PowerSSO-36 HSD thermal impedance junction ambient single pulse

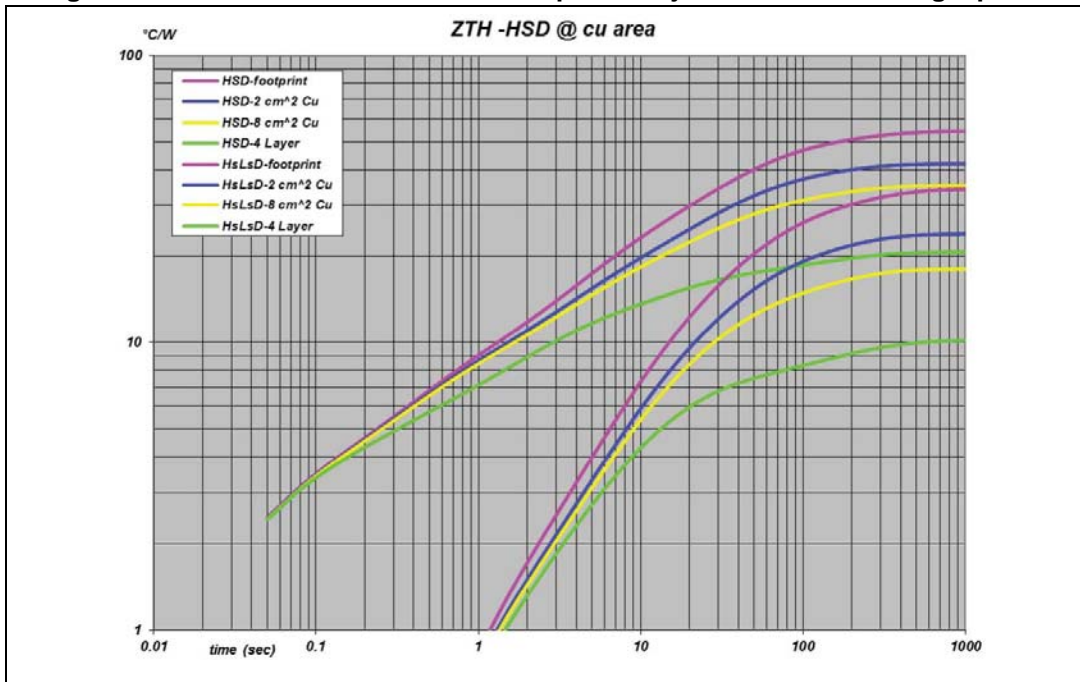

Figure 11. PowerSSO-36 LSD thermal impedance junction ambient single pulse

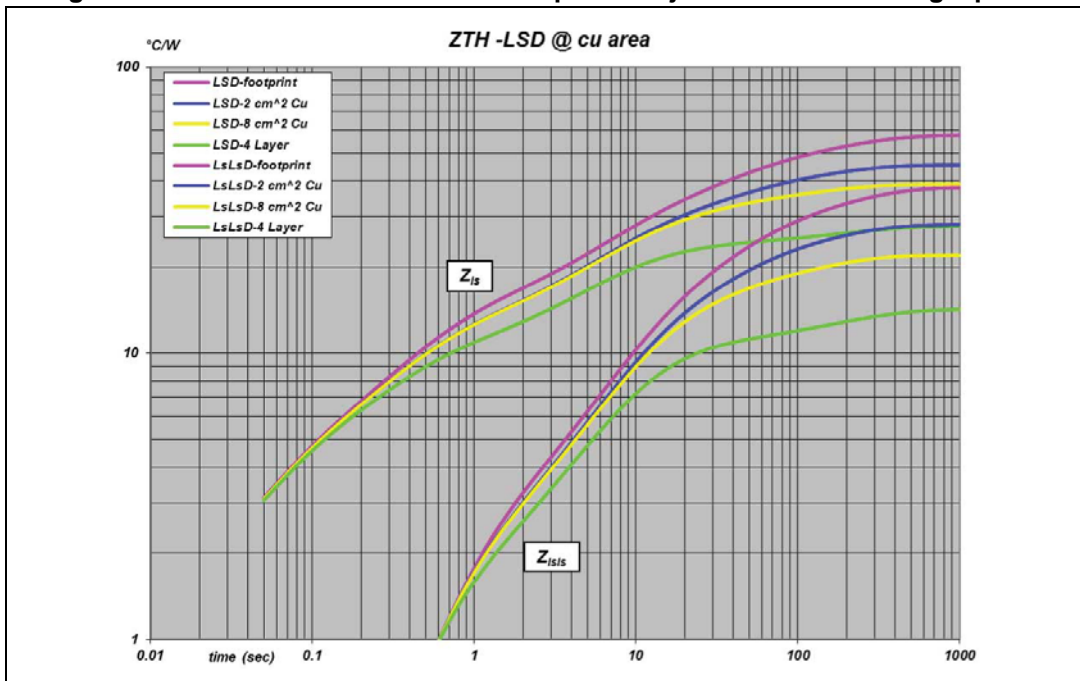

Figure 12. Thermal fitting model of an H-bridge in PowerSSO-36

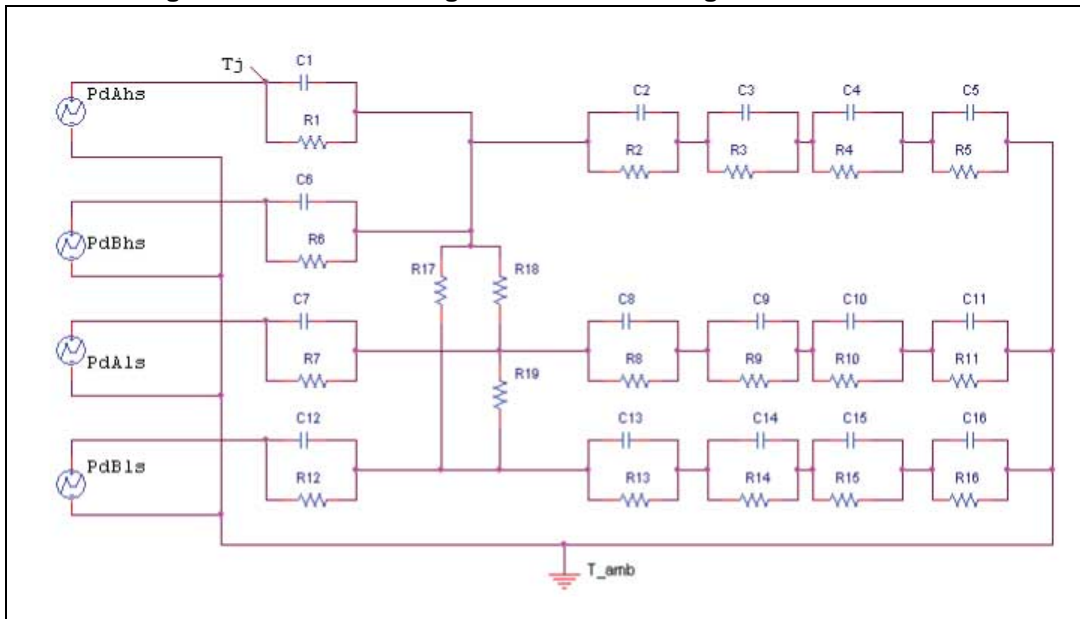

Table 15. Thermal parameters⁽¹⁾

Area/island (cm ²)	FP	2	8	4L
R1 (°C/W)	2.4			
R2 (°C/W)	4	4	4	2
R3 (°C/W)	14	10	10	8
R4 (°C/W)	50	32	22	9
R5 (°C/W)	34	26	21	8
R6 (°C/W)	2.4			
R7 (°C/W)	2.8			
R8 (°C/W)	12	10	10	8
R9 (°C/W)	37	35	35	30
R10 (°C/W)	41	30	20	10
R11 (°C/W)	50	31	20	15
R12 (°C/W)	2.8			
R13 (°C/W)	12	10	10	8
R14 (°C/W)	37	35	35	30
R15 (°C/W)	41	30	20	10
R16 (°C/W)	50	31	20	15
R17 (°C/W)	73	70	70	50
R18 (°C/W)	73	70	70	50
R19 (°C/W)	53	45	45	35

Table 15. Thermal parameters⁽¹⁾ (continued)

Area/island (cm ²)	FP	2	8	4L
C1 (W·s/°C)	0.015			
C2 (W·s/°C)	0.1			
C3 (W·s/°C)	0.4	0.4	0.4	0.3
C4 (W·s/°C)	0.8	1	1.2	1.5
C5 (W·s/°C)	3	4	6	15
C6 (W·s/°C)	0.015			
C7 (W·s/°C)	0.015			
C8 (W·s/°C)	0.05			
C9 (W·s/°C)	0.3			
C10 (W·s/°C)	0.8	1	1	1.5
C11 (W·s/°C)	4	5	6	15
C12 (W·s/°C)	0.015			
C13 (W·s/°C)	0.05			
C14 (W·s/°C)	0.3			
C15 (W·s/°C)	0.8	1	1	1.5
C16 (W·s/°C)	4	5	6	15

1. The blank space means that the value is the same as the previous one.

4 Package information

In order to meet environmental requirements, ST offers these devices in different grades of ECOPACK® packages, depending on their level of environmental compliance. ECOPACK® specifications, grade definitions and product status are available at: www.st.com.

ECOPACK® is an ST trademark.

4.1 PowerSSO-36 TP package information

Figure 13. PowerSSO-36 TP package outline

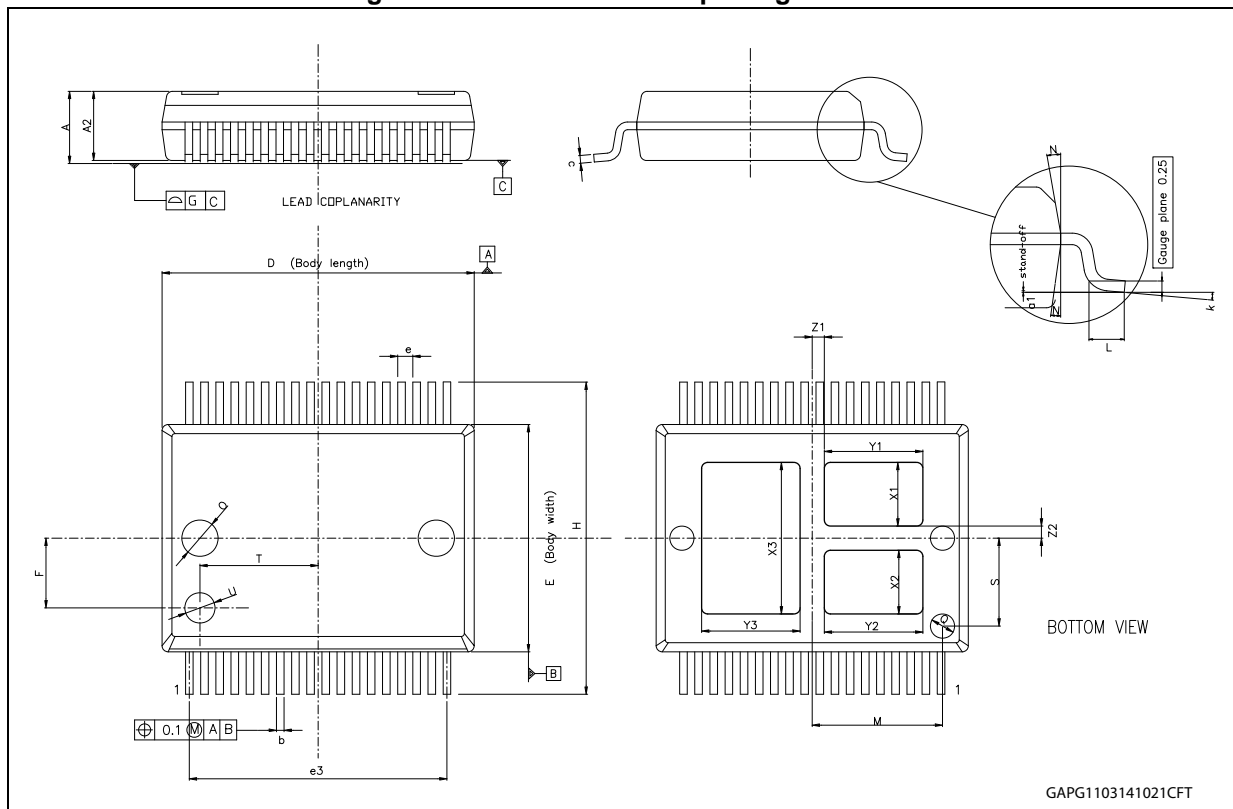

Table 16. PowerSSO-36 TP mechanical data

Symbol	Millimeters		
	Min.	Typ.	Max.
A	2.15		2.47
A2	2.15		2.40
a1	0		0.1
b	0.18		0.36
c	0.23		0.32
D	10.10		10.50
E	7.4		7.6
e		0.5	
e3		8.5	
F		2.3	
G			0.1
H	10.1		10.5
h			0.4
k	0 deg		8 deg
L	0.6		1
M		4.3	
N			10 deg
O		1.2	
Q		0.8	
S		2.9	
T		3.65	
U		1.0	
X1	1.85		2.35
Y1	3		3.5
X2	1.85		2.35
Y2	3		3.5
X3	4.7		5.2
Y3	3		3.5
Z1		0.4	
Z2		0.4	

4.2 PowerSSO-36 TP packing information

Figure 14. PowerSSO-36 TP tube shipment (no suffix)

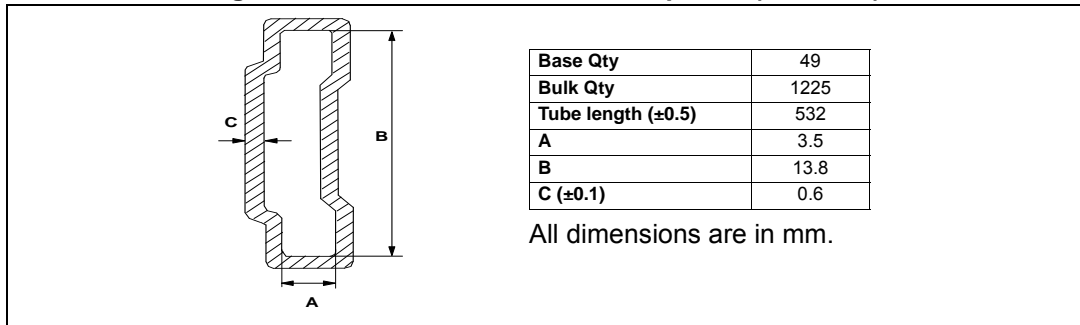
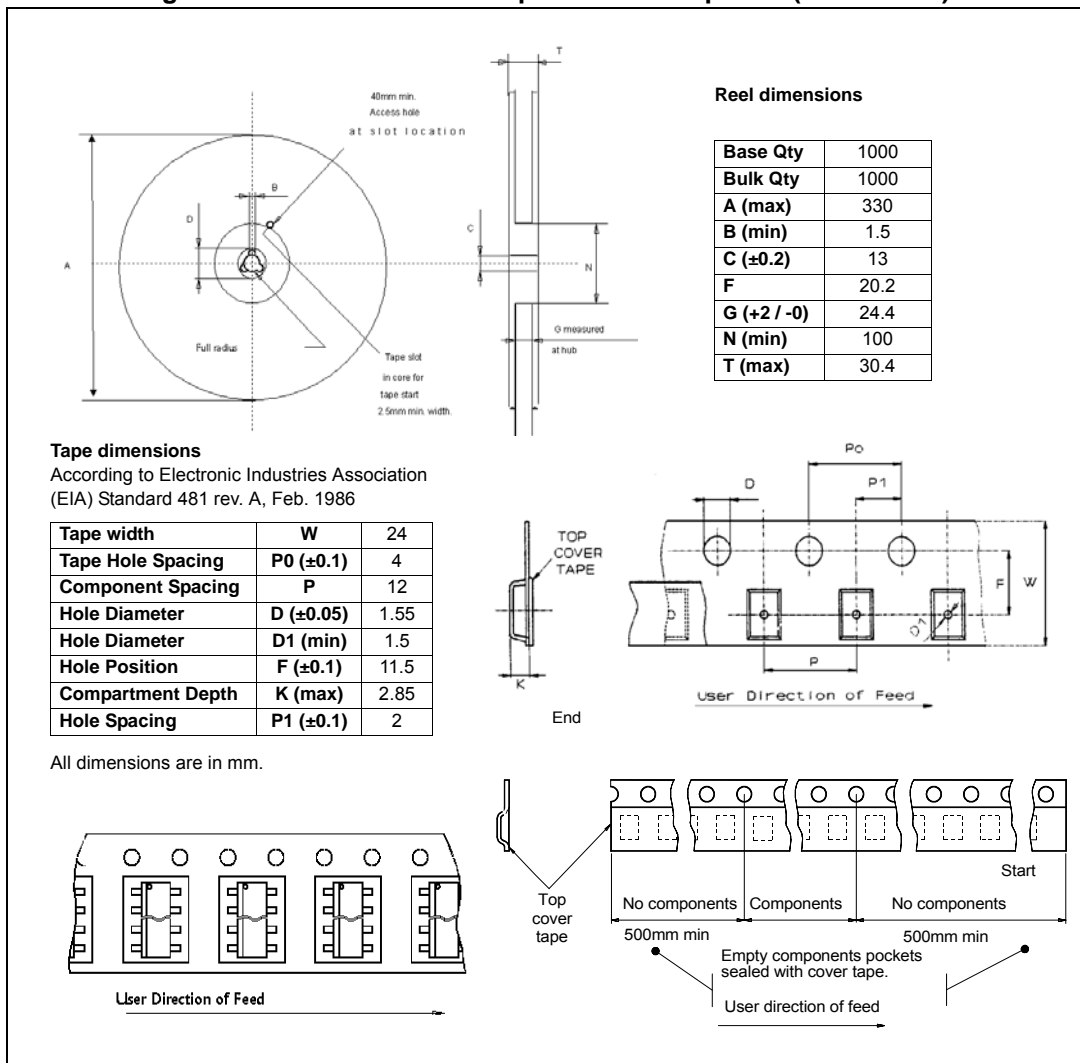
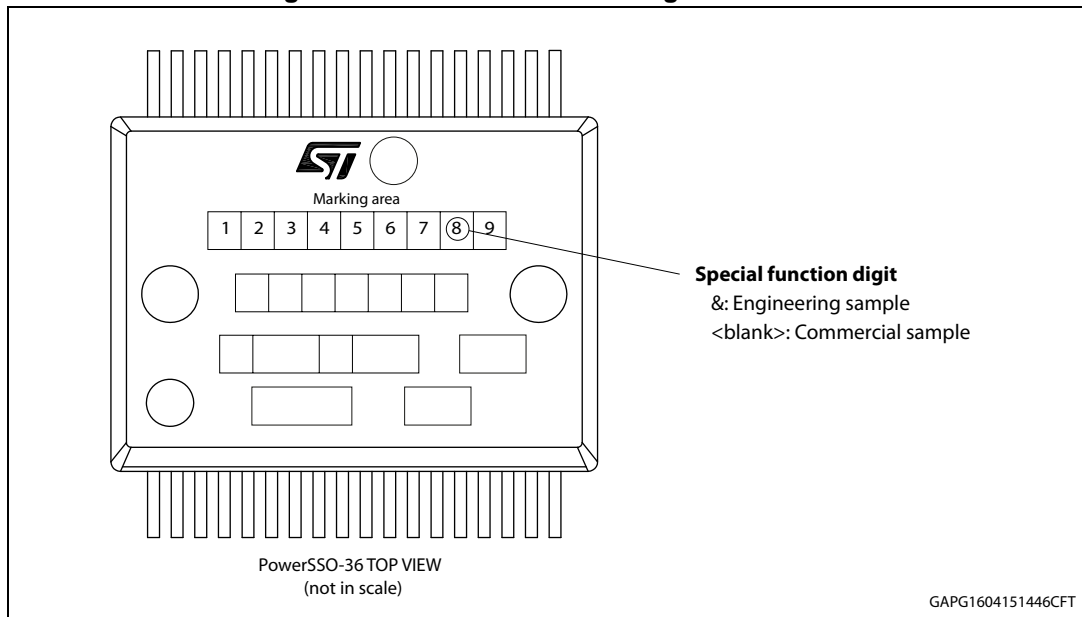

Figure 15. PowerSSO-36 TP tape and reel shipment (suffix "TR")



4.3 PowerSSO-36 marking information

Figure 16. PowerSSO-36 marking information



Note: Parts marked as "&" are not yet qualified and therefore not approved for use in production. ST is not responsible for any consequences resulting from such use. In no event will ST be liable for the customer using any of these engineering samples in production. ST's Quality department must be contacted prior to any decision to use these engineering samples to run a qualification activity.

Note: Commercial Samples: fully qualified parts from ST standard production with no usage restrictions.

5 Revision history

Table 17. Document revision history

Date	Revision	Changes
14-Oct-2015	1	Initial release
26-Apr-2016	2	Updated following tables: – <i>Table 4: Power off</i> – <i>Table 5: Power on</i> – <i>Table 6: Dynamic</i> – <i>Table 7: Gate resistance</i> – <i>Table 8: Source drain diode</i> – <i>Table 9: Switching on HSD</i> – <i>Table 10: Switching on LSD</i> – <i>Table 11: Switching off HSD</i> – <i>Table 12: Switching off LSD</i> – <i>Table 13: Thermal sensor</i>
20-Jun-2016	3	Updated <i>Table 3: Absolute maximum rating</i> , <i>Table 5: Power on</i> , <i>Table 6: Dynamic</i> , <i>Table 7: Gate resistance</i> , <i>Table 8: Source drain diode</i> , <i>Table 9: Switching on HSD</i> , <i>Table 10: Switching on LSD</i> and <i>Table 13: Thermal sensor</i> . Document status changed from target to preliminary data.
13-Jul-2016	4	Updated <i>Table 4: Power off</i>
28-Nov-2016	5	Removed table thermal data on page 8. Updated Section 4: Package information . Added Section 3: Package and PCB thermal data . Minor text changes.
17-Jan-2017	6	Updated Features Updated following tables: – Table 3: Absolute maximum rating – Table 6: Dynamic – Table 7: Gate resistance – Table 8: Source drain diode – Table 9: Switching on HSD – Table 10: Switching on LSD – Table 11: Switching off HSD – Table 12: Switching off LSD – Table 13: Thermal sensor

IMPORTANT NOTICE – PLEASE READ CAREFULLY

STMicroelectronics NV and its subsidiaries ("ST") reserve the right to make changes, corrections, enhancements, modifications, and improvements to ST products and/or to this document at any time without notice. Purchasers should obtain the latest relevant information on ST products before placing orders. ST products are sold pursuant to ST's terms and conditions of sale in place at the time of order acknowledgement.

Purchasers are solely responsible for the choice, selection, and use of ST products and ST assumes no liability for application assistance or the design of Purchasers' products.

No license, express or implied, to any intellectual property right is granted by ST herein.

Resale of ST products with provisions different from the information set forth herein shall void any warranty granted by ST for such product.

ST and the ST logo are trademarks of ST. All other product or service names are the property of their respective owners.

Information in this document supersedes and replaces information previously supplied in any prior versions of this document.

© 2017 STMicroelectronics – All rights reserved



Компания «ЭлектроПласт» предлагает заключение долгосрочных отношений при поставках импортных электронных компонентов на взаимовыгодных условиях!

Наши преимущества:

- Оперативные поставки широкого спектра электронных компонентов отечественного и импортного производства напрямую от производителей и с крупнейших мировых складов;
- Поставка более 17-ти миллионов наименований электронных компонентов;
- Поставка сложных, дефицитных, либо снятых с производства позиций;
- Оперативные сроки поставки под заказ (от 5 рабочих дней);
- Экспресс доставка в любую точку России;
- Техническая поддержка проекта, помощь в подборе аналогов, поставка прототипов;
- Система менеджмента качества сертифицирована по Международному стандарту ISO 9001;
- Лицензия ФСБ на осуществление работ с использованием сведений, составляющих государственную тайну;
- Поставка специализированных компонентов (Xilinx, Altera, Analog Devices, Intersil, Interpoint, Microsemi, Aeroflex, Peregrine, Syfer, Eurofarad, Texas Instrument, Miteq, Cobham, E2V, MA-COM, Hittite, Mini-Circuits, General Dynamics и др.);

Помимо этого, одним из направлений компании «ЭлектроПласт» является направление «Источники питания». Мы предлагаем Вам помощь Конструкторского отдела:

- Подбор оптимального решения, техническое обоснование при выборе компонента;
- Подбор аналогов;
- Консультации по применению компонента;
- Поставка образцов и прототипов;
- Техническая поддержка проекта;
- Защита от снятия компонента с производства.



Как с нами связаться

Телефон: 8 (812) 309 58 32 (многоканальный)

Факс: 8 (812) 320-02-42

Электронная почта: org@eplast1.ru

Адрес: 198099, г. Санкт-Петербург, ул. Калинина, дом 2, корпус 4, литера А.