



# One-to-Four LVCMOS-to-LVPECL Output Clock and Data Driver

MAX9323

## General Description

The MAX9323 low-skew, low-jitter, clock and data driver distributes one of two single-ended LVCMOS inputs to four differential LVPECL outputs. A single logic control signal (CLK\_SEL) selects the input signal to distribute to all outputs. The device operates from 3.0V to 3.6V, making the device ideal for 3.3V systems, and consumes only 25mA (max) of supply current.

The MAX9323 features low 150ps part-to-part skew, low 11ps output-to-output skew, and low 1.7ps RMS jitter, making the device ideal for clock and data distribution across a backplane or board. All outputs are enabled and disabled synchronously with the clock input to prevent partial output clock pulses.

The MAX9323 is available in space-saving 20-pin TSSOP and ultra-small 20-pin 4mm x 4mm thin QFN packages and operates over the extended (-40°C to +85°C) temperature range. The MAX9323 is pin compatible with Integrated Circuit Systems' ICS8535-01.

## Applications

- Precision Clock Distribution
- Low-Jitter Data Repeater
- Data and Clock Driver and Buffer
- Central-Office Backplane Clock Distribution
- DSLAM Backplane
- Base Station
- Hubs

## Features

- ◆ 1.7psRMS Added Random Jitter
- ◆ 150ps (max) Part-to-Part Skew
- ◆ 11ps Output-to-Output Skew
- ◆ 450ps Propagation Delay
- ◆ Pin Compatible with ICS8535-01
- ◆ Consumes Only 25mA (max) Supply Current (50% Less than ICS8535-01)
- ◆ Synchronous Output Enable/Disable
- ◆ Two Selectable LVCMOS Inputs
- ◆ 3.0V to 3.6V Supply Voltage Range
- ◆ -40°C to +85°C Operating Temperature Range

## Ordering Information

PART	TEMP RANGE	PIN-PACKAGE
MAX9323EUP	-40°C to +85°C	20 TSSOP
MAX9323ETP*	-40°C to +85°C	20 Thin QFN-EP**

\*Future product—Contact factory for availability.

\*\*EP = Exposed paddle.

Functional Diagram and Typical Operating Circuit appear at end of data sheet.

## Pin Configurations

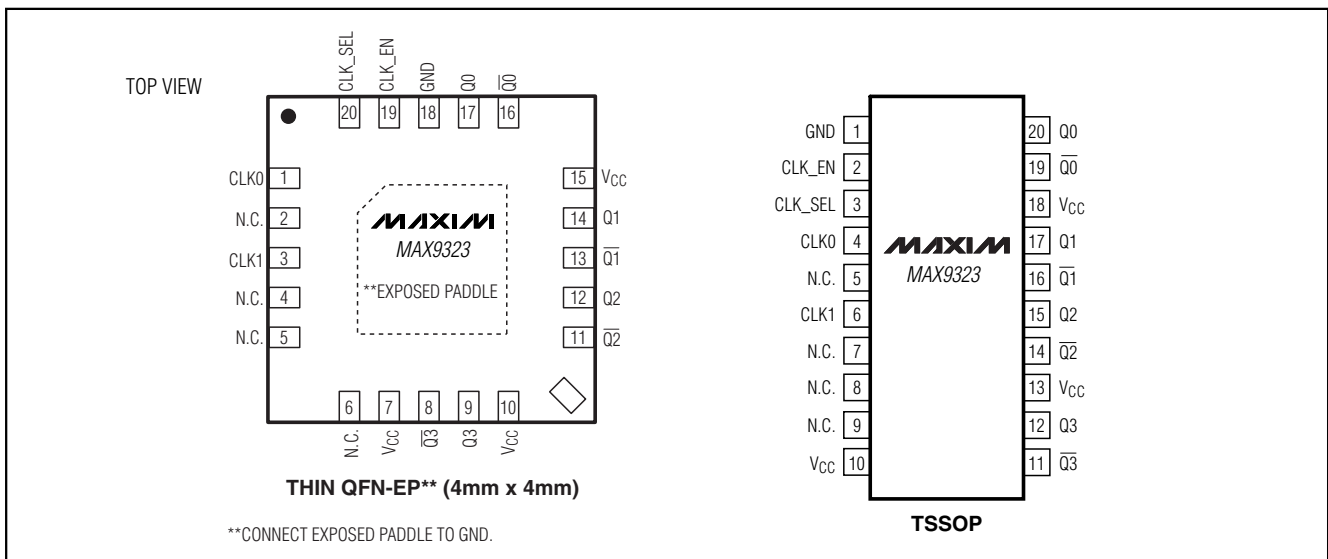

# One-to-Four LVCMOS-to-LVPECL Output Clock and Data Driver

## ABSOLUTE MAXIMUM RATINGS

V <sub>CC</sub> to GND	-0.3V to +4.0V	Junction-to-Case Thermal Resistance	
Q <sub>-</sub> , $\overline{Q}_-$ , CLK <sub>-</sub> , CLK_SEL, CLK_EN to GND	-0.3V to (V <sub>CC</sub> + 0.3V)	20-Pin TSSOP	+20°C/W
Continuous Output Current	50mA	20-Pin 4mm × 4mm Thin QFN	+2°C/W
Surge Output Current	100mA	Operating Temperature Range	-40°C to +85°C
Continuous Power Dissipation (T <sub>A</sub> = +70°C)		Junction Temperature	+150°C
20-Pin TSSOP (derate 11mW/°C)	879.1mW	Storage Temperature Range	-65°C to +150°C
20-Pin 4mm × 4mm Thin QFN (derate 16.9mW/°C)	1349.1mW	Soldering Temperature (10s)	+300°C
Junction-to-Ambient Thermal Resistance in Still Air			
20-Pin TSSOP	+91°C/W		
20-Pin 4mm × 4mm Thin QFN	+59.3°C/W		

Stresses beyond those listed under "Absolute Maximum Ratings" may cause permanent damage to the device. These are stress ratings only, and functional operation of the device at these or any other conditions beyond those indicated in the operational sections of the specifications is not implied. Exposure to absolute maximum rating conditions for extended periods may affect device reliability.

## DC ELECTRICAL CHARACTERISTICS

(V<sub>CC</sub> = 3.0V to 3.6V, outputs terminated with 50Ω ±1% to (V<sub>CC</sub> - 2V), CLK\_SEL = V<sub>CC</sub> or GND, CLK\_EN = V<sub>CC</sub>, T<sub>A</sub> = -40°C to +85°C, unless otherwise noted. Typical values are at V<sub>CC</sub> = 3.3V, T<sub>A</sub> = +25°C.) (Notes 1, 2, and 3)

PARAMETER	SYMBOL	CONDITIONS	MIN	TYP	MAX	UNITS
<b>INPUTS (CLK0, CLK1, CLK_SEL, CLK_EN)</b>						
Input High Voltage	V <sub>IH</sub>	Figure 1	CLK0, CLK1	2	V <sub>CC</sub>	V
			CLK_EN, CLK_SEL	2	V <sub>CC</sub>	
Input Low Voltage	V <sub>IL</sub>	Figure 1	CLK0, CLK1	0	1.3	V
			CLK_EN, CLK_SEL	0	0.8	
Input High Current	I <sub>IH</sub>	CLK0, CLK1, CLK_SEL = V <sub>CC</sub>			150	μA
		CLK_EN = V <sub>CC</sub>		-5	+5	
Input Low Current	I <sub>IL</sub>	CLK0, CLK1, CLK_SEL = GND		-5	+5	μA
		CLK_EN = GND		-150		
Input Capacitance	C <sub>IN</sub>	CLK0, CLK1, CLK_SEL, CLK_EN (Note 4)			4	pF
<b>OUTPUTS (Q<sub>-</sub>, <math>\overline{Q}_-</math>)</b>						
Single-Ended Output High Voltage	V <sub>OH</sub>	Figure 1		V <sub>CC</sub> - 1.4	V <sub>CC</sub> - 1.0	V
Single-Ended Output Low Voltage	V <sub>OL</sub>	Figure 1		V <sub>CC</sub> - 2.0	V <sub>CC</sub> - 1.7	V
Differential Output Voltage	V <sub>OD</sub>	Figure 1, V <sub>OD</sub> = V <sub>OH</sub> - V <sub>OL</sub>		0.6	0.85	V
<b>SUPPLY</b>						
Supply Current (Note 5)	I <sub>CC</sub>				25	mA

# One-to-Four LVCMOS-to-LVPECL Output Clock and Data Driver

MAX9323

## AC ELECTRICAL CHARACTERISTICS

( $V_{CC} = 3.0V$  to  $3.6V$ , outputs terminated with  $50\Omega \pm 1\%$  to  $(V_{CC} - 2V)$ ,  $f_{IN} < 266MHz$ , input duty cycle = 50%, input transition time = 1.1ns (20% to 80%),  $V_{IH} = V_{CC}$ ,  $V_{IL} = GND$ ,  $CLK\_SEL = V_{CC}$  or  $GND$ ,  $CLK\_EN = V_{CC}$ ,  $T_A = -40^{\circ}C$  to  $+85^{\circ}C$ , unless otherwise noted. Typical values are at  $V_{CC} = 3.3V$ ,  $T_A = +25^{\circ}C$ .) (Note 4)

PARAMETER	SYMBOL	CONDITIONS	MIN	TYP	MAX	UNITS
Switching Frequency	$f_{MAX}$	$V_{OH} - V_{OL} \geq 0.6V$	266	800		MHz
		$V_{OH} - V_{OL} \geq 0.3V$	1500			
Propagation Delay	$t_{PHL}$ , $t_{PLH}$	CLK0 or CLK1 to $Q_{-}$ , $\overline{Q_{-}}$ , Figure 1 (Note 6)	100	450	600	ps
Output-to-Output Skew	$t_{SKOO}$	(Note 7)			30	ps
Part-to-Part Skew	$t_{SKPP}$	(Note 8)			150	ps
Output Rise Time	$t_R$	20% to 80%, Figure 1	100	203	300	ps
Output Fall Time	$t_F$	80% to 20%, Figure 1	100	198	300	ps
Output Duty Cycle	ODC		48	50	52	%
Added Random Jitter	$t_{RJ}$	$f_{IN} = 266MHz$ , clock pattern (Note 9)		1.7	3	ps(RMS)
Added Jitter (Note 9)	$t_{AJ}$	$V_{CC} = 3.3V$ with 25mV superimposed sinusoidal noise at 100kHz			10	ps(P-P)

**Note 1:** Measurements are made with the device in thermal equilibrium.

**Note 2:** Positive current flows into a pin. Negative current flows out of a pin.

**Note 3:** DC parameters are production tested at  $T_A = +25^{\circ}C$  and guaranteed by design over the full operating temperature range.

**Note 4:** Guaranteed by design and characterization. Limits are set at  $\pm 6$  sigma.

**Note 5:** All pins open except  $V_{CC}$  and  $GND$ .

**Note 6:** Measured from the 50% point of the input to the crossing point of the differential output signal.

**Note 7:** Measured between outputs of the same part at the differential signal crosspoint for a same-edge transition.

**Note 8:** Measured between outputs of different parts at the differential signal crosspoint under identical conditions for a same-edge transition.

**Note 9:** Jitter added to the input signal.

# One-to-Four LVCMOS-to-LVPECL Output Clock and Data Driver

## Typical Operating Characteristics

( $V_{CC} = 3.3V$ , outputs terminated to ( $V_{CC} - 2V$ ) through  $50\Omega$ ,  $CLK\_SEL = V_{CC}$  or GND,  $CLK\_EN = V_{CC}$ ,  $T_A = +25^\circ C$ .)

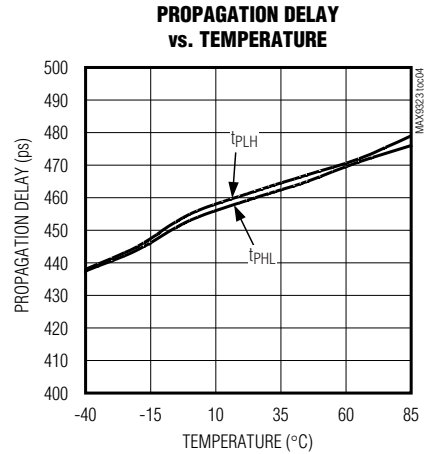
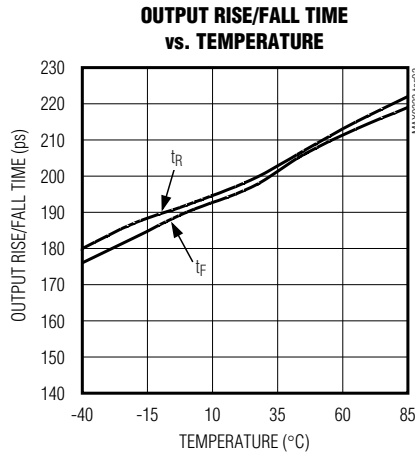
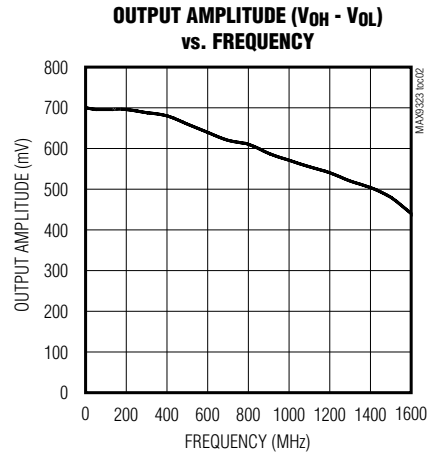
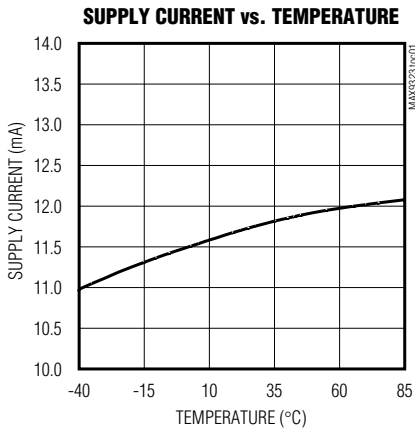

# One-to-Four LVCMOS-to-LVPECL Output Clock and Data Driver

## Pin Description

MAX9323

PIN		NAME	FUNCTION
TSSOP	QFN		
1	18	GND	Ground. Provide a low-impedance connection to the ground plane.
2	19	CLK_EN	Synchronous Output Enable. Connect CLK_EN to V <sub>CC</sub> or leave floating to enable the differential outputs. Connect CLK_EN to GND to disable the differential outputs. When disabled, Q <sub>-</sub> asserts low and Q <sub>-</sub> asserts high. An internal 51kΩ pullup resistor to V <sub>CC</sub> allows CLK_EN to be left floating.
3	20	CLK_SEL	Clock Select Input. Connect CLK_SEL to V <sub>CC</sub> to select the CLK1 input. Connect CLK_SEL to GND or leave floating to select the CLK0 input. Only the selected CLK <sub>-</sub> signal is reproduced at each output. An internal 51kΩ pulldown resistor to GND allows CLK_SEL to be left floating.
4	1	CLK0	LVCMOS Clock Input. When CLK_SEL = GND, each set of outputs differentially reproduces CLK0. An internal 51kΩ pulldown resistor to GND forces the outputs (Q <sub>-</sub> , Q <sub>-</sub> ) to differential low when CLK0 is left open or at GND, CLK_SEL = GND, and the outputs are enabled.
5, 7, 8, 9	2, 4, 5, 6	N.C.	No Connect. Not internally connected.
6	3	CLK1	LVCMOS Clock Input. When CLK_SEL = V <sub>CC</sub> , each set of outputs differentially reproduces CLK1. An internal 51kΩ pulldown resistor to GND forces the outputs (Q <sub>-</sub> , Q <sub>-</sub> ) to differential low when CLK1 is left open or at GND, CLK_SEL = V <sub>CC</sub> , and the outputs are enabled.
10, 13, 18	7, 10, 15	V <sub>CC</sub>	Positive Supply Voltage. Bypass V <sub>CC</sub> to GND with three 0.01μF and one 0.1μF ceramic capacitors. Place the 0.01μF capacitors as close to each V <sub>CC</sub> input as possible (one per V <sub>CC</sub> input). Connect all V <sub>CC</sub> inputs together, and bypass to GND with a 0.1μF ceramic capacitor.
11	8	Q3	Inverting Differential LVPECL Output. Terminate Q3 to (V <sub>CC</sub> - 2V) with a 50Ω ±1% resistor.
12	9	Q3	Noninverting Differential LVPECL Output. Terminate Q3 to (V <sub>CC</sub> - 2V) with a 50Ω ±1% resistor.
14	11	Q2	Inverting Differential LVPECL Output. Terminate Q2 to (V <sub>CC</sub> - 2V) with a 50Ω ±1% resistor.
15	12	Q2	Noninverting Differential LVPECL Output. Terminate Q2 to (V <sub>CC</sub> - 2V) with a 50Ω ±1% resistor.
16	13	Q1	Inverting Differential LVPECL Output. Terminate Q1 to (V <sub>CC</sub> - 2V) with a 50Ω ±1% resistor.
17	14	Q1	Noninverting Differential LVPECL Output. Terminate Q1 to (V <sub>CC</sub> - 2V) with a 50Ω ±1% resistor.
19	16	Q0	Inverting Differential LVPECL Output. Terminate Q0 to (V <sub>CC</sub> - 2V) with a 50Ω ±1% resistor.
20	17	Q0	Noninverting Differential LVPECL Output. Terminate Q0 to (V <sub>CC</sub> - 2V) with a 50Ω ±1% resistor.

### Detailed Description

The MAX9323 low-skew, low-jitter, clock and data driver distributes one of two single-ended LVCMOS input signals to four differential LVPECL outputs. An input multiplexer allows selection of one of the two input signals. The output drivers operate at frequencies up to 1.5GHz. The MAX9323 operates from 3.0V to 3.6V, making it ideal for 3.3V systems.

### Data Inputs

#### Single-Ended LVCMOS Inputs

The MAX9323 accepts two single-ended LVCMOS inputs (CLK0 and CLK1, Figure 1). An internal reference (V<sub>CC</sub>/2) provides the input threshold voltage for CLK0 and CLK1. CLK\_SEL selects the CLK0 input or CLK1 input to be converted to four differential LVPECL signals (see Table 1). Connect CLK\_SEL to GND to

select CLK0. Connect CLK\_SEL to V<sub>CC</sub> to select CLK1. CLK0 and CLK1 are pulled to GND through internal 51kΩ resistors, when not connected.

#### CLK\_EN Input

CLK\_EN enables/disables the differential outputs of the MAX9323. Connect CLK\_EN to V<sub>CC</sub> to enable the differential outputs. The (Q<sub>-</sub>, Q<sub>-</sub>) outputs are driven to a differential low condition when CLK\_EN = GND. Each differential output pair disables following successive rising and falling edges on CLK<sub>-</sub>, after CLK\_EN connects to GND. Both a rising and falling edge on CLK<sub>-</sub> are required to complete the enable/disable function (Figure 2).

#### CLK\_SEL Input

CLK\_SEL selects which single-ended LVCMOS input signal is output differentially as four LVPECL signals. Connect CLK\_SEL to GND to select the CLK0 input.

# One-to-Four LVCMOS-to-LVPECL Output Clock and Data Driver

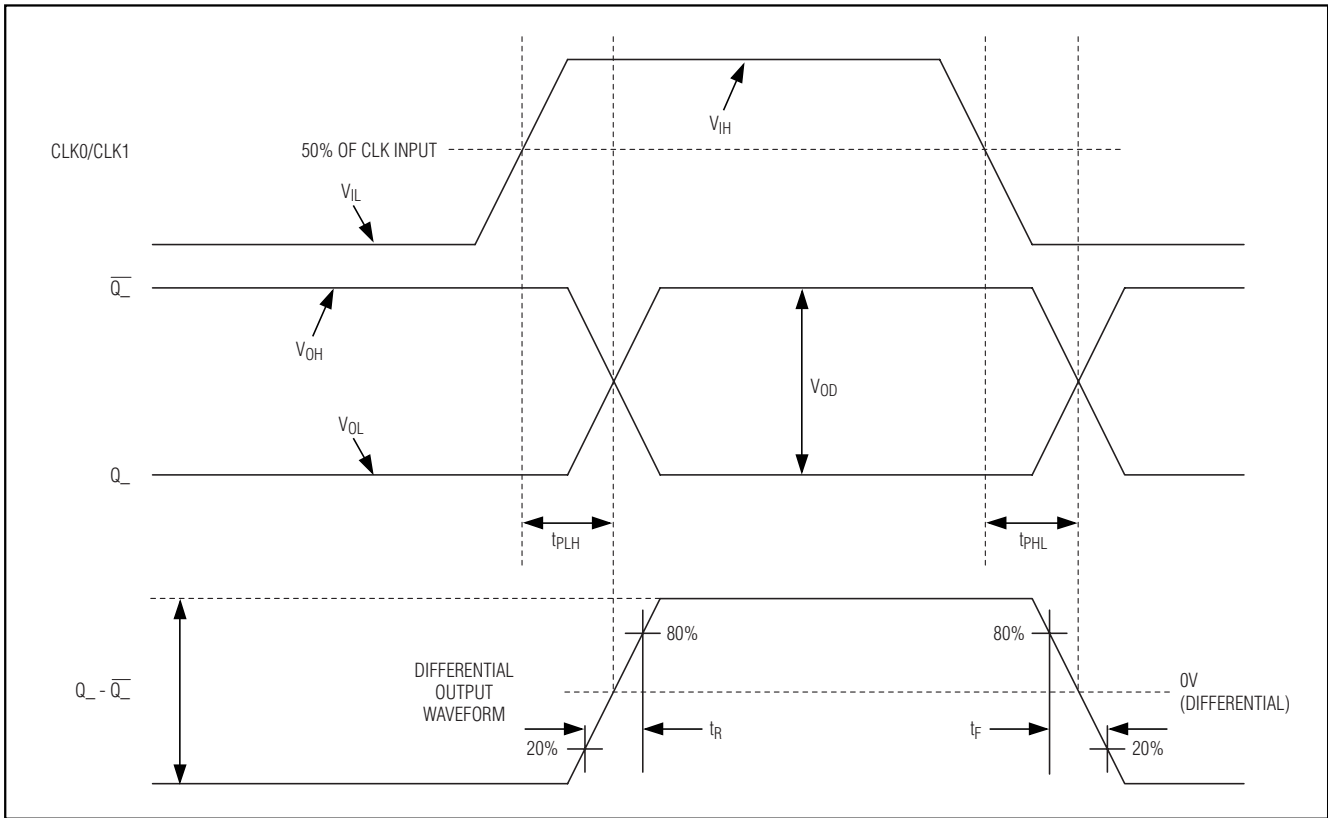

Figure 1. MAX9323 Clock Input-to-Output Delay and Rise/Fall Time

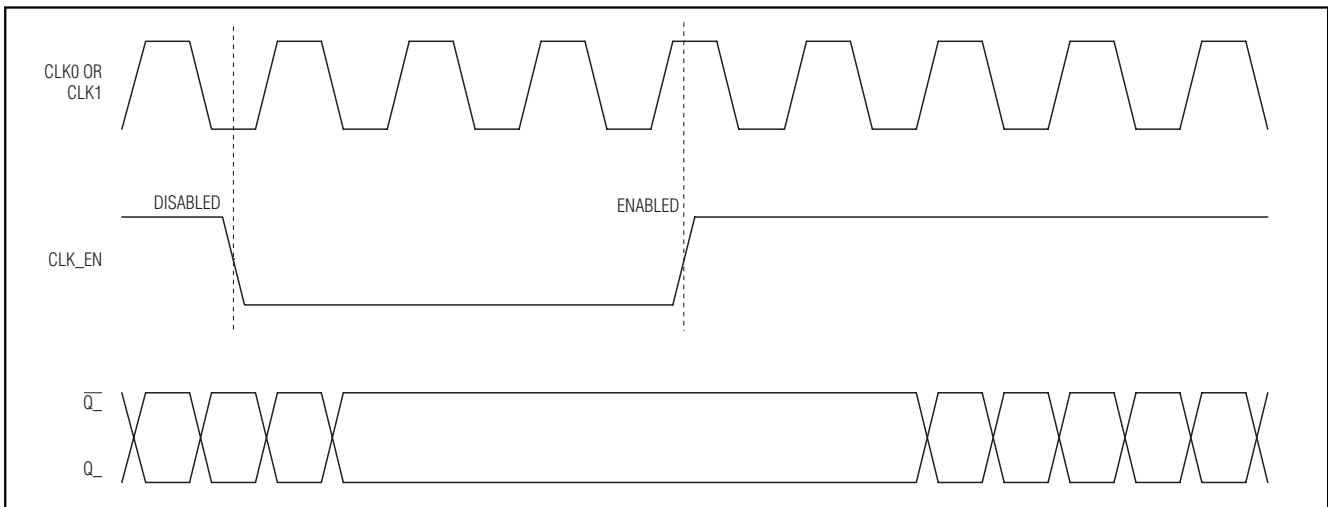

Figure 2. MAX9323 CLK\_EN Timing Diagram

# One-to-Four LVCMOS-to-LVPECL Output Clock and Data Driver

**Table 1. Control Input Table**

INPUTS			OUTPUTS	
CLK_EN	CLK_SEL	SELECTED SOURCE	Q0-Q3	$\overline{Q0-Q3}$
0	0	CLK0	Disabled, pulled to logic low	Disabled, pulled to logic high
0	1	CLK1	Disabled, pulled to logic low	Disabled, pulled to logic high
1	0	CLK0	Enabled	Enabled
1	1	CLK1	Enabled	Enabled

Connect CLK\_SEL to V<sub>CC</sub> to select the CLK1 input. An internal 51k $\Omega$  pulldown resistor to GND allows CLK\_SEL to be left floating.

## Applications Information

### Output Termination

Terminate both outputs of each differential pair through 50 $\Omega$  to (V<sub>CC</sub> - 2V) or use an equivalent Thevenin termination. Use identical termination on each output for the lowest output-to-output skew. Terminate both outputs when deriving a single-ended signal from a differential output. For example, using Q0 as a single-ended output requires termination for both Q0 and  $\overline{Q0}$ .

Ensure that the output currents do not violate the current limits as specified in the *Absolute Maximum Ratings* table. Observe the device's total thermal limits under all operating conditions.

### Power-Supply Bypassing

Bypass V<sub>CC</sub> to GND using three 0.01 $\mu$ F ceramic capacitors and one 0.1 $\mu$ F ceramic capacitor. Place the 0.01 $\mu$ F capacitors (one per V<sub>CC</sub> input) as close to V<sub>CC</sub> as possible (see the *Typical Operating Circuit*). Use multiple bypass vias to minimize parasitic inductance.

### Circuit Board Traces

Input and output trace characteristics affect the performance of the MAX9323. Connect each input and output to a 50 $\Omega$  characteristic impedance trace to minimize reflections. Avoid discontinuities in differential imped-

ance and maximize common-mode noise immunity by maintaining the distance between differential traces and avoiding sharp corners. Minimize the number of vias to prevent impedance discontinuities. Minimize skew by matching the electrical length of the traces.

## Chip Information

TRANSISTOR COUNT: 4430

PROCESS: BiCMOS

## Functional Diagram

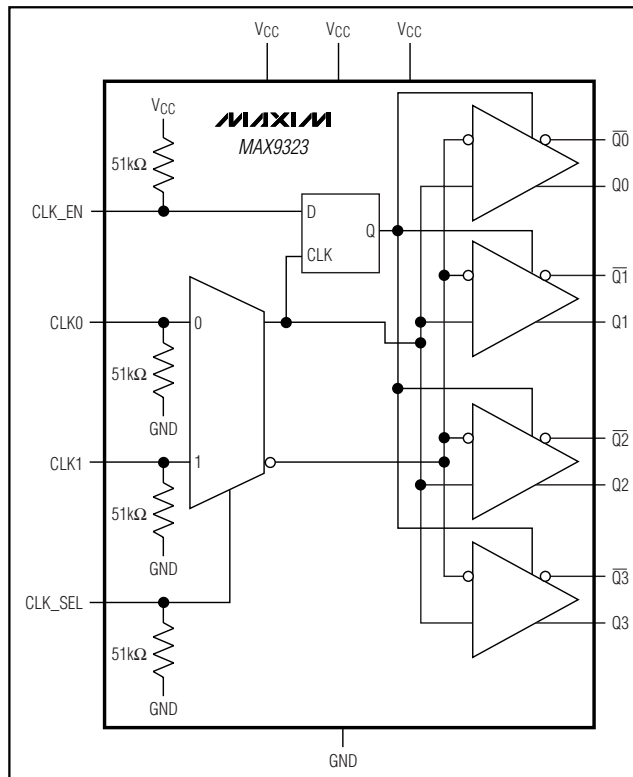

# One-to-Four LVCMOS-to-LVPECL Output Clock and Data Driver

## Typical Operating Circuit

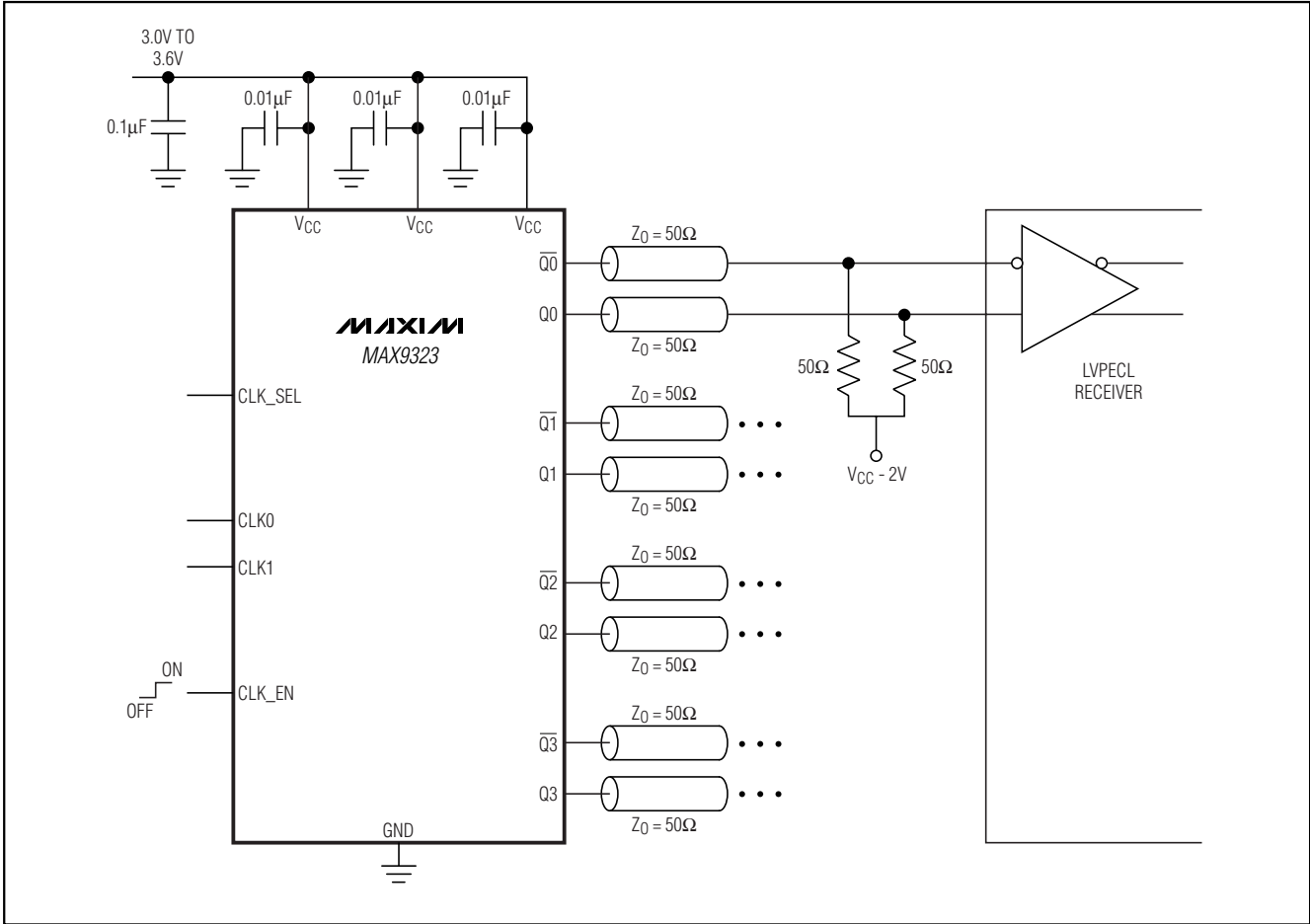



# One-to-Four LVCMOS-to-LVPECL Output Clock and Data Driver

## Package Information

(The package drawing(s) in this data sheet may not reflect the most current specifications. For the latest package outline information, go to [www.maxim-ic.com/packages](http://www.maxim-ic.com/packages).)

**MAX9323**

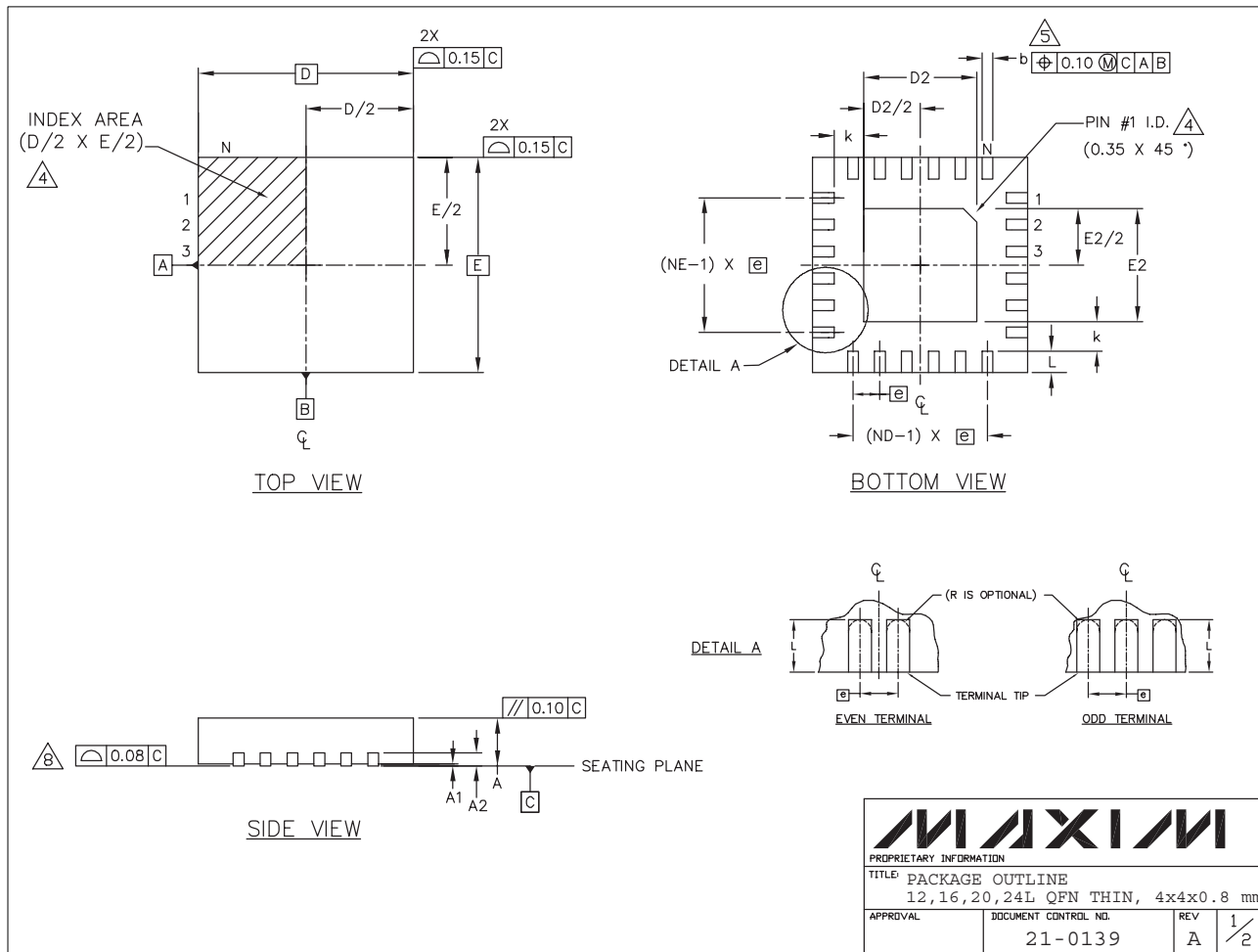

<b>MAXIM</b>			
PROPRIETARY INFORMATION			
TITLE PACKAGE OUTLINE			
12, 16, 20, 24L QFN THIN, 4x4x0.8 mm			
APPROVAL	DOCUMENT CONTROL NO.	REV	1/2
	21-0139	A	

# One-to-Four LVCMOS-to-LVPECL Output Clock and Data Driver

## Package Information (continued)

(The package drawing(s) in this data sheet may not reflect the most current specifications. For the latest package outline information, go to [www.maxim-ic.com/packages](http://www.maxim-ic.com/packages).)

COMMON DIMENSIONS												
PKG REF.	12L 4x4			16L 4x4			20L 4x4			24L 4x4		
	MIN.	NDM.	MAX.	MIN.	NDM.	MAX.	MIN.	NDM.	MAX.	MIN.	NDM.	MAX.
A	0.70	0.75	0.80	0.70	0.75	0.80	0.70	0.75	0.80	0.70	0.75	0.80
A1	0.0	0.02	0.05	0.0	0.02	0.05	0.0	0.02	0.05	0.0	0.02	0.05
A2	0.20 REF			0.20 REF			0.20 REF			0.20 REF		
b	0.25	0.30	0.35	0.25	0.30	0.35	0.20	0.25	0.30	0.18	0.23	0.30
D	3.90	4.00	4.10	3.90	4.00	4.10	3.90	4.00	4.10	3.90	4.00	4.10
E	3.90	4.00	4.10	3.90	4.00	4.10	3.90	4.00	4.10	3.90	4.00	4.10
e	0.80 BSC.			0.65 BSC.			0.50 BSC.			0.50 BSC.		
k	0.25	-	-	0.25	-	-	0.25	-	-	0.25	-	-
L	0.45	0.55	0.65	0.45	0.55	0.65	0.45	0.55	0.65	0.30	0.40	0.50
N	12			16			20			24		
ND	3			4			5			6		
NE	3			4			5			6		
JeDEC Var.	WGGB			WGGC			WGGD-1			WGGD-2		

EXPOSED PAD VARIATIONS								
PKG. CODES	D2			E2				
	MIN.	NDM.	MAX.	MIN.	NDM.	MAX.		
T1244-2	1.95	2.10	2.25	1.95	2.10	2.25		
T1644-2	1.95	2.10	2.25	1.95	2.10	2.25		
T2044-1	1.95	2.10	2.25	1.95	2.10	2.25		
T2444-1	2.45	2.60	2.63	2.45	2.60	2.63		

NOTES:

- DIMENSIONING & TOLERANCING CONFORM TO ASME Y14.5M-1994.
- ALL DIMENSIONS ARE IN MILLIMETERS. ANGLES ARE IN DEGREES.
- N IS THE TOTAL NUMBER OF TERMINALS.
- THE TERMINAL #1 IDENTIFIER AND TERMINAL NUMBERING CONVENTION SHALL CONFORM TO JEDEC 95-1 SPP-012. DETAILS OF TERMINAL #1 IDENTIFIER ARE OPTIONAL, BUT MUST BE LOCATED WITHIN THE ZONE INDICATED. THE TERMINAL #1 IDENTIFIER MAY BE EITHER A MOLD OR MARKED FEATURE.
- DIMENSION b APPLIES TO METALLIZED TERMINAL AND IS MEASURED BETWEEN 0.25 mm AND 0.30 mm FROM TERMINAL TIP.
- ND AND NE REFER TO THE NUMBER OF TERMINALS ON EACH D AND E SIDE RESPECTIVELY.
- DEPOPULATION IS POSSIBLE IN A SYMMETRICAL FASHION.
- COPLANARITY APPLIES TO THE EXPOSED HEAT SINK SLUG AS WELL AS THE TERMINALS.
- DRAWING CONFORMS TO JEDEC MO220.

PROPRIETARY INFORMATION			
TITLE: PACKAGE OUTLINE			
12, 16, 20, 24L QFN THIN, 4x4x0.8 mm			
APPROVAL	DOCUMENT CONTROL NO.	REV	
	21-0139	A	2/2

# One-to-Four LVCMOS-to-LVPECL Output Clock and Data Driver

## Package Information (continued)

(The package drawing(s) in this data sheet may not reflect the most current specifications. For the latest package outline information, go to [www.maxim-ic.com/packages](http://www.maxim-ic.com/packages).)

**MAX9323**

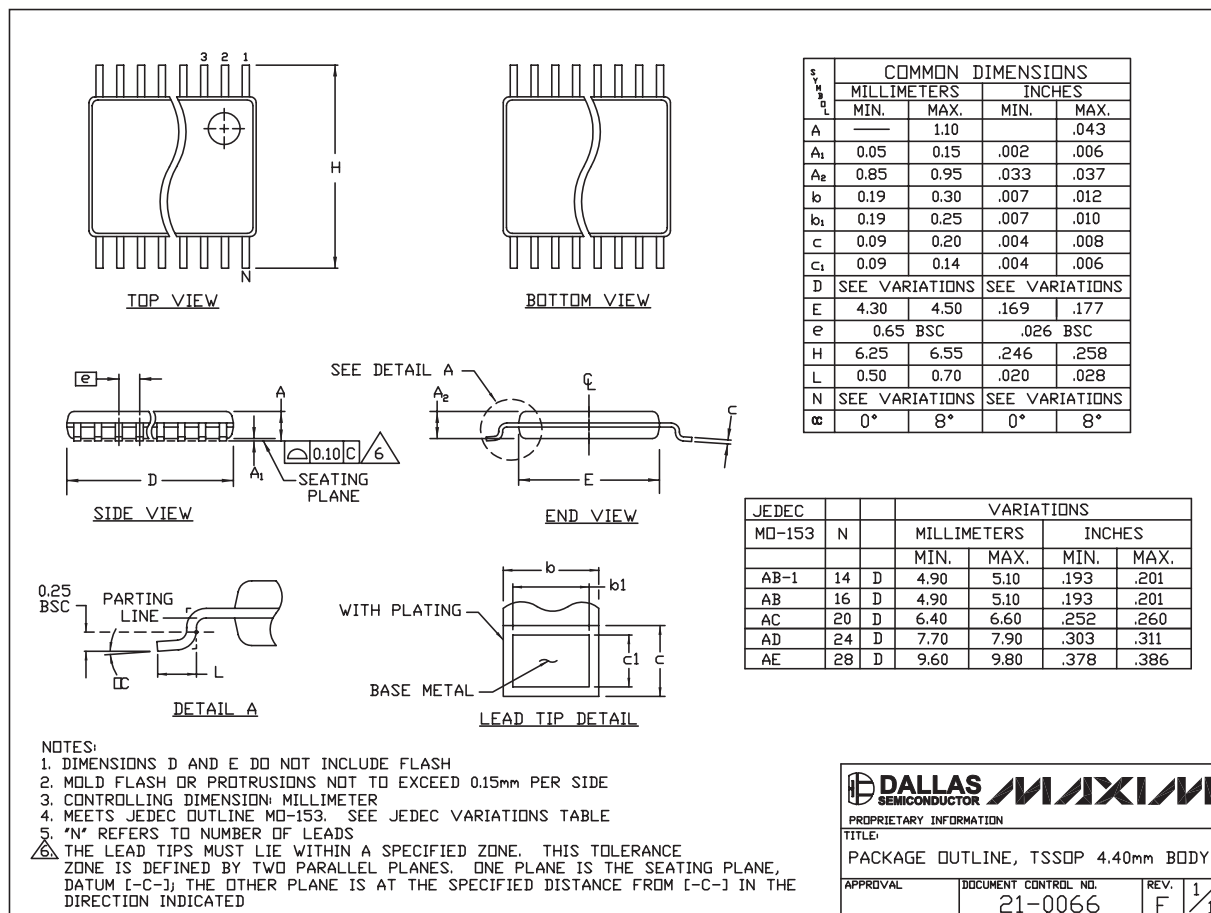

TSSOP4.40mm, EPS

Maxim cannot assume responsibility for use of any circuitry other than circuitry entirely embodied in a Maxim product. No circuit patent licenses are implied. Maxim reserves the right to change the circuitry and specifications without notice at any time.

Maxim Integrated Products, 120 San Gabriel Drive, Sunnyvale, CA 94086 408-737-7600 \_\_\_\_\_ 11



Компания «ЭлектроПласт» предлагает заключение долгосрочных отношений при поставках импортных электронных компонентов на взаимовыгодных условиях!

Наши преимущества:

- Оперативные поставки широкого спектра электронных компонентов отечественного и импортного производства напрямую от производителей и с крупнейших мировых складов;
- Поставка более 17-ти миллионов наименований электронных компонентов;
- Поставка сложных, дефицитных, либо снятых с производства позиций;
- Оперативные сроки поставки под заказ (от 5 рабочих дней);
- Экспресс доставка в любую точку России;
- Техническая поддержка проекта, помощь в подборе аналогов, поставка прототипов;
- Система менеджмента качества сертифицирована по Международному стандарту ISO 9001;
- Лицензия ФСБ на осуществление работ с использованием сведений, составляющих государственную тайну;
- Поставка специализированных компонентов (Xilinx, Altera, Analog Devices, Intersil, Interpoint, Microsemi, Aeroflex, Peregrine, Syfer, Eurofarad, Texas Instrument, Miteq, Cobham, E2V, MA-COM, Hittite, Mini-Circuits, General Dynamics и др.);

Помимо этого, одним из направлений компании «ЭлектроПласт» является направление «Источники питания». Мы предлагаем Вам помощь Конструкторского отдела:

- Подбор оптимального решения, техническое обоснование при выборе компонента;
- Подбор аналогов;
- Консультации по применению компонента;
- Поставка образцов и прототипов;
- Техническая поддержка проекта;
- Защита от снятия компонента с производства.



#### Как с нами связаться

**Телефон:** 8 (812) 309 58 32 (многоканальный)

**Факс:** 8 (812) 320-02-42

**Электронная почта:** [org@eplast1.ru](mailto:org@eplast1.ru)

**Адрес:** 198099, г. Санкт-Петербург, ул. Калинина, дом 2, корпус 4, литера А.