

Product Specification

40GBASE-SR4/10GBASE-SR 300m QSFP+ Gen3 Optical Transceiver Module

FTL410QD3C

PRODUCT FEATURES

- Four-channel full-duplex transceiver module
- Hot Pluggable QSFP+ form factor
- Maximum link length of 300m on OM3 Multimode Fiber (MMF) and 400m on OM4 MMF
- Multirate capability: 1.06Gb/s to 10.5Gb/s per channel
- Unretimed XLPP electrical interface
- Max power dissipation <1.2W
- Reliable VCSEL array technology
- Built-in digital diagnostic functions, including Tx and Rx power monitoring
- Commercial operating case temperature range: 0°C to 70°C
- Single 1x12 MPO receptacle
- RoHS-6 Compliant



APPLICATIONS

- 40GBASE-SR4 40G Ethernet
- Breakout to 10GBASE-SR Ethernet
- Proprietary interconnections

Finisar's FTL410QD3C QSFP+ transceiver modules are designed for use in 40 Gigabit per second links over parallel multimode fiber, including breakout to four 10 Gigabit per second links. They are compliant with the QSFP+ MSA^{1,2} and IEEE 802.3ba 40GBASE-SR4³ and compatible with IEEE 802.3ae 10GBASE-SR4⁴. The optical transceiver is compliant per the RoHS Directive 2011/65/EU⁵. See Finisar Application Note AN-2038 for more details⁶.

PRODUCT SELECTION

FTL410QD3C

I. Pin Descriptions

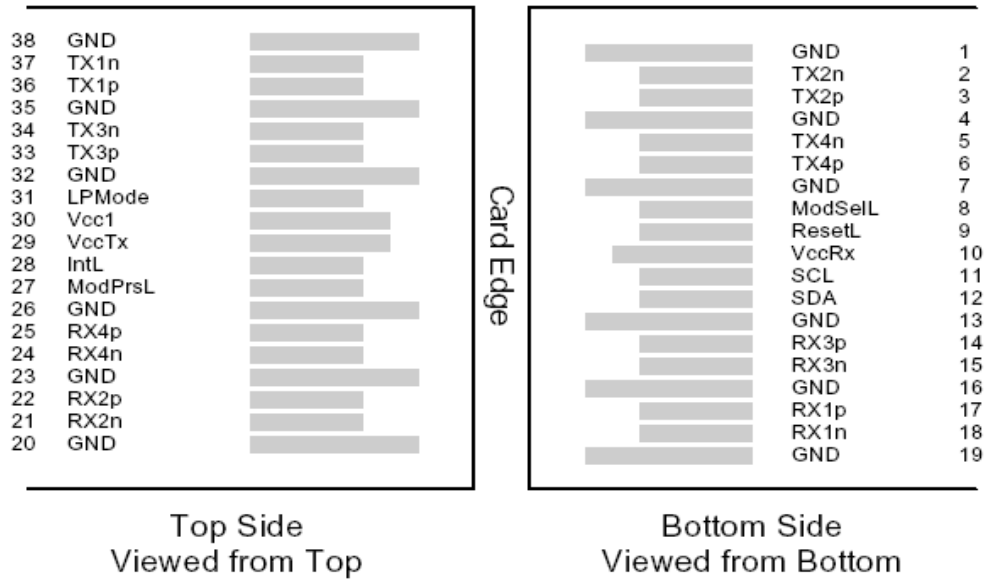

Figure 1 – QSFP+ MSA-compliant 38-pin connector

Pin	Symbol	Name/Description	Notes
1	GND	Ground	1
2	Tx2n	Transmitter Inverted Data Input	
3	Tx2p	Transmitter Non-Inverted Data Input	
4	GND	Ground	1
5	Tx4n	Transmitter Inverted Data Input	
6	Tx4p	Transmitter Non-Inverted Data Input	
7	GND	Ground	1
8	ModSelL	Module Select	
9	ResetL	Module Reset	
10	Vcc Rx	+3.3 V Power supply receiver	
11	SCL	2-wire serial interface clock	
12	SDA	2-wire serial interface data	
13	GND	Ground	1
14	Rx3p	Receiver Non-Inverted Data Output	
15	Rx3n	Receiver Inverted Data Output	
16	GND	Ground	1
17	Rx1p	Receiver Non-Inverted Data Output	
18	Rx1n	Receiver Inverted Data Output	
19	GND	Ground	1
20	GND	Ground	1
21	Rx2n	Receiver Inverted Data Output	
22	Rx2p	Receiver Non-Inverted Data Output	
23	GND	Ground	1
24	Rx4n	Receiver Inverted Data Output	
25	Rx4p	Receiver Non-Inverted Data Output	
26	GND	Ground	1

27	ModPrsL	Module Present	
28	IntL	Interrupt	
29	Vcc Tx	+3.3 V Power supply transmitter	
30	Vcc1	+3.3 V Power Supply	
31	LPMoDe	Low Power Mode	
32	GND	Ground	1
33	Tx3p	Transmitter Non-Inverted Data Input	
34	Tx3n	Transmitter Inverted Data Input	
35	GND	Ground	1
36	Tx1p	Transmitter Non-Inverted Data Input	
37	Tx1n	Transmitter Inverted Data Input	
38	GND	Ground	1

Notes

1. Circuit ground is internally isolated from chassis ground.

II. General Product Characteristics

Parameter	Value	Unit	Notes
Module Form Factor	QSFP+		
Number of Lanes	4 Tx and 4 Rx		
Maximum Aggregate Data Rate	42.0	Gb/s	
Maximum Data Rate per Lane	10.5	Gb/s	Higher bit rates may be supported. Please contact Finisar.
Protocols Supported	Typical applications include 40G Ethernet, Infiniband, Fibre Channel, SATA/SAS3		
Electrical Interface and Pin-out	38-pin edge connector		Pin-out as defined by the QSFP+ MSA ²
Maximum Power Consumption	1.2	Watts	Varies with output voltage swing and pre-emphasis settings
Management Interface	Serial, I2C-based, 400 kHz maximum frequency		As defined by the QSFP+ MSA ²

Data Rate Specifications	Symbol	Min	Typ	Max	Units	Ref.
Bit Rate per Lane	BR	1062		10500	Mb/sec	1
Bit Error Ratio	BER			10 ⁻¹²		2
Link distance on OM3 MMF	d			300	meters	3
Link distance on OM4 MMF	d			400	meters	3

Notes:

1. Compliant with 40G and 10G* Ethernet. Compatible with 1 Gigabit Ethernet and 1/2/4/8/10G Fibre Channel.
2. Tested with a PRBS 2³¹-1 test pattern.
3. Per 40GBASE-SR4 and 10GBASE-SR IEEE 802.3ba

* Max launch power exceeds 10G Ethernet specification by 1 dB, which is well within the guardband of receiver overload.

III. Absolute Maximum Ratings

Parameter	Symbol	Min	Typ	Max	Unit	Ref.
Maximum Supply Voltage	Vcc1, VccTx, VccRx	-0.5		3.6	V	
Storage Temperature	T _S	-40		85	°C	
Case Operating Temperature	T _{OP}	0		70	°C	
Relative Humidity	RH	0		85	%	1
Damage Threshold, per Lane	DT	3.4			dBm	

Notes:

1. Non-condensing.

IV. Electrical Characteristics (T_{OP} = 0 to 70°C, V_{CC} = 3.15 to 3.45 Volts)

Parameter	Symbol	Min	Typ	Max	Unit	Ref.
Supply Voltage	Vcc1, VccTx, VccRx	3.15		3.45	V	
Supply Current	I _{cc}			350	mA	
Link turn-on time						
Transmit turn-on time				2000	ms	2
Transmitter (per Lane)						
Single ended input voltage tolerance	V _{inT}	-0.3		4.0	V	
Differential data input swing	V _{in,pp}	180		1200	mV _{pp}	3
Differential input threshold			50		mV	
AC common mode input voltage tolerance (RMS)		15			mV	
Differential input return loss			Per IEEE P802.3ba, Section 86A.4.1.1		dB	4
J2 Jitter Tolerance	Jt2	0.17			UI	
J9 Jitter Tolerance	Jt9	0.29			UI	
Data Dependent Pulse Width Shrinkage	DDPWS	0.07			UI	
Eye mask coordinates {X1, X2 Y1, Y2}			0.11, 0.31 95, 350		UI mV	5

Receiver (per Lane)						
Single-ended output voltage		-0.3		4.0	V	
Differential data output swing	V _{out,pp}	0		800	mV _{pp}	6,7
AC common mode output voltage (RMS)				7.5	mV	
Termination mismatch at 1 MHz				5	%	
Differential output return loss		Per IEEE P802.3ba, Section 86A.4.2.1			dB	4
Common mode output return loss		Per IEEE P802.3ba, Section 86A.4.2.2			dB	4
Output transition time, 20% to 80%		28			ps	
J2 Jitter output	J _{o2}			0.42	UI	
J9 Jitter output	J _{o9}			0.65	UI	
Eye mask coordinates #1 {X1, X2 Y1, Y2}		0.29, 0.5 150, 425			UI mV	5
Power Supply Ripple Tolerance	PSR	50			mV _{pp}	

Notes:

1. Maximum total power value is specified across the full temperature and voltage range.
2. From power-on and end of any fault conditions.
3. After internal AC coupling. Self-biasing 100Ω differential input.
4. 10 MHz to 11.1 GHz range
5. Hit ratio = 5 x 10E-5.
6. AC coupled with 100Ω differential output impedance.
7. Settable in 4 discrete steps via the I2C interface.

V. Optical Characteristics (T_{OP} = 0 to 70°C, V_{CC} = 3.15 to 3.45 Volts)

Parameter	Symbol	Min	Typ	Max	Unit	Ref.
Transmitter (per Lane)						
Signaling Speed per Lane		1.00	10.3125	10.5	GBd	
Center wavelength		840		860	nm	
RMS Spectral Width	SW			0.40	nm	
Average Launch Power per Lane	TXP _x	-7.5		0	dBm	1
Transmit OMA per Lane	TxOMA			3.0	dBm	2
Difference in Power between any two lanes [OMA]	DP _x			4.0	dB	
Peak Power per Lane	PP _x			4.0	dBm	
Launch Power [OMA] minus TDP per Lane	P-TDP	-6.5			dBm	
TDP per Lane	TDP _{SR4}			3.5	dB	3
	TDP _{SR}			3.9		4
Optical Extinction Ratio	ER	3.0			dB	
Optical Return Loss Tolerance	ORL			12	dB	
Encircled Flux	FLX	> 86% at 19 um < 30% at 4.5 um			dBm	
Average launch power of OFF transmitter, per lane				-30	dBm	
Relative Intensity Noise	RIN			-128	dB/Hz	
Transmitter eye mask definition {X1, X2, X3, Y1, Y2, Y3}		0.23, 0.34, 0.43, 0.27, 0.35, 0.4				

Parameter	Symbol	Min	Typ	Max	Unit	Ref.
Receiver (per Lane)						
Signaling Speed per Lane		1.00	10.3125	10.5	GBd	
Center wavelength		840		860	nm	
Damage Threshold	DT	3.4			dBm	
Average Receive Power per Lane	RXP _x	-9.9		2.4	dBm	
Receive Power (OMA) per Lane	RxOMA			3.0	dBm	
Unstressed Receiver Sensitivity (OMA) per Lane	URS	-11.1			dBm	
Stressed Receiver Sensitivity (OMA) per Lane	SRS	-7.5			dBm	
Peak Power, per lane	PP _x			4	dBm	
Receiver Reflectance	Rfl			-12	dB	
Vertical eye closure penalty, per lane				3.5	dB	
Stressed eye J2 jitter, per Lane				0.3	UI	
Stressed eye J9 jitter, per Lane				0.47	UI	
OMA of each aggressor lane				-0.4	dBm	
Rx jitter tolerance: Jitter frequency and p-p amplitude		(75, 5)			kHz, UI	
		(375, 1)			kHz, UI	
LOS De-Assert	LOS _D			-12	dBm	
LOS Assert	LOS _A	-30			dBm	
LOS Hysteresis		0.5			dBm	

Notes:

- The maximum launch power of 0 dBm is well within the guardband of receiver overload specifications for commercially available 10GBASE-SR SFP+ transceivers from Finisar and other vendors.
- Even if TDP is <0.9dB, the OMA min must exceed the value given in the table below:

Center Wavelength (nm)	RMS Spectral width (nm)								
	Up to 0.05	0.05 to 0.1	0.1 to 0.15	0.15 to 0.2	0.2 to 0.25	0.25 to 0.3	0.3 to 0.35	0.35 to 0.4	0.4 to 0.45
840 to 842	-4.2	-4.2	-4.1	-4.1	-3.9	-3.8	-3.5	-3.2	-2.8
842 to 844	-4.2	-4.2	-4.2	-4.1	-3.9	-3.8	-3.6	-3.3	-2.9
844 to 846	-4.2	-4.2	-4.2	-4.1	-4.0	-3.8	-3.6	-3.3	-2.9
846 to 848	-4.3	-4.2	-4.2	-4.1	-4.0	-3.8	-3.6	-3.3	-2.9
848 to 850	-4.3	-4.2	-4.2	-4.1	-4.0	-3.8	-3.6	-3.3	-3.0
850 to 852	-4.3	-4.2	-4.2	-4.1	-4.0	-3.8	-3.6	-3.4	-3.0
852 to 854	-4.3	-4.2	-4.2	-4.1	-4.0	-3.9	-3.7	-3.4	-3.1
854 to 856	-4.3	-4.3	-4.2	-4.1	-4.0	-3.9	-3.7	-3.4	-3.1
856 to 858	-4.3	-4.3	-4.2	-4.1	-4.0	-3.9	-3.7	-3.5	-3.1
858 to 860	-4.3	-4.3	-4.2	-4.2	-4.1	-3.9	-3.7	-3.5	-3.2

- This TDP is up to 100m on OM3 and 150m on OM4.
- This TDP is up to 300m on OM3 and 400m on OM4.

VI. Memory Map and Control Registers

Compatible with the SFF-8436 QSFP+ MSA¹ and the SFF-8636 Common Management Interface MSA.² See Finisar Application Note AN-2119⁷ for a complete EEPROM memory map.

VII. Environmental Specifications

Finisar FTL410QD3C transceivers have an operating temperature range from 0°C to +70°C case temperature.

Environmental Specifications	Symbol	Min	Typ	Max	Units	Ref.
Case Operating Temperature	T _{op}	0		70	°C	
Storage Temperature	T _{sto}	-40		85	°C	

VIII. Regulatory Compliance

Finisar FTL410QD3C transceivers are RoHS-6 Compliant. Copies of certificates are available at Finisar Corporation upon request.

FTL410QD3C transceiver modules are Class 1 laser eye safety compliant per IEC 60825-1.

IX. Mechanical Specifications

The FTL410QD3C mechanical specifications are compliant to the QSFP+ MSA² transceiver module specifications.

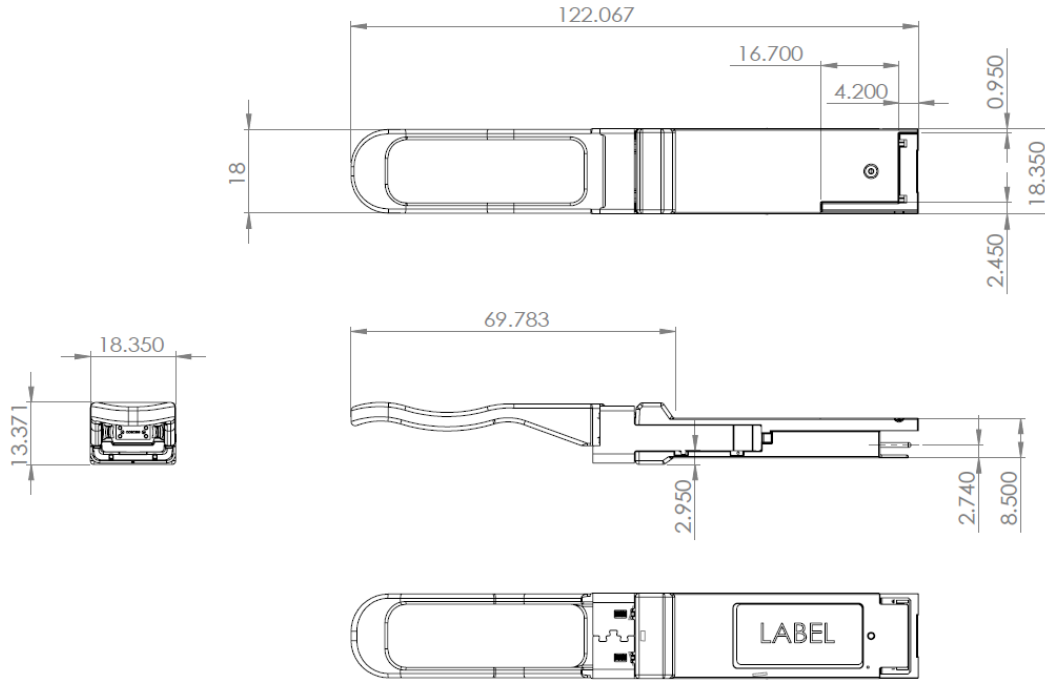

Figure 2 – FTL410QD3C mechanical drawing



Figure 3 – FTL410QD3C product label

The optical port is a male MPO connector receptacle, with fiber lane assignments as shown in Figure 4.

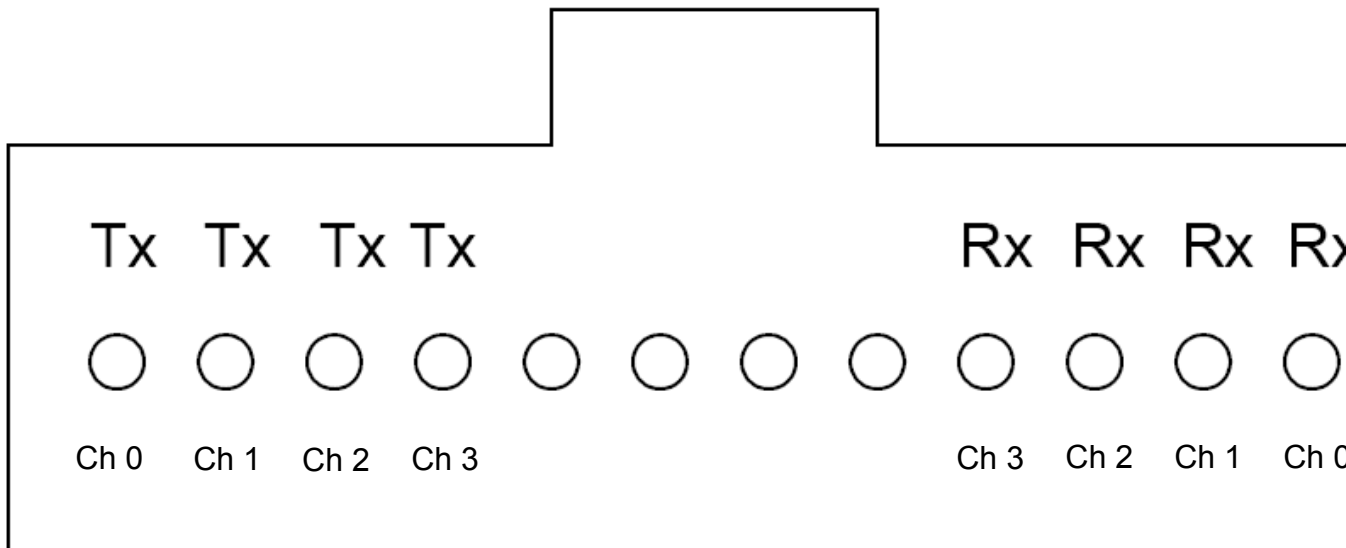

Figure 4 – FTL410QD3C optical lane assignment
 (front view of MPO receptacle)

X. References

1. SFF-8436 – Specification for QSFP+ 10 Gbs 4x Pluggable Transceiver, Rev 4.8, October 2013.
2. SFF-8636 – Specification for Common Management Interface, Rev 2.4, November 2014.
3. IEEE 802.3ba – PMD Type 40GBASE-SR4.
4. IEEE 802.3ae – PMD Type 10GBASE-SR.
5. Directive 2011/65/EU of the European Council Parliament and of the Council, “on the restriction of the use of certain hazardous substances in electrical and electronic equipment”. Certain products may use one or more exemptions as allowed by the Directive.
6. “Application Note AN-2038: Finisar Implementation of RoHS Compliant Transceivers”.
7. “Application Note AN-2119: QSFP+ 3rd Generation SR4 Transceiver – EEPROM Mapping”, Rev. B, Finisar Corporation, January, 2015.

XI. For More Information

Finisar Corporation
1389 Moffett Park Drive
Sunnyvale, CA 94089-1133
Tel. 1-408-548-1000
Fax 1-408-541-6138
sales@finisar.com
www.finisar.com



Компания «ЭлектроПласт» предлагает заключение долгосрочных отношений при поставках импортных электронных компонентов на взаимовыгодных условиях!

Наши преимущества:

- Оперативные поставки широкого спектра электронных компонентов отечественного и импортного производства напрямую от производителей и с крупнейших мировых складов;
- Поставка более 17-ти миллионов наименований электронных компонентов;
- Поставка сложных, дефицитных, либо снятых с производства позиций;
- Оперативные сроки поставки под заказ (от 5 рабочих дней);
- Экспресс доставка в любую точку России;
- Техническая поддержка проекта, помощь в подборе аналогов, поставка прототипов;
- Система менеджмента качества сертифицирована по Международному стандарту ISO 9001;
- Лицензия ФСБ на осуществление работ с использованием сведений, составляющих государственную тайну;
- Поставка специализированных компонентов (Xilinx, Altera, Analog Devices, Intersil, Interpoint, Microsemi, Aeroflex, Peregrine, Syfer, Eurofarad, Texas Instrument, Miteq, Cobham, E2V, MA-COM, Hittite, Mini-Circuits, General Dynamics и др.);

Помимо этого, одним из направлений компании «ЭлектроПласт» является направление «Источники питания». Мы предлагаем Вам помощь Конструкторского отдела:

- Подбор оптимального решения, техническое обоснование при выборе компонента;
- Подбор аналогов;
- Консультации по применению компонента;
- Поставка образцов и прототипов;
- Техническая поддержка проекта;
- Защита от снятия компонента с производства.



Как с нами связаться

Телефон: 8 (812) 309 58 32 (многоканальный)

Факс: 8 (812) 320-02-42

Электронная почта: org@eplast1.ru

Адрес: 198099, г. Санкт-Петербург, ул. Калинина, дом 2, корпус 4, литера А.