

# PGR-8800 SERIES (D1000)

## Arc-Flash Relay



### Description

The PGR-8800 is a microprocessor-based relay that limits arc-fault damage by detecting the light from an arc flash and rapidly tripping. Phase-current-transformer inputs are provided for current-constrained arc-flash protection and, when so equipped, a programmable definite-time overcurrent function can be enabled. An optical sensor on the PGR-8800 and adjustable trip level reduce the chance of nuisance tripping by setting a threshold for ambient light. Sensors, inputs, and connections are monitored to ensure fail-safe operation. A secondary solid-state trip circuit provides a redundant trip path. A USB port is used for configuration and access to event logs and graphs.

### Simplified Circuit Diagram

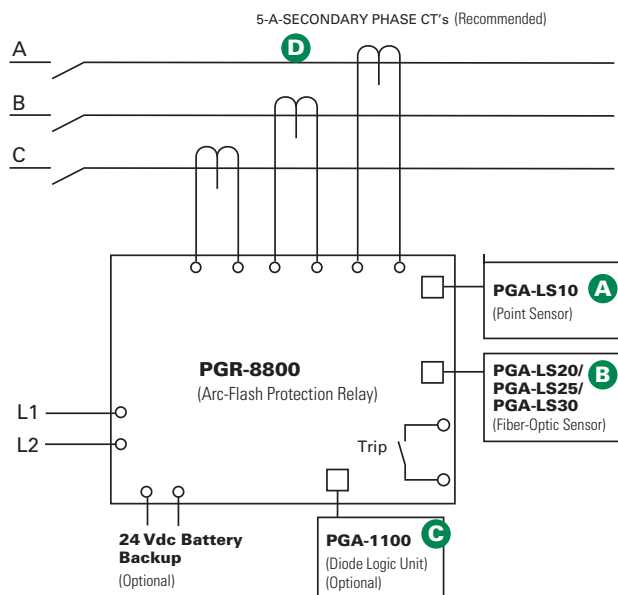

For detailed wiring diagram, see adjacent page.

### Ordering Information

ORDERING NUMBER	COMMUNICATIONS
PGR-8800-00 (UL, CE, C-tick)	Multi-unit linking, Modbus® RTU
ACCESSORIES	REQUIREMENT
PGA-LS10 (A1000)	Required*
PGA-LS20 (A2000)/ PGA-LS25 (A2000.0020) PGA-LS30 (A2000.0030)	Required*
PGA-1100 (D1100)	Optional
Current Transformer	Optional

\*At least one sensor is required. However, the exact number of sensors for proper coverage depends on the application.

### Optical Sensors

The PGR-8800 accepts both PGA-LS10 and PGA-LS20/PGA-LS25/PGA-LS30 optical sensors, designed to collect light over a wide angle and with high sensitivity. For fast fault location, front-panel and sensor LED's indicate sensor health and which sensor detected an arc fault.

### Sensor Placement

The PGR-8800 Arc-Flash Relay and sensors are easily installed in retrofit projects and new switchgear with little or no re-configuration. Even elaborate systems with multiple power sources take minutes to configure using the relay's built-in USB interface software.

Generally, it is recommended to mount 1 or 2 sensors per cubicle to cover all horizontal and vertical bus bars, breaker compartments, drawers, and anywhere that there is potential for an arc-fault. Threading a fiber-optic sensor through the cabinets and in areas where point-sensor coverage is uncertain results in complete coverage and an added level of redundancy. Even if policy is to only work on de-energized systems, all maintenance areas should be monitored to prevent potential damage and additional cost. At least one sensor should have visibility of an arc fault if a person blocks the other sensor(s).

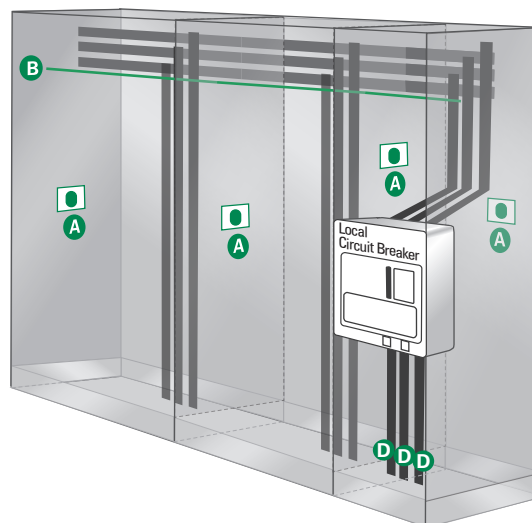

# PGR-8800 SERIES (D1000)

## Arc-Flash Relay



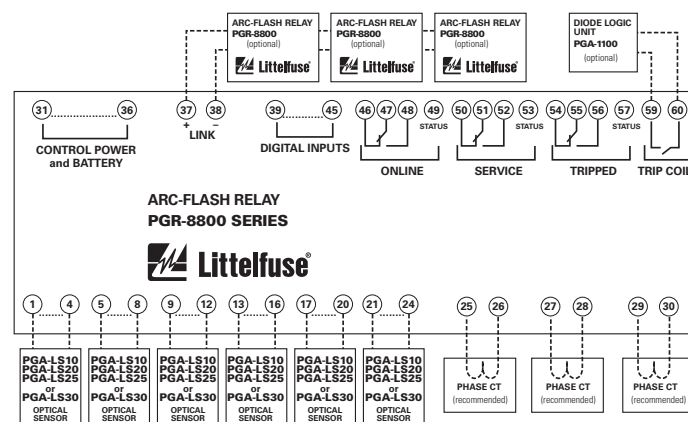

### Features & Benefits

FEATURES	BENEFITS
<b>Arc-Flash trip time &lt;1 ms</b>	Limits arc-flash damage and risk of injury
<b>Multiple sensors (up to 24)</b>	Single module can monitor 6 sensors. Up to 4 PGR-8800 units can be linked into one system
<b>Fail-safe system</b>	Continuous monitoring of optical sensors and inputs ensures protection
<b>Redundant trip circuit</b>	Solid-state backup arc-detection circuit adds a second layer of safety
<b>Adjustable light sensitivity</b>	Allows for operation in bright environments and maximum sensitivity in dark environments
<b>LED indication (on unit and each sensor)</b>	18 LEDs provide at-a glance status for module and I/O state
<b>Current detection</b>	Phase-CT inputs provide overcurrent protection and prevent nuisance trips
<b>Optical detection</b>	Point and fiber-optic sensors provide wide detection area with sensor health trip indication
<b>Digital inputs (6)</b>	Two each: remote trip, inhibit, and reset inputs
<b>Service mode</b>	Allows for system test without tripping
<b>Trip coil contact</b>	Solid-state 24-300 Vdc/24-300 Vac IGBT
<b>Indication contacts</b>	Form C and status outputs
<b>USB interface</b>	Data logging and configuration software uses a USB interface with no drivers or software installation
<b>Built-in sensor</b>	Can be used in single-sensor systems, as a seventh sensor, and for calibration
<b>Universal power supply/Battery backup</b>	100-240 Vac, 14-48 Vdc, or 110-250 Vdc supply accepted. Ability to charge and run off an external, user-supplied 24 Vdc battery.
<b>Data logging</b>	On-board event recorder helps with system diagnostics
<b>Modbus</b>	Remotely view measured values, event records & reset trips
<b>Upstream Tripping</b>	Ability to trip upstream device if the local breaker fails to clear the fault

### Wiring Diagram



### Accessories

- A**  **PGA-LS10 (A1000) Point Sensor**  
Line-of-sight light sensor detects an arc as small as 3 kA within a 2-m half-sphere. Sensor health and trip indication. Dimensions: See PGR-8800 Manual
- B**  **PGA-LS20 (A2000)/PGA-LS25 (A2000.0020)/PGA-LS30(A2000.0030) Fiber-Optic Sensor**  
360° light sensor for tricky installations with many shadows or to run along bus bars. Sensor health and trip indication. Dimensions: See PGR-8800 Manual
- C**  **PGA-1100 (D1100) Diode Logic Unit**  
This module allows multiple PGR-8800 relays to trip the same breaker, for example an upstream or a tie-breaker. Dimensions: **H** 80mm (3.15") **W** 20mm (.79") **D** 70mm (2.76")
- D**  **Current Transformers**  
Eliminate nuisance arc-flash trips and use for overcurrent protection.

### Specifications

<b>IEEE Device Numbers</b>	Overcurrent (50), Arc Flash (AFD)
<b>Input Voltage</b>	100-240 Vac, 14-48 Vdc, and 110-250 Vdc
<b>Dimensions</b>	<b>H</b> 130 mm (5.2"); <b>W</b> 200 mm (7.9"); <b>D</b> 54 mm (2.2")
<b>Optical Trip Settings</b>	9-25 klux, 800 μs-20 s
<b>Current Trip Setting (A)</b>	Programmable
<b>Indication Contact Mode</b>	Fail-safe
<b>Trip Coil Voltage<sup>(1)</sup></b>	24-300 Vdc, 24-300 Vac
<b>Trip Coil Contact Mode</b>	Selectable fail-safe or non-fail-safe
<b>Redundant Trip Circuit</b>	Standard feature
<b>Input Monitoring</b>	Standard feature
<b>USB Interface</b>	Standard feature
<b>Trip, Reset, Service Buttons</b>	Standard feature
<b>Expandable System</b>	Link up to 4 PGR-8800 units
<b>Warranty</b>	5 years
<b>Mounting</b>	DIN (with D0050 adapter clips), Surface

NOTE (1) - Contact Littelfuse for trip coil voltages higher than 300 Vdc/Vac.

Littelfuse reserves the right to make product changes, without notice. Material in this document is as accurate as known at the time of publication. Visit Littelfuse.com for the most up-to-date information.



Компания «ЭлектроПласт» предлагает заключение долгосрочных отношений при поставках импортных электронных компонентов на взаимовыгодных условиях!

Наши преимущества:

- Оперативные поставки широкого спектра электронных компонентов отечественного и импортного производства напрямую от производителей и с крупнейших мировых складов;
- Поставка более 17-ти миллионов наименований электронных компонентов;
- Поставка сложных, дефицитных, либо снятых с производства позиций;
- Оперативные сроки поставки под заказ (от 5 рабочих дней);
- Экспресс доставка в любую точку России;
- Техническая поддержка проекта, помощь в подборе аналогов, поставка прототипов;
- Система менеджмента качества сертифицирована по Международному стандарту ISO 9001;
- Лицензия ФСБ на осуществление работ с использованием сведений, составляющих государственную тайну;
- Поставка специализированных компонентов (Xilinx, Altera, Analog Devices, Intersil, Interpoint, Microsemi, Aeroflex, Peregrine, Syfer, Eurofarad, Texas Instrument, Miteq, Cobham, E2V, MA-COM, Hittite, Mini-Circuits, General Dynamics и др.);

Помимо этого, одним из направлений компании «ЭлектроПласт» является направление «Источники питания». Мы предлагаем Вам помощь Конструкторского отдела:

- Подбор оптимального решения, техническое обоснование при выборе компонента;
- Подбор аналогов;
- Консультации по применению компонента;
- Поставка образцов и прототипов;
- Техническая поддержка проекта;
- Защита от снятия компонента с производства.



#### Как с нами связаться

**Телефон:** 8 (812) 309 58 32 (многоканальный)

**Факс:** 8 (812) 320-02-42

**Электронная почта:** [org@eplast1.ru](mailto:org@eplast1.ru)

**Адрес:** 198099, г. Санкт-Петербург, ул. Калинина, дом 2, корпус 4, литера А.