

### DESCRIPTION

The MP3331 is a highly-efficient, 2A, single flash LED driver in a very compact package for high-resolution camera phones that improves image and video quality in low-light environments. The device operates in a 1/2/3/4MHz synchronous DC/DC boost converter to provide an optimized solution for smaller PCB spaces with higher efficiency.

The MP3331 features a standard I<sup>2</sup>C interface, single LED channel, rich protection modes, and high power density and performances. It supports flash/assist/torch/indicator/5V DC modes.

The cathode of the flash LED is referenced to GND, which improves thermal performance. It is available in a WLCSP9-1.7mm x 1.7mm package.

### FEATURES

- 2.7V to 5.5V Input Voltage
- 1/2/3/4MHz Selectable Switching Frequency
- Switching Frequency Foldback Function
- 400kHz I<sup>2</sup>C Compatible Interface
- Standby/Flash/Assist/Torch/Indicator/5V DC Mode

#### FLASH MODE:

- Up to 2A Programmable Current with +/-7% Accuracy

#### ASSIST/TORCH MODE:

- Up to 508mA Programmable Current with +/-7% Accuracy

#### INDICATOR MODE:

- Works in 31.5kHz PWM Dimming Mode with 2/16, 3/16, 4/16, 5/16 Duty Cycle

#### 5V DC MODE:

- Fixed 5V Output Voltage
- External Torch/Strobe Pin
- Low-Battery Voltage Protection
- Pre-Flash for Auto Detect Load Condition
- LED Short/Open Protection
- VOUT-GND Short Protection
- Over-Voltage Protection
- Over-Temperature Protection
- Input Under-Voltage Lockout Protection
- Thermal Protection
- Input to Output Disconnection Function
- Available in a WLCSP9-1.7mm x 1.7mm Package

### APPLICATIONS

- Camera Phone LED Flash
- Tablets
- Digital Still Camera

All MPS parts are lead-free, halogen-free, and adhere to the RoHS directive. For MPS green status, please visit the MPS website under Quality Assurance. "MPS" and "The Future of Analog IC Technology" are registered Trademarks of Monolithic Power Systems, Inc.

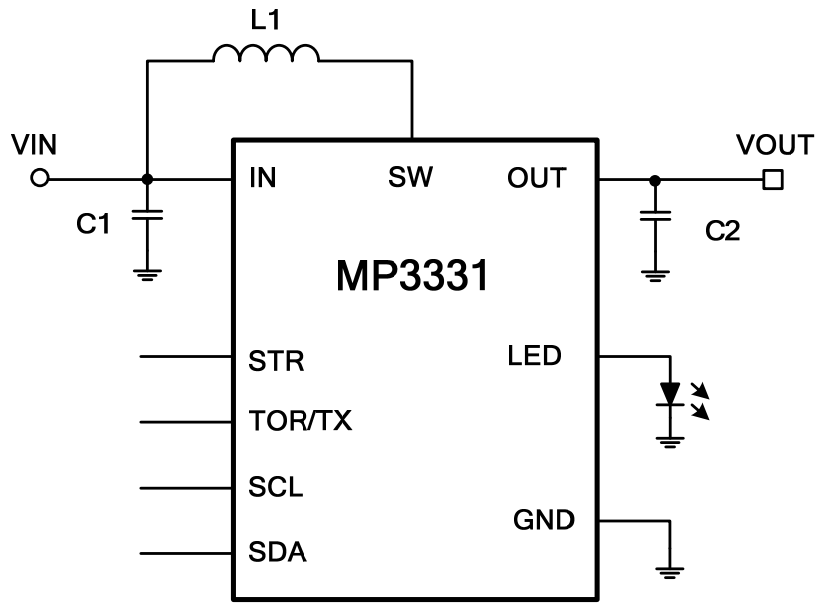
**TYPICAL APPLICATION**

**Typical Application Circuit**

### ORDERING INFORMATION

Part Number*	Package	Top Marking
MP3331GC	WLCSP-9 (1.7mm x 1.7mm)	See Below

\* For Tape & Reel, add suffix -Z (e.g. MP3331GC)

### TOP MARKING

—  
**CMY**  
**LLL**

CM: Product code of MP3331GC  
 Y: Year code  
 LLL: Lot number

### PACKAGE REFERENCE

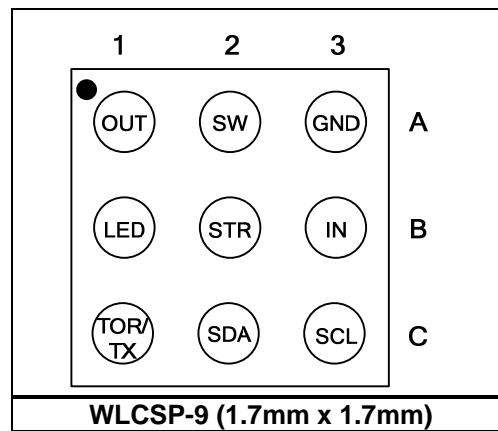

**ABSOLUTE MAXIMUM RATINGS** <sup>(1)</sup>

All the pins .....	-0.3V to +6V
Junction temperature .....	150°C
Lead temperature .....	260°C
Continuous power dissipation (T <sub>A</sub> = 25°C) <sup>(2)</sup>	
WLCSP-9 (1.7mm x 1.7mm).....	1.14W

**Recommended Operating Conditions** <sup>(3)</sup>

Supply voltage (V <sub>IN</sub> ) .....	2.7V to 5.5V
Operating junction temp.....	-40°C to +125°C

<b>Thermal Resistance</b> <sup>(4)</sup>	<b>θ<sub>JA</sub></b>	<b>θ<sub>JC</sub></b>
WLCSP-9 (1.7mm x 1.7mm)....	110....	0.5..°C/W

**NOTES:**

- 1) Exceeding these ratings may damage the device.
- 2) The maximum allowable power dissipation is a function of the maximum junction temperature T<sub>J</sub> (MAX), the junction-to-ambient thermal resistance θ<sub>JA</sub>, and the ambient temperature T<sub>A</sub>. The maximum allowable continuous power dissipation at any ambient temperature is calculated by P<sub>D</sub> (MAX) = (T<sub>J</sub> (MAX)-T<sub>A</sub>)/θ<sub>JA</sub>. Exceeding the maximum allowable power dissipation will produce an excessive die temperature, causing the regulator to go into thermal shutdown. Internal thermal shutdown circuitry protects the device from permanent damage.
- 3) The device is not guaranteed to function outside of its operating conditions.
- 4) Measured on JESD51-7, 4-layer PCB.

## ELECTRICAL CHARACTERISTICS

V<sub>IN</sub> = 3.6V, T<sub>A</sub> = 25°C, unless otherwise noted.

Parameters	Symbol	Condition	Min	Typ	Max	Units
<b>Supply</b>						
Operating input voltage	V <sub>IN</sub>		2.7		5.5	V
Input UVLO threshold	V <sub>IN_UVLO</sub>	Rising edge		2.5		V
Input UVLO hysteresis				150		mV
Standby current	I <sub>Q_STANDBY</sub>	V <sub>IN</sub> = 2.7V to 5.5V, I <sup>2</sup> C active			10	μA
Operating quiescent current	I <sub>Q</sub>	V <sub>IN</sub> = 3.6V, No switching, pass mode		0.95		mA
<b>Switching Regulator</b>						
Switching frequency	f <sub>s</sub>	F <sub>s</sub> = 4MHz	3.6	4	4.4	MHz
Minimum on time	t <sub>ON_MIN</sub>			50		ns
NMOS on resistance	R <sub>DSON_N</sub>	V <sub>IN</sub> = 3.6V		80		mΩ
PMOS on resistance	R <sub>DSON_P</sub>	V <sub>IN</sub> = 3.6V		120		mΩ
Constant DC output voltage	V <sub>OUT_5V</sub>	5V DC mode		5		V
Inductor current limit	I <sub>LIMIT</sub>	Code setting = 00, max duty cycle <sup>(5)</sup>		1.9		A
		Code setting = 11, max duty cycle <sup>(5)</sup>		4.2		A
<b>LED Driver</b>						
Flash current setting	I <sub>LED_FLASH</sub>	Flash mode, value setting = 000000		0		mA
		Flash mode, value setting = 001010	295	317	339	mA
Torch current setting	I <sub>LED_TORCH</sub>	Assist light/torch mode, value setting = 000000		0		mA
		Assist light /torch mode, value setting = 001010	295	317	339	mA
Current source headroom voltage	V <sub>HD</sub>	Current = 200mA		150		mV
		Current = 1500mA <sup>(5)</sup>		250		mV
Current ramp-up step time	t <sub>RAMP_UP</sub>	TUP_I = 000		8		μs
		TUP_I = 111		64		μs
Current ramp-down step time	t <sub>RAMP_DOWN</sub>			2		μs
Flash to TX current settling time	t <sub>SETTLE</sub>	TX from low to high, I <sub>LED</sub> from 1500mA to 31.7mA			5	μs
<b>Digital Input</b>						
Input logic-low voltage					0.4	V
Input logic-high Voltage			1.2			V

**ELECTRICAL CHARACTERISTICS (continued)**
**V<sub>IN</sub> = 3.6V, T<sub>A</sub> = 25°C, unless otherwise noted.**

Parameters	Symbol	Condition	Min	Typ	Max	Units
Strobe/Torch/TX pull-down resistor				250		kΩ
<b>Protection</b>						
Time-out time	t <sub>TIMEOUT</sub>	Time setting code = 0011	190	200	210	ms
Over-voltage threshold	V <sub>OVP</sub>		5.2	5.5	5.8	V
LED short detection voltage	V <sub>LED_ST</sub>			1		V
V <sub>OUT</sub> short blanking time	T <sub>OUT_ST</sub>	V <sub>OUT</sub> <V <sub>IN</sub> -1V and when enable bit is on.		5		ms
LED open detection voltage	V <sub>LED_OP</sub>			90		mV
Thermal shutdown threshold <sup>(5)</sup>	T <sub>J_SD</sub>			150		°C
Adaptive thermal threshold <sup>(5)</sup>				130		°C
Low-battery threshold	V <sub>BAT_LOW</sub>	Code Setting = 000		3.0		V
		Code Setting = 110		3.6		V
<b>I<sup>2</sup>C Interface</b>						
Input logic low	V <sub>IL</sub>		0		0.4	V
Input logic high	V <sub>IH</sub>		1.3V			V
Output logic low	V <sub>OL</sub>	I <sub>LOAD</sub> = 3mA			0.4	V
SCL clock frequency	F <sub>SCL</sub>				400	kHz
SCL high time	T <sub>HIGH</sub>		0.6			μs
SCL low time	T <sub>LOW</sub>		1.3			μs
Data setup time	T <sub>SU,DAT</sub>		100			ns
Data hold time	T <sub>HD,DAT</sub>		0		0.9	μs
Setup time for repeated start	T <sub>SU,STA</sub>		0.6			μs
Hold time for start	T <sub>HD,STA</sub>		0.6			μs
Bus free time between a start and a stop condition	T <sub>BUF</sub>		1.3			μs
Setup time for stop condition	T <sub>SU,STO</sub>		0.6			μs
Rise time of SCL and SDA	T <sub>R</sub>		20+0.1*C <sub>B</sub>		300	ns
Fall time of SCL and SDA	T <sub>F</sub>		20+0.1*C <sub>B</sub>		300	ns
Pulse width of suppressed spike	T <sub>SP</sub>		0		50	ns
Capacitance bus for each bus line	C <sub>B</sub>				400	pF

**NOTES:**

5) Guaranteed by design.

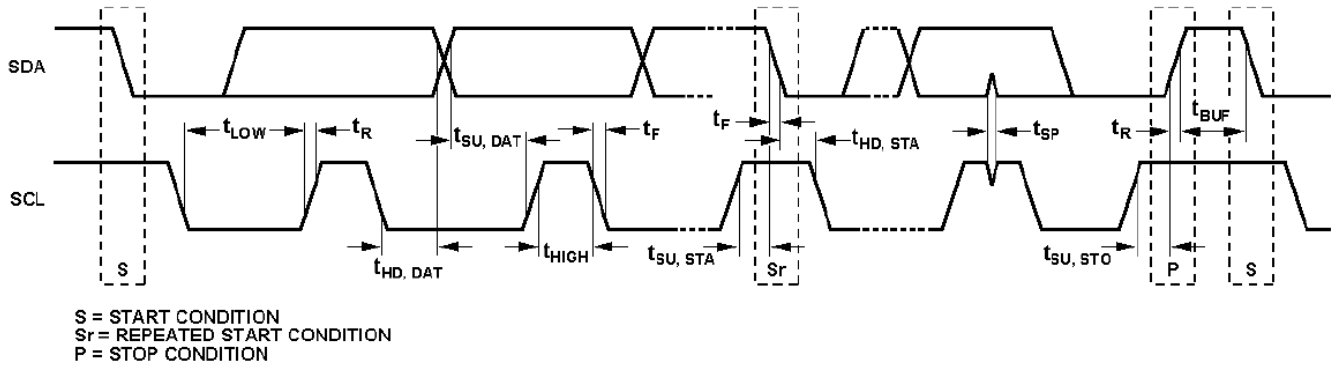

**Figure 1: I<sup>2</sup>C Compatible Interface Timing Diagram**

## TYPICAL PERFORMANCE CHARACTERISTICS

$V_{IN} = 3.3V$ , 1LED, FL\_TIM = 100ms, L = 1 $\mu$ H, T<sub>A</sub> = 25°C, unless otherwise noted.

### Torch/Assist Mode

I<sub>LED</sub> = 500mA

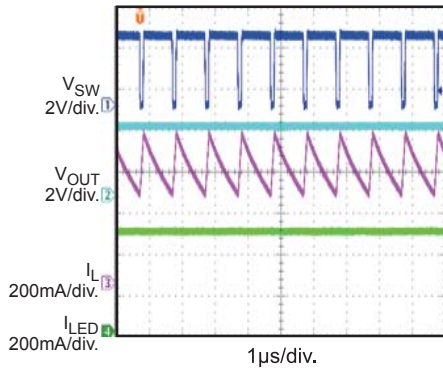

### Indicator Mode

Duty=2/16

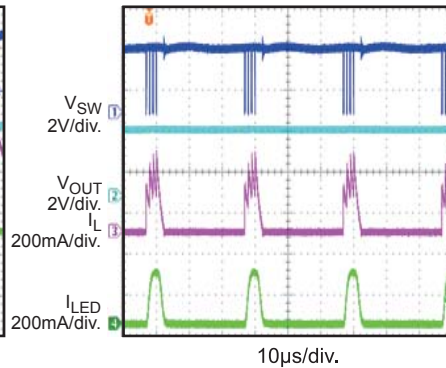

### Indicator Mode

Duty=5/16

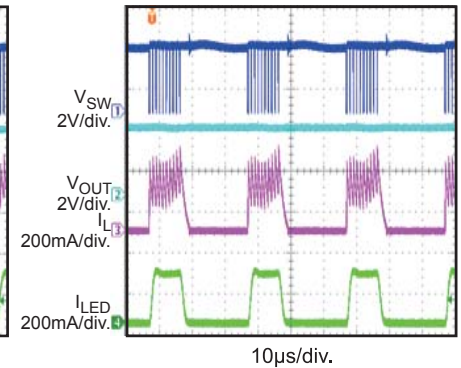

### Flash Mode

Hardware and Level Sensitive Mode

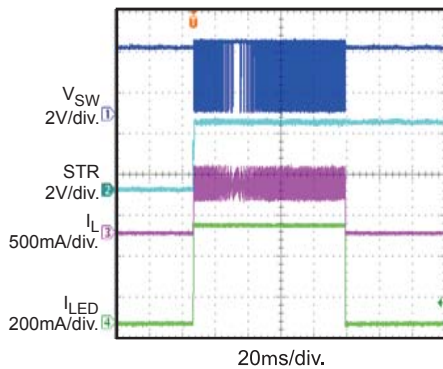

### Flash Mode

Hardware and Edge Sensitive Mode

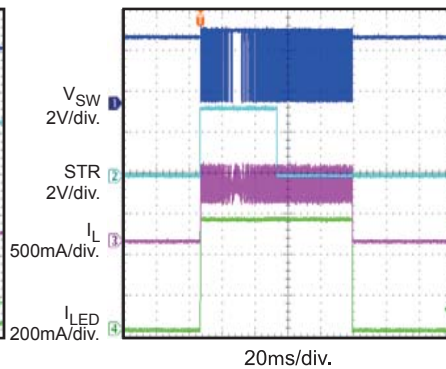

### Flash Mode

Software and Edge Sensitive Mode

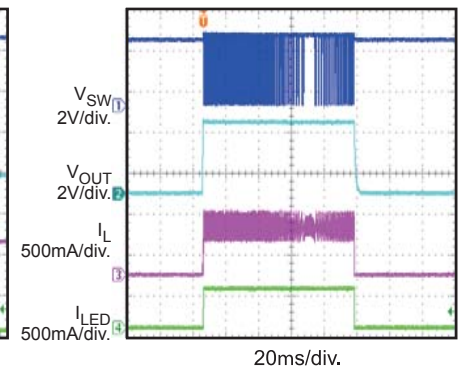

### LED Enable

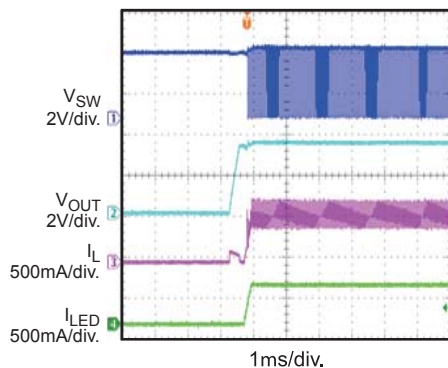



## TYPICAL PERFORMANCE CHARACTERISTICS (continued)

V<sub>IN</sub> = 3.3V, 1LED, FL\_TIM = 100ms, L = 1μH, T<sub>A</sub> = 25°C, unless otherwise noted.

### Torch to Flash Mode

I<sub>TOR</sub>=500mA, I<sub>FL</sub>=1A

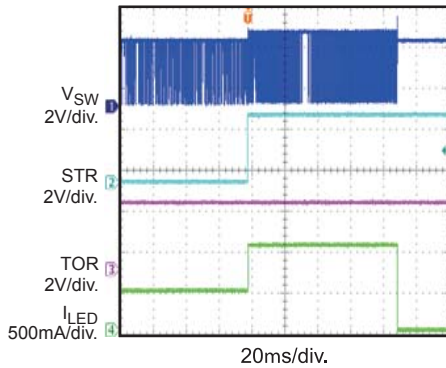

### Assist to Flash Mode

I<sub>TOR</sub>=500mA, I<sub>FL</sub>=1A

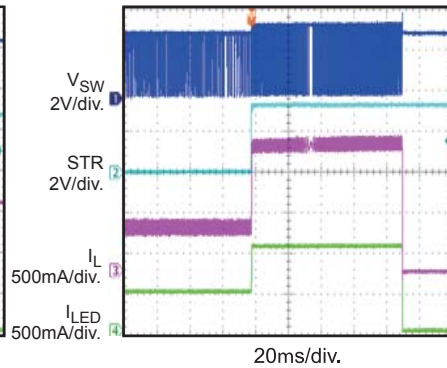

### Flash Mode

TX Pin with 3Hz PWM Input

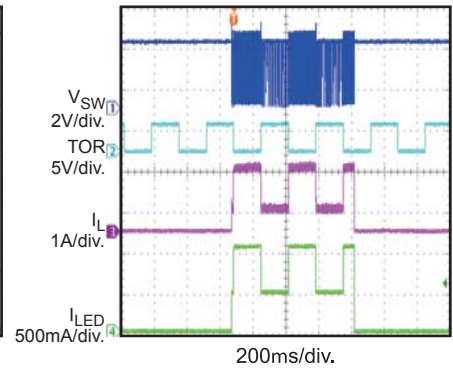

### LED-GND Short Protection

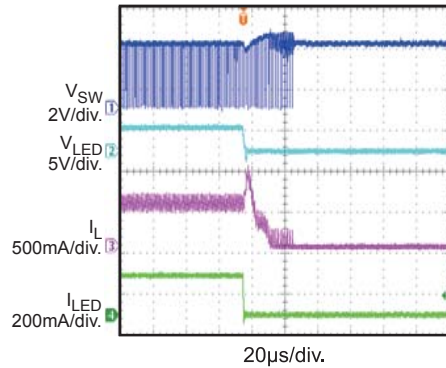

### LED Open Protection

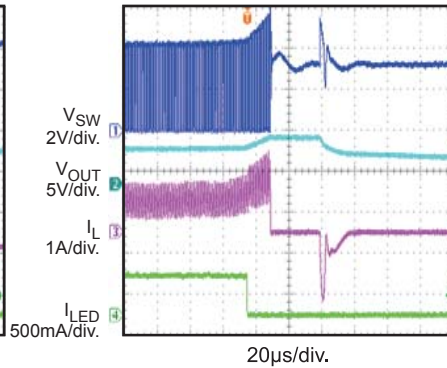

### V<sub>OUT</sub>-GND Pin Short Protection

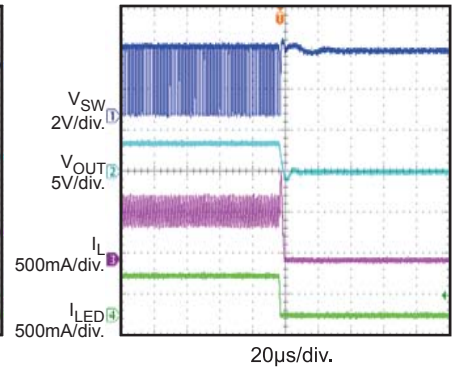

### Junction Over-Temperature Protection

In Flash Mode, T<sub>J</sub>>130°C

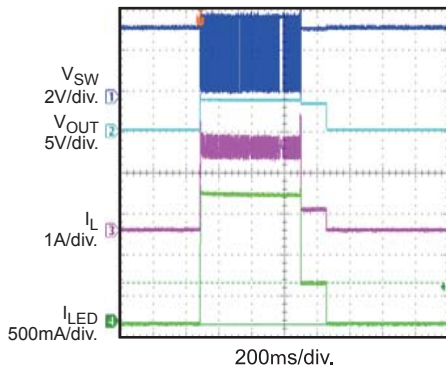

## PIN FUNCTIONS

Pin #	Name	Description
A1	OUT	<b>Boost converter output.</b>
A2	SW	<b>Boost converter switching node.</b>
A3	GND	<b>Ground.</b>
B1	LED	<b>Current source for LED.</b> Connect the anode of LED to LED.
B2	STR	<b>Strobe signal input</b> STR synchronizes the flash pulse to the image capture. If STR is floated, internally pull STR to low weakly.
B3	IN	<b>Input supply.</b> IN provides the power for the internal power and logic circuit. IN must be bypassed locally.
C1	TOR/TX	<b>Torch signal input or synchronization input signal for RF transmission signal.</b> If TOR/TX is floated, internally pull TOR/TX to low weakly.
C2	SDA	<b>I<sup>2</sup>C interface clock data input.</b>
C3	SCL	<b>I<sup>2</sup>C interface clock signal.</b>

### FUNCTIONAL BLOCK DIAGRAM

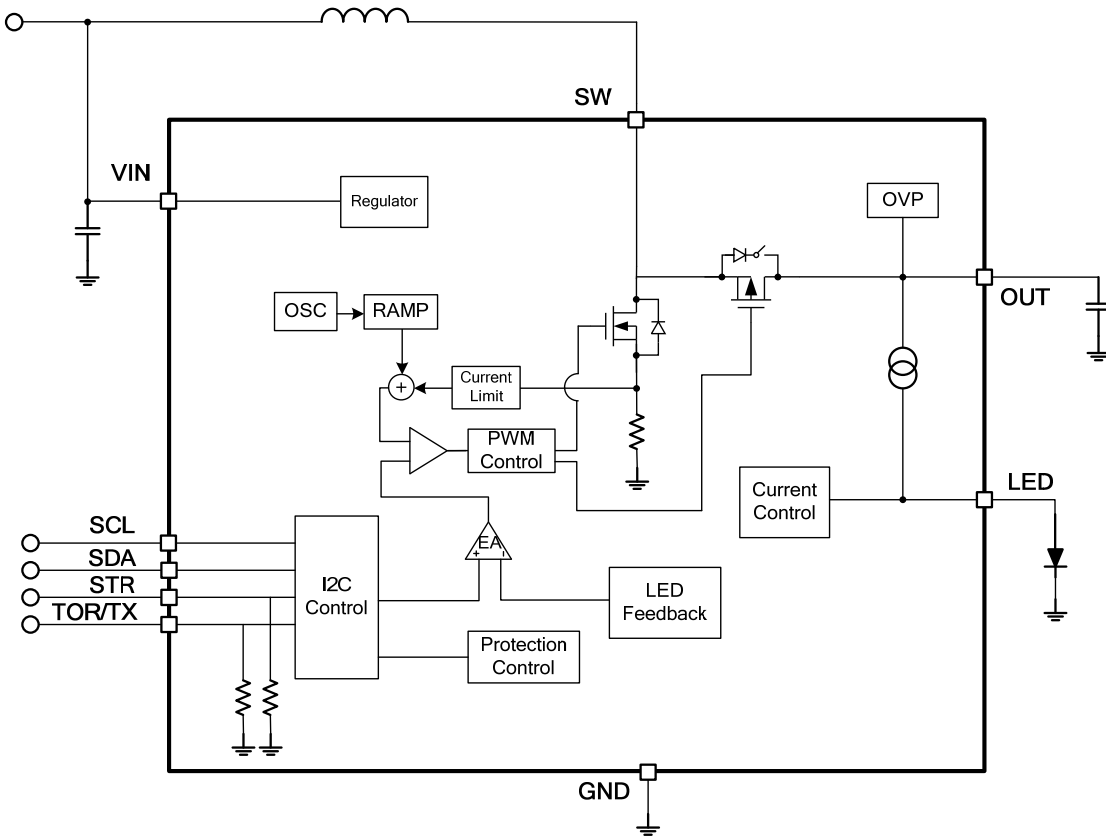

Figure 2: MP3331 Functional Block Diagram

## OPERATION

The MP3331 is a single-channel flash LED driver with an I<sup>2</sup>C interface for a camera flash that supports good image capture. It works in flash mode, assist mode, torch mode, indicator mode, and fixed 5V DC output mode.

### LED Driver Operation

The MP3331 uses PWM mode with peak current control to regulate the LED current. It works in a selectable 1M/2M/3M/4MHz switching frequency with a synchronous rectifier PMOS. When enabled, the synchronous PMOS

works as a 350mA current source to charge the output capacitor until V<sub>OUT</sub> rises above the 2.3V. The device will change to boost switching mode if the voltage across the current source is less than the target reference. If V<sub>IN</sub> is very close to V<sub>OUT</sub>, the IC works in boost switching mode and pass mode automatically to minimize the power loss. In pass mode, the synchronous PMOS is turned on completely. During the current start-up, the current ramps up smoothly step by step until the target setting current is reached.

**Table 1: Mode Configuration**

Configuration						Mode
TX/TOR	STR	LED_EN	STR_MOD	5V_MOD	LED_MOD	
High	X	1	0	X	00	Torch
X	X	1	X	X	10	Assist light
X	X	1	X	X	01	Indicator
X	High	1	1	X	11	Flash
X	X	1	0	X	11	Flash
High	High	1	1	X	00	Torch to flash
X	High	1	1	X	10	Assist to flash
X	X	X	X	1	X	5V

### Standby Mode

In default, if V<sub>IN</sub> is higher than UVLO, the device changes to standby mode. The I<sup>2</sup>C is active and is ready to communicate with the host. Table 1 shows all work modes for MP3331.

### Torch Mode

In standby mode, if TOR goes from low to high (TX/TOR = 1), the device switches to torch mode, and the current ramps up step by step after setting LED\_EN to 1. The current for LED is set through register I<sub>TOR</sub>. The ramping up slew rate is set by register TUP\_I. The current is disabled by pulling TOR to low or by setting LED\_EN bits to 0. By pulling TOR to low, LED\_EN and LED\_MOD bits will reset automatically to default if LED\_SD is 0 (see Figure 3).

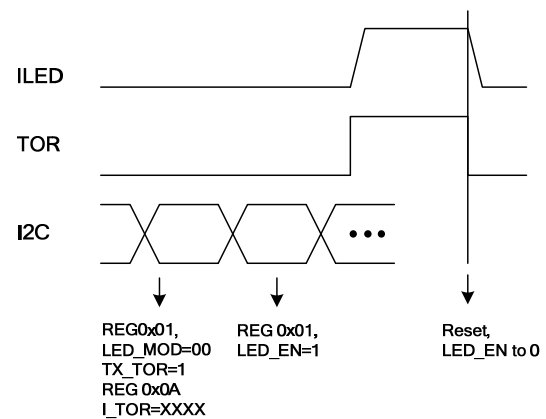

**Figure 3: Torch Mode**

### Assist Mode

To enter assist mode, set LED\_MOD register to 10 and LED\_EN to 1. The current ramps up to the target value, which is set by I<sub>TOR</sub>. The ramping up slew rate is set by register TUP\_I. The current is disabled by switching to standby mode or by setting LED\_EN bits to 0 (see Figure 4).

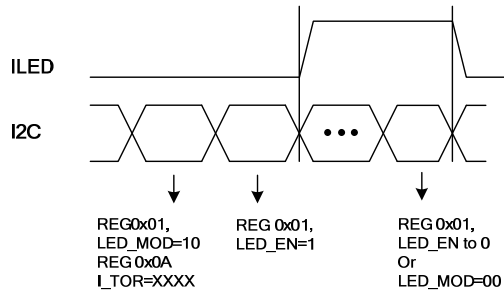
**Figure 4: Assist Mode**

### Indicator Mode

The device enters indicator mode, which provides a low current output when LED\_MOD is set to 01, and LED\_EN is set to 1. In this mode, the driver current sources the output current in 31.5kHz PWM mode. The current amplitude is set by I\_TOR while the duty cycle is set by the INDI\_PWM register. When disabled, switch to standby mode or set LED\_EN bits to 0 (see Figure 5).

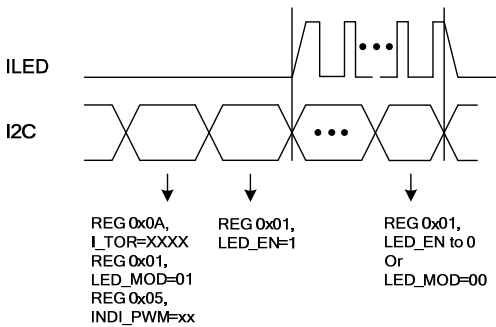
**Figure 5: Indicator Mode**

### Flash Mode

The device works in flash mode in the following ways:

#### 1. Hardware and level sensitive mode.

In this mode, STR\_MOD = 1, STR\_LV = 1, LED\_EN = 1, and LED\_MOD = 11. The flash current starts ramping up after STR goes high. The current is set by I\_FL, and the ramping up time is set by TUP\_I. The flash current ends when STR is pulled to low. If LED\_SD = 0, the LED\_MOD is reset to standby mode, and LED\_EN is set to 0 after the flash. If LED\_SD = 1, the LED\_MOD, and LED\_EN are not reset. If the flash timer set by FL\_TIM ends before STR goes low, the flash current terminates immediately.

LED\_MOD and LED\_EN are reset to the default value, and the time-out fault bit FT\_TO is set to 1 and is not cleared until read back or input power reset (see Figure 6).

Flash ends when pulling STR pin to low.

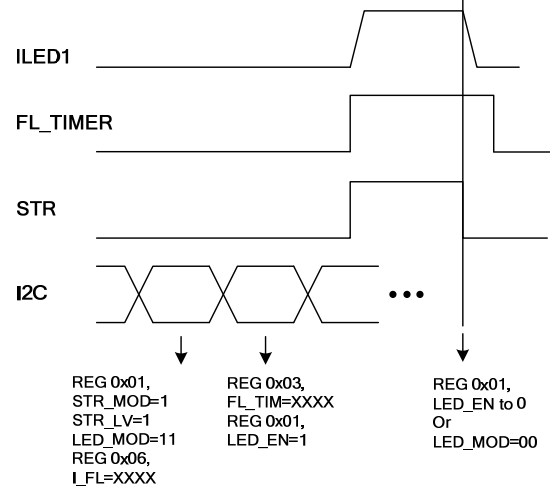

Flash ends when time out is over.

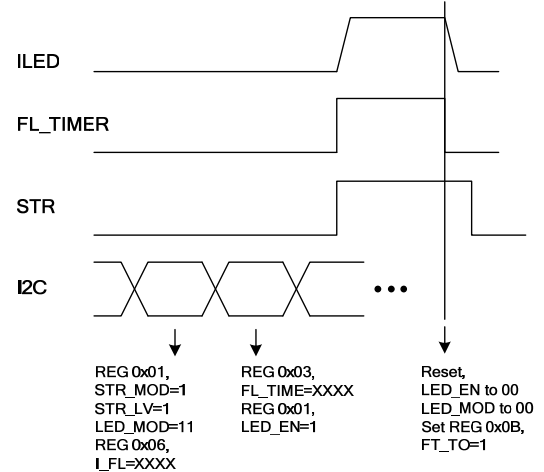
**Figure 6: Hardware and Level Sensitive Mode**

#### 2. Hardware and edge sensitive mode.

In this mode, STR\_MOD = 1, STR\_LV = 0, LED\_EN = 1, and LED\_MOD = 11. The flash current starts ramping up after STR goes high. The current is set by I\_FL, and the ramping up time is set by TUP\_I. The flash current ends when the flash timer set by FL\_TIM ends. If LED\_SD = 0, the LED\_MOD is reset to standby mode, and LED\_EN is set to 0 after the flash. If LED\_SD = 1, the LED\_MOD, and LED\_EN are not reset (see Figure 7).

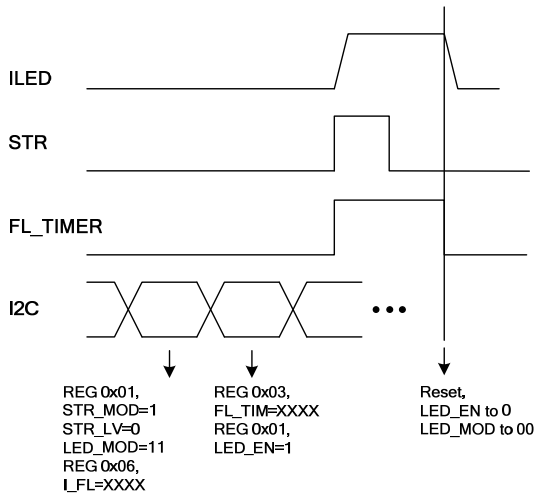
**Figure 7: Hardware and Edge Sensitive Mode**

### 3. Software and edge sensitive mode

In this mode, STR\_MOD = 0, LED\_EN = 1, and LED\_MOD = 11. The current is set by I\_FL, and the ramping up time is set by TUP\_I. The flash current ends when the flash timer set by FL\_TIM ends. If LED\_SD = 0, the LED\_MOD is reset to standby mode, and LED\_EN is set to 0 after the flash. If LED\_SD = 1, the LED\_MOD, and LED\_EN are not reset (see Figure 8).

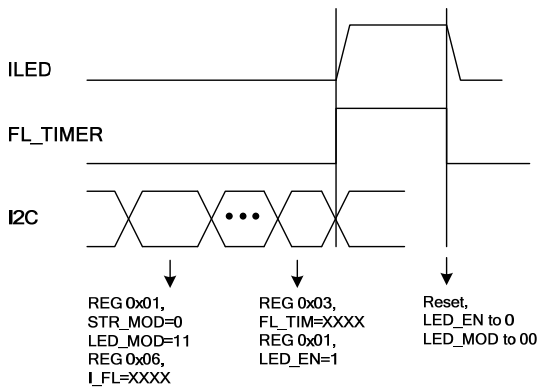
**Figure 8: Software and Edge Sensitive Mode**

### Torch Mode to Flash Mode

During torch mode, the device can change to flash mode from torch mode directly when STR goes from low to high (if STR\_MOD = 1). After the flash, the operation is the same as described in the “Flash Mode” section (see Figure 9).

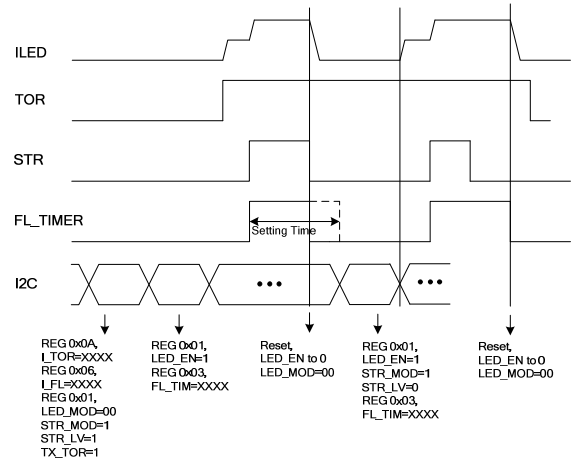
**Figure 9: Torch Mode to Flash Mode**

### Assist Mode to Flash Mode

During assist-light mode, the device can change to flash mode from assist-light mode directly when STR goes from low to high (if STR\_MOD = 1). After the flash, the operation is the same as described in the “Flash Mode” section (see Figure 10).

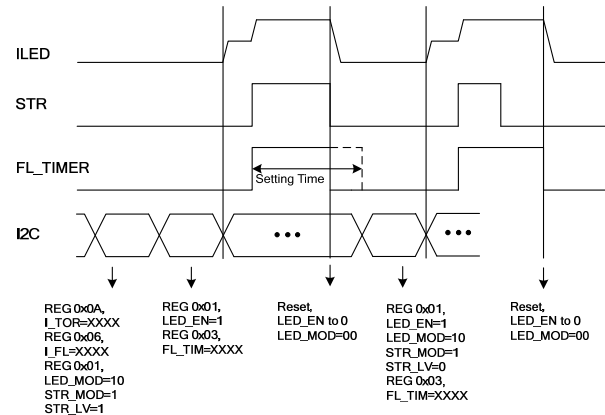
**Figure 10: Assist Mode to Flash Mode**

### 5V DC Output Mode

If 5V\_MOD is set to 1, the device works in a fixed 5V DC output mode, and the control loop is taken over by the voltage loop. Note that the LED current sources can still output current if the mode conditions are met (as described above). Care must be taken to ensure thermal temperatures are ok because the 5V powers the LED directly. To avoid this, it is recommended to set LED\_EN to 0 during the 5V DC mode (see Figure 11).

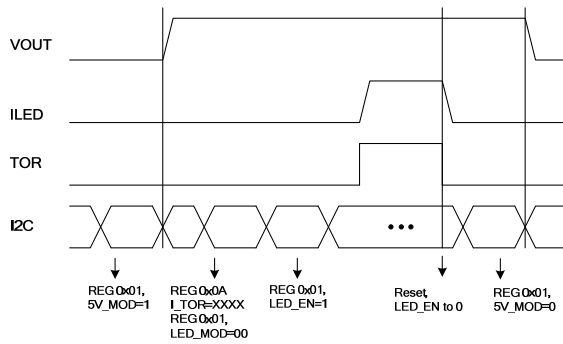
**Figure 11: 5V DC Mode**

### Switching Frequency Setting

The switching frequency is selected by SW\_FS bits. 1M/2M/3M/4MHz are available to optimize efficiency.

### Switching Frequency Foldback

In default 4MHz switching mode, if the voltage across the current source is larger than the value set by the register bits VTH\_PAS, the IC switches to 1MHz mode to improve efficiency and EMI. In 1MHz mode, the switching frequency can be stretched down according to the load condition with FS\_SD =0. The IC goes into pass mode (which turns on the synchronous PMOS fully) if the input voltage is high enough.

### Current Reduction

When the MP3331 works in flash mode, output current reduction may occur due to the following conditions:

#### 1. TX is high.

During flash mode, if TOR/TX goes from low to high, the flash current drops to the current set by I\_TX in less than 5μs and sets the FT\_TX bit to 1. If TX goes low, the current ramps up to the flash current again (see Figure 12).

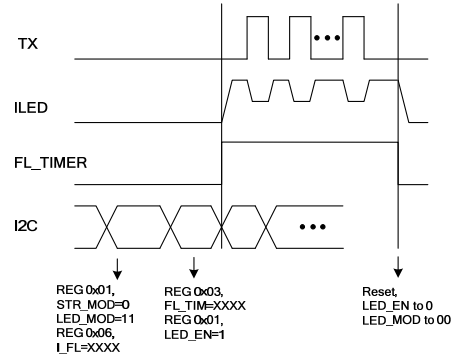
**Figure 12: Flash Mode when TX is Active**

#### 2. Low battery voltage threshold is triggered.

During a flash pulse, if the battery voltage drops below the threshold set by VBL\_RUN, the current reduces step-by-step with a 2μs/step until the battery voltage rises up to the specific low battery voltage threshold. Actual current in the IFL\_ACT register can be read back. The minimum current caused by the current reduction in IFL\_MIN can be read back after the flash.

### Low Battery Voltage Protection

The device provides low battery voltage protection in flash mode in the following ways:

1. Before the flash, if the input voltage is lower than the threshold set by VBL\_RUN, the device remains disabled (if VBL\_SD = 1 and sets the fault bit FT\_VBATL to 1). If VBL\_SD = 0, the device ramps to the current set by I\_TX and sets the fault bit FT\_VBATL to 1. The fault bit is cleared after read back or the input power resets.

2. During flash start-up, if the input voltage is lower than the threshold set by VBL\_RUN, the current stops ramping. The fault bit FT\_VBATL is set. During the flash pulse, if the input voltage is lower than the threshold set by VBL\_RUN, the current ramps down step-by-step. The fault bit is set until read back or the input power resets. After the flash, the minimum current caused by the current reduction is read back through the IFL\_MIN register. The IFL\_MIN value holds until the next flash occurs or the power resets. The actual current is read back through IFL\_ACT during flash time. This

function tells the device how much flash current can be drawn from the battery for the next flash. Thus, it is possible to do a pre-flash function and provide continuous stable flash current according to IFL\_MIN information (see Figure 13).

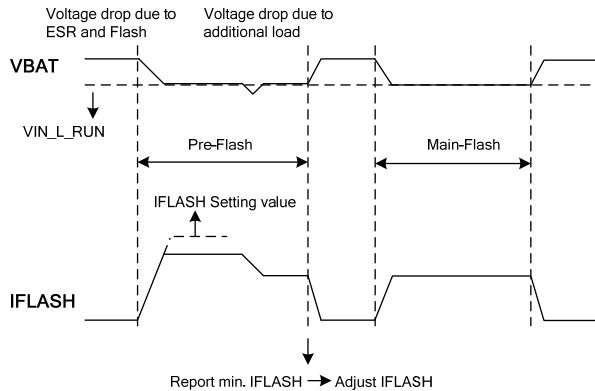

**Figure 13: Pre-Flash Operation**

### VOUT-GND Short Protection

If  $V_{OUT} < V_{IN} - 1V$ , the device stops switching and disconnects the synchronous PMOS to avoid drawing a very large current from the battery. Once the device stops switching, set the FT\_VOSC bit to 1 and reset the mode setting. The fault bit remains until read back or power reset.

### LED-GND Short Protection

If  $V_{LED} < 1V$  &  $I_{LED} > 25mA$ , the IC marks off the current source and resets the mode setting bits. Then the fault bit FT\_LEDSC is set. The fault bit FT\_LEDSC is 1 until read back or power reset.

### LED Open Protection

If  $V_{OUT} - V_{LED} < 90mV$  &  $V_{OUT} > 5.5V$ , the IC stops switching and resets the mode setting bits. Then the fault bits FT\_OVP and FT\_LEDOP are set. The fault bits FT\_OVP and FT\_LEDOP are 1 until read back or power reset.

### Output Over-Voltage Protection

If  $V_{OUT} > 5.5V$ , the device stops switching and resumes normal operation until  $V_{OUT}$  drops below 5.2V. The fault bit FT\_OVP is 1 until read back or power reset.

### Junction Over-Temperature Protection

If  $T_j > 130^{\circ}C$ , the flash current drops to the current set by  $I_{TX}$  (if LED\_OTAD = 1). The fault bit FT\_OTP is set. If  $T_j > 150^{\circ}C$ , the device stops switching and resets the mode setting. The fault bit FT\_OTP has to be cleared to 0 by read back or power reset before the IC will re-start.

### Time-Out Protection

If the device works in flash mode with hardware and level sensitive enabled, the time-out protection triggers when the STR high-level pulse is longer than the timer set by FL\_TIM. The device stops switching and resets the mode setting. The fault bit is 1 until read back or power reset before the IC re-starts.

### UVLO Protection

If the VIN drops below the UVLO threshold, the device stops, and all the registers are reset to default.

### I<sup>2</sup>C Interface Register Description

#### I<sup>2</sup>C Chip Address

After the start condition, the I<sup>2</sup>C compatible master sends a 7-bit address followed by an eighth read (read: 1) or write (write: 0) bit. The following bit indicates the register address to/from which the data will be written/read (see Figure 14 and the Tables below).

							LSB
1	1	0	0	1	1	1	R/W

**Figure 14: I<sup>2</sup>C Compatible Device Address**



**Register Mapping:**

Add	D7	D6	D5	D4	D3	D2	D1	D0
00H	DEV_ID4	DEV_ID3	DEV_ID2	DEV_ID1	DEV_ID0	REV_ID2	REV_ID1	REV_ID0
01H	STR_LV	STR_MOD	STR_POL	LED_EN	TX_TOR	LED_MOD1	LED_MOD0	5V_MOD
02H	NA	NA	NA	IL_PEAK1	IL_PEAK0	FS_SD	NA	NA
03H	FL_TIM3	FL_TIM2	FL_TIM1	FL_TIM0	LED_SD	NA	SW_FS1	SW_FS0
04H	VBL_RUN2	VBL_RUN1	VBL_RUN0	VBL_SD	NA	NA	NA	NA
05H	LED_OTAD	TUP_I2	TUP_I1	TUP_I0	VTH_PAS1	VTH_PAS0	INDI_PWM1	INDI_PWM0
06H	NA	NA	I_FL5	I_FL4	I_FL3	I_FL2	I_FL1	I_FL0
07H	NA	NA	I_TX5	I_TX4	I_TX3	I_TX2	I_TX1	I_TX0
08H	NA	NA	IFL_ACT5	IFL_ACT4	IFL_ACT3	IFL_ACT2	IFL_ACT1	IFL_ACT0
09H	NA	NA	IFL_MIN5	IFL_MIN4	IFL_MIN3	IFL_MIN2	IFL_MIN1	IFL_MIN0
0AH	NA	NA	I_TOR5	I_TOR4	I_TOR3	I_TOR2	I_TOR1	I_TOR0
0BH	FT_VBATL	FT_OVP	FT_VOOSC	FT_LEDSC	FT_OTP	FT_TO	FT_TX	NA
0CH	NA	NA	NA	NA	NA	NA	NA	FT_LEDOP

**Table 1: Chip ID Register**

Addr: 0x00				
Bit	Bit Name	Access	Default	Description
2:0	REV_ID	R	000	Revision ID
7:3	DEV_ID	R	00011	Device ID

**Table 2: Mode Setting Register**

Addr: 0x01				
Bit	Bit Name	Access	Default	Description
7	STR_LV	RW	1	Flash mode trigger mode with STR signal. 0 = edge sensitive; 1 = level sensitive.
6	STR_MOD	RW	1	STR enable bit. 0 = software enable; 1 = hardware enable.
5	STR_POL	RW	1	STR signal input active polarity. 0 = active low; 1 = active high.
4	LED_EN	RW	0	LED current source enable bit. 0 = LED current sink disable; 1 = enable
3	TX_TOR	RW	0	TX mode or torch mode selection bit; 0 indicates TX/TOR used for TX signal; 1 indicates TX/TOR used for torch signal. In flash mode, TX/TOR is forced to be used as a TX signal pin regardless of what this bit is.
2:1	LED_MOD	RW	00	Device mode setting bits. 00 = standby/torch mode; 01 = indicator mode; 10 = assist light mode; 11 = flash mode.
0	5V_MOD	RW	0	5V DC output enable bit. 0 = disable; 1 = enable.

**Table 3: Peak Current Setting Register**

Addr: 0x02				
Bit	Bit Name	Access	Default	Description
7:5	NA	RW	000	Reserved.
4:3	IL_PEAK	RW	01	Inductor current limit setting bits. 00 = 1.9A, 01 = 2.8A, 10 = 3.6A, 11 = 4.2A
2	FS_SD	RW	0	Disable switching frequency stretching down from 1MHz if VIN voltage is close to VOUT voltage. 0 = Enable Fs stretching down function. 1 = Disable Fs stretching down function.
0:1	NA	RW	NA	Reserved.

**Table 4: Flash Timer Setting Register**

<b>Addr: 0x03</b>				
<b>Bit</b>	<b>Bit Name</b>	<b>Access</b>	<b>Default</b>	<b>Description</b>
7:4	FL_TIM	RW	0001	Flash timer setting bits. 50ms to 800ms, 50ms/step. 0000 = 50ms; 0001 = 100ms; ...; 1111 = 800ms.
3	LED_SD	RW	0	LED_MOD and LED_EN resetting control bit. 0 = reset LED_MOD and LED_EN to default value after flash or torch. 1 = no reset.
2	NA	RW	0	Reserved.
1:0	SW_FS	RW	00	Switching frequency setting bits. 00 = 4MHz; 01 = 3MHz; 10 = 2MHz; 11 = 1MHz.

**Table 5: Low Battery Voltage Setting Register**

<b>Addr: 0x04</b>				
<b>Bit</b>	<b>Bit Name</b>	<b>Access</b>	<b>Default</b>	<b>Description</b>
7:5	VBL_RUN	RW	111	Low battery voltage setting bits. If VIN drops below this voltage during start-up, the current ramping stops. If VIN drops below this voltage during the flash current pulse, the current is decreased until VIN is higher than its threshold. It works only in flash mode. 000 = 3V; 001 = 3.1V; ...110 = 3.6V; 111 = disabled; 0.1V per step.
4	VBL_SD	RW	1	Device disabled or reduce the flash current selection bit when VIN is less than the threshold set by VBL_RUN before the flash. 1 = device disabled; 0 = Enable and the current ramps up to the current set by I_TX.
3:0	NA	RW	NA	NA

**Table 6: Indicator Register**

Addr: 0x05				
Bit	Bit Name	Access	Default	Description
7	LED_OTAD	RW	0	Adaptive thermal flash current control bit. 1 = current reduced to the current set by I_TX when T <sub>j</sub> >130°C; 0 = disable when T <sub>j</sub> >150°C.
6:4	TUP_I	RW	001	Current ramp-up time per step. 000 = 8μs; 001 = 16μs; ...111 = 64μs/step.
3:2	VTH_PAS	RW	01	Defines the threshold when F <sub>s</sub> drops to 1MHz or switches to pass mode from boost mode. 00 = 300mV, 01 = 450mV, 10 = 600mV, 11 = 750mV.
1:0	INDI_PWM	RW	00	PWM duty cycle of 31.5kHz in indicator mode. 00 = 2/16; 01 = 3/16; 10 = 4/16; 11 = 5/16.

**Table 7: LED Flash Current Setting Register**

Addr: 0x06				
Bit	Bit Name	Access	Default	Description
7:6	NA	RW	NA	Reserved.
5:0	I_FL	RW	010000	LED flash current setting bits. 0 to 2000mA, 31.7mA/step. 000000 = 0mA; 000001 = 31.7mA...111111 = 2000mA. (Default 010101 = 508mA)

**Table 8: TX Current Setting Register**

Addr: 0x07				
Bit	Bit Name	Access	Default	Description
7:6	NA	RW	NA	Reserved.
5:0	I_TX	RW	010000	Defines the flash current in flash mode if TX is high. 0 to 2000mA, 31.7mA/step. 000000 = 0mA; 000001 = 31.7mA...111111 = 2000mA. (Default 010000 = 508mA).

**Table 9: Actual Flash LED Current Register**

Addr: 0x08				
Bit	Bit Name	Access	Default	Description
7:6	NA	R	NA	Reserved.
5:0	IFL_ACT	R	000000	The actual flash current in flash mode. It can be read only during flash. 0 to 2000mA, 31.7mA/step. 000000 = 0mA; 000001= 31.7mA ...111111 = 2000mA.

**Table 10: Minimum Flash LED Current Register**

Addr: 0x09				
Bit	Bit Name	Access	Default	Description
7:6	NA	R	NA	Reserved.
5:0	IFL_MIN	R	000000	The minimum flash current caused by low battery voltage current reduction in flash mode. 0 to 2000mA, 31.7mA/step. 000000 = 0mA; 000001= 31.7mA ... 111111 = 2000mA.

**Table 11: LED Torch Current Setting Register**

Addr: 0x0A				
Bit	Bit Name	Access	Default	Description
7:6	NA	R	NA	Reserved.
5:0	I_TOR	RW	001000	LED torch current setting bits. 0 to 508mA, 31.7mA/step. 000000 = 0mA, 000001= 31.7mA ...010000 = 508mA. (Default 001000 = 254mA)

**Table 12: Fault Indication Register**

<b>Addr: 0x0B</b>				
<b>Bit</b>	<b>Bit Name</b>	<b>Access</b>	<b>Default</b>	<b>Description</b>
7	FT_VBATL	R	0	Low battery voltage fault bit. 0 = no fault.            1 = fault.
6	FT_OVP	R	0	Output over voltage fault bit. 0 = no fault.            1 = fault.
5	FT_VOOSC	R	0	VOUT-GND short fault bit. 0 = no fault.            1 = fault.
4	FT_LEDSC	R	0	LED short fault bit. 0 = no fault            1 = fault.
3	FT_OTP	R	0	Junction over-temperature fault bit. 0 = no fault            1 = fault.
2	FT_TO	R	0	Flash time out fault bit. 0 = no fault.            1 = fault.
1	FT_TX	R	0	TX fault bit. 0 = no fault.            1 = fault.
0	NA	R	NA	NA

**Table 13: Fault Indication Register**

<b>Addr: 0x0C</b>				
<b>Bit</b>	<b>Bit Name</b>	<b>Access</b>	<b>Default</b>	<b>Description</b>
7:2	NA	R	NA	Reserved.
1	NA	R	NA	Reserved.
0	FT_LEDOP	R	0	LED open fault bit. 0 = no fault;            1 = fault.

## APPLICATION INFORMATION

### Selecting the Input Capacitor

The input capacitor reduces the surge current drawn from the input supply and the switching noise from the device. The input capacitor impedance at the switching frequency should be less than the input source impedance to prevent the high-frequency switching current from passing through to the input. Use ceramic capacitors with X5R or X7R dielectrics for their low ESR and small temperature coefficients. A higher value capacitor helps reduce the input voltage ripple and noise. For most applications, a 10µF ceramic capacitor will suffice.

### Selecting the Inductor

The converter requires an inductor to supply a higher output voltage while being driven by the input voltage. A larger value inductor results in less ripple current, resulting in lower peak inductor current and reducing stress on the internal N-channel MOSFET. However, the larger value inductor has a larger physical size, a higher series resistance, and a lower saturation current.

Choose an inductor that does not saturate under the worst-case load conditions. Select the minimum inductor value to ensure that the boost converter works in continuous conduction mode (CCM) with high efficiency and good EMI performance.

Calculate the required inductance value using Equation (1) and Equation (2):

$$L \geq \frac{\eta \times V_{OUT} \times D \times (1-D)^2}{2 \times f_{SW} \times I_{LOAD}} \quad (1)$$

$$D = 1 - \frac{V_{IN}}{V_{OUT}} \quad (2)$$

Where  $V_{IN}$  and  $V_{OUT}$  are the input and output voltages,  $f_{SW}$  is the switching frequency;  $I_{LOAD}$  is the LED load current, and  $\eta$  is the efficiency.

The switching current is used for the peak current mode control. In order to avoid reaching the current limit, the worst-case inductor peak current should be less than 80% of the current-limit ( $I_{LIM}$ ). For most applications, 0.47µH~2µH inductor will suffice.

### Selecting the Output Capacitor

The output capacitor keeps the output voltage ripple small and ensures feedback loop stability. The output capacitor impedance must be low at the switching frequency. Ceramic capacitors with X7R dielectrics are recommended for their low ESR characteristics. Please note that ceramic capacitance is dependent on the voltage rating; a DC bias voltage and the value can lose as much as 50% of its capacitance at its rated voltage rating. Please leave a large enough voltage rating margin when selecting the component. In addition, too low a capacitance value will cause loop instability. For most applications, a 10µF ceramic capacitor will suffice.

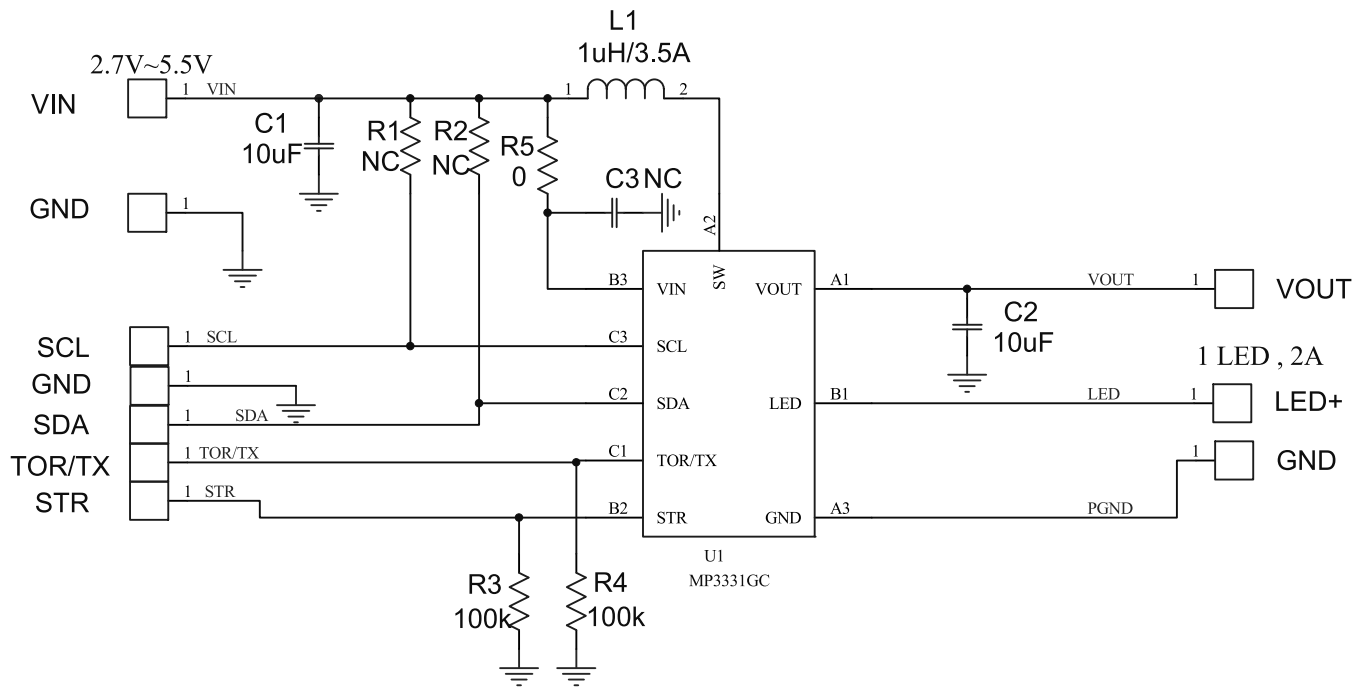
**TYPICAL APPLICATION CIRCUITS**

**Figure 15: Typical Application Circuit**

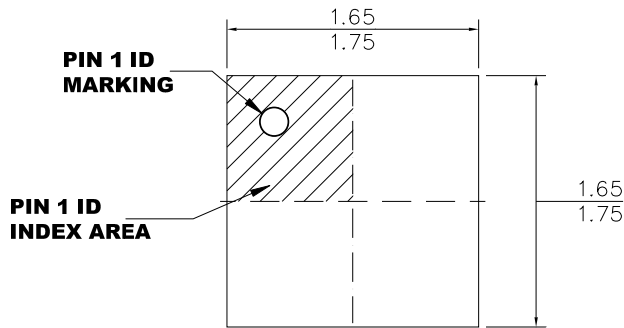

## PACKAGE INFORMATION

### WLCSP-9 (1.7mm x 1.7mm)



**TOP VIEW**

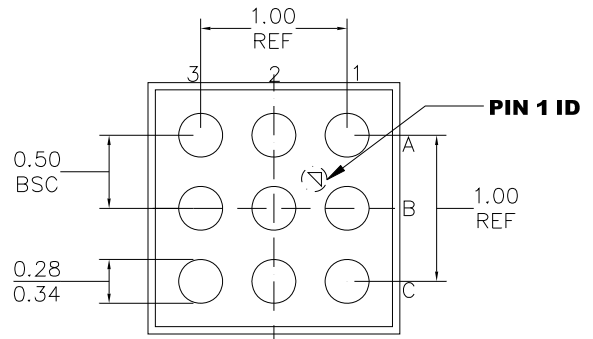

**BOTTOM VIEW**

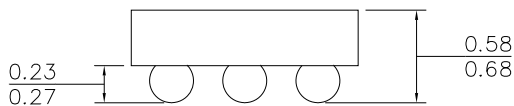

**SIDE VIEW**

**NOTE:**

- 1) ALL DIMENSIONS ARE IN MILLIMETERS.
- 2) BALL COPLANARITY SHALL BE 0.05 MILLIMETER MAX.
- 3) JEDEC REFERENCE IS MO-211.
- 4) DRAWING IS NOT TO SCALE.

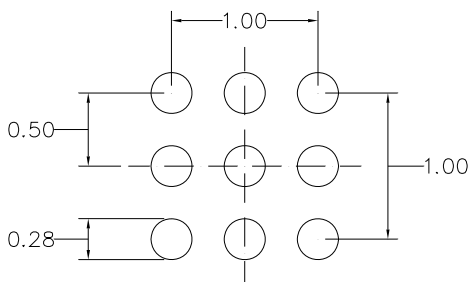

**RECOMMENDED LAND PATTERN**

**NOTICE:** The information in this document is subject to change without notice. Users should warrant and guarantee that third party Intellectual Property rights are not infringed upon when integrating MPS products into any application. MPS will not assume any legal responsibility for any said applications.



Компания «ЭлектроПласт» предлагает заключение долгосрочных отношений при поставках импортных электронных компонентов на взаимовыгодных условиях!

Наши преимущества:

- Оперативные поставки широкого спектра электронных компонентов отечественного и импортного производства напрямую от производителей и с крупнейших мировых складов;
- Поставка более 17-ти миллионов наименований электронных компонентов;
- Поставка сложных, дефицитных, либо снятых с производства позиций;
- Оперативные сроки поставки под заказ (от 5 рабочих дней);
- Экспресс доставка в любую точку России;
- Техническая поддержка проекта, помощь в подборе аналогов, поставка прототипов;
- Система менеджмента качества сертифицирована по Международному стандарту ISO 9001;
- Лицензия ФСБ на осуществление работ с использованием сведений, составляющих государственную тайну;
- Поставка специализированных компонентов (Xilinx, Altera, Analog Devices, Intersil, Interpoint, Microsemi, Aeroflex, Peregrine, Syfer, Eurofarad, Texas Instrument, Miteq, Cobham, E2V, MA-COM, Hittite, Mini-Circuits, General Dynamics и др.);

Помимо этого, одним из направлений компании «ЭлектроПласт» является направление «Источники питания». Мы предлагаем Вам помощь Конструкторского отдела:

- Подбор оптимального решения, техническое обоснование при выборе компонента;
- Подбор аналогов;
- Консультации по применению компонента;
- Поставка образцов и прототипов;
- Техническая поддержка проекта;
- Защита от снятия компонента с производства.



#### Как с нами связаться

**Телефон:** 8 (812) 309 58 32 (многоканальный)

**Факс:** 8 (812) 320-02-42

**Электронная почта:** [org@eplast1.ru](mailto:org@eplast1.ru)

**Адрес:** 198099, г. Санкт-Петербург, ул. Калинина, дом 2, корпус 4, литера А.