

rev	ecn no	dr	date
C	V03-0663	TAB	2003-06-12
D	V06-0052	VS	2005-10-14
E	V06-0558	LP	2006-06-12
F	V07-0440	LP	2007-07-05
G	V08-0198	HTB	2008-04-28

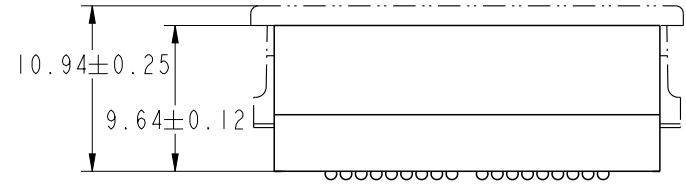
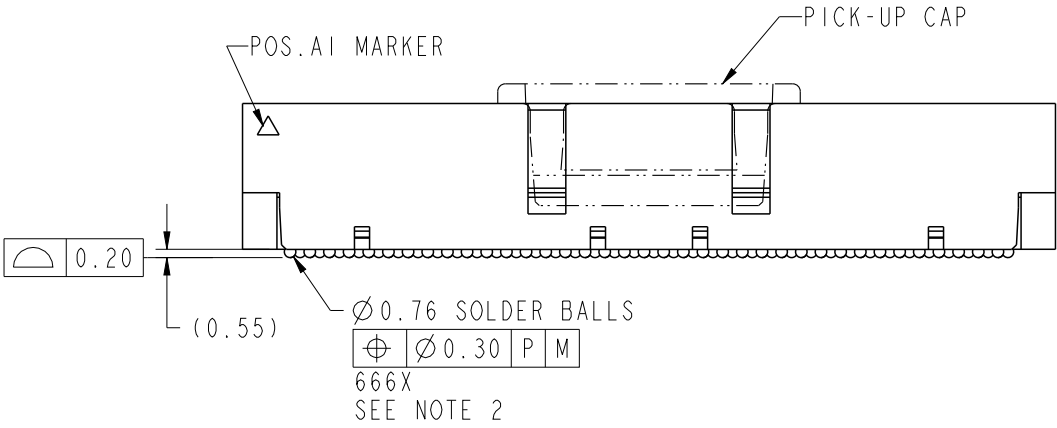
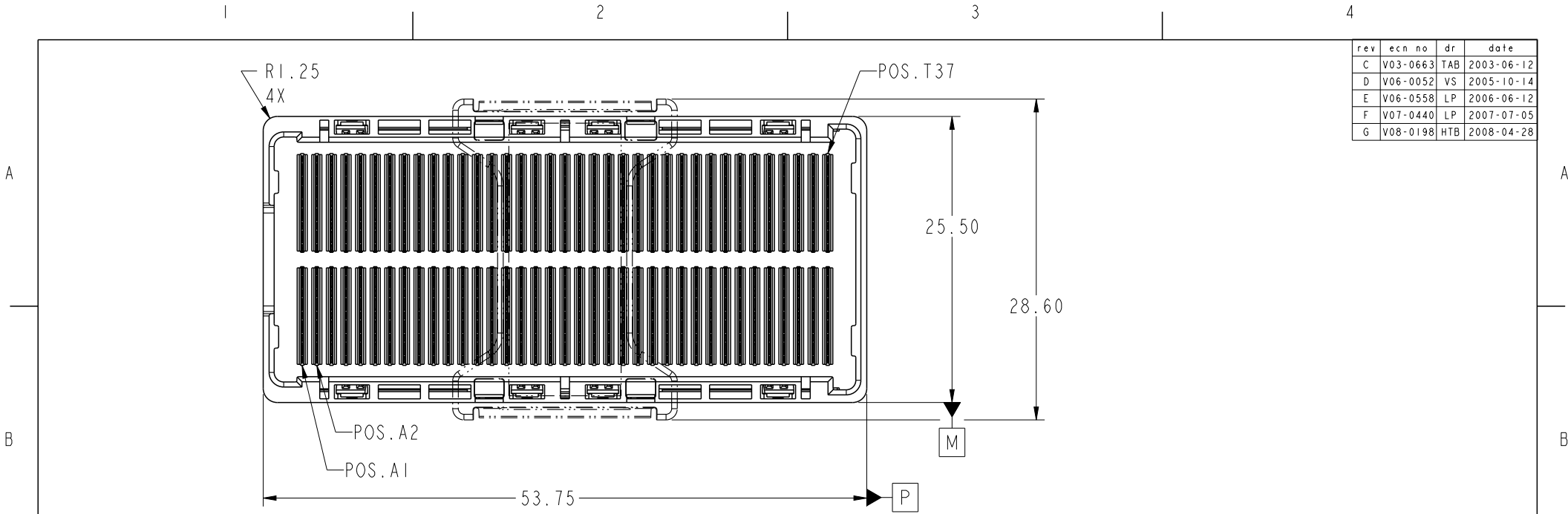

Copyright FCI.

spec ref	-	dr	Bill Lin	2010/02/02	projection 	mm 	size	A4	scale	1:1
tolerance std	TOLERANCES UNLESS OTHERWISE SPECIFIED	eng	Nickor Zuo	2011/06/09			ecn no	ELX-DG-003943-1		
-	-	chr	Alex Cao	2011/06/24			product family	GIG-Array		
surface	3.2	appr	Pei-Ming Zheng	2011/06/27	rel level	Released				
ASME Y14.5	linear	0.X	±0.30	 www.fci.com	title	GIG-Array		dwg no 55720	rev J	
		0.XX	±0.10		10mm PLUG ASSY. 296 SIG. POS.					
		0.XXX	±0.05							
	angular	0°	±2°	cat. no.	-	Product - Customer Drw	sheet 1 of 5			

ProjE File - REV C - 2009-06-09



Copyright FCI.

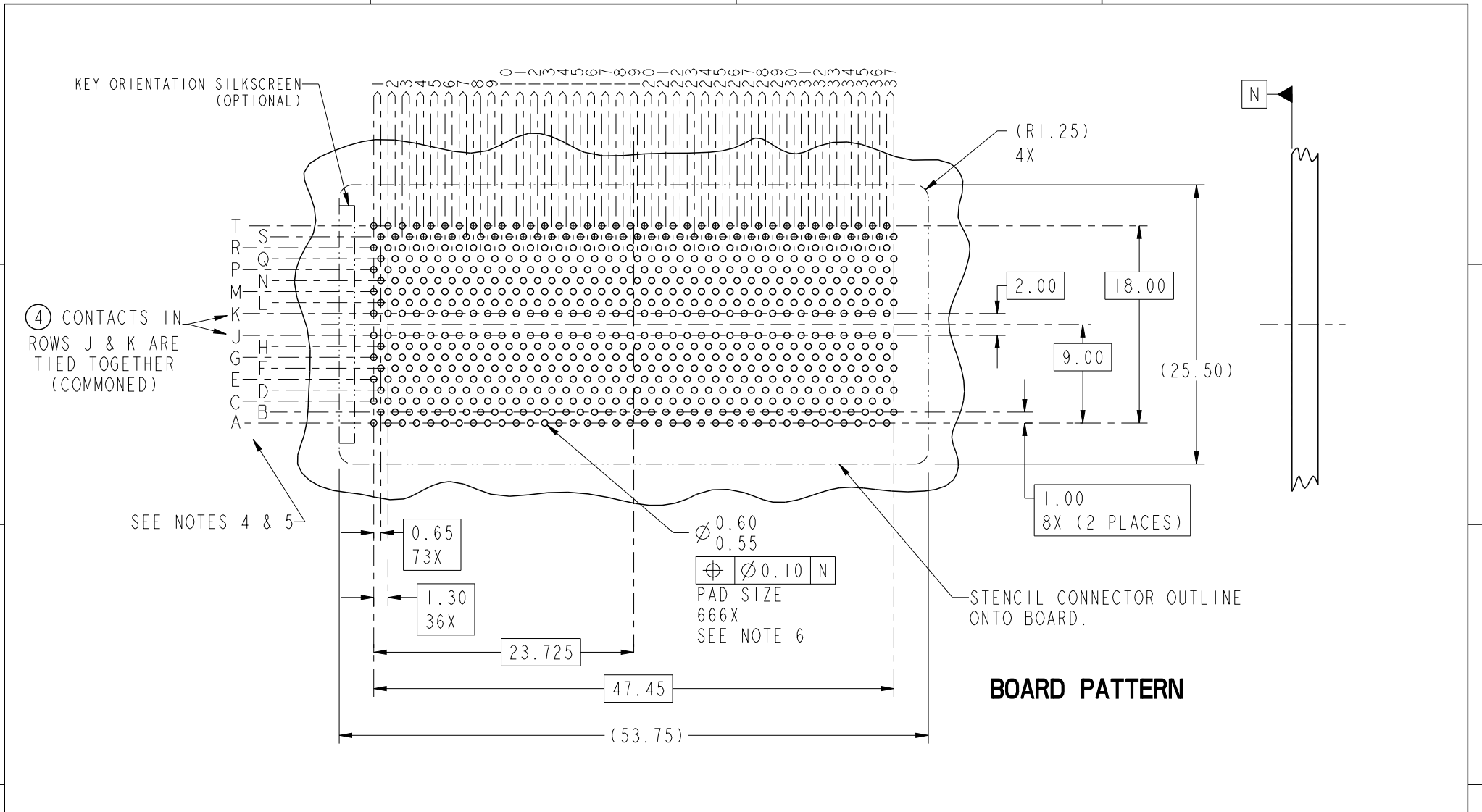

BOARD PATTERN

spec ref		-		dr	Bill Lin	2010/02/02	projection	mm	size	A4	scale	1:1		
tolerance std		TOLERANCES UNLESS OTHERWISE SPECIFIED		eng	Nickor Zuo	2011/06/09					ecn no		ELX-DG-003943-1	
-		-		chr	Alex Cao	2011/06/24	product family				GIG-Array	rel level		Released
-		-		appr	Pei-Ming Zheng	2011/06/27	product family		GIG-Array	rel level		Released		
surface	3.2	linear	0.X	±0.30		title		GIG-Array		dwg no	55720		rev	J
			0.XX	±0.10		10mm PLUG ASSY. 296 SIG. POS.								
ASME Y14.5		angular	0°	±2°	www.fci.com	cat. no.	-		Product - Customer Drw		sheet 2 of 5			

PrdE File - REV C - 2009-06-09

A

B

C

D

A

B

C

D

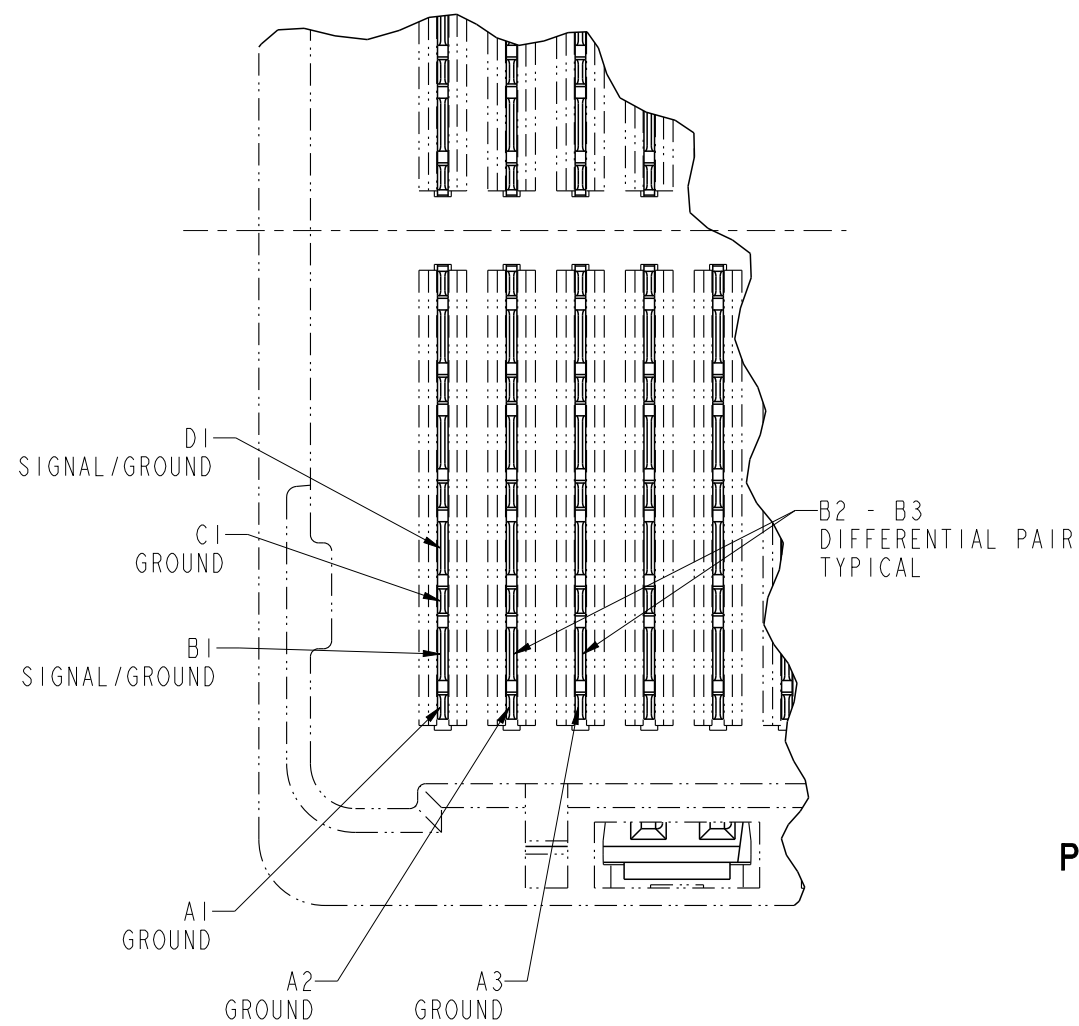

PLUG INTERFACE DESCRIPTION



Copyright FCI.

spec ref -		dr Bill Lin 2010/02/02		projection 	mm 	size A4	scale 1:1
tolerance std -		eng Nickor Zuo 2011/06/09				ecn no ELX-DG-003943-1	
-		chr Alex Cao 2011/06/24				rel level Released	
-		appr Pei-Ming Zheng 2011/06/27		product family GIG-Array		rev J	
surface 3.2 ASME Y14.5	linear	0.X	±0.30	 title GIG-Array 10mm PLUG ASSY. 296 SIG. POS.	dwg no 55720	sheet 3 of 5	
		0.XX	±0.10			Product - Customer Drw	
	angular	0°	±2°	cat. no. -	STATUS:Released		Printed: Jun 27, 2011

ProE File - REV C - 2009-06-09

**FLAT AREA
PICK-UP CAP**

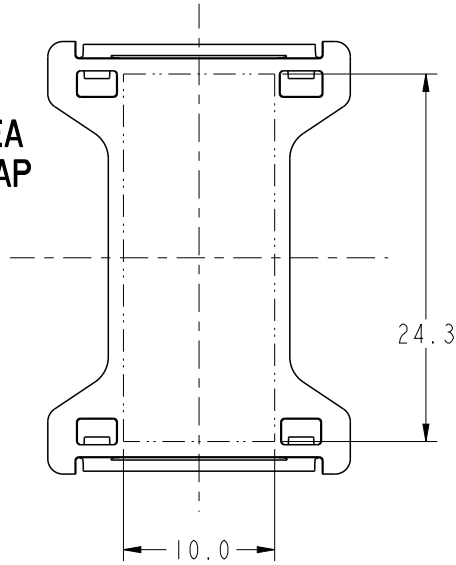

END VIEW OF MATED CONNECTORS

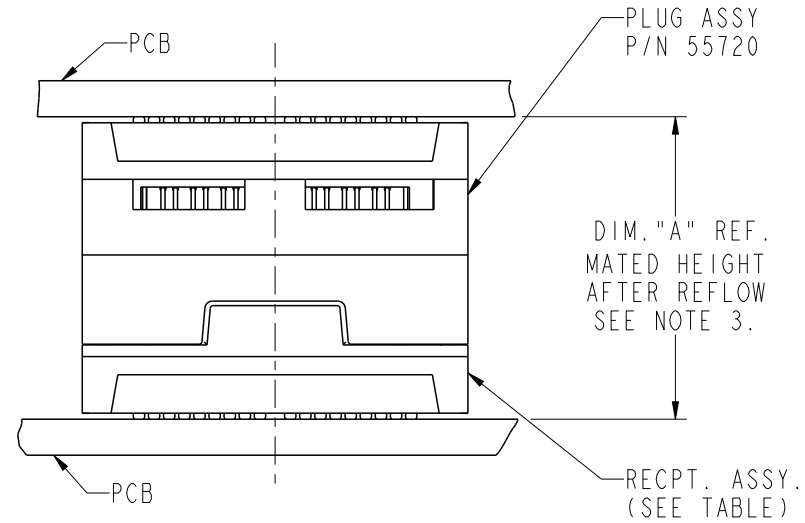

DIM. "A"	RECPT. ASSY. P/N
15	55701
25	55733



Copyright FCI.

spec ref -		dr Bill Lin 2010/02/02		projection 	mm 	size A4	scale 1:1	
tolerance std -		eng Nickor Zuo 2011/06/09				ecn no ELX-DG-003943-1		
-		chr Alex Cao 2011/06/24				rel level Released		
-		appr Pei-Ming Zheng 2011/06/27		product family GIG-Array		rev J		
surface 3.2 ASME Y14.5	linear	0.X	±0.30	 www.fci.com	title GIG-Array 10mm PLUG ASSY. 296 SIG. POS.	dwg no 55720	sheet 4 of 5	
		0.XX	±0.10					
		0.XXX	±0.05					
	angular	0°	±2°	cat. no. -	Product - Customer Drw			

PRODUCT NUMBER	SOLDER BALL COMPOSITION	CONTACT PLATING PERFORMANCE LEVEL
55720-001	STANDARD (EUTECTIC)	PERFORMANCE-BASED PLATING, QUALIFIED TO MEET THE REQUIREMENTS OF FCI PRODUCT SPECIFICATION GS-12-192, INCLUDING TELCORDIA CENTRAL OFFICE Au over Ni
55720-001LF	LEADFREE	
55720-201	STANDARD (EUTECTIC)	
55720-201LF	LEADFREE	

NOTES:

- ① MATERIAL:
HOUSING: LCP
CONTACT: COPPER ALLOY
PLATING (CONTACT): Au OVER Ni.
UL RATING: 94 V-0
SOLDER BALL: (SEE TABLE) EUTECTIC SnPb OR LEADFREE 95.5 Sn/4Ag/0.5Cu
- ② SOLDER BALLS WILL NOT BE PERFECT SPHERICAL SHAPE DUE TO REFLOW ATTACHMENT.
- ③ MATED HEIGHT EFFECTED BY CUSTOMERS' PCB PAD SIZE, PLATING, SOLDER REFLOW PROFILE & SOLDER PASTE.
- ④ CONTACTS IN ROWS A,C,E,G,J,K,M,P,R AND T ARE SINGLE BEAM CONTACTS, TYPICALLY USED AS GROUND PINS.
(NOTE: CONTACTS IN ROWS J & K ARE TIED TOGETHER [COMMONED])
- ⑤ CONTACTS IN ROWS B,D,F,H,L,N,Q AND S ARE DUAL BEAM CONTACTS, TYPICALLY USED AS SIGNAL PINS.

NOTES CONTINUED

- ⑥ SPECIFIED POSITIONAL TOLERANCE DEFINES PAD TO PAD LOCATION WITHIN LAND PATTERN. POSITIONAL TOLERANCE OF LAND PATTERN TO FUDICIAL MARKS OR PCB DATUMS SHALL BE DEFINED BY CUSTOMER. FOR RECOMMENDED PRODUCT APPLICATION AND PCB DESIGN DETAILS, SEE DOC. NO. GS-20-016.
- ⑦ FOR PROPER APPLICATION FOLLOW FCI APPLICATION SPECIFICATION GS-20-033 LEADFREE SOLDER BALLS WILL NOT SOLDER PROPERLY IN A LEADED SOLDER PROCESS DUE TO A HIGHER REFLOW TEMPERATURE, LEADFREE PRODUCT IS THEREFORE NOT BACKWARDS COMPATIBLE WITH LEADED OR SOME SOLDERING APPLICATIONS. REFERENCE FCI APPLICATION SPECIFICATION.
- ⑧ THIS PRODUCT MEETS THE EUROPEAN UNION DIRECTIVES AND OTHER COUNTRY REGULATIONS AS DESCRIBED IN GS-22-008. PRODUCT MEETING WITH THIS DIRECTIVE IS IDENTIFIED IN THE LOT CODE NUMBER MARKED ON EACH PART BY HAVING AN "X" IN THE SEVENTH CHARACTER POSITION.



Copyright FCI.

spec ref	-	dr	Bill Lin	2010/02/02	projection 	mm 	size	A4	scale	1:1	
tolerance std	TOLERANCES UNLESS OTHERWISE SPECIFIED	eng	Nickor Zuo	2011/06/09			product family	GIG-Array	ecn no	ELX-DG-003943-1	
-		chr	Alex Cao	2011/06/24				rel level	Released		
-		appr	Pei-Ming Zheng	2011/06/27	surface	3.2		linear	0.X	±0.30	www.fci.com
ASME Y14.5	angular	0°	±2°	title	GIG-Array		10mm PLUG ASSY. 296 SIG. POS.	cat. no.	-	Product - Customer Drw	
							dwg no	55720		rev	J



Компания «ЭлектроПласт» предлагает заключение долгосрочных отношений при поставках импортных электронных компонентов на взаимовыгодных условиях!

Наши преимущества:

- Оперативные поставки широкого спектра электронных компонентов отечественного и импортного производства напрямую от производителей и с крупнейших мировых складов;
- Поставка более 17-ти миллионов наименований электронных компонентов;
- Поставка сложных, дефицитных, либо снятых с производства позиций;
- Оперативные сроки поставки под заказ (от 5 рабочих дней);
- Экспресс доставка в любую точку России;
- Техническая поддержка проекта, помощь в подборе аналогов, поставка прототипов;
- Система менеджмента качества сертифицирована по Международному стандарту ISO 9001;
- Лицензия ФСБ на осуществление работ с использованием сведений, составляющих государственную тайну;
- Поставка специализированных компонентов (Xilinx, Altera, Analog Devices, Intersil, Interpoint, Microsemi, Aeroflex, Peregrine, Syfer, Eurofarad, Texas Instrument, Miteq, Cobham, E2V, MA-COM, Hittite, Mini-Circuits, General Dynamics и др.);

Помимо этого, одним из направлений компании «ЭлектроПласт» является направление «Источники питания». Мы предлагаем Вам помощь Конструкторского отдела:

- Подбор оптимального решения, техническое обоснование при выборе компонента;
- Подбор аналогов;
- Консультации по применению компонента;
- Поставка образцов и прототипов;
- Техническая поддержка проекта;
- Защита от снятия компонента с производства.



Как с нами связаться

Телефон: 8 (812) 309 58 32 (многоканальный)

Факс: 8 (812) 320-02-42

Электронная почта: org@eplast1.ru

Адрес: 198099, г. Санкт-Петербург, ул. Калинина, дом 2, корпус 4, литера А.