

DESCRIPTION

The MP1488 is a step-up converter designed for driving up to 27 WLEDs (9 strings of 3 WLEDs each) from a 5V system rail. The MP1488 uses a current mode, fixed frequency architecture to regulate the LED current, which is measured through an external current sense resistor. Its low 104mV feedback voltage reduces power loss and improves efficiency. The OV pin monitors the output voltage and turns off the converter if an over-voltage condition is present due to an open circuit condition.

The MP1488 includes under-voltage lockout, current limiting and thermal overload protection preventing damage in the event of an output overload.

The MP1488 is available in a small 6-pin TSOT23 package.

FEATURES

- 2.5V to 6V Input Voltage Range
- On Board Power MOSFET
- Drives up to 27 White LEDs at 5V Input
- Up to 92% Efficiency
- Over 1MHz Fixed Switching Frequency
- Open Load Shutdown
- Low 104mV Feedback Voltage
- Soft-Start/PWM Dimming
- UVLO, Thermal Shutdown
- Internal 800mA Current Limit
- Available in a TSOT23-6 Package

APPLICATIONS

- Cell Phones
- Handheld Computers and PDAs
- Digital Still Cameras
- Small LCD Displays

All MPS parts are lead-free, halogen free, and adhere to the RoHS directive. For MPS green status, please visit MPS website under Quality Assurance. "MPS" and "The Future of Analog IC Technology" are Registered Trademarks of Monolithic Power Systems, Inc.

TYPICAL APPLICATION

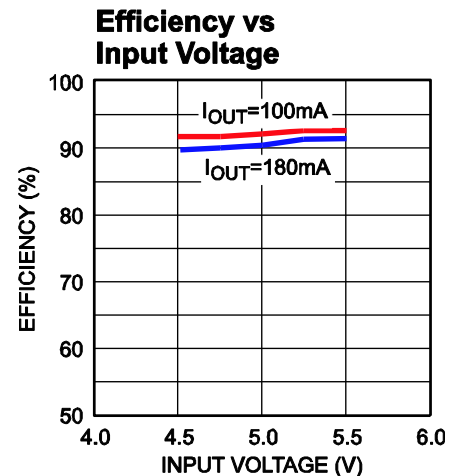
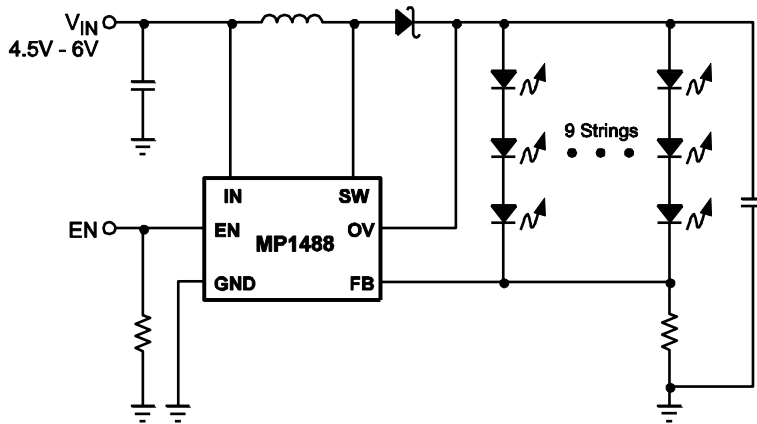

ORDERING INFORMATION

Part Number*	Package	Top Marking
MP1488DJ	TSOT23-6	<i>See Below</i>

* For Tape & Reel, add suffix -Z (e.g. MP1488DJ-Z).
 For RoHS compliant packaging, add suffix -LF (e.g. MP1488DJ-LF-Z)

TOP MARKING

| Z9YW

Z9: product code of MP1488DJ;
 Y: year code;
 W: week code:

PACKAGE REFERENCE

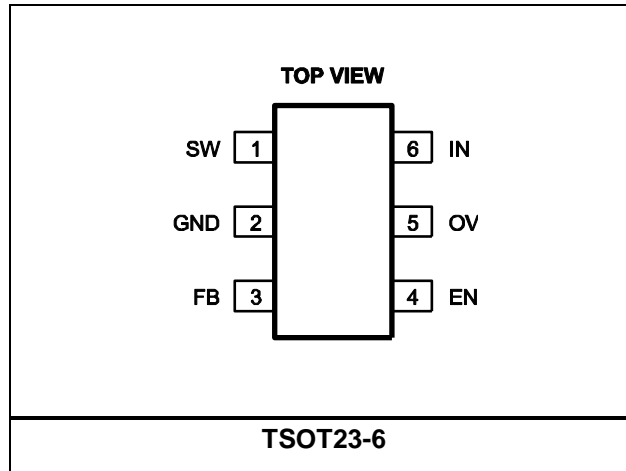

ABSOLUTE MAXIMUM RATINGS ⁽¹⁾

SW Pin -0.5V to +28.5V
All Other Pins..... -0.3V to +6.5V
Storage Temperature..... -55°C to +150°C

Recommended Operating Conditions ⁽²⁾

IN Supply Voltage 2.5V to 6V
Output Voltage..... V_{IN} to 25V
Operating Temperature..... -40°C to +85°C

Thermal Resistance ⁽³⁾	θ_{JA}	θ_{JC}
TSOT23-6	220	110 .. °C/W

Notes:

- 1) Exceeding these ratings may damage the device.
- 2) The device is not guaranteed to function outside of its operating conditions.
- 3) Measured on approximately 1" square of 1 oz copper.

ELECTRICAL CHARACTERISTICS

$V_{IN} = V_{EN} = 5V$, $T_A = +25^\circ C$, unless otherwise noted.

Parameters	Symbol	Condition	Min	Typ	Max	Units
Operating Input Voltage	V_{IN}		2.5		6	V
Supply Current (Shutdown)		$V_{EN} = 0V$		0.1	1	μA
Supply Current (Quiescent)		$V_{FB} = 0.15V$		690	750	μA
Switching Frequency	f_{SW}		1.0	1.3	1.5	MHz
Maximum Duty Cycle		$V_{FB} = 0V$	85	92		%
Under Voltage Lockout						
IN Under Voltage Lockout	UVLO	V_{IN} Rising		2.25	2.45	V
Under Voltage Lockout Hysteresis				92		mV
Open Lamp Shutdown Threshold	V_{OV}	V_{OV} Rising		28		V
Enable						
EN Threshold		V_{EN} Rising, $V_{IN} = 5V$	1.0	1.35	1.6	V
EN Threshold		V_{EN} Rising, $V_{IN} = 2.5V$	0.8			V
EN Hysteresis				90		mV
EN Input Bias Current		$V_{EN} = 0V, 5V$			1	μA
Feedback						
FB Voltage			94	104	114	mV
FB Input Bias Current		$V_{FB} = 0.1V$	-600	-300		nA
Output Switch						
SW On-Resistance ⁽⁴⁾	R_{ON}			0.5		Ω
SW Current Limit ⁽⁴⁾		Duty Cycle = 60%		800		mA
Thermal Shutdown ⁽⁴⁾				160		$^\circ C$

Notes:

4) Guaranteed by design.

PIN FUNCTIONS

TSOT23-6 Pin #	Name	Description
1	SW	Power Switch Output. SW is the drain of the internal MOSFET switch. Connect the power inductor and output rectifier to SW. SW can swing between GND and 25V.
2	GND	Ground.
3	FB	Feedback Input. The MP1488 regulates the voltage across the current sense resistor between FB and GND. Connect a current sense resistor from the bottom of the LED string to GND. Connect the bottom of the LED string to FB. The regulation voltage is 104mV.
4	EN	Regulator On/Off Control Input. A high input at EN turns on the converter, and a low input turns it off. When not used, connect EN to the input source for automatic startup. The EN pin cannot be left floating.
5	OV	Over Voltage Input. OV measures the output voltage for open circuit protection. Connect OV to the output at the top of the LED string.
6	IN	Input Supply Pin. Must be locally bypassed.

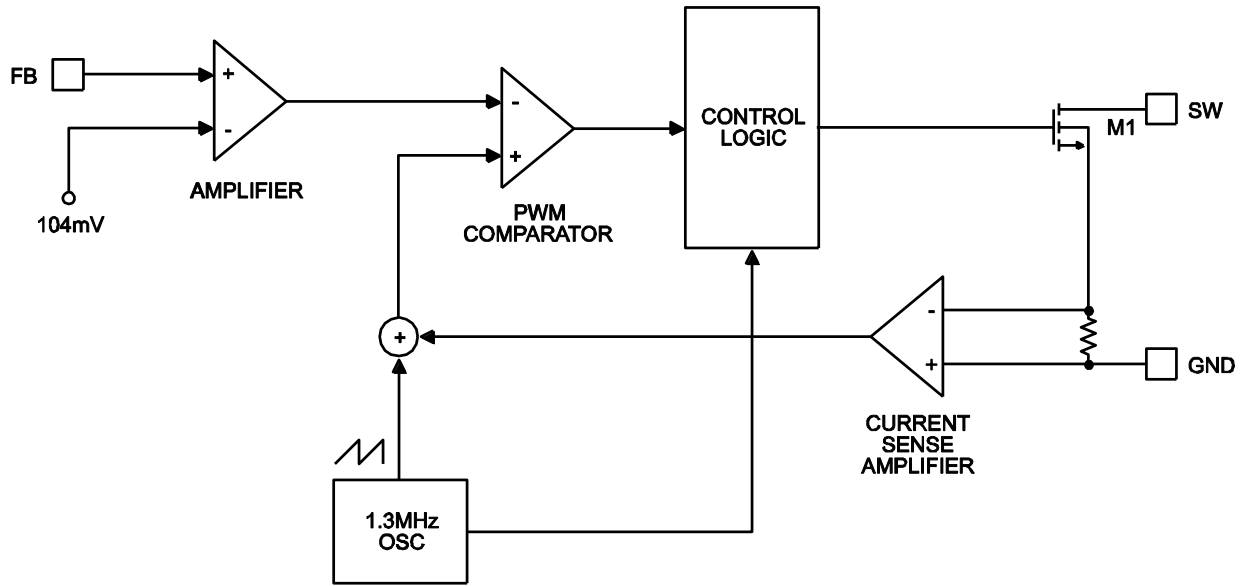

Figure 1—Functional Block Diagram

OPERATION

The MP1488 uses a constant frequency, peak current mode boost regulator architecture to regulate the strings of white LEDs. Refer to the block diagram in Figure 1 for details.

At the start of each oscillator cycle the FET is turned on through the control circuitry. To prevent sub-harmonic oscillations at duty cycles greater than 50%, a stabilizing ramp is added to the output of the current sense amplifier and the result is fed into the positive input of the PWM comparator. When this voltage equals the output voltage of the error amplifier the power FET is turned off.

The voltage at the output of the error amplifier is an amplified version of the difference between the 104mV reference voltage and the feedback voltage. In this way the peak current level keeps the output in regulation.

If the feedback voltage starts to drop, the output of the error amplifier increases. This results in more current flowing through the power FET, thus increasing the power delivered to the output.

APPLICATION INFORMATION

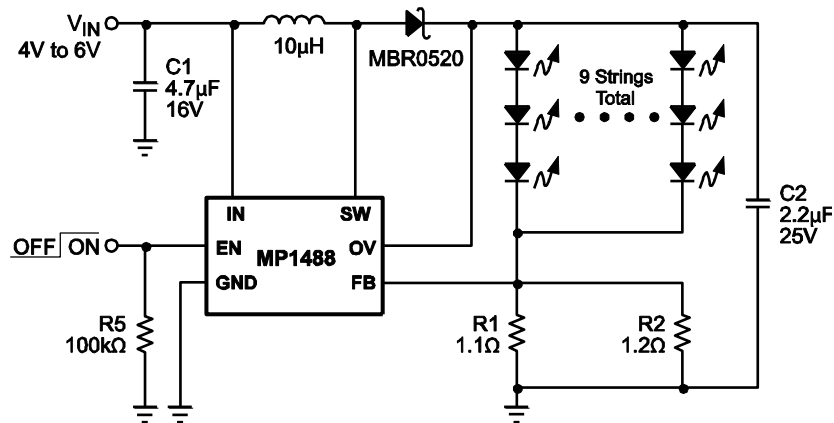

Figure 2—Circuit for Driving 27 WLEDs

A typical application circuit is provided in Figure 2. The 27 white LEDs can be driven from a voltage supply range of 4V to 6V at a total output current of 180mA. A 2.2µF output capacitor is sufficient for most applications but up to 1µF may be used. A 10µH inductor with low DCR (inductor resistance) is recommended to improve efficiency. A 4.7µF ceramic capacitor is recommended for the input capacitance in the real system. Schottky diodes with fast recovery and a low forward voltage are recommended. Schottky diodes with a 500mA rating are sufficient for the MP1488. The switching characteristics during normal operation can be seen in Figure 3. The MP1488 has internal soft-start to limit the amount of current through the IN pin at startup and to also limit the amount of overshoot on the output. The current limit is increased by a fourth every 40µs giving a total soft-start time of 120µs.

Steady State Operation

$V_{IN} = 5V$, 27 LEDs, 180mA

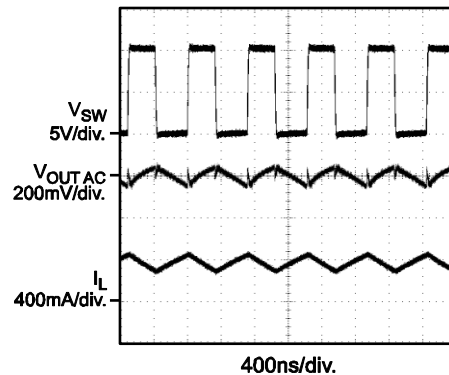

Figure 3—Steady State Operation

Figure 4 shows the startup behavior of the MP1488. The ramped voltage added to the current sense amplifier reduces the current output as the duty cycle increases. As more LEDs are added, the output voltage rises but the current that can be delivered to the load is reduced as well.

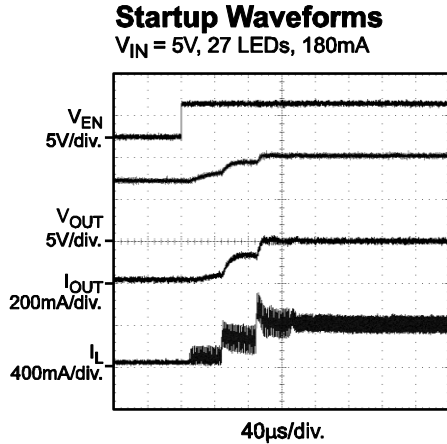

Figure 4—Startup Waveforms

Setting the LED Current

The LED current is controlled by the feedback resistors R1 and R2, as shown in Figure 2. The current through the LEDs is given by the equation:

$$I_{LED} = 104\text{mV} \times \frac{R1 + R2}{R1 \times R2}$$

Table 1 shows the selection of resistors for a given LED current.

Table 1— I_{LED} vs. R1

I_{LED} (mA)	R1 (Ω)	R2 (Ω)
10	10.4	N/A
50	2.08	N/A
100	1.04	N/A
150	1.5	1.3
180	1.2	1.1

Analog and Digital Dimming

There are three methods to control dimming for the MP1488 during normal operation. The first method uses DC voltage to control the feedback voltage. This is shown in Figure 6. As the DC voltage increases, current starts flowing down R1, R2 and R3. The loop will continue to regulate the feedback voltage to 104mV. Thus the current has to decrease through the LEDs by the same amount of current as is being injected from the DC voltage source. With a V_{DC} from 0V to 2V, the resistor values shown for R2 and R3 can control the LED current from 0mA to 20mA.

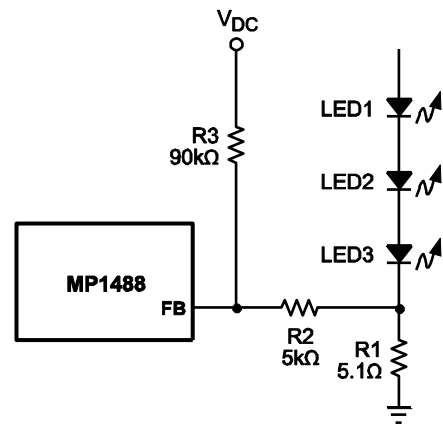

Figure 6—Dimming Control Using a DC Voltage

Other applications require a logic signal to control dimming. This is shown in Figure 7. The PWM signal is applied to the EN pin of the MP1488. The LEDs will switch between full load to completely shut off. The average current through the LEDs will increase proportionally to the duty cycle of the PWM signal. The PWM signal used in Figure 7 should be 1KHz or below due to the soft-start function.

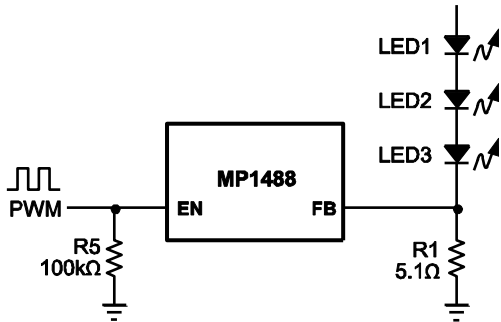

Figure 7—PWM Dimming Control Using a Logic Signal

If the PWM signal is above 1KHz, dimming can be achieved using the circuit shown in Figure 8.

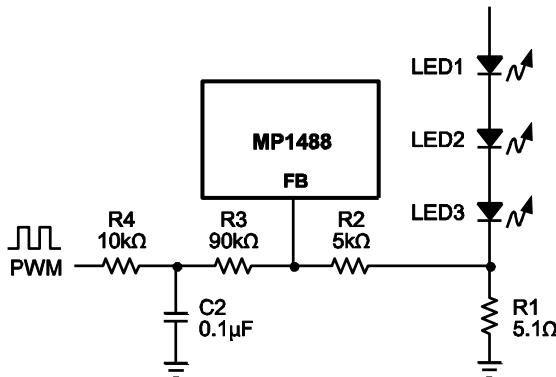

Figure 8— Dimming Control Using a Filtered PWM Signal

Open Load Protection

Open Load protection will shut off the MP1488 if the output voltage rises too high when the OV pin is tied to the output. In some cases an LED may fail. This will result in the feedback voltage always remaining at zero.

The part will run at maximum duty cycle boosting the output voltage higher and higher. By tying the OV pin to the top of the LED string the MP1488 can check for this condition. If the output exceeds 28V, the MP1488 will shut down. The part will not switch again until the power is recycled. Figure 9 shows the behavior of the MP1488 into an open load.

Startup Waveforms into an Open Load

$V_{IN} = 3.6V$

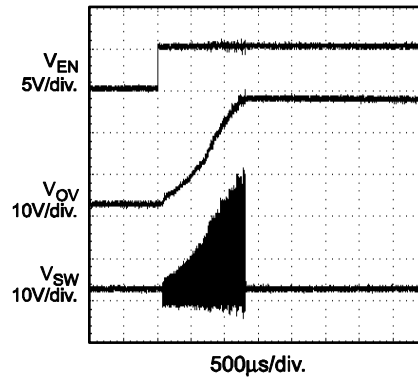

Figure 9—Startup Waveforms into an Open Load

Layout Considerations

Careful attention must be paid to the PCB board layout and component placement. Proper layout of the high frequency switching path is critical to prevent noise and electromagnetic interference problems. Due to high frequency switching, the length and area of all the traces connected to the switch node should be minimized.

PACKAGE INFORMATION

TSOT23-6

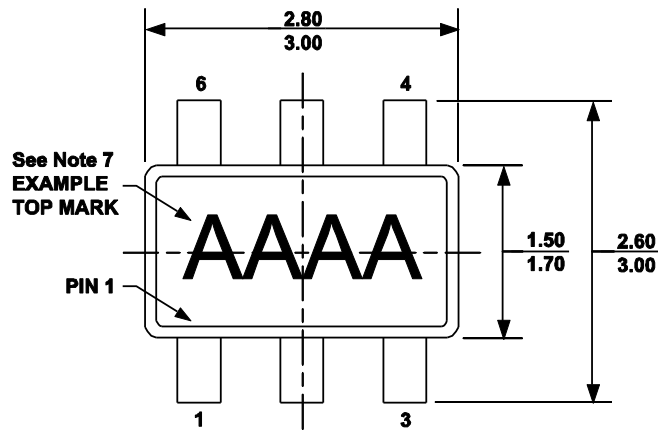

TOP VIEW

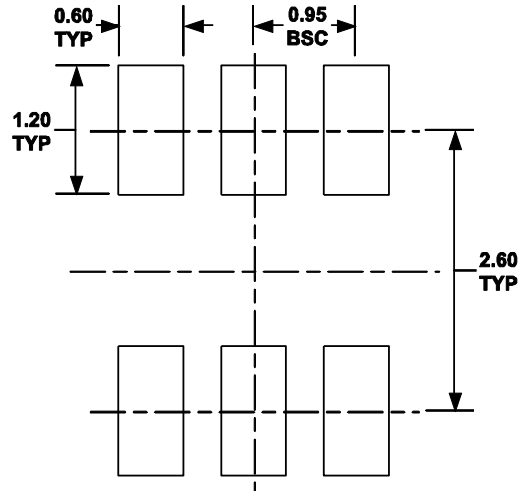

RECOMMENDED LAND PATTERN

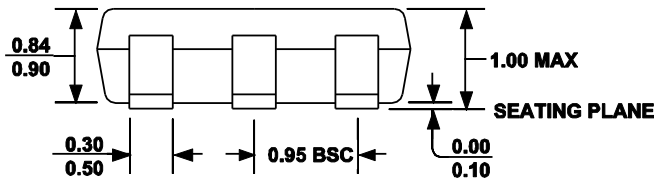

FRONT VIEW

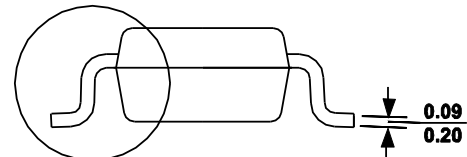

SEE DETAIL "A"

SIDE VIEW

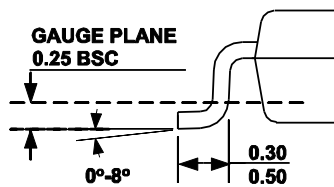

DETAIL "A"

NOTE:

- 1) ALL DIMENSIONS ARE IN MILLIMETERS.
- 2) PACKAGE LENGTH DOES NOT INCLUDE MOLD FLASH, PROTRUSION OR GATE BURR.
- 3) PACKAGE WIDTH DOES NOT INCLUDE INTERLEAD FLASH OR PROTRUSION.
- 4) LEAD COPLANARITY (BOTTOM OF LEADS AFTER FORMING) SHALL BE 0.10 MILLIMETERS MAX.
- 5) DRAWING CONFORMS TO JEDEC MO-193, VARIATION AB.
- 6) DRAWING IS NOT TO SCALE.
- 7) PIN 1 IS LOWER LEFT PIN WHEN READING TOP MARK FROM LEFT TO RIGHT, (SEE EXAMPLE TOP MARK)

NOTICE: The information in this document is subject to change without notice. Users should warrant and guarantee that third party Intellectual Property rights are not infringed upon when integrating MPS products into any application. MPS will not assume any legal responsibility for any said applications.



Компания «ЭлектроПласт» предлагает заключение долгосрочных отношений при поставках импортных электронных компонентов на взаимовыгодных условиях!

Наши преимущества:

- Оперативные поставки широкого спектра электронных компонентов отечественного и импортного производства напрямую от производителей и с крупнейших мировых складов;
- Поставка более 17-ти миллионов наименований электронных компонентов;
- Поставка сложных, дефицитных, либо снятых с производства позиций;
- Оперативные сроки поставки под заказ (от 5 рабочих дней);
- Экспресс доставка в любую точку России;
- Техническая поддержка проекта, помощь в подборе аналогов, поставка прототипов;
- Система менеджмента качества сертифицирована по Международному стандарту ISO 9001;
- Лицензия ФСБ на осуществление работ с использованием сведений, составляющих государственную тайну;
- Поставка специализированных компонентов (Xilinx, Altera, Analog Devices, Intersil, Interpoint, Microsemi, Aeroflex, Peregrine, Syfer, Eurofarad, Texas Instrument, Miteq, Cobham, E2V, MA-COM, Hittite, Mini-Circuits, General Dynamics и др.);

Помимо этого, одним из направлений компании «ЭлектроПласт» является направление «Источники питания». Мы предлагаем Вам помощь Конструкторского отдела:

- Подбор оптимального решения, техническое обоснование при выборе компонента;
- Подбор аналогов;
- Консультации по применению компонента;
- Поставка образцов и прототипов;
- Техническая поддержка проекта;
- Защита от снятия компонента с производства.



Как с нами связаться

Телефон: 8 (812) 309 58 32 (многоканальный)

Факс: 8 (812) 320-02-42

Электронная почта: org@eplast1.ru

Адрес: 198099, г. Санкт-Петербург, ул. Калинина, дом 2, корпус 4, литера А.