



**HITEK POWER® XR150**  
X-RAY POWER SUPPLY MODULE





# **Complete high voltage power source**

for industrial  
x-ray systems,  
elemental analysis  
equipment,  
x-ray diffraction  
spectrometers,  
and materials  
process monitoring  
applications



**Specifically developed for high-performance x-ray applications**, the compact and reliable XR150 series is surface mountable and built with superior high voltage stress control and packaging techniques. The filament is automatically controlled by integral beam loop control and the power stage utilizes a current-fed resonant push-pull converter to provide high efficiency and reliability.

## Features

- › 150 W high voltage output
- › 17 W floating filament
- › High accuracy and stability
  - Emission accuracy: 0.1%
  - Regulation: 0.1%
  - Stability: 100 ppm
- › Exceptionally compact
- › Remote operation
- › Analog or RS-232 control interface
- › Safety interlock
- › Extensive tube and system protection functions
- › CE marked for EU LV directive 2006/95/EC
- › EU RoHS compliant to 2002/95/EC

## Typical Applications

- › Inspection and analytical x-ray systems with floating filament tubes
  - X-ray fluorescence (XRF)
  - X-ray diffraction (XRD)
  - X-ray reflectivity (XRR)
  - X-ray imaging (XRI)
- › Industrial process x-ray systems
  - Elemental analysis equipment
  - Process quality, safety, compliance
  - Materials monitoring
  - Food safety inspection
- › Digital x-ray imaging and inspection
  - Industrial
  - Veterinary
  - Pharma, cellular, biotech
  - Security

**ASK US ABOUT DERIVATIVES AND SPECIAL PRODUCTS BUILT TO YOUR REQUIREMENTS.**



## SPECIFICATIONS

### Electrical Input

<b>Voltage</b>	24 VDC $\pm 1$ VDC
<b>Current</b>	11 A, max

### Electrical Output

<b>Voltage</b>	0 to -60 kV; full spec applies above -3 kV
<b>Current</b>	0 to -2.5 mA
<b>Power</b>	150 W, max
<b>Ripple</b>	< 100 V, peak to peak
<b>Filament</b>	0 to 3.7 A (4.5 V, max) Controlled by internal beam control loop

### Controls (Analog Version)

<b>Voltage Demand</b>	0 to 5 VDC demands 0 to -60 kV $\pm 0.5\%$ $\pm 100$ V
<b>Current Demand</b>	0 to 5 VDC demands 0 to -2.5 mA $\pm 2\%$ $\pm 5$ $\mu$ A
<b>Filament Limit</b>	Internally settable between 1 and 3.7 A

### Controls (RS-232 Version)

<b>Voltage Demand</b>	12 bit; 0 to FFF demands 0 to -60 kV $\pm 0.5\%$ $\pm 100$ V
<b>Current Demand</b>	12 bit; 0 to FFF demands 0 to -2.5 mA $\pm 2\%$ $\pm 5$ $\mu$ A
<b>Filament Standby</b>	12 bit; 0 to FFF demands 0 to 3.7 A

### Monitors (Analog)

<b>Output Voltage</b>	0 to 5 V $\pm 0.5\%$ $\pm 20$ mV for 0 to -60 kV
<b>Beam Current</b>	0 to 5 V $\pm 2\%$ $\pm 20$ mV for 0 to -2.5 mA
<b>Filament Current</b>	0 to 5 V $\pm 5\%$ $\pm 20$ mV for 0 to 3.7 A
<b>Filament Voltage</b>	0 to 5 V $\pm 5\%$ $\pm 20$ mV for 0 to 5 V

### Monitors (RS-232)

<b>Output Voltage</b>	12 bit; 0 to FFF represents 0 to -60 kV
<b>Output Current</b>	12 bit; 0 to FFF represents 0 to -2.5 mA
<b>Filament Current</b>	12 bit; 0 to FFF represents 0 to 3.7 A
<b>Filament Voltage</b>	12 bit; 0 to FFF represents 0 to 5 V

### Load Regulation, Output Voltage

<b>Static</b>	< 60 V no load to full load
<b>Dynamic</b>	< 3 kV, recovery to within 1% of previous setting within 200 msec
<b>Beam Current</b>	< $\pm 2$ $\mu$ A for a 10 to 100% of change of rated load

### Line Regulation

<b>Output Voltage</b>	< 60 V for a 1 V change in the 24 V supply
<b>Beam Current</b>	< $\pm 2$ $\mu$ A for a 1 V change in the 24 V supply

### Stability and Drift

<b>Temperature Coefficient</b>	100 ppm/ $^{\circ}$ C over operating temperature range
<b>Drift</b>	$\pm 0.1\%$ of rating over an eight-hour period after 30 min warmup

### Environmental

<b>Operating Temperature</b>	0 to +40 $^{\circ}$ C (+32 to +104 $^{\circ}$ F)
<b>Storage Temperature</b>	-20 to +85 $^{\circ}$ C (-4 to +185 $^{\circ}$ F)



SPECIFICATION	
<b>Humidity</b>	80% maximum relative humidity up to 31°C (88°F), reducing linearly to 50% at 40°C (104°F), non-condensing (ref BS EN61010-1)
<b>Vibration</b>	In accordance with BS EN60068-2-6:1995 transport, when contained in the original packaging
<b>Frequency Range</b>	10 to 500 Hz
<b>Acceleration</b>	20 m/sec <sup>2</sup> crossover at 58 Hz
<b>Displacement</b>	0.15 mm (0.006") max
<b>Altitude</b>	0 to 2000 m (0 to 6562')
<b>Installation Environment</b>	Installation category 1, pollution degree 2, indoor use only
<b>Cooling</b>	Fan assisted
<b>Connectors</b>	
<b>Input DC Power</b>	Deutsch IMC24-1602
<b>HV Output</b>	HiTek Power*-designed detachable poke home connector
<b>Filament Output</b>	HiTek Power*-designed detachable poke home connector
<b>Control Interface</b>	15-way, D-type socket (analog) 9-way, D-type socket (RS-232)
<b>Protection, Safety, and Compliance</b>	
<b>Protection</b>	Input voltage reverse polarity Over-temperature Over-current (continuous short circuit and intermittent arc) on both HV output and filament Over-voltage on both HV output and filament
<b>Safety</b>	This high voltage module meets the requirements of the Low Voltage Directive (LVD), 2006/95/EC by complying with BS EN61010-1:2001 when it is installed as a component part of other equipment and is CE marked accordingly.
<b>EMC</b>	This high voltage module is intended for installation as part of a system. Basic EMC filtering is provided.
<b>RoHS</b>	The XR150 series meets the requirements of EU Directive 2002/95/EC on the restriction of use of certain hazardous substances in electrical and electronic equipment (RoHS).
<b>Mechanical Specification</b>	
<b>Dimensions (W x H x D)</b>	80 mm x 179.5 mm x 320 mm; 3.15" x 7.07" x 12.6" (excluding fan)
<b>Weight</b>	8 kg (18 lb)
<b>Casing</b>	Aluminum, clear non-chrome passivate finish See outline drawing (analog version).



## ORDERING INFORMATION

Model	Output Voltage	Output Current
XR150-603*	-60 kV	2.5 mA

\*Please add the required suffix for control option to the part number:

A Analog control

C RS-232 control

Example: XR150-603C for RS-232 controlled unit

## INTERFACE CONNECTIONS

### Analog, 15-way, Female, D-Type Connector

FILAMENT CURRENT MONITOR	1	9	0 V (SIGNAL)
kV DEMAND	2	10	OVER-TEMPERATURE
0 V (SIGNAL)	3	11	NO CONNECTION
FILAMENT VOLTAGE MONITOR	4	12	RESERVED
BEAM CURRENT DEMAND	5	13	OVER-VOLTAGE
0 V (SIGNAL)	6	14	OVER-CURRENT
kV MONITOR	7	15	COMMON RETURN FOR 10 13 14
BEAM CURRENT MONITOR	8		

### Digital, Remote-Control (RS-232) 9-Way, Female, D-Type Connector

NO CONNECTION	1	6	NO CONNECTION
TXD	2	7	NO CONNECTION
RXD	3	8	NO CONNECTION
NO CONNECTION	4	9	NO CONNECTION
0 V	5		

 These component power supplies meet the requirements of EC directive 2006/95/EC (LVD).

Drawing dimensions are in mm (inches).  
Design developments may result  
in specification changes.

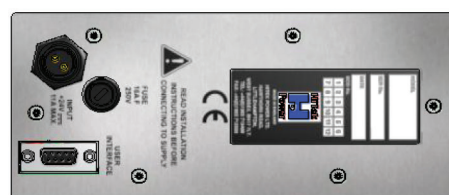
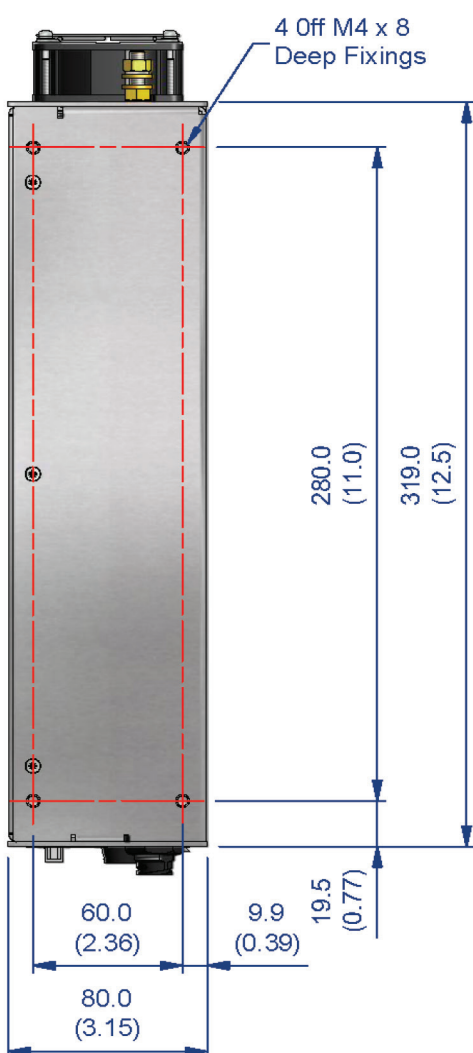
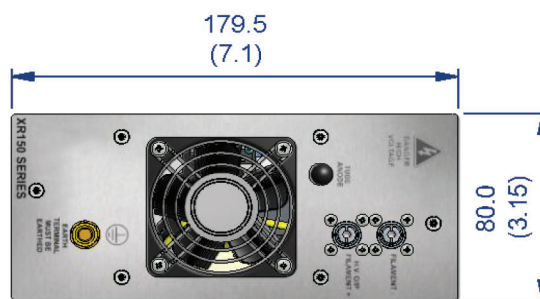



For international contact information, visit  
[advanced-energy.com](http://advanced-energy.com).





Компания «ЭлектроПласт» предлагает заключение долгосрочных отношений при поставках импортных электронных компонентов на взаимовыгодных условиях!

Наши преимущества:

- Оперативные поставки широкого спектра электронных компонентов отечественного и импортного производства напрямую от производителей и с крупнейших мировых складов;
- Поставка более 17-ти миллионов наименований электронных компонентов;
- Поставка сложных, дефицитных, либо снятых с производства позиций;
- Оперативные сроки поставки под заказ (от 5 рабочих дней);
- Экспресс доставка в любую точку России;
- Техническая поддержка проекта, помощь в подборе аналогов, поставка прототипов;
- Система менеджмента качества сертифицирована по Международному стандарту ISO 9001;
- Лицензия ФСБ на осуществление работ с использованием сведений, составляющих государственную тайну;
- Поставка специализированных компонентов (Xilinx, Altera, Analog Devices, Intersil, Interpoint, Microsemi, Aeroflex, Peregrine, Syfer, Eurofarad, Texas Instrument, Miteq, Cobham, E2V, MA-COM, Hittite, Mini-Circuits, General Dynamics и др.);

Помимо этого, одним из направлений компании «ЭлектроПласт» является направление «Источники питания». Мы предлагаем Вам помощь Конструкторского отдела:

- Подбор оптимального решения, техническое обоснование при выборе компонента;
- Подбор аналогов;
- Консультации по применению компонента;
- Поставка образцов и прототипов;
- Техническая поддержка проекта;
- Защита от снятия компонента с производства.



#### Как с нами связаться

**Телефон:** 8 (812) 309 58 32 (многоканальный)

**Факс:** 8 (812) 320-02-42

**Электронная почта:** [org@eplast1.ru](mailto:org@eplast1.ru)

**Адрес:** 198099, г. Санкт-Петербург, ул. Калинина, дом 2, корпус 4, литера А.