

mat'l. code		surface ISO 1302 ✓		tolerance ISO 406 ISO 1101		projection		product family	
ltr		ecn no		dr		date		CONAN®	
AG	ELX-N-14208	GM	03/07/13	tolerances unless otherwise specified		angles linear		title	
AH	ELX-N-22454	EH	10/11/15	.0±.30		INCH/MM		CONAN® CONNECTOR ASSEMBLY	
AJ	-	EH	12/12/15	.00±.20		scale 1:1		dwg no	
AK	ELX-N-26578	TONY	04/07/17	.000±.10		Amphenol FCI		sheet 1 of 7	
AL	ELX-N-26810	TONY	04/26/17	chr				91900	
AF	M08-0287	MHT	10/02/08	appd		Tim Yao		size	
sheet	revision	AL	AL	AL	AL	AL	AL	A3	
index	sheet	1	2	3	4	5	6	type Product Customer Drawing	

PRODUCT NUMBER  
SEE TABLE

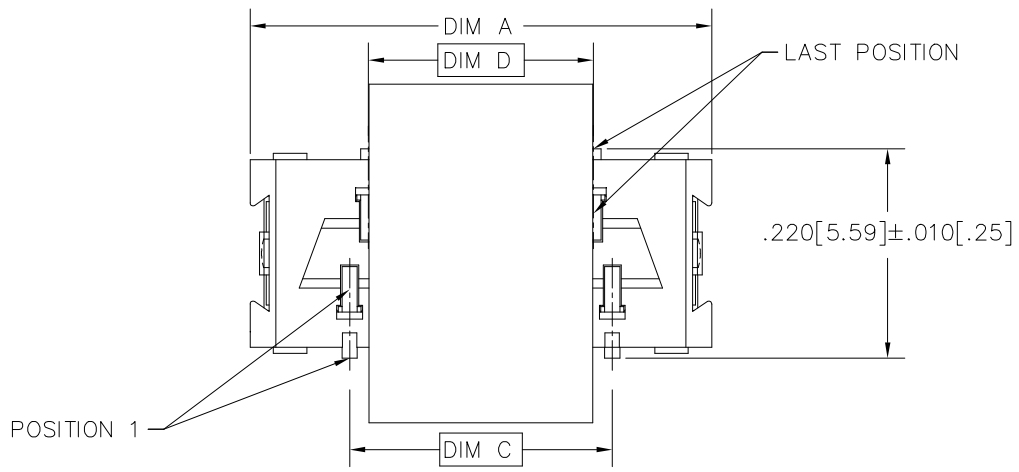

POSITION 1

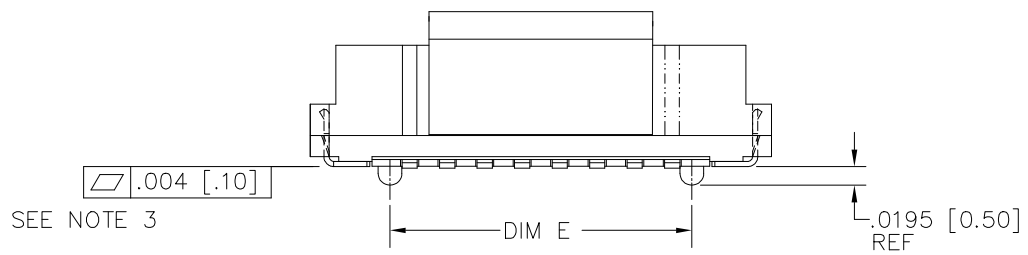

SEE NOTE 3

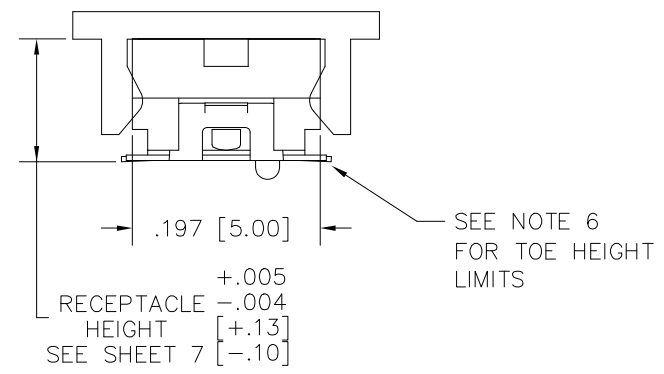

SEE NOTE 6  
FOR TOE HEIGHT  
LIMITS

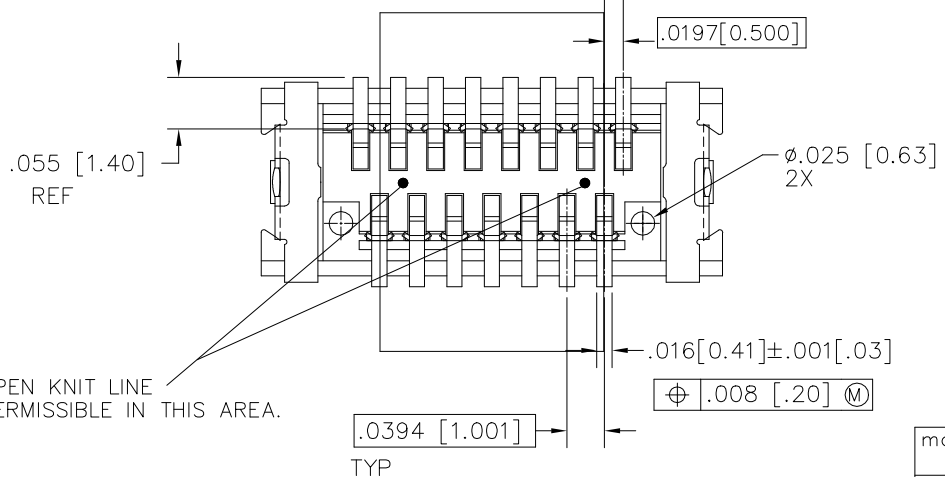

OPEN KNIT LINE  
PERMISSIBLE IN  
THIS AREA.

Amphenol  
FCI

© 2016 AFCI

mat'l. code		surface	tolerance	projection	product family
		ISO 1302 ✓	ISO 406 ISO 1101		CONAN®
ltr	ecn no	dr	date	tolerances unless otherwise specified	title
AL				.0±.30 .00±.20 .000±.10	CONAN® CONNECTOR ASSEMBLY
		angles	linear	INCH/MM	dwg no
		0°±x'		scale 1:1	sheet 2 of 7
		dr	Eric Huang	10/11/15	size
		eng	Eric Huang	10/11/15	A3
		chr			
		appd	Tim Yao	10/11/15	
sheet index		revision sheet			type Product Customer Drawing

PRODUCT NUMBER  
SEE TABLE

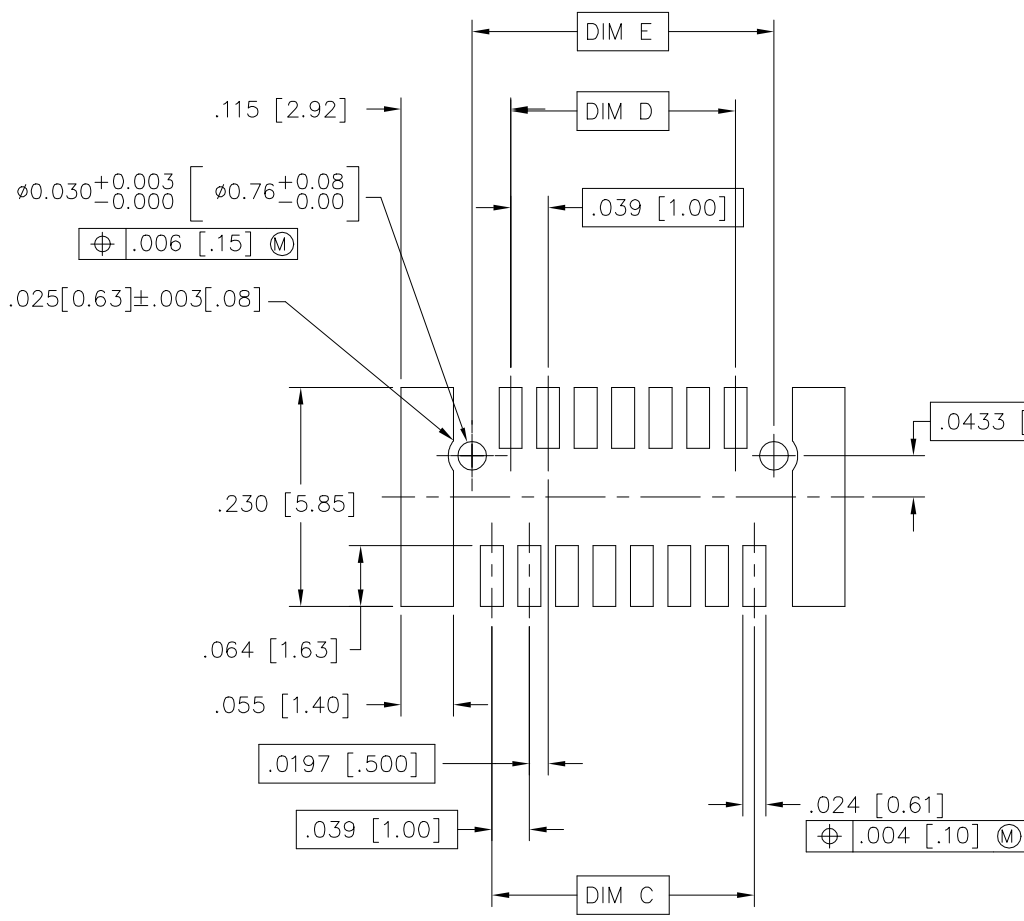

RECOMMENDED  
PAD LAYOUT

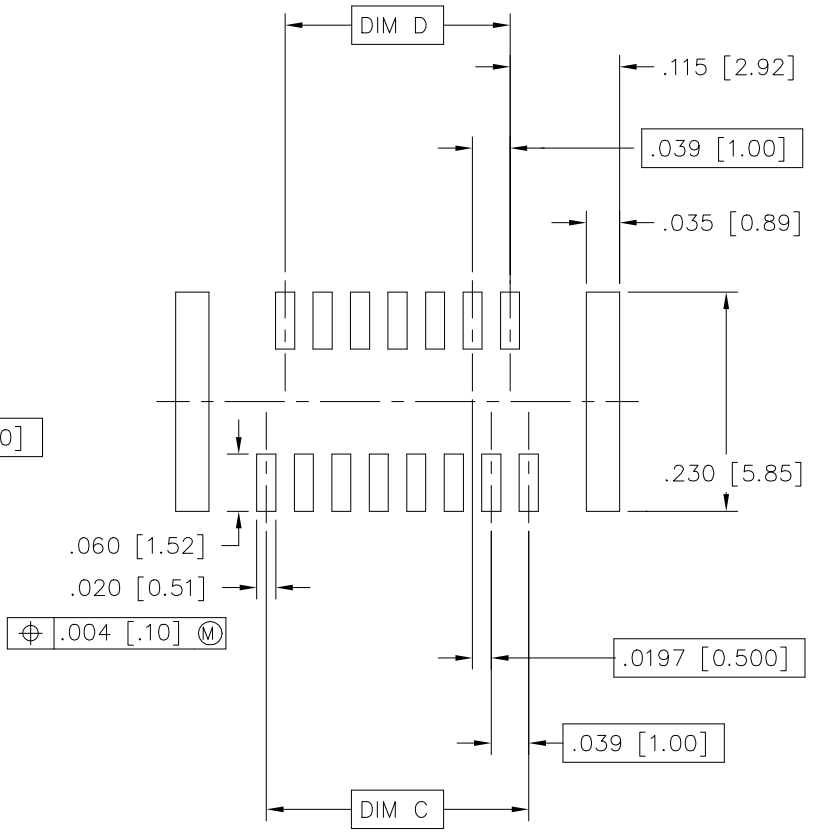

RECOMMENDED  
STENCIL LAYOUT  
FOR RECEPTACLE



© 2016 AFCI

mat'l. code		surface ISO 1302 <input checked="" type="checkbox"/>		tolerance ISO 406 ISO 1101		projection 		product family CONAN <sup>®</sup>	
ltr	ecn no	dr	date	tolerances unless otherwise specified		INCH/MM		title CONAN <sup>®</sup> CONNECTOR ASSEMBLY	
AL				angles	.0±.30			dwg no	
				linear	.00±.20			sheet 3 of 7	
				0'±x'	.000±.10	scale 1:1		size A3	
				dr	Eric Huang	10/11/15		Amphenol FCI	
				eng	Eric Huang	10/11/15		91900	
				chr				type Product Customer Drawing	
				appd	Tim Yao	10/11/15			
sheet index	revision sheet								

PRODUCT NUMBER  
SEE TABLE

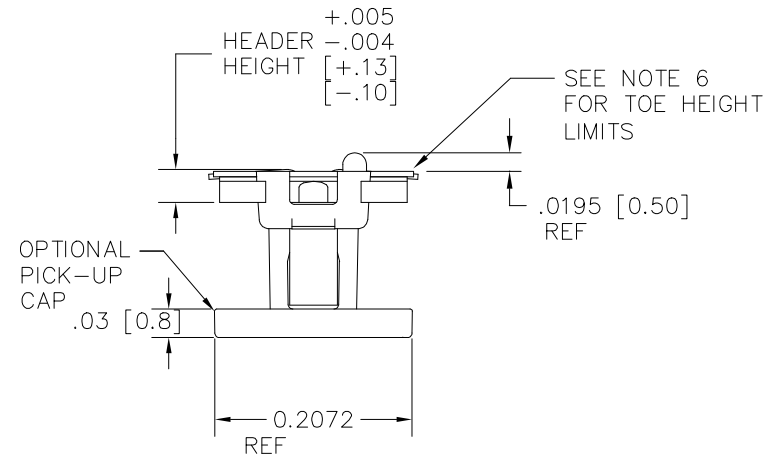
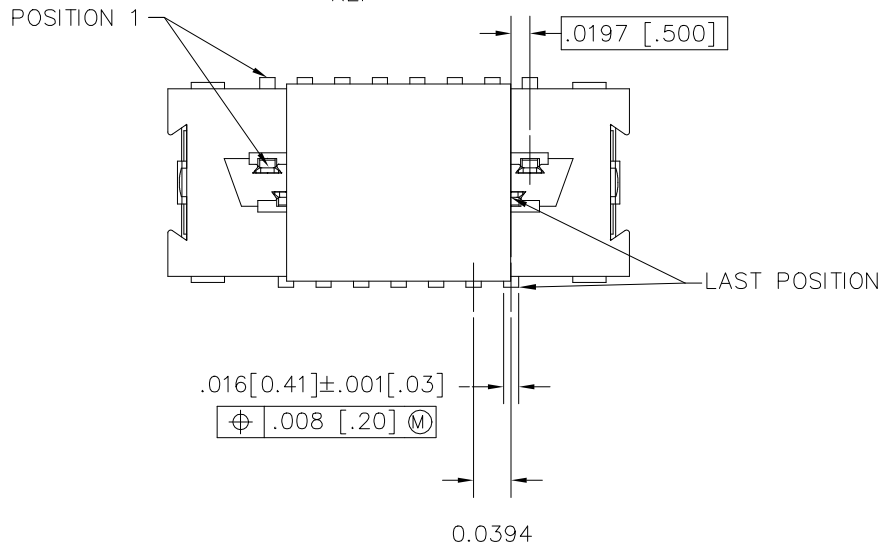
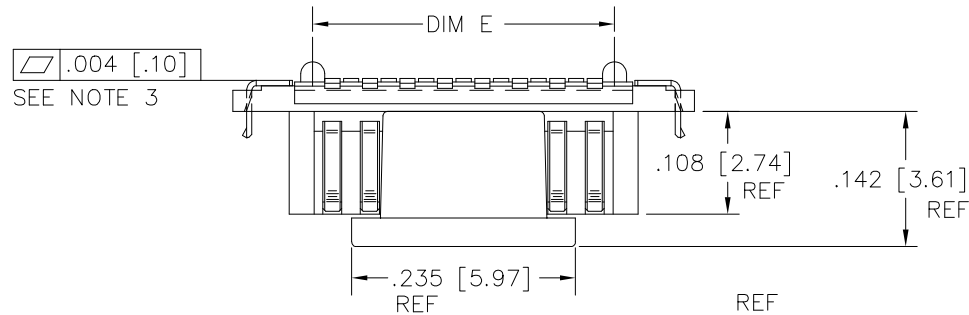
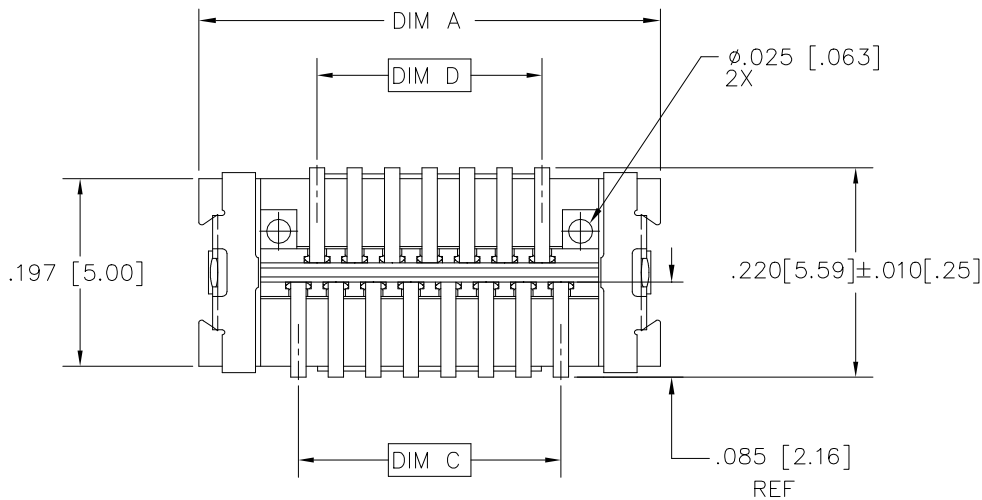

mat'l. code		surface ISO 1302 ✓		tolerance ISO 406 ISO 1101		projection 1101		product family CONAN®	
ltr	ecn	no	dr	date	tolerances unless otherwise specified		title		
AL					angles	linear	INCH/MM	CONAN® CONNECTOR ASSEMBLY	
					0°±x'		scale 1:1	sheet 4 of 7	
					dr	Eric Huang	10/11/15	size A3	
					eng	Eric Huang	10/11/15	dwg no 91900	
					chr			type Product Customer Drawing	
					appd	Tim Yao	10/11/15		
sheet index	revision sheet								

PRODUCT NUMBER  
SEE TABLE

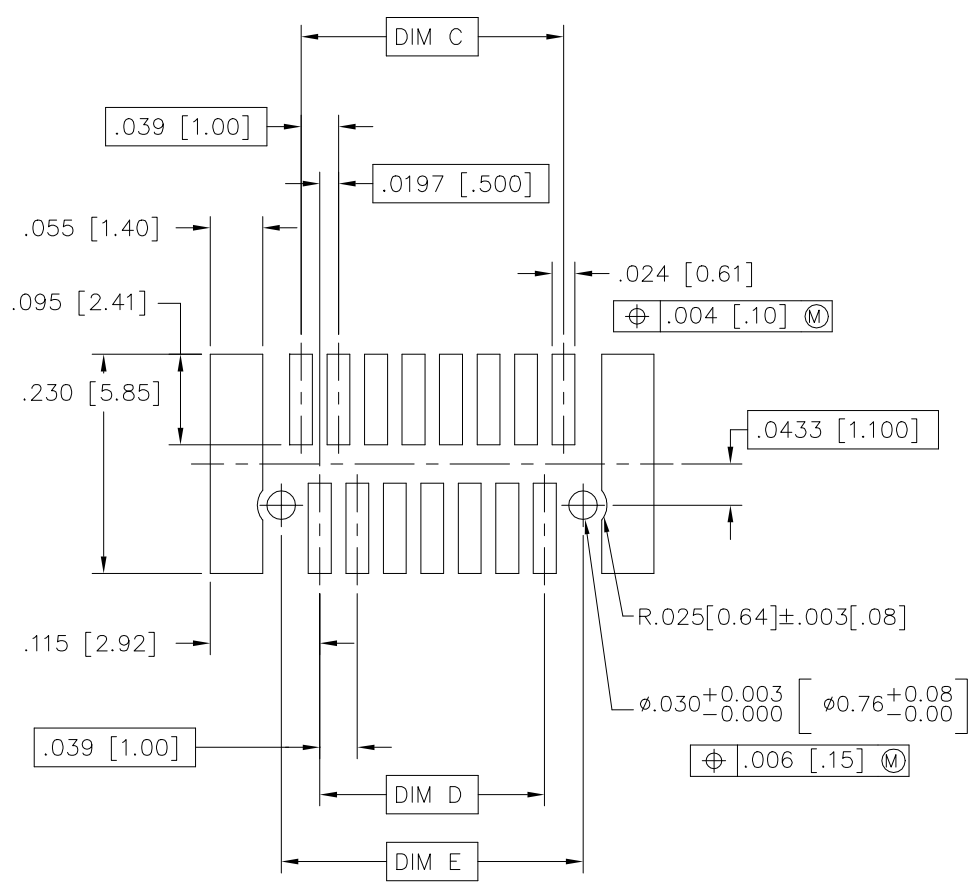

RECOMMENDED  
PAD LAYOUT

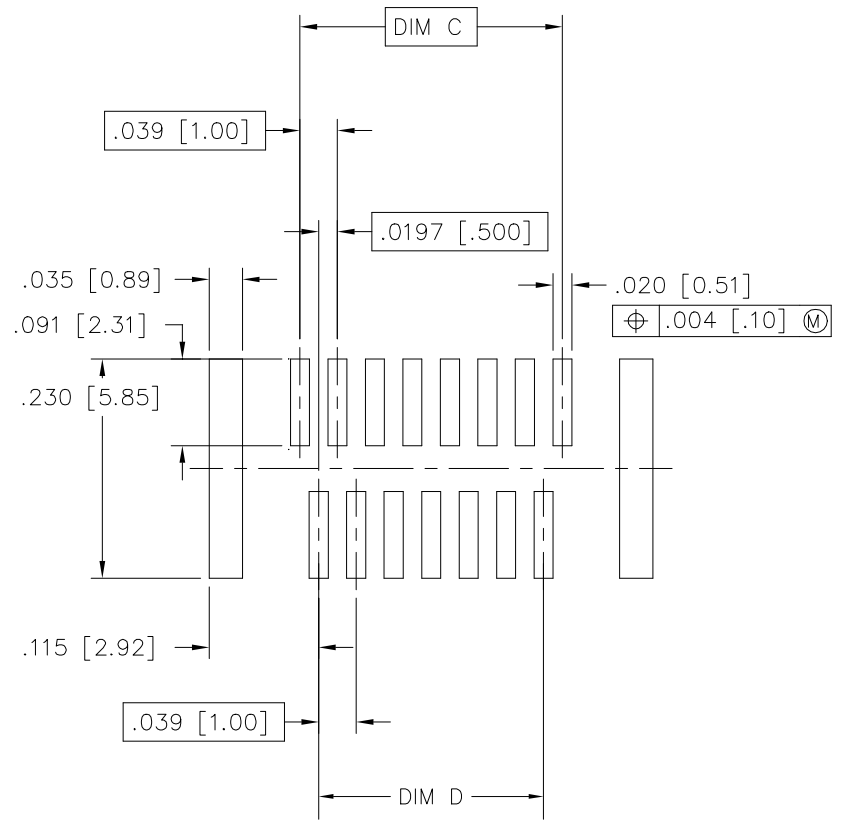

RECOMMENDED  
STENCIL LAYOUT  
FOR HEADER

Amphenol  
FCI

© 2016 AFCI

mat'l. code		surface ISO 1302 ✓		tolerance ISO 406 ISO 1101		projection 1:1		product family CONAN®	
ltr	ecn no	dr	date	tolerances unless otherwise specified		title		CONAN® CONNECTOR ASSEMBLY	
AL				angles	linear	INCH/MM		sheet 5 of 7	
				0'±x'		scale 1:1		size A3	
		dr	Eric Huang	10/11/15		Amphenol FCI		dwg no 91900	
		eng	Eric Huang	10/11/15				type Product Customer Drawing	
		chr							
		appd	Tim Yao	10/11/15					
sheet index	revision sheet								

PRODUCT NUMBER	POS	DIM "A"	DIM "C"	DIM "D"	DIM "E"
919TC-WXY09	9	.366 [9.30]	.157 [4.00]	.118 [3.00]	.1990 [5.055]
-WXY09LF					
-WXY11	11	.406 [10.30]	.197 [5.00]	.157 [4.00]	.2380 [6.045]
-WXY11LF					
-WXY15	15	.484 [12.30]	.276 [7.00]	.236 [6.00]	.3170 [8.052]
-WXY15LF					
-WXY21	21	.602 [15.30]	.394 [10.00]	.354 [9.00]	.4350 [11.049]
-WXY21LF					
-WXY25	25	.681 [17.30]	.472 [12.00]	.433 [11.00]	.5140 [13.056]
-WXY25LF					
-WXY31	31	.800 [20.30]	.591 [15.00]	.551 [14.00]	.6320 [16.053]
-WXY31LF					
-WXY41	41	.996 [25.30]	.787 [20.00]	.748 [19.00]	.8290 [21.057]
-WXY41LF					
-WXY51	51	1.193 [30.30]	.984 [25.00]	.945 [24.00]	1.0260 [26.060]
-WXY51LF					
-WXY69	69	1.547 [39.30]	1.339 [34.00]	1.299 [33.00]	1.3800 [35.052]
-WXY69LF					

NOTES:

1. MATERIALS:

RECEPTACLE HOUSING - LCP, UL-94V-0. COLOR: NATURAL.

RECEPTACLE TERMINALS - COPPER ALLOY, PLATED WITH 15u"/.38u GXT™ IN CONTACT AREA AND 100u"/2.54u Sn ON SOLDER LEGS WITH AN OVERALL 50u"/1.27u Ni UNDERPLATE.

HEADER HOUSING - LCP, UL-94V-0. COLOR: NATURAL.

HEADER TERMINALS - COPPER ALLOY, PLATED WITH 15u"/.38u GXT™ IN CONTACT AREA AND 100u"/2.54u Sn ON SOLDER LEGS WITH AN OVERALL 50u"/1.27u Ni UNDERPLATE.

RETENTION DEVICE - BRASS, PLATED WITH 100u"/2.54u Sn OVER NICKEL.

2. REFERENCE GS-12-006 FOR PRODUCT PERFORMANCE DATA.

3. SEE TA-774 FOR FURTHER DESCRIPTION OF HOW THIS DIMENSION IS APPLIED.

4. PICK AND PLACE CAP OR TAPE IS ONLY AVAILABLE WITH OPTION 3 PACKAGING. (PSA ADHESIVE SEALED). ALSO, PSA PACKAGING REQUIRES A PICK AND PLACE CAP.

5. RECOMMENDED SOLDER PASTE THICKNESS IS .006 TO .008 INCHES THICK.

6. THE TOE HEIGHT OF THE SOLDER TAIL SHALL BE MEASURED FROM THE LOWEST POINT OF THE .004 CO-PLANARITY GRAVITY PLANE. THIS MEASUREMENT IS NOT TO EXCEED A WINDOW OF .000 TO .007 INCHES.

7. THREE SLOTS MAY BE LOCATED AT EITHER END OF HOUSING.

8. 5.50mm MATED HEIGHT IS ONLY AVAILABLE IN 9, 15 AND 31 POS.

9. 7.50mm MATED HEIGHT IS ONLY AVAILABLE IN 9 POS.

10. APPLIES TO 91921-3XYZZ AND 91931- 3XYZZ OPTIONS ONLY.

11. THE HOUSING WILL WITHSTAND EXPOSURE TO 260°C PEAK TEMPERATURE FOR 30 SECONDS IN A CONVECTION INFRA RED OR VAPOR PHASE REFLOW OVEN. SEE APPLICATION/PROCEDURES IF THEY ARE AVAILABLE

13. PRODUCT WITH "LF" AT THE END MEETS EUROPEAN UNION DIRECTIVES AND OTHER COUNTRY REGULATION AS DESCRIBED IN GS-22-008.

Amphenol FCI

© 2016 AFCI

mat'l. code		surface	tolerance	projection	product family
		ISO 1302 ✓	ISO 406 ISO 1101		CONAN®
ltr	ecn no	dr	date	tolerances unless otherwise specified	title
AL				.0±.30 INCH/MM .00±.20 scale 1:1 .000±.10	CONAN® CONNECTOR ASSEMBLY
				angles linear	
				0°±x'	
		dr	Eric Huang	10/11/15	dwg no sheet 6 of 7 size
		engr	Eric Huang	10/11/15	91900 A3
		chr			
		appd	Tim Yao	10/11/15	type Product Customer Drawing
sheet index	revision sheet				

# CONAN® ASSEMBLY PART NUMBER

## 919 T C - W X Y ZZ LF

LEAD FREE OPTION  
SEE NOTE 12

TYPE	T
HEADER WITH NO PEGS	0
HEADER WITH PEGS	1
RECEPTACLE WITH NO PEGS	2
RECEPTACLE WITH PEGS	3

PICK AND PLACE CAP OR TAPE (NOTE 4)	C
WITHOUT CAP OR TAPE	0
WITH CAP	1
WITH TAPE (RECEPTACLE ONLY)	2

PACKAGING	W
TUBE	2
PRESSURE SEALED TAPE & REEL	3

NOTE 4

Y	HEADER HEIGHT	RECEPTACLE HEIGHT	MATED HEIGHT
1	.034 [.86]	.129 [3.28]	.163 [4.15]
2	.048 [1.23]	SEE Y=1 FOR ALL RECEPTACLES	.177 [4.50]
3	.068 [1.73]		.197 [5.00]
4	.107 [2.72]		.236 [6.00]
5	.1465 [3.721]		.276 [7.00]
* 6	.088 [2.23]		.216 [5.50]
** 7	.1665 [4.229]		.296 [7.52]

\* NOTE 8  
\*\* NOTE 9

X	PLATING
1	15u"/.38u GXT™
2	30u"/.76u GXT™

ZZ	NUMBER OF POSITIONS
09	9
11	11
15	15
21	21
25	25
31	31
41	41
51	51
69	69

EXAMPLE: 91921-31125LF  
 IS A CONAN® RECEPTACLE ASSEMBLY,  
 HAVING NO PEGS AND WITH A PICK AND PLACE CAP.  
 IT ALSO HAS GXT™ PLATING, IS .13 [3.2] HIGH AND 25  
 POSITIONS AND IS PACKAGED IN PRESSURE SEALED TAPE,  
 REEL AND LEAD FREE.



© 2016 AFCI

mat'l. code		surface ISO 1302 ✓	tolerance ISO 406 ISO 1101	projection	product family CONAN®
ltr	ecn no	dr	date	tolerances unless otherwise specified	title
AL				angles linear	CONAN® CONNECTOR ASSEMBLY
				0°±x'	INCH/MM
				dr Eric Huang 10/11/15	scale 1:1
				engr Eric Huang 10/11/15	Amphenol FCI
				chr	dwg no sheet 7 of 7 size
				appd Tim Yao 10/11/15	91900 A3
sheet index	revision sheet				type Product Customer Drawing



Компания «ЭлектроПласт» предлагает заключение долгосрочных отношений при поставках импортных электронных компонентов на взаимовыгодных условиях!

Наши преимущества:

- Оперативные поставки широкого спектра электронных компонентов отечественного и импортного производства напрямую от производителей и с крупнейших мировых складов;
- Поставка более 17-ти миллионов наименований электронных компонентов;
- Поставка сложных, дефицитных, либо снятых с производства позиций;
- Оперативные сроки поставки под заказ (от 5 рабочих дней);
- Экспресс доставка в любую точку России;
- Техническая поддержка проекта, помощь в подборе аналогов, поставка прототипов;
- Система менеджмента качества сертифицирована по Международному стандарту ISO 9001;
- Лицензия ФСБ на осуществление работ с использованием сведений, составляющих государственную тайну;
- Поставка специализированных компонентов (Xilinx, Altera, Analog Devices, Intersil, Interpoint, Microsemi, Aeroflex, Peregrine, Syfer, Eurofarad, Texas Instrument, Miteq, Cobham, E2V, MA-COM, Hittite, Mini-Circuits, General Dynamics и др.);

Помимо этого, одним из направлений компании «ЭлектроПласт» является направление «Источники питания». Мы предлагаем Вам помощь Конструкторского отдела:

- Подбор оптимального решения, техническое обоснование при выборе компонента;
- Подбор аналогов;
- Консультации по применению компонента;
- Поставка образцов и прототипов;
- Техническая поддержка проекта;
- Защита от снятия компонента с производства.



#### Как с нами связаться

**Телефон:** 8 (812) 309 58 32 (многоканальный)

**Факс:** 8 (812) 320-02-42

**Электронная почта:** [org@eplast1.ru](mailto:org@eplast1.ru)

**Адрес:** 198099, г. Санкт-Петербург, ул. Калинина, дом 2, корпус 4, литера А.