

# Optically Coupled Isolator / High Speed Optically Coupled Isolator



## OPI150, OPI153, OPI155

### Features:

- 50 kV electrical isolation
- Choice of phototransistor or photodarlington output
- High speed 5 Mbit/sec (NRZ) OPI155 only
- Hermetically sealed LED and photosensor
- Base contact lead for conventional transistor biasing
- TX and TXV process available (see Hi-Rel section)



### Description:

Each **OPI150** and **OPI153** is an optically coupled isolator that contains an infrared emitting diode and a NPN silicon phototransistor (OPI150) or photodarlington (OPI153), each sealed in an individual hermetically sealed package. The diode and phototransistor or diode and photodarlington are then optically coupled by means of a light pipe and mounted in a high dielectric plastic housing. These devices are designed for applications that require very high isolation between input and output.

The **OPI155** is a high-speed optical coupled isolator that contains a high speed monolithic photo-IC comprised of a photodiode and a DC amplifier that drives an open collector output Schottky transistor. It is optically coupled by means of an internal light pipe. The LED and sensor are both in separate hermetically sealed packages that are then mounted in a high dielectric plastic housing. This device is designed for applications that require high speed *and* high voltage isolation between the input and output.

TX and TXV devices are available. Please contact your local representative or OPTEK for more information.

### Applications:

- Requiring high voltage isolation between input and output
- Electrical isolation in dirty environments
- Industrial equipment
- Medical equipment
- Office equipment

Ordering Information							
Part Number	LED Peak Wavelength	Sensor	Isolation Voltage (,000)	CTR Min / Max	I <sub>F</sub> (mA) Typ / Max	V <sub>CE</sub> (Volts) Max	Lead Length / Spacing
OPI150	890 nm	Transistor	50	10 / NA	16 / 50	30	0.40" / 3.16"
OPI153	890 nm or 935 nm	Darlington		25 / NA	30 / 50	15	
OPI155	850 nm	TIA -OC		80 / NA	10 / 50	18	

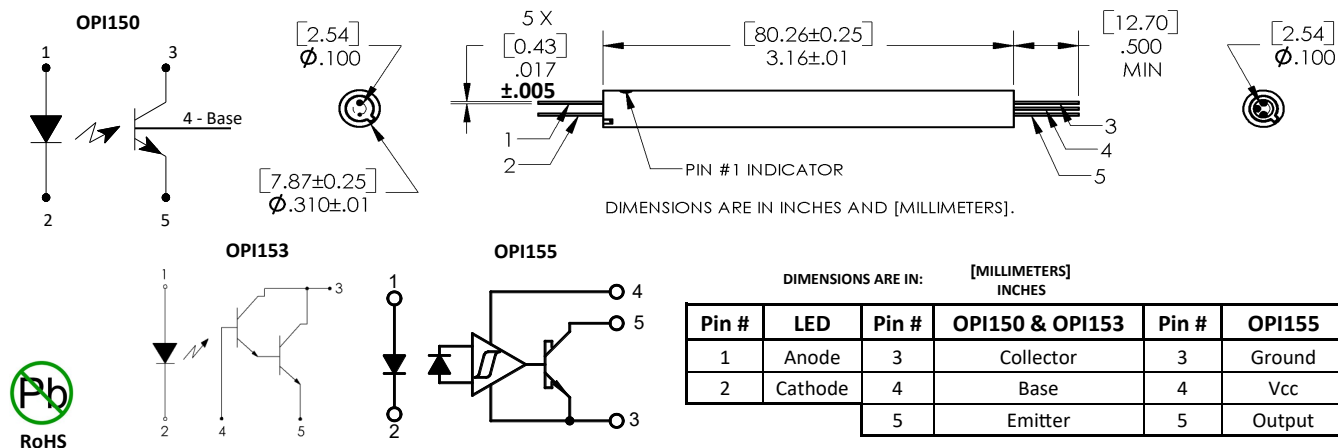

General Note  
TT Electronics reserves the right to make changes in product specification without notice or liability. All information is subject to TT Electronics' own data and is considered accurate at time of going to print.

TT Electronics | OPTEK Technology  
1645 Wallace Drive, Carrollton, TX 75006 | Ph: +1 972 323 2200  
www.ttelectronics.com | sensors@ttelectronics.com

# Optically Coupled Isolator / High Speed Optically Coupled Isolator



OPI150, OPI153, OPI155

## Electrical Specifications

<b>Absolute Maximum Ratings</b> ( $T_A = 25^\circ\text{C}$ unless otherwise noted)	
Operating Temperature Range	-40° C to +85° C
Storage Temperature Range	-40° C to +85° C
Input-to-Output Isolation Voltage <sup>(1)(2)</sup>	±50 kVDC
Lead Soldering Temperature [1/16 inch (1.6 mm) from the case for 5 seconds with soldering iron] <sup>(3)</sup>	260° C
<b>Input Diode</b>	
Continuous Forward Current	50 mA
Reverse Voltage	3 V
Power Dissipation <sup>(4)</sup>	200 mW
<b>Output Phototransistor or Photodarlington (OPI150, OPI153)</b>	
Collector-Base Voltage OPI150 OPI153	30 V 20 V
Collector-Emitter Voltage OPI150 OPI153	30 V 15 V
Emitter-Collector Voltage	5.0 V
Power Dissipation <sup>(5)</sup>	250 mW
<b>Output Photosensor (OPI155)</b>	
Supply Voltage	-0.5 to 7 V
Output Voltage	-0.5 to 18 V
Output Current	25 mA
Open-Collector Power Dissipation	40 mW
Power Dissipation <sup>(5)</sup>	250 mW

**Notes:**

- (1) For OPI150 and OPI153, measured with input leads and output leads shorted.
- (2) For OPI155, measured with input and output leads shorted and relative humidity of less than 50%.
- (3) RMA flux is recommended. Duration can be extended to 10 seconds maximum when flow soldering.
- (4) Derate linearly 3.33 mW/° C above 25° C.
- (5) Derate linearly 4.17 mW/° C above 25° C.

**General Note**

TT Electronics reserves the right to make changes in product specification without notice or liability. All information is subject to TT Electronics' own data and is considered accurate at time of going to print.

TT Electronics | OPTEK Technology  
1645 Wallace Drive, Carrollton, TX 75006 | Ph: +1 972 323 2200  
www.ttelectronics.com | sensors@ttelectronics.com

# Optically Coupled Isolator / High Speed Optically Coupled Isolator



OPI150, OPI153, OPI155

## Electrical Specifications

Electrical Characteristics (T <sub>A</sub> = 25° C unless otherwise noted)						
SYMBOL	PARAMETER	MIN	TYP	MAX	UNITS	TEST CONDITIONS
<b>Input Diode</b> (For OPI150 & OPI153, see OP236 for additional information - for reference only. For OPI155, see OP235W for additional information - for reference only.)						
V <sub>F</sub>	Forward Voltage OPI150, OPI153 OPI155	- -	1.3 1.2	1.6 1.6	V	I <sub>F</sub> = 50 mA I <sub>F</sub> = 10 mA
I <sub>R</sub>	Reverse Current	-	0.1	100	μA	V <sub>R</sub> = 3 V
<b>Output Phototransistor or Photodarlington</b> (For OPI150, see OP805SL for additional information, for OPI153, see OP830SL for additional information- for reference only.)						
V <sub>(BR)CEO</sub>	Collector-Emitter Breakdown Voltage OPI150 OPI153	30 15	- -	- -	V	I <sub>C</sub> = 1 mA
V <sub>(BR)ECO</sub>	Emitter-Collector Breakdown Voltage OPI150, OPI153	5	-	-	V	I <sub>F</sub> = 100 μA
V <sub>(BR)CBO</sub>	Collector-Base Breakdown Voltage OPI150 OPI153	30 20	- -	- -	V	I <sub>C</sub> = 100 μA
I <sub>CEO</sub>	Collector-Emitter Dark Current OPI150 OPI153	- -	- -	100 500	nA	V <sub>CE</sub> = 10 V
I <sub>CB0</sub>	Collector-Base Dark Current OPI150	-	-	-	nA	V <sub>CB</sub> = 10 V
<b>Coupled (OPI150, OPI153)</b>						
I <sub>C</sub> /I <sub>F</sub>	DC Current Transfer Ratio OPI150 OPI153	10 25	- -	- -	%	I <sub>F</sub> = 10 mA, V <sub>CE</sub> = 5 V I <sub>F</sub> = 20 mA, V <sub>CE</sub> = 5 V
I <sub>CB(ON)</sub>	I <sub>b0</sub> State Photodiode Current OPI150	10	-	-	μA	I <sub>F</sub> = 20 mA, V <sub>CB</sub> = 5 V
V <sub>CE(SAT)</sub>	Saturation Voltage OPI150 OPI153	- -	- -	0.5 1.2	V	I <sub>F</sub> = 16 mA, I <sub>C</sub> = 1 mA I <sub>F</sub> = 30 mA, I <sub>C</sub> = 2 mA

**General Note**

TT Electronics reserves the right to make changes in product specification without notice or liability. All information is subject to TT Electronics' own data and is considered accurate at time of going to print.

TT Electronics | OPTEK Technology  
1645 Wallace Drive, Carrollton, TX 75006 | Ph: +1 972 323 2200  
www.ttelectronics.com | sensors@ttelectronics.com

# Optically Coupled Isolator / High Speed Optically Coupled Isolator



OPI150, OPI153, OPI155

## Electrical Specifications

Electrical Characteristics (T <sub>A</sub> = 25° C unless otherwise noted)						
SYMBOL	PARAMETER	MIN	TYP	MAX	UNITS	TEST CONDITIONS
<b>Output Photosensor (OPI155)</b>						
I <sub>OH</sub>	High Level Output Current OPI155	-	-	250	μA	V <sub>O</sub> = 18 V, I <sub>F</sub> = 0, V <sub>CC</sub> = Open
I <sub>CCH</sub>	High Level Supply Current OPI155	-	-	6.5	mA	V <sub>CC</sub> = 5.25 V, I <sub>F</sub> = 0, V <sub>O</sub> = Open
I <sub>CCL</sub>	Low Level Supply Current OPI155	-	-	10	mA	V <sub>CC</sub> = 5.25 V, I <sub>F</sub> = 10 mA, V <sub>O</sub> = 0
V <sub>OL</sub>	Low Level Output Voltage OPI155	-	-	0.5	V	V <sub>CC</sub> = 5.25 V, I <sub>F</sub> = 10 mA, I <sub>O</sub> = 8 mA
<b>Switching Characteristics (OPI155)</b>						
T <sub>PHL</sub>	Propagation Delay, High to Low	-	120	150	ns	V <sub>CC</sub> = 5 V, I <sub>F</sub> = 10 mA, R <sub>L</sub> = 360 Ω
T <sub>PLH</sub>	Propagation Delay, Low to High	-	70	100		

### General Note

TT Electronics reserves the right to make changes in product specification without notice or liability. All information is subject to TT Electronics' own data and is considered accurate at time of going to print.

TT Electronics | OPTEK Technology  
1645 Wallace Drive, Carrollton, TX 75006 | Ph: +1 972 323 2200  
www.ttelectronics.com | sensors@ttelectronics.com



Компания «ЭлектроПласт» предлагает заключение долгосрочных отношений при поставках импортных электронных компонентов на взаимовыгодных условиях!

Наши преимущества:

- Оперативные поставки широкого спектра электронных компонентов отечественного и импортного производства напрямую от производителей и с крупнейших мировых складов;
- Поставка более 17-ти миллионов наименований электронных компонентов;
- Поставка сложных, дефицитных, либо снятых с производства позиций;
- Оперативные сроки поставки под заказ (от 5 рабочих дней);
- Экспресс доставка в любую точку России;
- Техническая поддержка проекта, помощь в подборе аналогов, поставка прототипов;
- Система менеджмента качества сертифицирована по Международному стандарту ISO 9001;
- Лицензия ФСБ на осуществление работ с использованием сведений, составляющих государственную тайну;
- Поставка специализированных компонентов (Xilinx, Altera, Analog Devices, Intersil, Interpoint, Microsemi, Aeroflex, Peregrine, Syfer, Eurofarad, Texas Instrument, Miteq, Cobham, E2V, MA-COM, Hittite, Mini-Circuits, General Dynamics и др.);

Помимо этого, одним из направлений компании «ЭлектроПласт» является направление «Источники питания». Мы предлагаем Вам помощь Конструкторского отдела:

- Подбор оптимального решения, техническое обоснование при выборе компонента;
- Подбор аналогов;
- Консультации по применению компонента;
- Поставка образцов и прототипов;
- Техническая поддержка проекта;
- Защита от снятия компонента с производства.



#### Как с нами связаться

**Телефон:** 8 (812) 309 58 32 (многоканальный)

**Факс:** 8 (812) 320-02-42

**Электронная почта:** [org@eplast1.ru](mailto:org@eplast1.ru)

**Адрес:** 198099, г. Санкт-Петербург, ул. Калинина, дом 2, корпус 4, литера А.