

# AT-233-PIN

Digital Attenuator  
30.0 dB, 4-Bit, TTL Driver, DC-2.0 GHz

Rev. V5

## Features

- Attenuation: 2 dB Steps to 30 dB
- Temperature Stability:  $\pm 0.18$  dB from  $-55^{\circ}\text{C}$  to  $+85^{\circ}\text{C}$  Typical
- Low DC Power Consumption
- Hermetic Surface Mount Package
- Integral TTL Driver
- 50 Ohm Nominal Impedance
- Lead-Free CR-12 Package
- $260^{\circ}\text{C}$  Reflow Compatible
- RoHS\* Compliant

## Description

M/A-COM's AT-233-PIN is a GaAs FET 4-Bit digital attenuator with a 2 dB minimum step size and 30 dB total attenuation. This attenuator and integral TTL driver is in a hermetically sealed ceramic 16-lead surface mount package. The AT-233-PIN is ideally suited for use where accuracy, fast switching, very low power consumption and low intermodulation products are required. Typical applications include dynamic range setting in precision receiver circuits and other gain/leveling control circuits. Environmental screening is available. Contact the factory for information.

## Ordering Information

Part Number	Package
AT-233-PIN	Bulk Packaging
MAAD-007228-0001TR	1000 piece reel
MAAD-007228-0001TB	Sample Test Board

Note: Reference Application Note M513 for reel size information.

## Functional Schematic

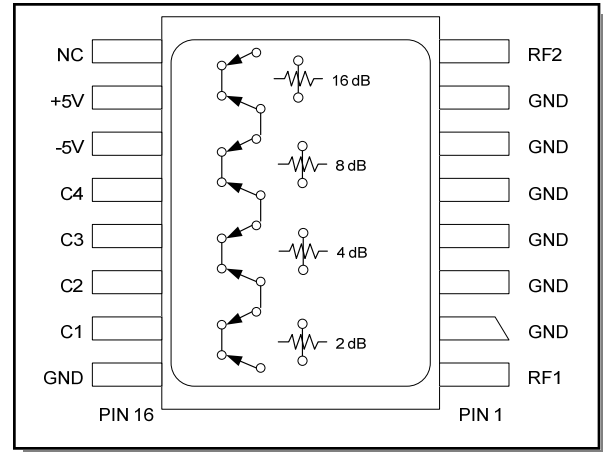

## Pin Configuration

Pin No.	Function	Pin No.	Function
1	RF1	9	NC
2	GND	10	+5V
3	GND	11	-5V
4	GND	12	C4
5	GND	13	C3
6	GND	14	C2
7	GND	15	C1
8	RF2	16	GND

The metal bottom of the case must be connected to RF and DC ground.

\* Restrictions on Hazardous Substances, European Union Directive 2002/95/EC.

## Electrical Specifications: $T_A = 25^\circ\text{C}^1$

Parameter	Test Conditions	Frequency	Units	Min	Typ	Max
Reference Insertion Loss	—	DC - 0.5 GHz DC - 1.0 GHz DC - 2.0 GHz	dB dB dB	— — —	— — —	2.3 2.65 2.8
Attenuation Accuracy <sup>2</sup>	Any Single Bit  Any Combination of Bits	DC - 1.0 GHz DC - 2.0 GHz  DC - 1.0 GHz DC - 2.0 GHz		$\pm (0.2 + 3\% \text{ of attenuation setting in dB})$ dB $\pm (0.2 + 3\% \text{ of attenuation setting in dB})$ dB or $\pm 0.45$ dB, whichever is greater $\pm (0.20 + 3\% \text{ of attenuation setting in dB})$ dB $\pm (0.25 + 4\% \text{ of attenuation setting in dB})$ dB or $\pm 0.45$ dB, whichever is greater		
VSWR	—	DC - 2.0 GHz	Ratio	—	—	1.7:1
Trise, Tfall	10% to 90%	—	ns	—	10	—
Ton, Toff	50% Control to 90/10% RF	—	ns	—	30	—
Transients	In-Band (peak-peak)	—	mV	—	35	—
1 dB Compression <sup>3</sup>	Input Power	0.05 GHz 0.5 - 2.0 GHz	dBm dBm	— —	+20 +28	— —
Input IP3 <sup>3</sup>	For two tone input power Up to +5 dBm	0.05 GHz 0.5 - 2.0 GHz	dBm dBm	— —	+40 +50	— —
Input IP2 <sup>3</sup>	For two-tone input power Up to +5 dBm	0.05 GHz 0.5 - 2.0 GHz	dBm dBm	— —	+45 +68	— —
V <sub>CC</sub>	—	—	V	4.5	5.0	5.5
V <sub>EE</sub>	—	—	V	-8.0	—	-5.0
I <sub>CC</sub>	V <sub>CC</sub> = 4.5 to 5.5 V V <sub>ctl</sub> = 0 to 0.8V, or V <sub>CC</sub> – 2.1V to V <sub>CC</sub>	—	mA	—	—	4.0
I <sub>EE</sub>	V <sub>EE</sub> = -5.0 to -8.0V	—	mA	—	—	1.0
V <sub>ctl</sub>	Logic 0 (TTL) Logic 1 (TTL)	— —	V V	0.0 2.0	— —	0.8 5.0
Input Leakage Current (Low) Input Leakage Current (High)	0 to 0.8V 2.0 to 5.0V	— —	$\mu\text{A}$ $\mu\text{A}$	— —	— —	1.0 1.0

1. All specifications apply when operated with bias voltages of +5V for V<sub>CC</sub> and -5.0V to -8.0V for V<sub>EE</sub>, and 50 Ohm impedance at all ports unless otherwise specified.
2. This attenuator is guaranteed monotonic.
3. V<sub>EE</sub> = -5V for the typical numbers given.

## Absolute Maximum Ratings <sup>4,5</sup>

Parameter	Absolute Maximum
Max Input Power 0.5 GHz 0.5 - 2.0 GHz	+27 dBm +34 dBm
$V_{CC}$	$-0.5V \leq V_{CC} \leq +7.0V$
$V_{EE}$	$-8.5V \leq V_{EE} \leq +0.5V$
$V_{CC} - V_{EE}$	$-0.5V \leq V_{CC} - V_{EE} \leq 14.5V$
$V_{in}^6$	$-0.5V \leq V_{in} \leq V_{CC} + 0.5V$
Operating Temperature	$-55^{\circ}C$ to $+125^{\circ}C$
Storage Temperature	$-65^{\circ}C$ to $+150^{\circ}C$

- Exceeding any one or combination of these limits may cause permanent damage to this device.
- M/A-COM does not recommend sustained operation near these survivability limits.
- Standard CMOS TTL interface, latch-up will occur if logic signal is applied prior to power supply.

## Handling Procedures

Please observe the following precautions to avoid damage:

## Static Sensitivity

Gallium Arsenide Integrated Circuits are sensitive to electrostatic discharge (ESD) and can be damaged by static electricity. Proper ESD control techniques should be used when handling these devices.

## Typical Performance Curves

### Ref. Insertion Loss vs. Frequency

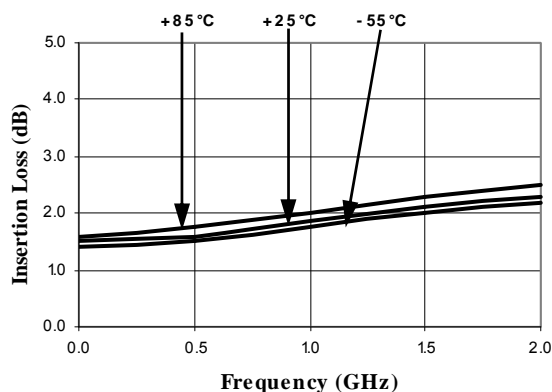

## Recommended PCB Configuration

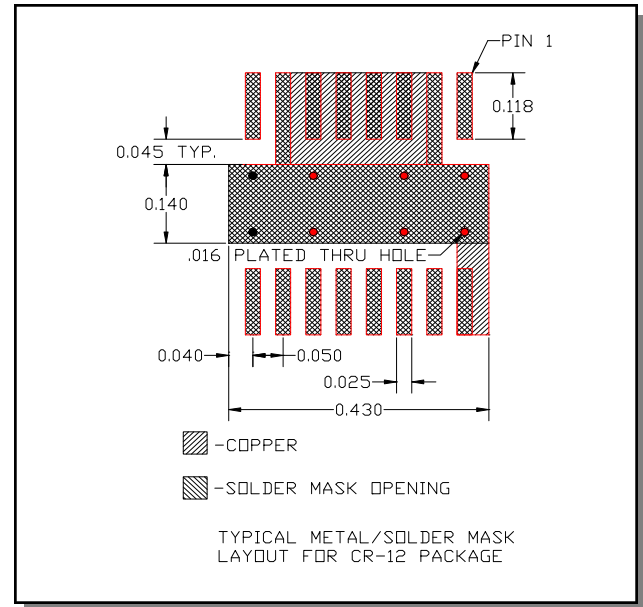

## Truth Table (Digital Attenuator)

Control Inputs				
C4	C3	C2	C1	Attenuation
0	0	0	0	Reference
0	0	0	1	2 dB
0	0	1	0	4 dB
0	1	0	0	8 dB
1	0	0	0	16 dB
1	1	1	1	30 dB

0 = TTL Low; 1 = TTL High

### VSWR vs. Frequency

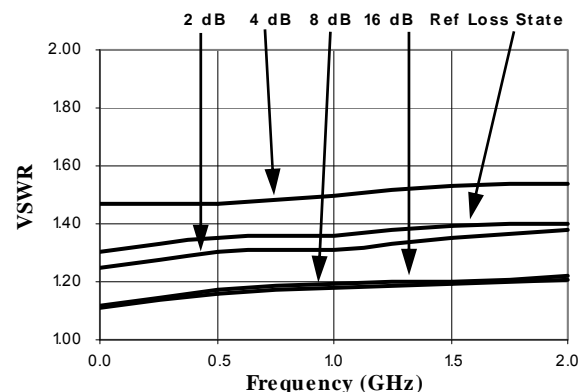

# AT-233-PIN

Digital Attenuator  
30.0 dB, 4-Bit, TTL Driver, DC-2.0 GHz

Rev. V5

## Typical Performance Curves

Attenuation Accuracy vs. Frequency

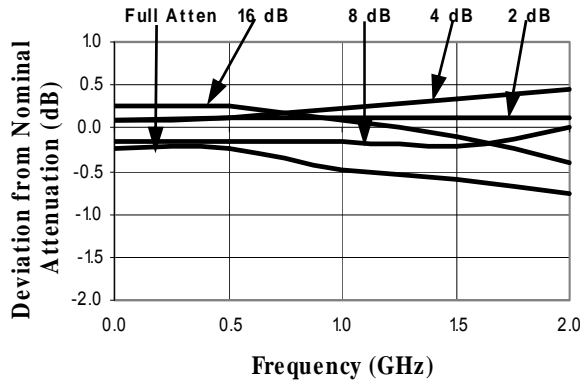

## Lead-Free CR-12 Ceramic Package<sup>†</sup>

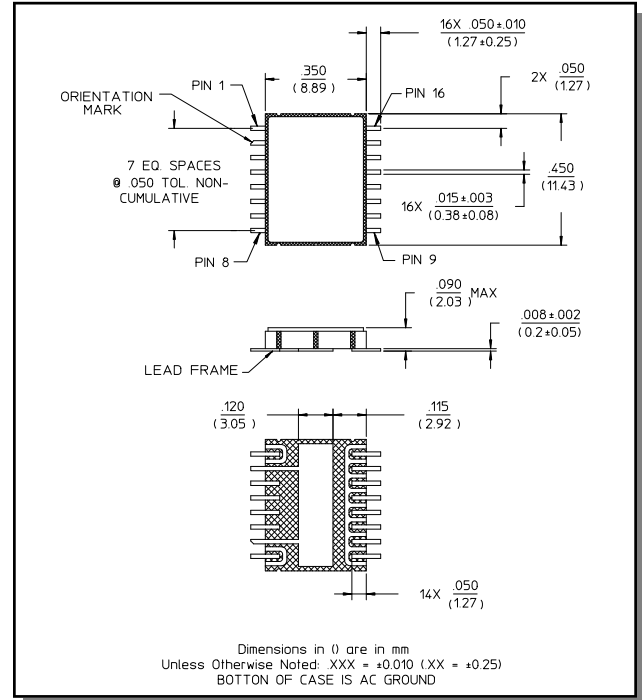

<sup>†</sup> Reference Application Note M538 for lead-free solder reflow recommendations.



Компания «ЭлектроПласт» предлагает заключение долгосрочных отношений при поставках импортных электронных компонентов на взаимовыгодных условиях!

Наши преимущества:

- Оперативные поставки широкого спектра электронных компонентов отечественного и импортного производства напрямую от производителей и с крупнейших мировых складов;
- Поставка более 17-ти миллионов наименований электронных компонентов;
- Поставка сложных, дефицитных, либо снятых с производства позиций;
- Оперативные сроки поставки под заказ (от 5 рабочих дней);
- Экспресс доставка в любую точку России;
- Техническая поддержка проекта, помощь в подборе аналогов, поставка прототипов;
- Система менеджмента качества сертифицирована по Международному стандарту ISO 9001;
- Лицензия ФСБ на осуществление работ с использованием сведений, составляющих государственную тайну;
- Поставка специализированных компонентов (Xilinx, Altera, Analog Devices, Intersil, Interpoint, Microsemi, Aeroflex, Peregrine, Syfer, Eurofarad, Texas Instrument, Miteq, Cobham, E2V, MA-COM, Hittite, Mini-Circuits, General Dynamics и др.);

Помимо этого, одним из направлений компании «ЭлектроПласт» является направление «Источники питания». Мы предлагаем Вам помощь Конструкторского отдела:

- Подбор оптимального решения, техническое обоснование при выборе компонента;
- Подбор аналогов;
- Консультации по применению компонента;
- Поставка образцов и прототипов;
- Техническая поддержка проекта;
- Защита от снятия компонента с производства.



#### Как с нами связаться

**Телефон:** 8 (812) 309 58 32 (многоканальный)

**Факс:** 8 (812) 320-02-42

**Электронная почта:** [org@eplast1.ru](mailto:org@eplast1.ru)

**Адрес:** 198099, г. Санкт-Петербург, ул. Калинина, дом 2, корпус 4, литера А.