



## 720 GFX-i Series Sealed and Rugged Keypads

These tough, water resistant keypads feature moving, tactile keys with a responsive 'over-centre' action. Keytop graphics can be easily customized by the use of legend tiles under 'snap-on' transparent keycaps. Once snapped into place the tamper resistant keycaps encapsulate and protect the keytop graphics. These keypads have integral white light LED illumination for use in dark or partially lit locations.



The keypad can be installed on the surface or under the panel.

Fit the supplied silicone seal into the seal groove on the keypad. Use the groove on top for underpanel, and on back for surface fix. The wide part of the seal goes into the groove – see picture below of the seal fitted to the back of the keypad.

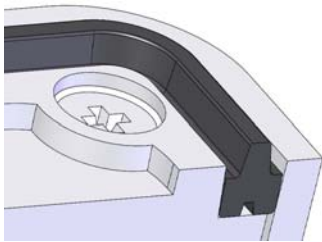

To customise the layout place a colour tile and a legend tile onto the key base, and clip the keycap over the top.

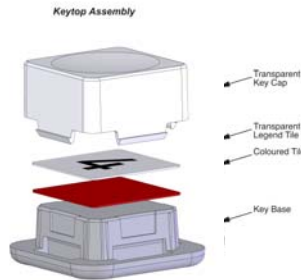

### Connection Details

#### Connection Details for 4 Key Keypad

CONTACT CONNECTIONS  
 ● ● ● ● ● ●  
 7 6 5 4 3 2 1  
 (As viewed from rear of keypad)

KEY LOCATION  
 (As viewed from front of keypad)

CONTACT MATRIX	
CONNEC. PIN	ROW/COLUMN
1	Cathode
2	Common
3	D
4	C
5	B
6	A
7	Anode

#### Connection Details for 12 Key Keypad

CONTACT CONNECTIONS  
 ● ● ● ● ● ● ● ● ● ● ● ●  
 10 9 8 7 6 5 4 3 2 1  
 (As viewed from rear of keypad)

KEY LOCATION  
 (As viewed from front of keypad)

CONTACT MATRIX	
CONNEC. PIN	ROW/COLUMN
1	Cathode
2	A
3	B
4	1
5	2
6	3
7	-
8	D
9	C
10	Anode

#### Connection Details for 16 Key Keypad

CONTACT CONNECTIONS  
 ● ● ● ● ● ● ● ● ● ● ● ● ● ● ● ●  
 10 9 8 7 6 5 4 3 2 1  
 (As viewed from rear of keypad)

KEY LOCATION  
 (As viewed from front of keypad)

CONTACT MATRIX	
CONNEC. PIN	ROW/COLUMN
1	Cathode
2	A
3	B
4	1
5	2
6	3
7	4
8	D
9	C
10	Anode

White Colour Tiles and Set A Legends are included; Set A Legends comprises :-

**1 2 3 4 5 6 7 8 9 0 + = x ÷ \* # . ← ↑ → ↓ AC I/O ENT CE/E**

Additional Legends ( Tile sets B,C,D,E,F, ) & Colours (White, Grey, Red, Green, Blue, Yellow) are available

### Electrical

Contact Bounce **5 ms (max)**  
 Contact Resistance **100 ohms (max)**  
 Insulation Resistance **50 Mohms (min)**  
 Breakdown Voltage **500 V AC (max 60 secs.)**  
 Switch Rating **24V DC 50mA (max)**  
 Connection **X-Y Matrix**  
 Illumination ( Pin 1 is 0 V) **5 V DC ± 10 % , 13mA per key**

### Mechanical

Operational Life **2 million cycles (min) per key**  
 Keytop Travel **1.4mm nominal**  
 Actuation Force **150 grams nominal**  
 Connector **0.1"pitch, gold plated square pin**  
 Mating Connector **Molex 2695 Series or equivalent**

### Performance

Operational Temp **-20°C to 60°C**  
 Impact Rating **5 J**  
 Vibration/Shock **ETSI 300 019 5M3**  
 Water / Dust sealed **IP65 (when fixed to suitable panel )**

### Part Numbers

7207-041W20 **720GFXi SERIES 4 KEY**  
 7207-121W20 **720GFXi SERIES 12 KEY**  
 7207-161W20 **720GFXi SERIES 16 KEY**

### Accessories

4200-00 **RS232 Encoder Interface Module**  
 4500-10 **450 USB Encoder Interface Module with Buzzer and Illumination Control**  
 Colour & Legend Tiles & Replacement Seals go to [www.storm-interface.com](http://www.storm-interface.com)

### Dimensions

Overall sizes **See following page**  
 Panel Cutout DXF **Download .dxf and .stp files from**  
 Surface Model STEP **www.storm-interface.com**



Install the keypad onto the surface of a panel as follows :-

- Fit the seal to the rear of the keypad
- Place the keypad onto the panel and fit the self locking nuts to the studs on the back
- Recommended tightening torque 50Ncm

Side View : 4, 12, 16

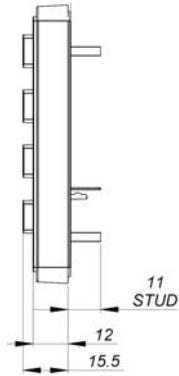

Front and Back View : 4 way

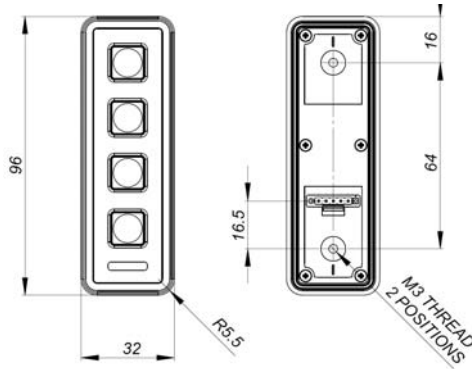

Panel Cutout : 4 way

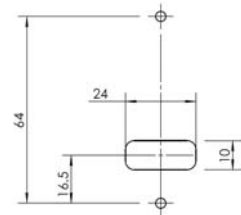

Front and Back View, 12 way

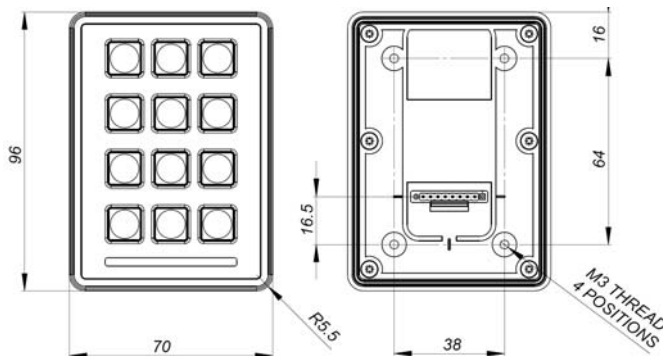

Panel Cutout : 12 way

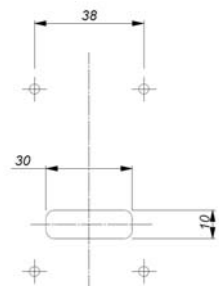

Front and Back View, 16 way

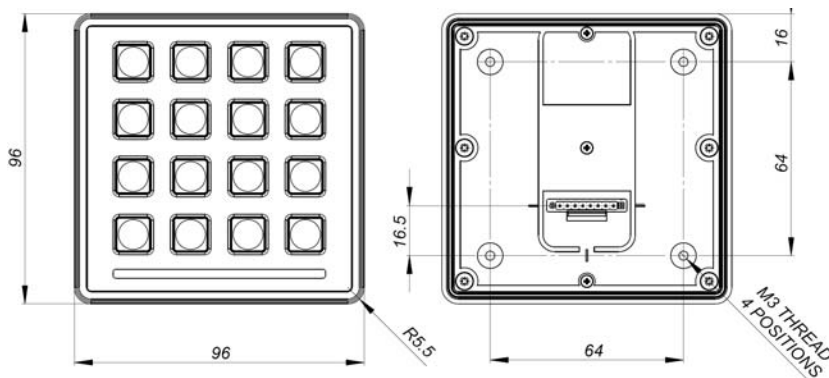

Panel Cutout : 16 way

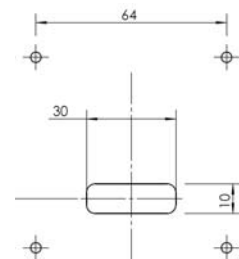

All panel dims in mm.  
Corner Rads all M3



Компания «ЭлектроПласт» предлагает заключение долгосрочных отношений при поставках импортных электронных компонентов на взаимовыгодных условиях!

Наши преимущества:

- Оперативные поставки широкого спектра электронных компонентов отечественного и импортного производства напрямую от производителей и с крупнейших мировых складов;
- Поставка более 17-ти миллионов наименований электронных компонентов;
- Поставка сложных, дефицитных, либо снятых с производства позиций;
- Оперативные сроки поставки под заказ (от 5 рабочих дней);
- Экспресс доставка в любую точку России;
- Техническая поддержка проекта, помощь в подборе аналогов, поставка прототипов;
- Система менеджмента качества сертифицирована по Международному стандарту ISO 9001;
- Лицензия ФСБ на осуществление работ с использованием сведений, составляющих государственную тайну;
- Поставка специализированных компонентов (Xilinx, Altera, Analog Devices, Intersil, Interpoint, Microsemi, Aeroflex, Peregrine, Syfer, Eurofarad, Texas Instrument, Miteq, Cobham, E2V, MA-COM, Hittite, Mini-Circuits, General Dynamics и др.);

Помимо этого, одним из направлений компании «ЭлектроПласт» является направление «Источники питания». Мы предлагаем Вам помощь Конструкторского отдела:

- Подбор оптимального решения, техническое обоснование при выборе компонента;
- Подбор аналогов;
- Консультации по применению компонента;
- Поставка образцов и прототипов;
- Техническая поддержка проекта;
- Защита от снятия компонента с производства.



#### Как с нами связаться

**Телефон:** 8 (812) 309 58 32 (многоканальный)

**Факс:** 8 (812) 320-02-42

**Электронная почта:** [org@eplast1.ru](mailto:org@eplast1.ru)

**Адрес:** 198099, г. Санкт-Петербург, ул. Калинина, дом 2, корпус 4, литера А.